

State of California
AIR RESOURCES BOARD

Executive Order G-70-48-AA

Recertification of the Mobil Oil Balance
Phase II Vapor Recovery System

WHEREAS, the Air Resources Board (the "Board") has established, pursuant to Sections 39600, 39601, and 41954 of the Health and Safety Code, certification procedures for systems designed for the control of gasoline vapor emissions during motor vehicle fueling operations ("Phase II vapor recovery systems") in its "Certification Procedures for Gasoline Vapor Recovery Systems at Service Stations" as last amended December 4, 1981 (the "Certification Procedures"), incorporated by reference in Section 94001 of Title 17, California Administrative Code;

WHEREAS, the Board has established, pursuant to Sections 39600, 39601, and 41954 of the Health and Safety Code, test procedures for determining compliance of Phase II vapor recovery systems with emission standards in its "Test Procedures for Determining the Efficiency of Gasoline Vapor Recovery Systems at Services Stations" as last amended September 1, 1982 (the "Test Procedures"), incorporated by reference in Section 94000 of Title 17, California Administrative Code;

WHEREAS, Section V.F. of the Certification Procedures states that whenever additional performance standards or other requirements for certification of Phase II vapor recovery systems are adopted, any system which is certified as of the effective date of the additional standards or requirements shall remain certified for a period of six months from such date, or until the Executive Officer has determined whether the system conforms to the additional standards or requirements, whichever occurs first;

WHEREAS, the Certification Procedures, as amended on December 4, 1981, contain new performance standards for spillage and spitback losses of gasoline during vehicle fueling in Section IV-D;

WHEREAS, Mobil Oil Company has requested that the maximum allowable gasoline dispensing rate for Phase II vapor recovery systems be increased to permit faster fuelings;

WHEREAS, the Mobil Oil balance Phase II vapor recovery system has been evaluated pursuant to the Certification Procedures and Test Procedures;

WHEREAS, Section VIII.A. of the Certification Procedures provides that the Executive Officer shall issue an order of certification if he or she determines that a vapor recovery system conforms to all of the requirements set forth in paragraphs I through VII;

WHEREAS, I find that an increase in the maximum allowable gasoline dispensing rate will not affect vapor recovery system efficiency, may improve customer satisfaction by permitting faster vehicle fueling, and may improve the reliability of vapor recovery nozzle shut-off mechanisms, thus reducing the potential for gasoline recirculation;

WHEREAS, I find that the use of high-retractor or high-hang hose configurations and the use of multiplane swivels on the nozzle end of the liquid and vapor hoses for high-retractor twin hose configurations are necessary for the Mobil Oil Balance Phase II vapor recovery systems to meet the new performance standards for gasoline spillage and spitback;

WHEREAS, I find that it is necessary that the certification of the Mobil Oil balance Phase II vapor recovery system be modified to require the use of high-retractor or high-hang hose configurations with appropriate swivel arrangements; and

WHEREAS, I find that the Mobil Oil balance Phase II vapor recovery system modified as set forth in this Executive Order conforms with all the requirements set forth in paragraphs I through VII of the Certification Procedures and is at least 95 percent effective for attendant and/or self-serve use at gasoline service stations when used in conjunction with Phase I vapor recovery systems that have been certified by the Board.

NOW, THEREFORE, IT IS HEREBY ORDERED that the certification, Executive Order G-70-48-A, issued on April 7, 1980 for the Mobil Oil balance Phase II vapor recovery system is hereby modified to:

1. Increase the maximum allowable gasoline dispensing rate to ten gallons per minute (gpm) for twin-hose configurations. For coaxial hose configurations, the maximum allowable dispensing rate shall be eight gallons per minute;
2. Require the use of high-retractor or high-hang hose configurations including swivel arrangements, as specified in the latest revision of Executive Order G-70-52. Pursuant to Health and Safety Code Sections 41954 and 41956.1, this provision is applicable immediately for new system installations and is applicable July 26, 1986 for existing system installations; and
3. Require float check valves (or alternate equipment, design, or operating procedures acceptable to the Air Resources Board) for all manifold piping on new installations to prevent contamination of unleaded gasoline with leaded gasoline, via vapor recovery piping, during storage tank loading or overfill.

IT IS FURTHER ORDERED that this system is certified to be at least 95 percent effective in the self-serve and/or attendant use at gasoline service stations when used with a Board certified Phase I vapor recovery system. A typical

pipng arrangement for this system is described in Exhibit I. All certified components are listed in the latest revision of Executive Order G-70-52.

IT IS FURTHER ORDERED that compliance with the applicable certification requirements and rules and regulations of the Division of Measurement Standards, the State Fire Marshal's Office, and the Division of Occupational Safety and Health of the Department of Industrial Relations is made a condition of this certification.

IT IS FURTHER ORDERED that the system certified hereby shall perform in actual use with the same effectiveness as the certification test system. Compliance with this performance criterion shall be a condition of this certification, and failure to meet this criterion shall constitute grounds for revocation, suspension or modification of this certification.

IT IS FURTHER ORDERED that any alteration of the equipment, parts, design, or operation of the configurations certified hereby, is prohibited, and deemed inconsistent with this certification, unless such alteration has been approved by the undersigned or the Executive Officer's designee.

IT IS FURTHER ORDERED that all nozzles approved for use with this system shall be 100 percent performance checked at the factory including checks of proper functioning of all automatic shut-off mechanisms.

IT IS FURTHER ORDERED that the certified phase II vapor recovery system shall, at a minimum, be operated in accordance with the manufacturer's recommended maintenance intervals and shall use the manufacturer's recommended operation, installation, and maintenance procedures, if available.

IT IS FURTHER ORDERED that the certified Phase II vapor recovery system shall be performance tested during installation for ability to dispense gasoline and collect vapors without difficulty in the presence of the station manager or other responsible individual. The station manager, owner, or operator shall be provided with instructions on the proper use, maintenance, and repair of the system, and where system components can be readily obtained. A copy of the system warranty shall also be made available to the station manager, owner, or operator.

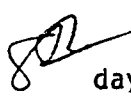
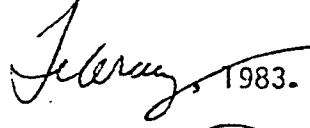
Executed at Sacramento, California this  day of  1983.

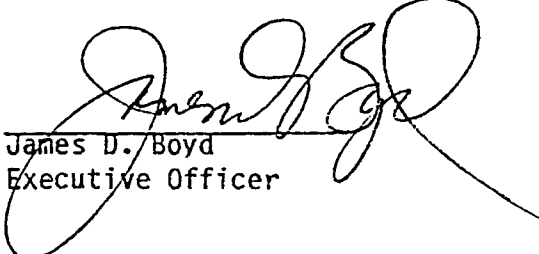
James D. Boyd
Executive Officer

MOBIL OIL CORP - BALANCE PHASE II
VAPOR RECOVERY SYSTEM

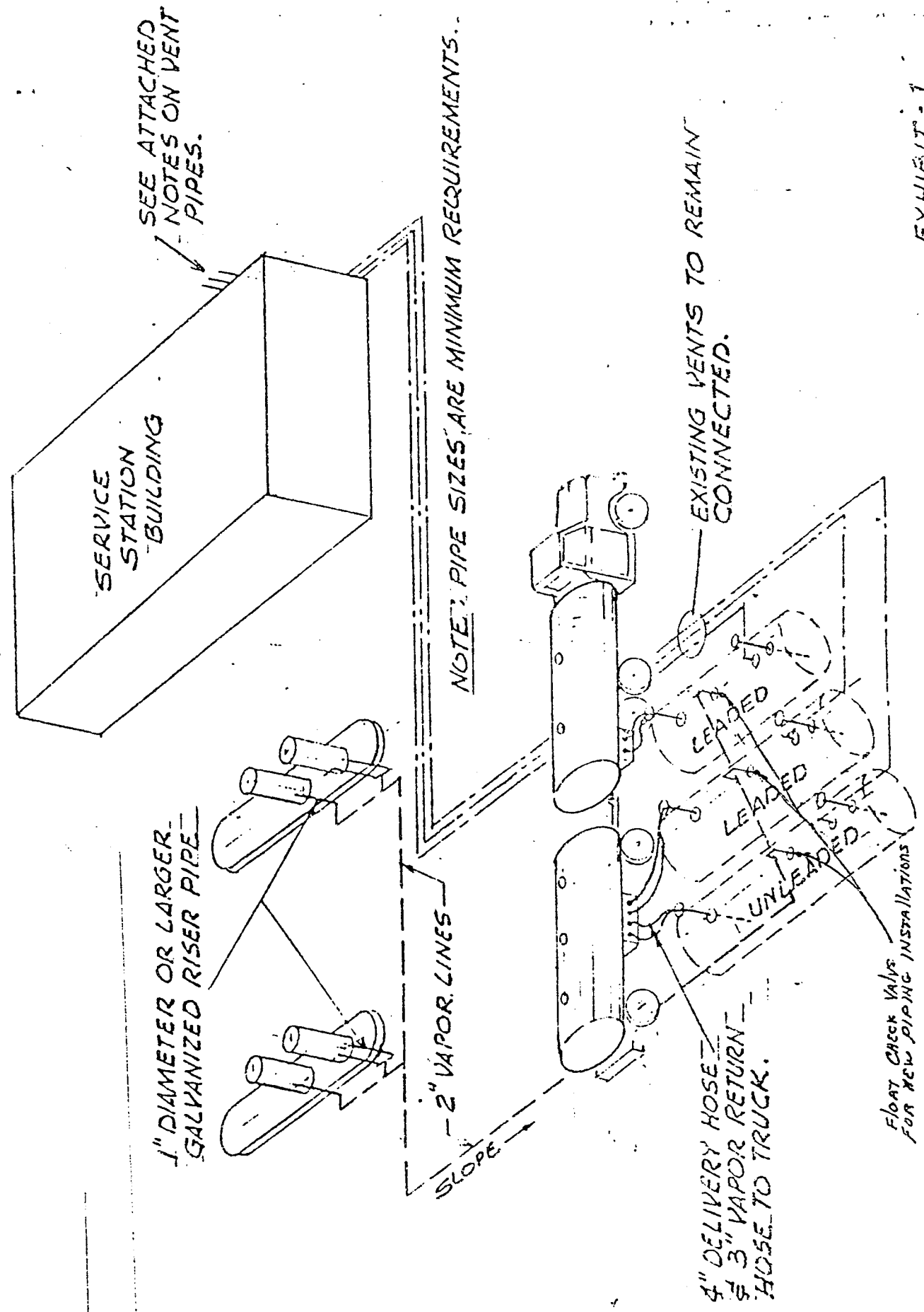

SEE ATTACHED
NOTES ON VENT
PIPES.

SERVICE
STATION
BUILDING

1" DIAMETER OR LARGER
GALVANIZED RISER PIPE

2" VAPOR LINES

SLOPE

NOTE: PIPE SIZES ARE MINIMUM REQUIREMENTS.

EXISTING VENTS TO REMAIN
CONNECTED.

4" DELIVERY HOSE
3" VAPOR RETURN
HOSE TO TRUCK.

FLOAT CHECK VALVE
FOR NEW PIPING INSTALLATIONS

EXHIBIT - I

EXECUTIVE ORDER G-70-48-AA
NOTES TO ACCOMPANY EXHIBIT 1

1. For non-retail outlets which fuel special vehicles, the installation of vapor recovery hoses longer than specified in the latest version of Executive Order G-70-52 are allowed if the following conditions are met:
 - a. The non-retail outlet fuels special vehicles such as large trucks, large skip loaders, off-the-road equipment, etc. where reaching the fill pipe requires longer hoses.
 - b. The vapor return hoses are arranged to be self-draining or provisions are made to drain the hoses after each refueling or the system incorporates an approved liquid blockage detection system arranged to cease dispensing when a blockage occurs.
 - c. The Executive Officer of the Air Resources Board or his/her designee has approved the plans for compliance with condition b.
2. The maximum allowable pressure drop through a system including nozzle, vapor hose, swivels, and underground piping is:
 - a. 0.15 inch water at a flow of 20 CFH;
 - b. 0.45 inch water at a flow of 60 CFH;
 - c. 0.95 inch water at a flow of 100 CFH.

A pressure drop test must be conducted with the drybreak to the underground tank open.

3. The vent pipes and vent manifold shall be adequately supported throughout their length and when they are supporting weights in addition to their own, additional supports may be required, such as anchoring to a building or other structure.
4. All vapor return and vent piping shall be equipped with swing joints at the base of the riser to each dispensing unit, at each tank connection, and at the base of the vent riser where it fastens to a building or other structure. When a swing joint is used in a riser containing a shear section, the riser must be rigidly supported.
5. On new installations, float check valves (or alternate equipment, design, or operating procedures acceptable to the Air Resources Board) are required for all underground manifolded piping to prevent contamination of unleaded gasoline with leaded gasoline, via vapor recovery piping, during underground storage tank loading or overfill.