

California Environmental Protection Agency

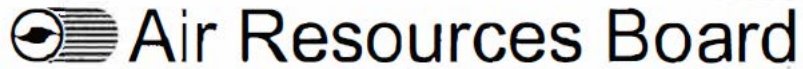

Northern Laboratory Branch
Monitoring and Laboratory Division

MLD SOP SAS12

**Standard Operating Procedure for the Determination of
Aromatic Compound Content in Multi-purpose Solvent and
Paint Thinner Products**

January 2012

Approved by:

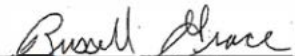

Russell Grace, Manager
Special Analysis Section

1-20-12
Date



Cindy Castronovo, Chief
Northern Laboratory Branch

1/23/12
Date

DISCLAIMER: Mention of any trade name or commercial product in Method 310 and associated Standard Operating Procedures does not constitute endorsement or recommendation of this product by the Air Resources Board. Specific brand names and instrument descriptions listed in the Standard Operating Procedures are equipment used by ARB laboratory. Any functionally equivalent instrumentation can be used.

1 INTRODUCTION

This Standard Operating Procedure (SOP) describes the analysis of the aromatic compound content in multi-purpose solvent and paint thinners. "Aromatic Compound," "Multi-purpose Solvent," and "Paint Thinner" are defined in section 94508(a) of the California Consumer Products regulations, Title 17, California Code of Regulations. In accordance with section 94509(p)(1), no person shall sell, supply, offer for sale, or manufacture for use in California any multi-purpose solvent or paint thinner that contains greater than 1% "Aromatic Compound Content by weight". The chromatographic conditions for this procedure are based on ASTM D 5443-04, "Standard Test Method for Paraffin, Naphthene, and Aromatic Hydrocarbon Type Analysis in Petroleum Distillates through 200°C by Multi-Dimensional Gas Chromatography".

2 SUMMARY OF METHOD

SOP SAS12 is used to measure the aromatic hydrocarbons in multi-purpose solvents and paint thinners by multidimensional gas chromatography equipped with dual detectors, flame ionization and mass selective detector (FID/MSD). The system is calibrated using a standard mixture referenced in Table 7 (Appendix A) of ASTM D5443-04. The system efficiency is checked using a control standard mixture of known composition (Appendix B). Depending on sample matrix, the sample can be analyzed neat or can be dissolved in hexane or cyclohexane prior to analysis. The total aromatic content is determined by measuring the peak area of C₆ to C₁₀₊ aromatics with boiling points less than 270 degrees centigrade (°C) as compared to the total area of the chromatogram.

3 INTERFERENCES/LIMITATIONS

- 3.1 The procedure, at this time, is limited to the analysis of samples containing aromatics with boiling points lower than 270 °C and/or naphthenic/paraffinic mixtures not to exceed 16 carbon atoms.
- 3.2 Since not all compounds in the boiling point range covered in this method have been tested, it is possible that non-aromatic analytes may elute in aromatic regions of the chromatogram. The analyst must verify the spectra of peaks in the aromatic regions prior to inclusion in the final calculation.
- 3.3 A solvent blank should be run after each sample to ensure that there is no carryover and that late eluting peaks do not interfere in subsequent sample analysis.

4 APPARTUS AND MATERIALS

- 4.1 Gas chromatographic system equivalent to Agilent Technologies 7890A equipped with an FID in parallel with a 5975C MSD. The GC is modified

with one 6-port series/bypass valve, two 4-port switching valves, and one 8-port switching valve.

4.2 Three analytical columns are used:

4.2.1 Column 1, three meter x 1/8 inch diameter packed OV-275

4.2.2 Column 2, 30m x 0.53 x 1.5 μ m DB-624

4.2.3 Column 4, 1.6 meter x 1/8 inch diameter Molecular Sieve 13x.

4.3 9 inches x 1/8 inch trap (Wasson Cat # AT003) designated Column 3

4.4 Two auxiliary ovens, one set at 170°C, the other programmed from 120°C to 450°C,

4.5 Trap heater capable of heating to at least 280° C.

4.6 A schematic of the systems relevant valves, columns, and plumbing is shown in Figure 1.

5 GASES AND REAGENTS

5.1 Helium, Grade 5 for gas chromatography

5.2 Hydrogen, Grade 5 or Hydrogen generator (Whatman or equivalent)

5.3 Compressed Air, Purified

5.4 Calibration Standard: ASTM D 5443 Hydrocarbon Test Mixture (AccuStandard, Inc., Catalog Number D-5443-93-HTM or equivalent). See Appendix C.

5.5 Check Standard: Neat Standards from Sigma-Aldrich or equivalent, or a premade standard mixture from AccuStandard or equivalent (Reference # S-21417). See Appendix B.

6 ANALYTICAL PROCEDURE

6.1 Set up the GC system conditions to the following:

Injector Temperature: 250 °C

FI Detector Temperature: 275 °C

MSD Analyzer Temperature: 150 °C

MSD Interface Temperature: 280 °C

Oven Temperature Program:

Auxiliary Oven 1 for Column 1:
OV-275 Oven Isothermal at 170 °C

Auxiliary Oven 2 for Column 4:
Molecular Sieve 13x Oven programmed as follows:

120 °C for 0 minutes
20 °C/min to 350 °C for 0 minutes
15 °C/min to 450 °C for 10 minutes
4 °C/min to 120 °C for 0 minutes

GC Programmable Oven for Column 2
DB-624 Oven programmed as follows:

200 °C for 28 minutes
50 °C/min to 45 °C for 2.4 min
10 °C/min to 240 °C for 3 min
50 °C/min to 100 °C for 5 min
15 °C/min to 240 °C for 11 min
50 °C/min to 100 °C for 1 min
10 °C/min to 240 °C for 18.2 min

Injection:	Split
Injection volume:	0.1 µl
Column Flow Rate:	33 mL/min
Septum Purge:	3 mL/min
Helium Makeup Flow to FID:	5.0 mL/min
Hydrogen Flow:	35.0 mL/min
Air Flow:	200 mL/min

GC Run Time Events:

Time (min)	Position	Set point
2.2	Valve 2	On
28.2	Valve 3	On
28.2	Valve 2	Off
32.2	Valve 2	On
32.5	Valve 8	On
32.5	Valve 4	On
32.5	Valve 3	Off
33.5	Valve 4	Off
33.5	Valve 8	Off
53.0	Valve 3	On
58.0	Valve 2	Off
61.8	Valve 2	On

62.0	Valve 3	Off
62.0	Valve 4	On
62.0	Valve 8	On
64.0	Valve 4	Off
64.0	Valve 8	Off
74.0	Valve 3	On
74.0	Valve 1	On
74.0	Valve 2	Off
86.0	Valve 1	Off
86.0	Valve 3	Off
86.0	Valve 4	On
86.0	Valve 8	On
88.0	Valve 4	Off
88.0	Valve 8	Off
109.0	Valve 3	On
117.0	Valve 7	On
117.0	Valve 8	On
120.0	Valve 3	Off
120.0	Valve 8	Off
120.0	Valve 7	Off

For an explanation of the valve switching events read pages 25 through 27 in the Wasson-ECE Instrumentation's Instrument Manual.

- 6.2 Analyze a solvent blank (pentane or hexane). If there are no aromatics above 0.5% present, the system is ready for sample analysis.
- 6.3 Analyze the ASTM D5443 Calibration Standard. Check to ensure that all aromatic peaks from benzene (C₆) to pentamethylbenzene (C₁₁) are detected and their retention times have not drifted by more than 0.1 minute. If retention times have drifted more than 0.1 minute update the calibration table with the new retention times. Make sure the quantitation windows are also updated. Check quantitation to verify the amount present for each aromatic class, C₆ thru C₁₀+
- 6.4 Run the Check Standard. Check that the determined values are within 3 standard deviations of the theoretical values or no more than +/- 15% of the theoretical value.
- 6.5 Aliquot the sample to be analyzed into a 1.8 ml amber GC vial. If necessary dilute an aliquot of the sample with pentane or hexane prior to analysis. Mix well and inject 0.1 µl of the sample into the GC system. It is important that all solids be filtered out of the sample aliquot prior to analysis.
- 6.6 Samples that are high in water content must be recalculated to compensate for the water contribution to the overall weight. Water will not

chromatograph on this system and thus the total chromatographic area will over represent all analytes quantitated.

6.7 Inspect the chromatogram to determine that the baseline for each quantitation group has been drawn correctly. If not, manually adjust the baseline to best integrate the peaks. Analyze a solvent blank sample after each sample to ensure there is no carry over from the previous sample. Because this method uses area of total chromatogram and area of chromatogram for C₆ to C₁₀₊ aromatics, it is imperative that peaks must be evident in each integration group's retention time window. Using the MSD National Institute of Standards and Technology (NIST) library spectra identify each aromatic quantitated and make adjustment in quantitation for any potential coeluting analytes.

6.8 Aromatic fraction is calculated as:

Aromatic Fraction, % W/W:

$$\frac{\text{Total adjusted* area of C}_6 \text{ to C}_{10+} \text{ aromatics}}{\text{Total adjusted* area of chromatogram}} \times (1 - \text{Fractional amount of H}_2\text{O}) \times 100\%$$

- * adjusted area equals the measured area times the analytes response factor as listed in ASTM D5443-04

Figure 1
Gas Chromatograph Plumbing Diagram

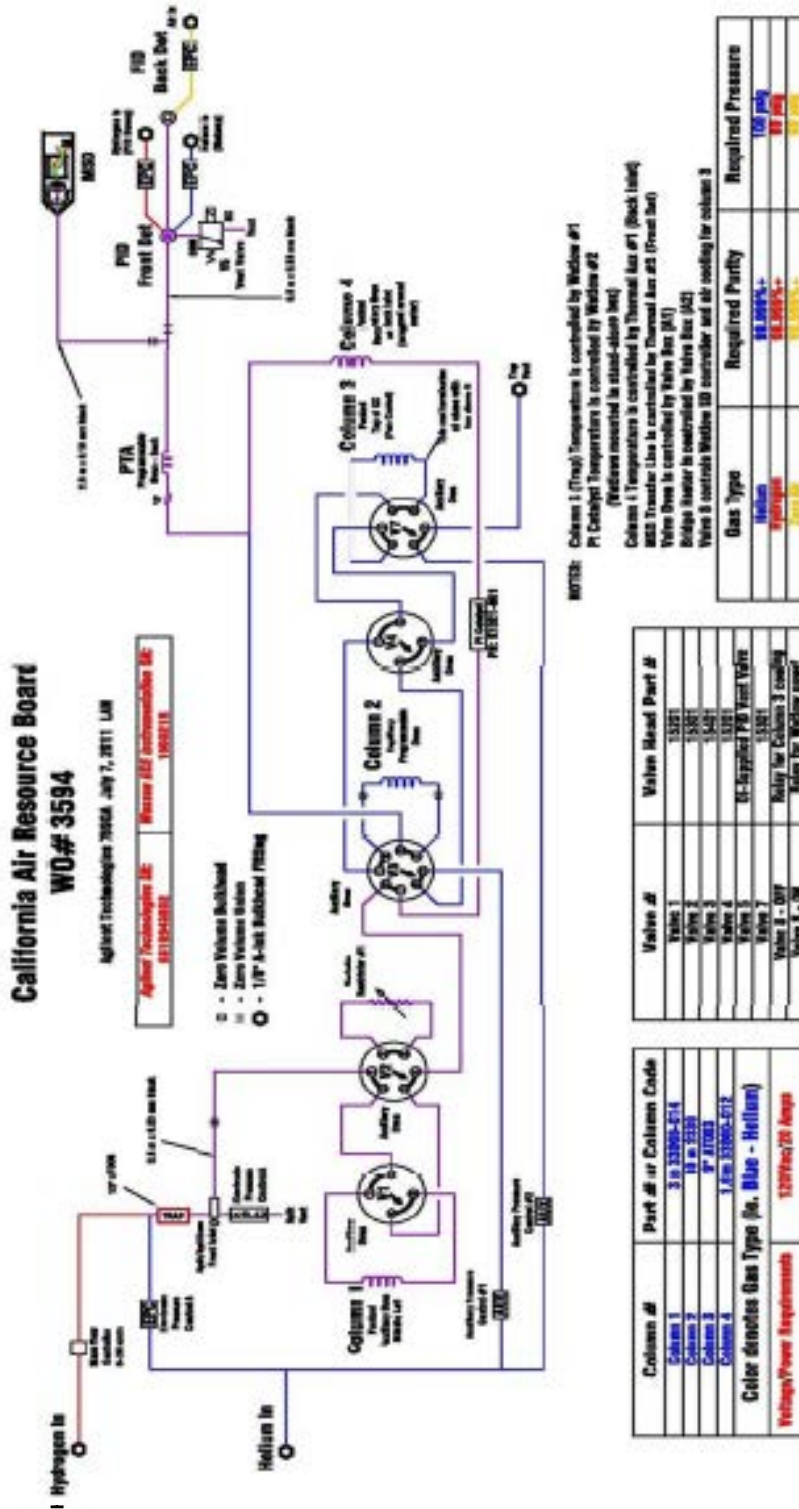

APPENDIX A

Preparation of Calibration Standard, Check Standard and Samples for Aromatics in Multi-purpose Solvents and Paint Thinners

1 CALIBRATION STANDARD

1.1 The standard to be used for calibration consists of the analytes listed in Table 7 of the ASTM D5443-04 method.

Table 7: Hydrocarbon Test Mixture Component Identification

Number Identification	Component Name
1	Cyclopentane
2	n-Pentane
3	Cyclohexane
4	2,3-Dimethylbutane
5	n-Hexane
6	1-Hexene
7	Methylcyclohexane
8	4-Methyl-1-Hexene
9	n-Heptane
10	1-cis-2-Dimethylcyclohexane
11	2,2,4-Trimethylcyclopentane
12	n-Octane
13	1,cis-2-cis4-Trimethylcyclohexane
14	n-Nonane
15	n-Decane
16	n-Undecane
17	n-Dodecane
18	Benzene
19	Toluene (methylbenzene)
20	trans-Decahydronaphthalene (Decalin)
21	n-Tetradecane
22	Ethylbenzene
23	1,2-Dimethylbenzene (o-Xylene)
24	n-Propylbenzene
25	1,2,4-Trimethylbenzene
26	1,2,3-Trimethylbenzene
27	1,2,4,5-Tetramethylbenzene
28	Pentamethylbenzene

- 1.2 The calibration standard can either be purchased or made from individual components. At this time the lab is purchasing the calibration standard. The commercially available calibration standard is accompanied with a Certificate of Analysis which lists the concentrations of each component to two decimal places. (Appendix C)
- 1.3 The listed concentrations are used to verify instrument quantitation accuracy. Concentrations for each analyte should be in the 2% to 5% range and the total percentages should add up to 100%.
- 1.4 Quantitation is based on response factors listed in ASTM D5443. For analytes not listed in ASTM D5443 (oxygenates) a response factor is determined by analyzing a pure analyte standard or by using the response factor for acetone as a default value.
- 1.5 A single-point calibration is used when screening for the complete list of aromatics. If only one or two aromatics are present and identifiable then a multipoint calibration curve should be prepared encompassing the suspected concentration of the aromatics. The low point of the curve should be less than 1 % to validate the minimum required detection limit.
- 1.6 Prior to analyzing the calibration standard, transfer 250 µl to an amber vial equipped with a 250 µl insert. Transfer the remaining standard to an amber vial and store in a refrigerator at 4°C. Date vial and use the remaining within 60 days of opening.
- 1.7 The calibration standard will be run with each batch of samples prior to the check standard.

2 PREPARATION OF CHECK STANDARD

- 2.1 To prepare the check standard obtain 98+% pure standards of the following analytes: Hexane or cyclohexane, benzene, toluene, ethylbenzene, o-xylene, 1,2,4-trimethylbenzene, 1,2,4,5-tetramethylbenzene, pentamethylbenzene, and hexylmethylbenzene. The concentration of all aromatic analytes should be in the 2 to 5% range with the remainder being hexane or cyclohexane. (Appendix B)
- 2.2 This check standard should be stored in amber vials and refrigerated. This standard is good as long as it is within +/- 15 % of the true value or less than three standard deviations from the true value as determined by the total check standards run.

3 GC INSTRUMENT CALIBRATION SETUP

- 3.1 The analysis of the calibration standard should occur prior to each new batch of samples. The calibration standard is used not only to establish retention time and response for each aromatic group, but is also used to verify that the GC valve timing is making the chromatographic cuts properly.
- 3.2 The instrument calibration standard is used to verify expected concentration for each aromatic group versus the total chromatographic area.
- 3.3 Fill and cap a GC vial with pentane or hexane. This will be the solvent blank.
- 3.4 Place GC vials in the autosampler in the following order: vial position 1 - solvent blank, vial position 2 – calibration standard, vial position 3 – solvent blank , vial 4 - check standard.
- 3.5 Go to the sequence pull down menu. Select sequence parameters. Enter user initials. Make sure the Path is as follow: C:\Chem32\Data\ and the subdirectory is Aromatics 2011 (current year). The “Part of Method to run” should be “According to Runtime Checklist.” At this point select OK. Select “Sequence Table.” The first five lines should include:
 - Line 1: pentane or hexane blank. Do not make any changes to this line.
 - Line 2: calibration standard.
 - Line 3: blank.
 - Line 4: check standard.
 - Line 5: blank.

In all cases make sure the method being used is the current aromatic method **PNAFF**. Select OK. Select the sequence pull down menu again and select “Save sequence as.” Enter CalIMMDDYY (current date). Select enter/OK. A window should appear asking to create a new file for the data. Select “yes.” From the sequence pull down menu select print to print the sequence list.

- 3.6 Go to the run control pull-down menu; select run sequence.
- 3.7 After the analysis, the GC should automatically go into standby mode. If it does not, go to the view pull-down menu; select method. At the method pull-down menu, select **PNAstandby** method. Hit enter.

4 CALIBRATION REPORT

- 4.1 The analysis of the calibration standard produces a report consisting of:

- 4.1.1 A chromatogram of both the FID and MSD traces.
 - 4.1.2 External Standard Report using the FID signal lists the retention times, areas, percent and analyte or group name for both detectors.
 - 4.1.3 A summary report (Appendix D) is generated after the analysis, and is used to summarize the Chemstation quantitation report into aromatic and non-aromatic groups.
 - 4.1.4 The report includes a summary sheet listing the C5 to C11+ paraffins and naphthenes group totals and the C6 to C10+ aromatic groups, and a calculation sheet showing the total areas and response factors used in the calculations.
 - 4.1.5 If the chromatogram is edited after the run is completed then the external report will need to be generated manually.
 - 4.1.6 At the command line on the data analysis screen type "macro astm5443" then return. Afterwards in the same command line type "astm5443." This will generate the report and store it under the filename in the data folder.
 - 4.1.7 The data folder is accessed at C:\msdchem\1\data\Aro2011\filename.
 - 4.1.8 Open this up and open file with the following name: ASTM5443.xls.
- 4.2 Check the retention time and summed percentage to confirm that the instrument is functioning properly. Check the theoretical values for the standard mix to ensure that the integration was done correctly. If not manually integrate the affected peaks and recalculate the final values and reports. If values are not acceptable ($\pm 15\%$), then rerun using a fresh standard. If still out, check with service provider for possible hardware problems.
- 4.3 Figure 2 shows a typical calibration standard FID chromatogram.
- 4.4 The Check standard generates a report similar to the calibration report.
- 4.5 Review the Check standard and make sure the values for the control analytes are within $\pm 15\%$ or 3 standard deviations from the theoretical value. If the values are outside these ranges double check the peak quantitation and regenerate the report. If still out of control then rerun the check standard. If values are not acceptable ($\pm 15\%$), then rerun using a fresh standard. If the check standard is still out, check with service provider for possible hardware problems.

5 SAMPLE PREPARATION

NOTE: Samples may be diluted or run neat depending on sample viscosity. Samples with high water content will result in higher than expected values for aromatics. The fractional amount of aromatic will need to be adjusted to compensate for the high water content. See calculation in section 7.3.

- 5.1 For neat samples transfer 250 μ l to a GC vial equipped with a 250 μ l glass insert. Label with appropriate sample ID.
- 5.2 Samples requiring dilution or other preanalysis preparation are to be weighed to nearest tenth of a milligram before and after dilution. Use these values to determine the dilution factor. Dilute the sample with hexane or cyclohexane and use syringe micro filters to filter solids from the sample.
- 5.3 After sample preparation transfer 250 μ l to a GC vial equipped with a 250 μ l glass insert. Sample is ready for analysis.

6 GC INSTRUMENT SETUP FOR SAMPLES

- 6.1 Place samples in the autosampler in the following order: position
 - o 1: Hexane blank
 - o 2: check standard
 - o 3: hexane blank
 - o 4: samples.

All samples should be followed by a hexane blank. This sequence can be added to the calibration sequence starting after the initial check standard.

- 6.2 A check standard should be run at the end of each analytical batch, or after every tenth sample analyzed in a batch.
- 6.3 Follow the sequence set up routine as outlined in section 3.5. Make sure that the ending run, after the last sample, is either a non-inject using the standby-PNA method or the PNAclean method.

7 SAMPLE RESULTS

- 7.1 The PNAFF method generates the following reports for each sample analyzed:

- 7.1.1 A chromatogram of both the FID and MSD traces.

- 7.1.2 External Standard Report listing the retention times, areas, percent and analyte or group name.

- 7.1.3 An external report summarizing the total percent weight of each aromatic group from C₆ to C₁₀⁺.
- 7.2 For each aromatic group detected staff must check the baseline to ensure accurate integration and the NIST library spectrum to insure accurate identification.
- 7.3 Find the % aromatic mass for each aromatic group on the sample report. Make adjustments according to whether the sample was diluted, or if the sample has a high water content.

%Aromatic in waterless samples

$$\frac{\text{Total adjusted* area of C}_6 \text{ to C}_{10+} \text{ aromatics}}{\text{Total adjusted* area of chromatogram}} \times \text{DF} \times 100\%$$

%Aromatic in water containing samples

$$\frac{\text{Total adjusted* area of C}_6 \text{ to C}_{10+} \text{ aromatics} \times (1 - \text{Fractional amount of H}_2\text{O}) \times \text{DF}}{\text{Total adjusted* area of chromatogram}} \times 100\%$$

DF = dilution factor (Final volume/ sample volume)

* = integrated area times response factor as listed in ASTM D5443-04

- 7.4 Report the % Aromatic content on the consumer products laboratory report sheet under % Aromatic Modified ASTM D5443.

Appendix B

Check Standard Mixture

Component Name	Concentration w/w%
Benzene	2
Toluene	2
Ethylbenzene	2
o-xylene	2
1,2,4-Trimethylbenzene	2
1,2,4,5-Tetramethylbenzene	2
Pentamethylbenzene	2
Hexamethylbenzene	2
Hexane(cyclohexane)	84

Appendix D

Aromatic Summary Report

WASSON+ECE INSTRUMENTATION

Sample: D6443 STD Date/Time: 13 Oct 2011 10:35
 Operator: MWO Data File: STD101311.D
 Sample Info.: 13 Oct 2011 10:35 Method File: PNAFF.M
 ASTM D5443-04

Liquid Volume % Values

Carbon No.	Naphthenes	Paraffins	Aromatics	Total
4	---	0.00	---	0.00
5	1.23	1.15	0.87	2.02
6	2.56	2.42	5.70	11.39
7	5.54	5.23	0.00	8.38
8	9.07	8.04	0.00	21.07
9	6.20	6.13	0.00	20.92
10	0.00	0.00	5.32	5.32
11	0.00	0.00	4.27	4.27

Weight % Values

Carbon No.	Naphthenes	Paraffins	Aromatics	Total
4	---	0.00	---	0.00
5	1.23	1.15	0.87	2.38
6	2.56	7.01	2.84	12.42
7	5.54	0.00	2.94	8.48
8	9.07	0.00	11.00	20.07
9	6.20	0.00	19.47	25.67
10	0.00	5.84	---	5.84
11	0.00	4.68	---	4.68

Totals	24.60	18.68	36.86	80.14
C10+ Aromatics				13.02
C11+ Paraffins				6.82
Polynaphthenes				0.00
Unknown Oxygenates				0.01
tert-Amyl Alcohol				0.00
Total				100.00

Totals	23.56	16.15	39.59	79.30
C10+ Aromatics				13.99
C11+ Paraffins				6.70
Polynaphthenes				0.00
Unknowns				0.01
tert-Amyl Alcohol				0.00
Total				100.00

Totals	23.56	16.15	39.59	79.30
Naphthenes + 2* Aromatics				130.71