

**ASSESSMENT OF ETHYLENE OXIDE CONCENTRATIONS AND EMISSIONS
FROM STERILIZATION AND FUMIGATION PROCESSES**

**Final Report
Contract No. A832-125**

Prepared for:

Research Division
California Air Resources Board
2020 L Street
Sacramento, CA 95814

LIBRARY
CALIFORNIA AIR RESOURCES BOARD
P.O. BOX 2815
SACRAMENTO, CA 95812

Submitted by:

Coast-to-Coast Analytical Services
141 Suburban Road
San Luis Obispo, CA 93401

Prepared by:

Stephen C. Havlicek
Lawrence R. Hilpert
Gesheng Dai
David Pierotti

MAY 1992

ACKNOWLEDGMENT

The research presented in this report was funded by the California State Air Resources Board (CARB) under contract number A832-125. Coast-to-Coast Analytical Services, Inc. (CCAS) is pleased to have been allowed to perform this interesting and important work and is grateful to CARB for providing CCAS with both the opportunity and the funding.

CCAS acknowledges the comments and suggestions provided the CARB reviewers, especially Mr. Ralph Propper, who offered many helpful suggestions along the way.

CCAS wishes to thank Mr. Paul Kelley and the Finnigan MAT corporation of San Jose for providing the use of the Ion Trap mass spectrometer upon which some of the research was performed.

CCAS acknowledges the dedication of its scientists and support personnel who were always willing to put forth the extra effort required to make the project a success.

DISCLAIMER

The statements and conclusions in this report are those of the Contractor and not necessarily those of the State Air Resources Board. The mention of commercial products, their source or their use in connection with material reported herein is not to be construed as actual or implied endorsement of such products. Comparisons with published health risk assessment data do not constitute an actual risk assessment and are presented for informational purposes only.

ABSTRACT

Recent concern regarding the mutagenic and carcinogenic properties of ethylene oxide has created the need for the development of sensitive analytical methods capable of determining the presence of ethylene oxide in air samples at levels ranging from 5 pptv in ambient background samples to near percentage levels in process vent streams. Accordingly, the California State Air Resources Board (CARB) selected Coast-to-Coast Analytical Services, Inc. (CCAS) to develop analytical methods which would be capable of spanning these extremely broad concentration ranges.

This research verified that samples could be collected cryogenically using U-Tubes or using SUMMA electropolished stainless steel canisters. In both cases, samples suspected of containing acid mists could safely be passed through a sodium bicarbonate cartridge during collection in order to prevent post-collection breakdown. Samples collected by the U-Tube method may be held indefinitely while those collected in canisters require a more immediate analysis, particularly if concentrations are expected to be below 1 ppmv. Due to differences in the ways in which samples are transferred to the instrumentation, lower detection limits are provided if samples are collected by the U-Tube method.

The methods listed below were developed and found to be effective. In the case of the vent stream method, NIOSH had already published the range and detection limit data which made it unnecessary for CCAS to independently develop these data. Except for the NIOSH method, the detection limits presented below are for U-Tube sample collection.

1. Ion Trap GC/MS - This method was found to be the most sensitive with a detection limit of 1 pptv.
2. Quadrupole GC/MS with Selective Ion Monitoring - This method was found to be almost as sensitive with a detection limit of 10 pptv.
3. Gas Chromatography with Photoionization Detection - The detection limit afforded by this method is dependent upon the energy of the light source. With a 10.6 ev lamp, the detection limit was 10 pptv. With a 10.0 ev lamp, the detection limit was 10 ppbv.
4. Quadrupole GC/MS with Full Scan Monitoring - This method was found to provide a detection limit of 0.1 ppbv.
5. Portable Gas Chromatograph with Photoionization Detection - Presumably the detection limit would also depend upon the energy of the lamp. Since sample preconcentration is impractical in the field, the detection limits developed by NIOSH are only 1 ppbv.

Since ambient samples could be collected in areas accessible to the general public, several hundred such samples were collected. In most cases the U-Tube method was employed. Some key results are listed on the next page.

1. Samples collected at remote coastal locations indicated that the global tropospheric background in the Northern Hemisphere is between 15 and 25 pptv.

2. Samples collected away from known sources in several urban California locations showed levels ranging from the global background to an order of magnitude higher.

3. Samples collected near suspected sources in several urban California locations showed levels ranging from the global background to more than 1 ppmv.

4. Samples collected from one process stream before and after the control devices exhibited greater variability than expected with levels ranging from 3 ppbv to nearly 0.2%.

TABLE OF CONTENTS

1.0	Introduction	1
	1.1 Background	1
	1.2 Statement of the Problem	2
	1.3 Project Objectives	2
	1.4 Methods Considered	3
2.0	Sampling Considerations	5
	2.1 General	5
	2.2 U-Tube Method	6
	2.3 Canister Method	8
	2.4 Canister Cleaning	12
	2.5 Transfer from Canisters to the Analytical System	14
	2.6 Stability of Ethylene Oxide in Canisters	17
3.0	Development of Test Methods for Sterilizer Gas Vent Streams: Photoionization Detector	19
	3.1 Equipment	19
	3.2 Reagents	19
	3.3 Procedure	19
	3.4 Assembly of Transfer Apparatus	22
4.0	Development of the Test Method: Ion Trap GC/MS	23
	4.1 Equipment	23
	4.2 Reagents	24
	4.3 Procedure	24
5.0	Development of the Test Method: Quadrupole GC/MS	25
	5.1 Equipment	25
	5.2 Reagents	27
	5.3 Procedure	27
6.0	Results and Discussions	30
	6.1 Calibrations	30
	6.2 Detection Limits	30
	6.3 Ambient Surveys	31
	6.4 Source Tests	33

APPENDIX

List of Tables	I
Exhibit List	XVI
Reference List	XXXIV

SECTION 1 - INTRODUCTION

1.1 Background

Ethylene Oxide (EO) has been listed by the Air Resources Board of the State of California as an identified toxic air contaminant. Ambient exposure levels estimated by modeling were believed to range from 9-50 pptv with higher levels being expected in the vicinity of large uncontrolled users. At the time of project initiation, June 1989, both the expected ambient levels and the levels at which health effects were believed to be operative were below the best analytical detection limits then available. In order to close the gap between higher detection limits and low health effect threshold concentrations, Coast-to-Coast Analytical Services (CCAS) was contracted by the Air Resources Board (#A832-125) to develop new methods and/or extend the lower limits of detection for existing methods for the analysis of EO. While the development of both ambient and source test methods was within the scope of the work authorized, earlier efforts were directed towards providing detection limits which were at least as low as the expected ambient exposure levels. It was believed that this strategy, followed by a number of regional surveys, would immediately focus on the magnitude of any problems which might be caused by the release of ethylene oxide into the atmosphere. Positive findings would then be cause for shifting emphasis towards the development of improved source testing methods and their application to selected sites within the State of California.

Ethylene oxide is used in large commercial sterilizers from which it may be emitted as a fugitive emission. Emission control systems which have been developed for such large facilities generally take advantage of the reactivity of ethylene oxide towards aqueous acid thereby removing better than 99 percent of the treated ethylene oxide as ethylene glycol. At the time of project initiation, however, most facilities were uncontrolled. Furthermore, even in the vicinity of partially controlled and smaller facilities, ethylene oxide levels were predicted to be sufficiently high to pose a potential health risk - particularly to women of childbearing age according to a study published by EPA in 1988 (1). The cited reference studied 203 facilities - 21 of which were in the State of California. Emissions from these California facilities, if in proportion to those of all the facilities studied, would have been 220 tons/yr. Since the issuance of the report, many of these facilities have added controls and/or curtailed operations so that present totals may be lower. Hospital and clinical sterilization units are more numerous, smaller and generally uncontrolled and were not included in the aforementioned study. Furthermore, ethylene oxide has other commercial uses in addition to sterilization and fumigation. A summary of chemical reactions of commercial interest is presented as Exhibit 1. Familiar products represented by these processes include ethanolamines, nonionic detergents, ethylene glycol, diethylene glycol, triethylene glycol, cellosolves, carbitols and other glycol ethers and esters. While fugitive emissions from these sources were not part of the planned research, the methods developed will be equally applicable for the monitoring of all potential sources.

Some of the properties of ethylene oxide are presented below for the convenience of the reviewer. Wherever possible, the CCAS approach took advantage of these properties in order to select and develop the methods eventually validated for use in the collection and analysis of real samples.

1.1.1 Boiling Point 10.7°C - suggested that concentrative cryogenic transfer during collection and/or analysis would be successful in improving detection limits.

1.1.2 Ethylene oxide is a small molecule containing two carbon atoms, four hydrogen atoms and an oxygen atom in the form of a three-membered ring. The molecule is polar and chemically reactive.

1.1.3 Ethylene oxide has a photoionization potential (10.6 eV) which is low enough for the development of a selective gas chromatographic method based on photoionization detection (PID) using a lamp having a higher energy.

1.2 Statement of the Problem

The use of ethylene oxide in sterilization, fumigation and other chemical processes appears to provide the opportunity for the escape of sufficient quantities of ethylene oxide to be of concern both locally and remotely. The development of analytical methods which are characterized by having detection limits below both the expected ambient levels and the minimum levels believed to be of concern for the protection of the public is necessary. The methods developed for sample collection and analysis must be tested for ruggedness through the collection of large numbers of samples covering a wide range of concentrations.

This document provides evidence that the problem, as defined above and as limited only by the availability of funds and the logistics of obtaining permission for on site testing of facilities, has been solved by the work performed by Coast-to-Coast Analytical Services, Inc.

1.3 Project Objectives

1.3.1 Identification of Potential Test Methods - One of the first tasks slated to be undertaken was the searching of the literature in order to identify available and potential test methods capable of determining ethylene oxide at ambient levels, "hot spot" levels and at source levels. The merits of candidate methods were to be evaluated against such criteria as convenience of sampling, stability of samples, ease with which samples and sample collection equipment might be transported, detection limits, simplicity of the analytical protocol, nature of interferences, precision, accuracy, cost of necessary equipment, level of training needed to perform the analysis, the ability to establish quality control and the influence of meteorological conditions.

1.3.2 Identification of Practical Alternate Methods and Modifications - Another early task slated to be carried out was selecting a limited number of the identified methods for preliminary development.

1.3.3 Identification of Applicable Quality Assurance Measures - Elements of quality assurance which would need to be incorporated into any quality assurance (QA) program were to be evaluated early in the program. These

included documentation of chain of custody, replicates, spiked samples, certified reference standards, internal standards, calibration frequency, method blanks, verification by alternate methods, sampling blanks, sample stability, reagent blanks, record keeping, archiving raw data, documentation of sample security, injection records, instrument maintenance, data review and certification of analysts.

1.3.4 Validation of Detection Limits - As methods were brought to the bench, informal and preliminary assessments of the detection limits were to be made on the basis of signal to noise ratios. Methods developed beyond the preliminary stage were to be subjected to the statistical development of a detection limit according to the method of Glaser (2).

1.3.5 Monitoring - A major project objective was the use of one or more of the developed methods for monitoring ambient levels, hotspot levels and source levels. This objective was fully realized for ambient and hotspot levels. Source testing, however, was dependent upon coordination between the State, the source and CCAS. Even though additional time was made available for source testing, fewer tests were arranged than originally planned.

1.4 Methods Considered

1.4.1 Flame Ionization Detector (FID) - A publication by the Radian Corporation compared sampling container types and chromatographic techniques for the analysis of ethylene oxide in scrubber vent streams from a commercial sterilization facility using the FID as the only detector type (3). Since the FID is very sensitive, the reported minimum detection limit of 60-80 pptv needed only slight improvement to meet the needs of even an ambient method. However, the fact that this detector responds equally well to a wide variety of potential interferents caused CCAS' researchers to dismiss the method without even a preliminary trial. We did not believe that the State would be well served by a method which might not stand up in court.

1.4.2 Derivatization/Electron Capture Method - NIOSH Method 1614 takes advantage of the reactivity of ethylene oxide towards hydrobromic acid (top reaction, Exhibit 1) to convert ethylene oxide to the less volatile 2-bromoethanol (4). The adsorbed 2-bromoethanol is then desorbed from the sampling cartridge with dimethylformamide (DMF) and converted to the more volatile, more strongly electron capturing heptafluorobutyrate ester by reaction with N-heptafluorobutyrylimadazole. The resulting 2-bromoethanolheptafluorobutyrate is then quantitatively determined by electron capture gas chromatography. NIOSH estimates the limit of detection to be 20 ppbv if 25 liters are sampled. As it stands, this method may be considered validated for source testing since NIOSH procedures are required to be thoroughly documented prior to publication. Sampling cartridges are commercially available.

We had originally planned to attempt to extend this method another three orders of magnitude by exploring the use of alternate desorption methods for the 2-bromoethanol which would have permitted the subsequent concentration of the desorbed 2-bromoethanol either prior to or following derivatization. However, progress with other methods removed the need for this line of method extension research.

1.4.3 Photoionization Methods - As NIOSH Method 3702, this method has also been extensively tested and validated at source type levels (5). The PID detector is selective towards ethylene oxide in that it is capable of photoionizing ethylene oxide which has a photoionization potential of 10.6 ev without ionizing such potential interferants as Freon 12 (ionization potential 12.3 ev) or carbon dioxide (ionization potential 13.8 ev)(6). The claimed detection limit of 1-2 ppbv was developed using a packed column with no sample preconcentration and is suitable for hotspots as well as source testing. In our hands, however, the practical detection limit has proven to be 10-100 ppbv, not the 1-2 ppbv claimed.

Reference material obtained from the manufacturer of a field PID gas chromatograph describes the use of the method at a commercial sterilization facility (7). In this study analyses were performed in the field at two minute intervals behind a commercial sterilizer, near the inlet plumbing to the sterilizer and in an aeration area in which sterilized products were allowed to outgas. Results from the three respective areas exhibited the following ranges:

1.4.3.1 Behind Sterilizer - 0.1-0.6 ppmv

1.4.3.2 Near Inlet - 0.3-0.5 ppmv

1.4.3.3 Aeration Room - 2.3-12 ppmv

The use of cryogenic preconcentration and capillary column separation as planned extensions of the method proved to be effective in bringing the method forward as a suitable candidate for ambient testing as well. Ambient air, however, does contain other chemical species which may have similar chromatographic behavior and which might also produce a response on the PID. Several of these are listed below:

1.4.3.4 1-Butene - ionization potential 9.6 ev.

1.4.3.5 2-Butene - ionization potential 9.1 ev.

1.4.3.6 Isobutene - ionization potential 9.2 ev.

1.4.3.7 Acetaldehyde - ionization potential 10.2 ev.

1.4.4 Quadrupole GC/MS - EPA Method TO-14 describes the sampling and analysis of ambient air using SUMMA electropolished stainless steel canisters, cryogenic preconcentration, Nafion drying, capillary column separation of sample components and quantitative determination by GC/MS (8). At the time of project initiation, CCAS was already employing this method for routine analysis of ambient air samples with a nominal detection limit of 0.1 ppbv for most volatile organic compounds. It was expected that the selective ion modification of this method would be capable of lowering the detection limit to about 5 pptv while still allowing the use of two ions in order to avoid difficulties arising from coeluting interferences. This consideration was believed to be important due to the likelihood that carbon dioxide, propane and acetaldehyde, all with the same molecular weight as ethylene oxide might be present and possibly might also coelute. Fortunately, the species in question did not coelute nor did they produce identical fragmentation patterns as shown in Exhibits 2 and 3. The reader is advised that potential interferences for the GC/MS method were selected because they all have the same molecular weight as ethylene oxide, whereas the potential interferences for the PID methods were selected because they all had lower ionization potentials than ethylene oxide. Preliminary work was carried out with the expected degree of success but was not pressed to completion due to the more spectacular results obtained with the closely related ion trap GC/MS method.

1.4.5 Ion Trap GC/MS - EPA Method TO-3 describes the sampling and analysis of ambient air samples by cryogenic collection in U-tubes packed with glass beads, Nafion drying, capillary column separation of sample components and quantitative determination of volatile organics by GC/ECD/FID (9),(10). In our case, we substituted a two-dimensional chromatographic system for the Nafion dryer since preliminary testing had indicated that this type of dryer would destroy ethylene oxide. Since the ion trap detector is inherently more sensitive than the quadrupole mass spectrometer, it was felt that a sensitivity equal to or greater than that available through quadrupole mass spectrometry with selective ion monitoring could be obtained without sacrificing the discriminatory features of full scan mass spectrometry. This method was to become the most frequently used and the most extensively developed of those considered.

SECTION 2 - SAMPLING CONSIDERATIONS

2.1 General - Air samples may be collected in Tedlar or Teflon bags, gas tight syringes or bulbs, solvent desorbable cartridges, thermally desorbable cartridges, U-tubes or SUMMA electropolished canisters. Fears regarding the possible loss of ethylene oxide through permeation of the walls led us to believe it would not be worthwhile to explore the use of bags as sample containers for ethylene oxide monitoring. The solvent desorbable cartridge employed by NIOSH Method 1614 employs the simultaneous conversion of the ethylene oxide to a less volatile derivative and therefore does more than just adsorb the EO. This method, as previously stated, is proven to work for source testing. Thermally desorbable cartridges, in principle, ought to work provided breakthrough volumes for EO were not too low. This avenue was not explored. Gas tight syringes and bulbs have not been proven to be generally satisfactory for anything but extremely short term storage of volatile organics and were, therefore, not studied. Electropolished canisters, on the other hand, have been demonstrated to be generally satisfactory for the long term storage of even low level non polar samples destined for volatile organics analysis. Since project initiation, evidence gathered both in our own laboratory and reported by others in the literature makes it clear that, at low levels, polar organics such as ethylene oxide are stable for only short periods of time when stored in electropolished canisters. Their use was therefore evaluated in connection with this project. Likewise, the collection of air samples in cryogenically cooled U-tubes packed with glass beads has been proven to be generally successful for the analysis of very low levels of trace organics in ambient air. This method was therefore evaluated for use in support of this project.

Due to the fact that many types of commercial ethylene oxide scrubbers employ aqueous acid to destroy EO, it was felt that collection in canisters or U-tubes might produce misleading results regarding scrubber efficiencies if there was any potential to co-collect acid mists. In order to test a method by which this possible difficulty could be circumvented, an ethylene oxide standard at approximately 100 ppbv was passed through a sodium bicarbonate cartridge and analyzed. As shown in Exhibit 4, the instrument responses with and without prior passage through sodium bicarbonate were identical thereby demonstrating that samples collected from acid scrubber exhausts could be safely collected without accidental cocollection of acid mists. Since plans to sample several commercially installed acid scrubbers never materialized, authentic acid scrubber exhausts were never sampled. Thus we were only able

to establish that passage through sodium bicarbonate which ought to have neutralized acid mists did not also destroy the ethylene oxide. We have presented a solution for a potential problem. Repetitive analysis of samples known to contain both ethylene oxide and acid mists would, of course, be necessary to establish the advantages of following this protocol. This issue has been raised, however, simply because passage through sodium bicarbonate, if included in all source testing protocols, could be viewed as useful "insurance", possibly unnecessary, but demonstrated not to be harmful.

2.2 U-Tube Method - Adapted from EPA TO-3. This method of collection may be followed by analysis by the photoionization method, quadrupole GC/MS or by ion trap GC/MS. The method is based on the collection of whole air samples in cryogenically cooled U-tubes. Samples from scrubber vents employing aqueous acid should first be passed through a cartridge containing granular sodium bicarbonate in order to avoid the possible accidental cocollection of acid mists which might subsequently destroy the target analyte.

2.2.1 Equipment - Assembled as shown in Exhibit 5. A Pump draws air through sampling lines made entirely of Teflon tubing, heavy walled 1/4" OD. All fittings are made of Teflon. All pump and valve surfaces are constructed of Stainless Steel or Teflon. The pump outlet passes through the U-Tube which is immersed in liquid argon. A flow meter is placed on exit side of U-Tube.

2.2.1.1 Sampling Pump - XonTech Model 3100 or equivalent, equipped with mass flow controller capable of operating over 5-1000 mL/min range, battery or line operation.

2.2.1.2 U-Tube - Constructed of heavy walled borosilicate glass, 1/4" OD, 1/8" ID, partially filled with silanized glass beads 1.0 mm diameter. All U-Tubes should be clearly marked with a unique number. See Exhibit 6.

2.2.1.3 Dry Test Meter - Singer Model DTM-115-3 or equivalent. Capable of measuring flows in the sampling range to +/- 1%

2.2.1.4 Shipping Container - Taylor-Warton or equivalent. Containers of this type are readily accepted by couriers as they will not spill liquid argon even if tipped during shipment.

2.2.1.5 Sample Transfer System - Equipped with a source of cryogenically purified nitrogen, a 4-port valve, a thermos for cryogen, a thermos for hot water and a packed precolumn 1.2m X4 mmID glass, filled with 15% BCEF on 60-80 mesh gas chrom QII. Assembled as shown in Exhibit 7.

2.2.1.6 Tekmar Model 1000 cryogenic focussing capillary interface or equivalent containing a short length of uncoated capillary tubing (0.32 mm ID).

2.2.1.7 Sodium Bicarbonate Cartridge - This cartridge is needed if acid mists may be present in the volume of air to be sampled. A 1/2" OD stainless steel or glass tube is packed with sodium bicarbonate 40/80 mesh for a distance of approximately 2 inches. The packing at both ends is held in place with glass wool. The cartridge is emplaced on the inlet side of the U-Tube. Swagelok fittings are recommended for adapting the cartridge to the diameter of the rest of the sampling system. A diagram is presented as Exhibit 8.

2.2.1.8 Precolumn 1/8" x 1.0 m, packed with 15% BCEF on 60/80 mesh gaschrom QII.

2.2.1.9 Analytical column - 0.255 mm x 30 m, DB-5, J & W Scientific or equivalent.

2.2.2 Reagents

2.2.2.1 Liquid Argon - Most economic grade available.

2.2.2.2 Glass Beads - Alltech 01.0 mm. or equivalent.

2.2.2.3 Teflon Tubing - Alltech 3/8, 1/8 or equivalent. It is advisable to batch test for cleanliness before use.

2.2.3 Procedure

2.2.3.1 Assemble the complete sampling system in the laboratory. Verify it to be free from contamination by purging, then collecting and analyzing a 10 L sample of cryogenically prepurified zero air. Use within 24 hrs.

2.2.3.2 Assemble the system as shown in Exhibit 5. Record number of U-Tube sampler in field notebook. The end of the sampling line should be at breathing height in an open area free of obstacles capable of creating turbulence. Sampling during precipitation is not recommended. Plan to collect 5-10 L of air for ambient sampling. One liter is sufficient for "hot spots".

2.2.3.3 Purge the sampling system with the air to be sampled for at least five minutes WITHOUT the U-Tube being immersed in liquid argon. Then divert the flow from the sampling tube by switching the 3-way valve so that the sampling tube may be immersed in the liquid argon.

2.2.3.4 Begin collecting the sample as soon as the cryogen stops boiling rapidly. This requires only that the 3-way valve be returned to the sampling position. Sampling is continued until the desired volume has been measured by the metering device at which time the 3-way valve is returned to the vent position.

2.2.3.5 Disconnect the U-Tube from the sampling assembly WITHOUT removing it from the liquid argon. WHILE STILL IN THE CRYOGEN, seal with the brass end cap and Swagelok Teflon fitting.

2.2.3.6 Rapidly transfer to storage container filled with liquid argon. Samples may be stored under liquid argon for at least three months.

2.2.3.7 Verify U-Tube number corresponds to entered data. Record sampling data in field notebook.

2.2.4 Transfer to the Analytical System - This step is described in conjunction with the sampling protocol because the U-Tube sample collection method cannot be used with Nafion drying on the sample inlet side. Therefore, considerable water is cocollected and must be eliminated during sample transfer without the use of Nafion. The application of two dimensional chromatography selectively retards water on a precolumn while allowing the target analytes to pass through at their original concentrations.

2.2.4.1 The transfer system shown in Exhibit 7 utilizes two dimensional gas chromatography to selectively remove the water which is incidentally cocollected with the samples. A polar precolumn is selected which significantly retards water vapor while permitting even a relatively polar compound such as ethylene oxide to elute first.

2.2.4.2 The U-Tube, still immersed in cryogen, is connected to a 4-port switching valve while being flushed with cryogenically purified nitrogen. This step serves to prevent the intrusion of laboratory air.

2.2.4.3 Upon removal of cryogen, the 4-port valve is switched so that carrier gas now passes through the U-Tube. The U-Tube is immediately immersed in hot water (95-100°C) causing rapid desorption of the sample while sweeping it into the injection port.

2.2.4.4 The first 10-15cm of the precolumn is maintained at 60°C while the remainder may be also held at 60°C or programmed to a higher temperature as required to allow the elution of higher boiling target analytes. The flow of carrier gas through the precolumn should be about 30 mL/min.

2.2.4.5 As the effluent containing the ethylene oxide and other compounds of interest exits the precolumn, it passes through a 6-port capillary switching valve. Following a brief venting period, the valve is switched, directing the flow from the precolumn onto a section of uncoated fused silica capillary column (0.32 mm ID) which passes through a Tekmar Model 100 cryogenic-focussing capillary interface maintained at -150°C thereby trapping the target analytes.

2.2.4.6 After 8-10 minutes the capillary valve is switched back to its original position. Subsequent heating of the capillary interface contained within the Tekmar 1000 serves to transfer the target analytes to the analytical system. During this time, the water slowly elutes from the precolumn and is vented to the atmosphere.

2.3 Canister Method - Adapted from EPA TO-14. This method of collection may be followed by analysis by the photoionization method, quadrupole GC/MS or by ion trap GC/MS. The method is based on the collection of whole air samples in SUMMA passivated stainless steel canisters. This method presents procedures for sampling into canisters to final pressures both above and below atmospheric pressure. Samples from scrubber vents employing aqueous acid should be passed through a cartridge containing granular sodium bicarbonate in order to avoid the possible accidental cocollection of acid mists which might subsequently destroy the target analytes. A diagram of the canister sampling system is presented as Exhibit 9.

2.3.1 Equipment - Sampling system should be constructed in such a way that only Teflon, stainless steel and the cartridge can come in contact with the sample.

2.3.1.1 Sodium Bicarbonate Cartridge - Needed if acid mists may be present in the volume of air to be sampled. A 1/2 " OD stainless steel or glass tube is packed with sodium bicarbonate 40/80 mesh for a distance of approximately 2 inches. The packing at both ends is held in place with glass wool. The cartridge is placed on the inlet side of the U-Tube. Swagelok fittings are recommended for adapting the cartridge to the diameter of the rest of the sampling system. A diagram is presented as Exhibit 8.

2.3.1.2 Canisters - Leak-free SUMMA passivated stainless steel pressure vessels. The volume selected will depend on application. Canisters should be equipped with needle valve and may be equipped with gauges, protective stands, valve guards, etc. depending upon the application. Scientific Instrumentation Specialists, Inc. PO Box 8941, Moscow Idaho 83843, (208) 882-3860.

2.3.1.3 Gauge - Stainless steel vacuum/pressure gauge capable of measuring both vacuum to 30 inches Hg and pressure to 30 psig. May be built into the sampling system or threaded to match the canisters. Matheson, PO Box 136, Morrow, GA 30200, Model 63-3704 or equivalent. Gauges should be tested clean and free from leaks.

2.3.1.4 Sampling Pump - For collection of time-integrated samples at positive pressure, equipped with adjustable flow controller, particulate matter filter, battery or line powered. Wind directional control, timer optional. XonTech Model 911A, 6862 Havenhurst Avenue, Van Nuys, CA 91406 (818) 787-7380 or equivalent.

2.3.1.5 Adjustable Critical Orifice Flow Controller - For collection of time-integrated samples at negative pressure, equipped with particulate matter filter and threaded to fit canister. Capable of being attached to sampling line. Model SC423-S-XF-T or equivalent Veriflow, 250 Canal Blvd, Richmond, CA 94804, (415) 235-9590.

2.3.1.6 Electronic Timer - Paragon Electric, 606 Parkway Blvd., PO Box 28, Twin Rivers, WI 54201, Model 7008-00 or equivalent.

2.3.1.7 Particulate Filter - 2 um sintered stainless steel in-line filter. Nupro, 4800 East 245th street, Willoughby, OH 44094, Model SS-2F-K4-2 or equivalent. May be incorporated into pump or critical orifice assembly.

2.3.1.8 Solenoid Valve - Magnelatch type, Skinner Magnelatch Valve, New Britain, CT, Model V5RAM49710 or equivalent. May be incorporated into pump assembly.

2.3.2 Reagents

2.3.2.1 Liquid Argon - Most economic grade available.

2.3.2.2 Glass Beads - Alltech 01.0 mm. or equivalent.

2.3.2.3 Tubing & Fittings - Stainless steel or heavy walled Teflon. Pretested for cleanliness.

2.3.3 Procedure - Grab sampling, ambient pressure. This is the simplest of the options available with canisters.

2.3.3.1 Bring precleaned, evacuated canister to sampling location. Record canister number in field notebook together with date, time, location and other relevant data.

2.3.3.2 Remove end cap.

2.3.3.3 Firmly attach vacuum/pressure gauge. Open needle valve. Verify vacuum is at least 25". If so record reading, close needle valve and remove vacuum/pressure gauge. If not, mark canister as a leaker and select another canister. Repeat vacuum check.

2.3.3.4 Hold canister at desired height/location or connect to purged sampling line if height/location cannot be conveniently reached. Open needle valve allowing air to rush in.

2.3.3.5 Close needle valve. Replace end cap.

2.3.3.6 Fill out Chain of Custody form. Check for agreement with field notebook.

2.3.4 Procedure - Grab sampling, positive pressure. This procedure differs from the ambient option in that liquid nitrogen is employed to partially liquefy the sample as it is collected. Upon warming to ambient temperature, a positive pressure is created. CAUTION DO NOT ALLOW CANISTER TO BECOME OVERPRESSURIZED. This method allows the container to be flushed and refilled in the field, if desired.

2.3.4.1 Bring precleaned, evacuated canister, liquid nitrogen and a "six pack" cooler chest to sampling location. Record canister number in field notebook together with date, time, location and other relevant data.

2.3.4.2 Remove end cap.

2.3.4.3 Firmly attach vacuum/pressure gauge. Open needle valve. Verify vacuum is at least 25". If so record reading, close needle valve and remove vacuum/pressure gauge. If not, mark canister as a leaker and select another canister. Repeat vacuum check.

2.3.4.4 Connect to purged sampling line which is at least 2' long or as required to reach the desired sampling height/location. Immerse canister in liquid nitrogen. As soon as the cryogen ceases to boil vigorously, open needle valve allowing air to rush in. Keep valve open 2-3 min BUT NO LONGER AS EXCESSIVE PRESSURE WILL OTHERWISE DEVELOP.

2.3.4.5 Close needle valve. Remove canister from liquid nitrogen. Allow to warm to ambient temperature (frost melts).

2.3.4.6 Attach vacuum/pressure gauge. Reopen needle valve. Record pressure. Bleed off excess if above 50 psig.

2.3.4.7 Close needle valve. Replace end cap.

2.3.4.8 Fill out Chain of Custody form. Check for agreement with field notebook.

2.3.5 Integrated Sampling, Subambient Pressure - This procedure describes a means by which pumpless, time integrated samples may be collected using a canister and a critical orifice flow controller.

2.3.5.1 In the laboratory, precalibrate the compensated critical orifice flow controller so that the rate of flow in will be sufficient to fill 2/3 to 3/4 the volume of the canister during the desired time interval. This flow should always be 2 mL/min or greater. Thus a 15 L canister is required for a 24-hr sample. Precalibration of the critical orifice can be conveniently verified by measuring the pressure drop over a 20-30 minute interval starting with a 1 L canister.

2.3.5.2 Bring canisters to the site attaching Teflon or stainless steel lines (after removing the end cap and verifying vacuum) as required to reach the desired height and/or location.

2.3.5.3 Open needle valve allowing air to leak in at the precalibrated rate. Record time, date, sampling location, canister number and other relevant data in field notebook. As sampling proceeds, it is possible to approximately verify the flow rate by closing the needle valve, temporarily disconnecting from the sampling lines, attaching the vacuum guage and comparing the vacuum with the expected vacuum. Adjustments, if necessary, can then be made in the flow controller. Reattachment after closing the needle valve and removing the vacuum guage allows sampling to be continued.

2.3.5.4 When the desired sampling period has elapsed, record the time in the field notebook, close the needle valve, detach the canister from the rest of the sampling system. Attach the vacuum guage, open the needle valve, record the final vacuum in the field notebook and on the Chain of Custody document. Reclose the needle valve, remove the vacuum guage and reattach the end cap.

2.3.5.5 Verify agreement between the Chain of Custody form and the field notebook.

2.3.6 Integrated Sampling, Positive Pressure - This procedure describes a means by which pumped, time integrated samples may be collected at positive pressure using a canister and a back pressure critical orifice flow controller. The sampling system may be purchased as a unit such as the XonTech 911A or assembled from the separate parts.

2.3.6.1 In the laboratory, precalibrate the flow controller so that the rate of flow in will be sufficient to fill 1.5 to twice the volume of the canister during the desired time interval. This flow should always be 5 mL/min or greater. Thus a 6 L canister is required for a 24-hr sample. Precalibration of the flow controller can be conveniently verified by measuring the pressure drop over a 20-30 minute interval starting with a 1 L canister.

2.3.6.2 Assemble the sampling lines as required to reach the desired height and/or location.

2.3.6.3 Attach the pumping system to the sampling lines, turn on the pump for a few minutes before attaching the canister in order to flush the sampling system. Shut off the pump, attach the canister after removing the end cap and verifying the initial vacuum.

2.3.6.4 Turn on the pump, open needle valve allowing air to be pumped in at the precalibrated rate. Record time, date, sampling location, canister number and other relevant data in field notebook. As sampling proceeds, it is possible to approximately verify the flow rate by closing the needle valve, temporarily disconnecting from the pump and sampling lines, attaching the vacuum gauge and comparing the actual vacuum with the expected vacuum. Adjustments, if necessary, can then be made in the flow controller. Reattachment after closing the needle valve and removing the vacuum gauge allows sampling to be continued.

2.3.6.5 When the desired sampling period has elapsed, record the time in the field notebook, close the needle valve, detach the canister from the rest of the sampling system. Shut off the pump or attach another canister. Attach the vacuum/pressure gauge, open the needle valve, record the final pressure in the field notebook and on the Chain of Custody document. Reclose the needle valve, remove the gauge and reattach the end cap.

2.3.6.6 Verify agreement between the Chain of Custody form and the field notebook.

2.4 Canister Cleaning - The system described is fundamentally identical to that presented by EPA in Compendium Method TO-14, Figure 7, (8). A schematic diagram is presented as Exhibit 10. Canisters must be cleaned between all uses by cycling between vacuum and humidified zero air with mild heating. Elaborate documentation that each canister has been cleaned together with appropriate verification are all components of the cleaning protocol.

2.4.1 Equipment Needed for Canister Cleaning - The following items, assembled as indicated in Exhibit 10 may be used to simultaneously clean several canisters.

2.4.1.1 Vacuum Pump - capable of evacuating up to 6 canisters to an absolute pressure of 0.05 mm Hg.

2.4.1.2 Manifold Setup - constructed of precleaned stainless steel tubing 1/4" OD with Swagelok tees, shutoff valves and connectors.

2.4.1.3 Vacuum Gauge - connected to the system, capable of measuring vacuum in the manifold to an absolute pressure of 0.05 mm Hg or less.

2.4.1.4 Cryogenic Traps - Two are required, one between the vacuum pump and the manifold to prevent pump oil volatiles from back diffusing and one between the zero air supply and the manifold. A U tube cooled with liquid argon will suffice. These tubes should be detachable so they may be removed for cleaning on a periodic basis.

2.4.1.5 Stainless Steel Pressure Regulators and Flow Controllers - to monitor zero air pressure and to regulate the flow of same to the canisters.

2.4.1.6 Heating Mantles, Oven or Heating Tape and Electrical Controller - for heating canisters to 90-110°C.

2.4.1.7 Helium Leak Detector - 21-150 Model or equivalent (Gow Mac Ins. Co.).

2.4.2 Reagents Needed for Canister Cleaning - The following reagents are needed for the operation of the canister cleaning system.

2.4.2.1 Zero Air - Cylinder, 5 "nines" or better. Even the highest grade still requires cryogenic trapping. Zero nitrogen may be substituted.

2.4.2.2 Liquid Argon - Cheapest available.

2.4.2.3 Organic Free Water - HPLC deionized water such as is used for blanks, standard preparation and dilutions for EPA 8240/8260/625.

2.4.3 Procedure for Canister Cleaning - All canisters must be clean and free of contaminants before sample collection. In practice it is best to segregate "source" canisters which are used for samples containing ppm levels and higher from "ambient" canisters which are used for samples containing ppb levels. Good record keeping demands that all canisters be uniquely numbered so that their dates of cleaning, shipment and sampling may be recorded by notebook/computer. Chromatograms documenting the success of cleaning by batch, at a minimum, should be on file with the cleaning records. For samples likely to be involved in litigation, it is recommended that chromatographic confirmation of cleaning be carried out for every canister. A copy of the EPA - recommended form presented as Exhibit 11 should accompany each canister as it is shipped.

2.4.3.1 Leak Check - All canisters must be leak checked prior to use. This is most conveniently accomplished by pressurizing to 30 psig with helium prior to cleaning and checking with a helium leak detector. Immersion in clean water, spraying seams with soapy water or pressurizing to 30 psig and rechecking the pressure after 24 hrs are other, less convenient, but effective methods for checking for leaks. This step is extremely important since canisters are shipped in an evacuated condition and, if leaking, will be continuously "sampling" the air as they are transported to the test site.

2.4.3.2 Assemble cleaning system as illustrated in Exhibit 10. Add cryogen to both traps. Preflush source canisters offline before connecting to the manifold. Connect "ambient" canisters to the manifold. Open both the shutoff valve and the canister needle valve for each canister being cleaned.

2.4.3.3 Start the vacuum pump. Close the shutoff valve at the vent and open the one to the vacuum pump. Evacuate to 0.05 mm Hg and hold at least one hour. Heat to about 100°C during this time.

2.4.3.4 Close the canister shutoff valve and the canister needle valve. Allow the canister to cool, place a septum end cap on the canister. Open the needle valve and inject about 0.5 mL organic free water. Close the needle valve, reattach to the cleaning system, admit zero air to about 30 psig.

2.4.3.5 Close the connection to the zero air supply, open vent until pressure reaches ambient. Close the vent. Repeat evacuation, heating and flushing twice more so that each set of canisters receives a total of three evacuation/heating/pressurization cycles.

2.4.3.6 Following cleaning, verify batch cleanliness by filling one canister to 30 psig with cryogenically cleaned air. Analyze to verify that no target compounds are present above 0.2 ppbv. In the case of ethylene and propylene oxides, this requirement is lowered to "none detected" with a detection limit of 5 pptv. If litigation is likely, all canisters should be preanalyzed before every use.

2.4.3.7 If verification of cleanliness is not achieved, reclean entire batch. Canisters are evacuated to 0.05 mm Hg, endcapped, shipped and stored under vacuum. It is helpful to place a "date cleaned" identification tag on each canister immediately after cleaning in order to prevent confusion when large numbers of canisters are being received, analyzed, cleaned, stored and shipped.

2.5 Transfer from Canisters to the Analytical System - The system diagrammed in Exhibit 12 and described in the paragraphs which follow employs a vacuum reservoir to draw a measured volume of air through a cryogenic U-Tube collector much like the ones described earlier in subsection 2.2.1.2. Once the desired volume of air has been withdrawn from the canister, valves are rotated and hot water is used to drive the trapped volatile organics to a second capillary focussing loop which is part of the analytical system. Again, Nafion may not be used to remove water as this acidic polymer has been shown to effectively destroy ethylene oxide. Ambient samples typically do not require any other mechanism to remove water as most water is left behind in the U-Tube and never reaches the analytical system. Wet samples, however, may require the use of the two dimensional chromatographic system described in subsection 2.2.4.1.

2.5.1 Equipment - Assembled as shown in Exhibit 12. The vacuum reservoir draws sample through transfer lines made entirely of stainless steel tubing, chromatographic grade. Heavy walled Teflon tubing, 1/4" OD may be substituted but must be discarded as soon as it becomes contaminated as it is not as easy to clean as stainless steel. All fitting and valve surfaces are constructed of stainless steel or Teflon.

2.5.1.1 Vacuum Pump - Capable of evacuating the reservoir to an absolute pressure of 0.05 mm Hg.

2.5.1.2 Vacuum Reservoir - Volume should be at least twice as large as the largest sample volume to be transferred.

2.5.1.3 Vacuum Gauge - Accurate to 0.1 inch Hg. Since gaseous standards are drawn through the reservoir, it is not strictly necessary to know its volume in order to arrive at a correct value for the concentration. Knowing the reservoir volume, however, is necessary if one wishes to know the sample size. Marshall/Town Model 92021 or equivalent.

2.5.1.4 U-Tubes - Constructed of heavy walled borosilicate glass, aluminum or nickel and partially filled with silanized glass beads 1 mm in diameter. About 1/3 to 1/4 as large as shown in Exhibit 6 is a good size. Two are needed.

2.5.1.5 Six-Port Chromatographic Valve - VICI-C6T Model or equivalent.

2.5.1.6 Eight-Port Chromatographic Valve - VICI-C8T Model or equivalent.

2.5.1.7 Stainless Steel Vee - In line between canister and U-Tube. One end sealed with gas chromatographic septum to permit introduction of small sample volumes using a gas tight syringe.

2.5.1.8 Hair Dryer - Standard. Used to "chase" less volatile sample components into the analytical system in order to prevent buildup in cold spots along the transfer line.

2.5.1.9 Wide Mouth Stainless Steel Thermos - One for each U-Tube. One for hot water. The latter may be plastic as the hot water will not make it brittle. Stainless steel, however, is ABSOLUTELY required for the liquid argon in order to avoid danger from implosion. NEVER USE GLASS.

2.5.2 Reagents

2.5.2.1 Liquid Argon - Most economical grade available.

2.5.2.2 Hot Water - 90-95C

2.5.2.3 Glass Beads - Silanized, 1.0 mm diameter Alltech or equivalent.

2.5.2.4 Internal Standard - Gaseous bromofluorobenzene (BFB), pressurized to several hundred psig at 500-1,000 ppbv. Since the same amount is introduced to every sample, the exact concentration is unimportant. Using BFB allows instrument performance to be verified at any time. A second, earlier eluting internal standard such as fluorobenzene may be used as well.

2.5.3 Procedure

2.5.3.1 Assemble apparatus as shown in Exhibit 12.

2.5.3.2 Turn on vacuum pump. Evacuate reservoir while it is isolated from the rest of the system. Fill trap with cyrogen. Immerse U-Tube.

2.5.3.3 Verify needle valve is closed. Remove end cap from canister. Attach vacuum/pressure gauge. Open needle valve. Record vacuum or pressure. Record in sample injection record book. Compare with chain of Custody document and/or canister record form. Verify that received pressure/vacuum is compatible with what was recorded in field allowing for changes in altitude and temperature. If different, indicate "compromised sample" on reports and injection records. If still under shipped vacuum, indicate "invalid sample" and call client immediately. DO NOT RUN INVALID SAMPLES.

2.5.3.4 IF COLLECTED OR RECEIVED AT LESS THAN 5 PSIG, add sufficient cryogenically cleaned air to pressurize to at least 5 psig but not more than 30 psig. Record new pressure. Dilution factor must be taken into account in calculating final results. CAUTION dilution factor is calculated from absolute pressures. Both absolute pressures must be in the same units.

2.5.3.5 Close needle valve. Attach canister to the transfer system. Isolate the vacuum reservoir from the pump. Record the vacuum. Verify U-Tube connected to 8-port valve is immersed in cryogen.

2.5.3.6 Connect vacuum reservoir to canister. Open needle valve allowing sample to be drawn through U-Tube thereby producing a change in the vacuum as noted on the vacuum guage. When the desired change has occurred, switch the 8-port valve so that the canister is no longer connected to the vacuum reservoir. Close the canister needle valve and record vacuum change on injection record and on the analytical system's file header. Note dilution factors, if any, in both places.

2.5.3.7 Switch 8-port valve from "load" position to "inject" position so that carrier gas now flows through the first U-Tube to the second. Replace argon in FIRST U-Tube with hot water. Use the hair dryer to "chase" sample volatiles to second U-Tube for internal standard addition.

2.5.3.8 Again switch the 8-port valve so that the gaseous internal standard flows through the internal standard loop (recommended loop size is about 1.0 mL). Flush with about 10 mL, shut off internal standard at tank, switch loop so that carrier gas will then sweep the internal standard to the second U-Tube.

2.5.3.9 Move thermos of liquid argon originally used for first U-Tube to a position between the second U-Tube and the GC oven. Withdraw enough of the analytical column from the oven so that a loop can be forced into the thermos. This will serve to cryogenically focus the sample components on the analytical column once the sample transfer has been completed from the second U-Tube.

2.5.3.10 To complete transfer of the sample and the internal standard to the analytical system, replace the argon with hot water while switching the 6-port valve to "inject". This step will allow the carrier gas to sweep the volatile sample components onto the focussing loop.

2.5.3.11 IF THE SAMPLE IS EXPECTED TO CONTAIN HIGH LEVELS OF TARGET COMPOUNDS, connect a source of cryogenically cleaned zero air to the position normally occupied by the canister and draw a little into the vacuum reservoir to flush the line. Inject 1-5000 uL of sample through the septum, making sure that the end of the needle extends past the juncture of the vee. Using the vacuum reservoir, draw about 500 mL of zero air to sweep the mini sample through the first U-Tube. Proceed with steps 2.5.3.7 through 2.5.3.10.

2.6 Stability of Ethylene Oxide in Canisters

2.6.1 Earlier Studies - A study performed by the Radian Corporation for EPA and reported in 1988 (3) compared the stability of ethylene oxide samples in three container types. In the Radian study, sample concentrations ranged from several hundred to just over 1,000 ppmv. Such concentrations are typical of those encountered in scrubber efficiency studies. Syringes, Tedlar Bags and Vacu-Samplers were compared. According to the Radian study, all three container types exhibited losses when immediate results were compared with results taken several days later. These results, taken from the Radian report, are summarized below.

Gas-Tight Syringe - after 4-5 days, 20% loss.

Tedlar Bags - w. 12/88 after 48 hr, stable.
- after 5-6 days, 30% loss.
- w. pure EO after 4 days, stable.
- after 8 days, 20% loss.
- after 12 days, 33% loss.

Vacu-Sampler - after 4 days, 15% loss.

It should be noted that, for example, a 30% loss would imply that losses at lower levels would be unacceptably higher.

In addition to the above, there was a general conclusion that percent losses were greater at lower concentrations. Since the Radian study had already addressed high concentration stabilities, CCAS decided to address low concentration stabilities. General studies performed for EPA by Karen D. Oliver, Joachim D. Pleil and William McClenny in 1985 using SUMMA electropolished canisters (10), (11), indicated that virtually all volatile organics tested were stable at the 1-5 ppbv level for 30 days. These studies, however, did not include ethylene oxide or any polar compounds. Accordingly, CCAS stability studies have focussed on SUMMA electropolished canisters.

2.6.2 Reasons for Conducting Canister Stability Studies - As an alternative to onsite analysis with a portable GC/PID, grab samples could, in principle, be collected and transported to the laboratory for subsequent analysis - providing acceptable stability could be demonstrated. This alternative offers the following advantages:

2.6.2.1 Large number of samples can be collected.

2.6.2.2 Time intervals between collections which are shorter than time required for onsite analysis may be employed.

2.6.2.3 Laboratory analyses from canisters can be repeated thereby permitting precision to be established with real samples rather than with calibration standards.

2.6.2.4 Aborted analyses can be repeated thereby providing a higher percent completion.

2.6.2.5 Canister samples can be sent to other laboratories for confirmation of results upon which important decisions will be made.

2.6.3 CCAS Stability Studies Conducted in the Winter of 1989/1990 - An electropolished stainless steel canister was pressurized to about 30 psig with a certified reference standard (Scott Specialty Gases) containing ethylene oxide at a concentration of 121 ppbv. Since the certified reference standard had shown no apparent degradation in its own aluminum cylinder at 2000 psig, a comparative analysis of the standard from the cylinder vs the same standard after storage in a canister at more normal sample pressures would and did provide an effective demonstration of stability as shown below.

2.6.3.1 After 1 day - 99%

2.6.3.2 After 5 days - 96%

2.6.3.3 After 12 days - 103%

2.6.3.4 After 22 days - 86%

A subsequent intercalibration study performed in conjunction with the sampling of urban ambient air and involving the ARB lab staff indicated that the 121 ppbv standard HAD degraded significantly over the first 10 months. This degradation was subsequently confirmed upon receipt of a freshly prepared cylinder. Although this degradation, which was possibly as large as threefold, had occurred over 10 months rather than 22 days and in any case would have amounted to only another 7%.

2.6.4 CCAS Stability Studies Conducted in the Winter of 1991 - Three 15 L electropolished stainless steel canisters were pressurized to about 30 psig with a diluted certified reference standard to achieve final concentrations of approximately 10 ppbv, 90 ppbv and 1000 ppbv respectively. These were sampled at intervals over a period of one month. The results of this study are presented in Table 1. Fifteen liter canisters were used for this study so that serial withdrawals would not represent a significant percentage of the total sample in the container. Stability was confirmed only at the 1000 ppbv level while half of the original concentration disappeared in just 2 days at the 90 ppbv level. The latter result is somewhat different from that of the study performed in the Winter of 1989/1990. This difference may be due to canister-to-canister variability but nevertheless suggest that results from canister samples which are much below 1000 ppbv should be interpreted with caution, particularly if not analyzed within 48 hours of collection. All of the ethylene oxide present in the 10 ppbv sample disappeared immediately.

2.6.5 Recent publications describing the stability of polar organics in stainless steel canisters such as the one by Bruce Pate, R.K.M. Jayanty, Max R. Peterson and G.F. Evans (11) indicate that the presence of water vapor, expected in sterilization exhausts may stabilize concentrations. The CCAS studies, however, were conducted in dry zero air.

3.0 Development of Test Methods for Sterilizer Gas Vent Streams: Photoionization detector - Samples may be directly injected by pumping a small volume of air through an injection loop (0.1 - 1.0 mL in volume) or collected by either the U-Tube method or in electropolished canisters. Since larger volumes may be subsequently injected if collection is performed by U-Tube, this method of sampling is better reserved for ambient samples. NIOSH method 3702, published in 1987 (5), describes a method for collecting workplace air samples in Tedlar bags or gastight syringes and analyzing them by portable photoionization detector. This method is very similar to CARB Method 431. Appendix B of EPA Method TO-14 also provides a detailed description of the use of a portable GC/PID for the determination of volatile organics in air. As described, these methods are well suited for use with samples having concentrations ranging from 10-100 ppbv to 1000 ppmv. If collected samples are brought to the laboratory, levels as low as 5 pptv may be analyzed. Copies of these methods are appended for the reviewer's convenience.

3.1 Equipment

3.1.1 Portable PID/GC - Photovac 10S50 or equivalent. The detector should be equipped with a lamp having an energy at or above 10.6 ev.

3.1.2 Laboratory PID/GC - Hewlett-Packard, Model 5890. The detector should be equipped with a lamp having an energy at or above 10.6 ev. Freon 12, commonly used as a diluant in ethylene oxide sterilization does not produce a response with the 10.6 ev lamp as its ionization potential at 12.3 ev is too far above that of the lamp to allow a signal to develop.

3.1.3 Chromatographic Columns - 1.2 m X 3 mm OD PTFE, packed with Caropak BHT 40/100 mesh for portable system or 30M by 0.25 mm DB5 with 0.1 u film, JW Scientific for laboratory system.

3.1.4 Sample Collection Equipment - as described in earlier sections.

3.1.5 Acid Demister Cartridge - Sodium bicarbonate as described in earlier sections. Needed only for acid scrubbers.

3.1.6 Pump - Portable 12V DC Teflon diaphragm sampling pump.

3.2 Reagents

3.2.1 Liquid Argon - Cheapest grade available, not needed if sampling loop method used for sample transfer.

3.2.2 Ethylene Oxide - Gaseous standards, Scott Specialty Gases or equivalent. Recommend master standard at 1-100 ppmv or higher with lower level standards prepared by dilution on a daily basis.

3.2.3 Bags, syringes, canisters, U-Tubes - as needed for sample collection.

3.3 Procedure, portable GC method - Samples may be introduced from canisters or bags using the built-in sampling loop or by means of a gastight syringe using the conventional injection port. The GC may be connected in-line through a short length of stainless steel or heavy walled Teflon tubing. The use of an in-line bicarbonate demister is recommended if acid scrubbing is part of the control process. A diagram of this sample

system, loop method, is presented as Exhibit 15. The details of the valve switchings within the analytical system are presented as Exhibit 16. The protocol which follows is for the portable system. A separate subsection (3.4) is used to describe the laboratory GC/PID method.

3.3.1 Establish calibration using standard mixtures at levels which bracket the expected concentration ranges at the facility being tested. Following acceptable calibration or subsequent verification of calibration, verify an acceptable blank. The analytical system is then ready for use with real samples.

3.3.2 Pass air from the EO vent through a T-connection attached to the sample inlet of the gas chromatograph. The Photovac 10S50 is equipped with an internal pump and valve system which automatically draws a fixed volume of air into the sample loop (event 1,4 - Exhibit 16).

3.3.3 After drawing approximately 10 loop volumes of sample through the loop, the valves are automatically switched so that the volume of sample contained in the loop is injected onto the precolumn (event 3 - Exhibit 16).

3.3.4 The instrument is programmed to automatically switch the valves again just after the target compounds have cleared the precolumn (about 30 seconds) and entered the analytical column so that later eluting compounds can be backflushed from the precolumn while the separation of the target compounds from other, more closely related compounds is being accomplished on the analytical column (backflush configuration - Exhibit 16).

3.3.5 The full analytical cycle requires 3-4 minutes. This imposes a limitation on the temporal variations in concentration which can be observed using this method. If, for example, one wished to observe concentration changes over a shorter time interval, it would be necessary to collect and hold samples for subsequent analysis. Multiple portable GCs could be used to circumvent this difficulty.

3.3.6 The analytical system can be programmed to run standards automatically. These should be prepared in the laboratory immediately prior to sampling and brought to the field in SUMMA electropolished canisters. Levels of 10 ppmv and 100 ppmv are recommended. Lower level field standards are best prepared by dilution of the 10 ppmv standard if needed, in the field. The following protocol is recommended:

3.3.6.1 Flush a clean 1-3L Tedlar bag 2-4 times with zero air. Leave in partially inflated condition. Label "1 ppmv field standard".

3.3.6.2 Using a gastight syringe, and with flushing, withdraw 100-300 mL from the 10 ppmv standard. Inject into bag through septum with flushing.

3.3.6.3 Squeeze partially inflated bag containing the added EO in order to thoroughly mix the contents.

3.3.6.4 Repeat, if necessary, using only 10-30 mL of the 10 ppmv standard to create a 100 ppbv standard.

3.3.7 Measurement Strategy - Good record keeping is an essential component of any measurement and sampling strategy. A field notebook should be kept in which all pertinent data about the facility and each sampling increment should be recorded in waterproof ink. Pages should be numbered, dated and signed. Corrections, if necessary, should be made by lining out and initialing the incorrect items and replacing them with correct data, referring to a fresh page as required. The use of correction fluid and/or erasures is absolutely prohibited. If permitted by the facilities owner, Polaroid snapshots of the sampling points, signed and dated with a referral to the field notebook are recommended. Sufficient room should be left at the beginning for a complete table of contents.

3.3.7.1 Samples of vent gases should be analyzed for ethylene oxide throughout the entire exhaust cycle of the sterilization chamber while it is run with a typical load. Likewise, tests on control devices for aerator exhaust streams should be made for a period of at least an hour, begun within 15 minutes of placement of a typical load.

3.3.7.2 Sterilizer systems should be checked to validate the absence of leaks using, at a minimum, a photoionization device with a lamp of 10.6-11.2 ev. California's Proposed Ethylene Oxide Control Measure for Sterilizers and Aerators requires that such systems be leak free. In this way, emissions control efficiencies can be calculated by comparing EO input to outlet without actually measuring inlet. This strategy presumes that the EO consumed during sterilization and/or retained by the sterilized material is negligible relative to the input. Otherwise, the inlet to the control device must also be analyzed.

3.3.7.3 Aerator systems should be sampled at both the inlet and the outlet since the EO input would not generally be known. Mass flow measurements for both aerator and sterilizer control systems need be measured only at the outlet since both are required to be leak-free. Using the data for the instantaneous mass flow rates and the measured ethylene oxide concentrations, the mass flow rate of EO can be calculated. The total amount of EO emitted from the vent as well as the overall destruction efficiency can then be determined from these calculations.

3.3.7.4 If expected EO concentrations in vent gases are above 20 ppmv, it would be preferable to collect grab samples in electropolished stainless steel canisters for subsequent analysis in the laboratory. This would increase sampling flexibility since true grabs or short-term integrated samples would provide continuous or near continuous sampling while on-line GC/PID sampling and analyses would unavoidably incorporate a delay time of 3-4 minutes between each sampling event.

3.3.7.5 In order to confirm that a sterilizer control device is removing 99.9% of the EO from the exhaust stream, it is recommended that sampling be continued through at least four purge cycles. A purge cycle is defined as that portion of the sterilizer venting process in which gaseous material is leaving the sterilization chamber, driven either by prior pressurization of the chamber and/or application of vacuum. This recommendation stems from the fact that typical purge cycles remove only about 90% of the gas from the chamber. Thus even if ALL of the ethylene oxide were to be removed from the exhaust stream during the first cycle, the proven efficiency would only be 10%.

Similarly the maximum proven efficiency after two and three cycles would only be 99% and 99.9% respectively. Since SOME ethylene oxide would undoubtedly be found in the post-control samples, it would require at least 4 cycles to demonstrate 99.9% efficiency. The writers believe that, at present, it would be unwise to measure only the first cycle and then presume that destruction efficiency would be independent of concentration.

3.3.7.7 Sampling should be started as soon as the sterilizer evacuation cycle is begun and should be continued at maximum frequency until the evacuation cycle is complete. The evacuation cycle is defined as that portion of the purging cycle during which a vacuum is applied. If prior pressurization has not preceded this step, the evacuation cycle is the same as the purge cycle. The exact frequency will depend upon the operating characteristics of the facility itself. Shorter cycles between sample collections are recommended in order to avoid the possibility that a "slug" emission might be missed. For this reason, canister 3-5 minute quasi-integrated samples might do a better job than pure on-line grabs.

3.4 Assemble transfer apparatus according to Exhibit 7 (U-Tube) or Exhibit 12 (canister) depending on how samples were collected. Verify that the detector temperature is no higher than 120 C and that the energy of the lamp is no lower than 10.6 ev.

3.4.1 Establish calibration using standard mixtures at levels which bracket the expected concentration ranges at the facility being tested. Following acceptable calibration or subsequent verification of calibration, verify an acceptable blank. The analytical system is then ready for use with real samples.

3.4.2 Pass air from the EO vent through an appropriate preflushed connector attached to the sample inlet of the sampling container. The use of a bicarbonate acid demister is recommended when sampling acid scrubber devices. Refer to Section 2 for sample collection descriptions.

3.4.3 Transfer of collected samples to the analytical system employs two-dimensional gas chromatography to selectively separate volatile organic constituents from cocollected water as well as from the less volatile sample components. Refer to Exhibit 7 and subsection 2.2.4.

3.4.4 The first 10-15cm of the precolumn is maintained at 60 C while the analytical column may be held at 30 C for 3 min before being programmed to 100 C at 5 /min in order to clear heavier sample components from the system. The flow of carrier gas through the precolumn should be about 30 mL/min. The flow of carrier gas through the analytical system should be 1 mL/min.

3.4.5 As the precolumn effluent containing the ethylene oxide exits the precolumn, it passes through a 6-port capillary switching valve. Following a brief venting period, the valve is switched thereby directing the flow from the precolumn onto a section of uncoated fused silica capillary column (0.32 mm ID) which passes through a Tekmar 100 cryogenic focussing capillary interface maintained at -150 C. thereby trapping the EO.

3.4.6 After 8-10 minutes, the capillary valve is switched back to its original position. Subsequent heating of the capillary interface contained within the Tekmar 1000 serves to transfer the target compounds to the analytical system. During this same time period the water and higher boiling organics slowly elute from the precolumn and are vented to the atmosphere.

3.4.7 The operating conditions of the gas chromatograph should be tested using gaseous acetaldehyde and gaseous ethylene oxide. These two compounds will both produce signals in the PID and are likely to be present in most samples. Conditions should therefore be adjusted to provide a separation of at least 10 seconds between these two compounds. A program which meets this objective for a 25 m by 0.32 methyl silicone column with a carrier gas flow of 1 mL/min is provided below:

Initial hold at 30 C for 3 minutes

Program at 5 C/min to 100 C

4.0 Development of the Test Method: Ion Trap GC/MS - Due to differences in construction of the source, the Ion Trap mass spectrometer is inherently more sensitive than conventional quadrupole mass spectrometers. Like conventional mass spectrometers, the Ion Trap may produce an initially charged molecular ion or fragment ion by electron impact or chemical ionization. Due to its ability to operate at higher source pressures, even the electron impact ionization is generally more gentle than is the case with quadrupole mass spectrometry. Consequently Ion Trap fragmentation patterns often exhibit stronger molecular ions and less fragmentation than does quadrupole mass spectrometry. Since carbon dioxide has the same molecular weight as ethylene oxide, the Ion Trap was operated in the chemical ionization mode. Under these conditions, EO provides a strong M+1 ion at m/e 45 which is not duplicated by carbon dioxide. These conditions were found to be the most sensitive and were therefore used throughout the investigation.

4.1 Equipment

4.1.1 Mass Spectrometer - Finnigan MAT Ion Trap Detector (ITD) or equivalent. Operated in the chemical ionization mode (CI) using methane as the reactant gas.

4.1.2 Gas Chromatograph - Hewlett-Packard, Model 5890 or equivalent.

4.1.3 Chromatographic Column - 30M by 0.25 mm DB5 with 0.1 u film, JW Scientific or equivalent.

4.1.4 Sample Collection Equipment - As described in earlier sections.

4.1.5 Two-dimensional sample transfer system - Equipped with a source of cryogenically purified nitrogen or helium, a 4-port valve, a thermos for cryogen, a thermos for hot water and a glass precolumn 1.2m by 4 mm ID packed with 15% BCEF on 60/80 mesh Gas Chrom Q II. Assembled as shown in Exhibit 7.

4.1.6 Tekmar Model 1000 cryogenic focussing capillary interface or equivalent containing a short length of 0.32 mm ID uncoated capillary tubing.

4.2 Reagents

4.2.1 Liquid Argon - Recommended cryogen for transfer trap, most economic grade available. CAUTION: DO NOT SUBSTITUTE WITH LIQUID NITROGEN OR LIQUID OXYGEN.

4.2.2 Glass Beads - For use in first transfer U-Tube. Also used in collecting U-Tubes. Alltech, 1. mm, silanized.

4.2.3 Teflon Tubing - Alltech, heavy walled 1/4" OD, capable of accepting Swagelok connectors or equivalent. It is advisable to batch test for cleanliness before use.

4.2.4 Liquid Nitrogen - Recommended cryogen for Tekmar 1000 and for cooling GC oven between runs.

4.3 Procedure - The first step in the Ion Trap analysis begins with the transfer of the sample to the analytical system. Although these have been presented earlier, the U-Tube method is included here for the sake of completeness. This combination thus combines the most sensitive sample collection method with the most sensitive analytical method allowing detection limits as low as 2-5 pptv to be reached. The use of other sample collection methods and transfer systems in combination with the Ion Trap is, of course, possible.

4.3.1 The transfer system shown in Exhibit 7 employs two-dimensional gas chromatography to selectively remove the water which is incidentally cocollected with the samples. This technique may be used with either U-Tubes or canisters. The polar precolumn significantly retards water vapor while permitting even a relatively polar compound like ethylene oxide to elute first.

4.3.2 The U-Tube, still immersed in liquid argon, is connected to a 4-port switching valve while being flushed with cryogenically purified carrier gas. This step effectively prevents the intrusion of laboratory air.

4.3.3 Upon removal of cryogen, the 4-port valve is switched so that carrier gas now passes through the U-Tube. The U-Tube is immediately immersed in hot water (95-100 C) causing rapid desorption of the sample while sweeping it into the injection port.

4.3.4 The first 10-15 cm of the precolumn is maintained at 60 C while the remainder of the precolumn may be held at 60 C or programmed to a higher temperature to encourage the elution of higher boiling sample components. The flow of carrier gas through the precolumn should be about 30 mL/min.

4.3.5 As the effluent containing the ethylene oxide and other sample components having similar chromatographic properties exits the precolumn, it passes through a 6-port capillary switching valve. Following a brief venting period, the valve is switched thereby directing the flow from the precolumn onto a section of uncoated fused silica capillary column (0.32 mm ID) which passes through a Tekmar Model 1000 cryogenic focussing interface maintained at -150 C. This step serves to trap the target analytes.

4.3.6 After 8-10 minutes, the capillary valve is switched back to its original position. Subsequent heating of the capillary interface contained within the Tekmar 1000 transfers the target analytes to the analytical system. During this time, the water and higher boiling sample components elute from the precolumn and are vented to the atmosphere.

4.3.7 Verify that the sample identity, size, log number and description on the GC/MS file header match those on the injection record and on the Chain of Custody document. Start the GC/MS run.

4.3.8 The analytical column is then held at 30 C for 3 minutes after which the temperature is raised to 100 C at 5 /min in order to clear higher boiling components from the system. The Ion Trap mass spectrometer is operated in the full scan mode. The mass range scanned is m/z 35-100. Data are acquired at 1 second/scan. Chromatographic conditions should be verified to be such that acetaldehyde is separated from ethylene oxide by at least 10 seconds. Carrier gas flow through the analytical column should be 1 mL/min.

4.3.9 Establish calibration using standard mixtures at levels which bracket the expected concentration ranges of the samples being tested. Following acceptable calibration or subsequent verification of calibration, verify an acceptable blank. The analytical system is then ready for use with real samples.

5.0 Development of the Test Method: Quadrupole GC/MS - Quadrupole GC/MS systems are readily available and, while less sensitive than the Ion Trap, have the advantage of being more generally compatible with recognized data bases such as the NTIS/EPA Mass Spectral Data Base. This, however, is not a major shortcoming of the method previously described since this project is only concerned with the quantitative identification of ethylene oxide and propylene oxide. These are available as standards and would not require foreknowledge of their fragmentation patterns.

5.1 Equipment

5.1.1 Mass Spectrometer - Hewlett-Packard Mass Selective Detector (MSD), Model 5970 or equivalent, equipped with computer and appropriate software. This system may be operated in either the full scan mode or the selective ion mode. If the former is used, a mass range from m/z 25 to m/z 100 is recommended. The use of two ions, m/z 44 and m/z 29 are recommended if the selective ion mode is used.

5.1.2 Gas Chromatograph - Hewlett-Packard, Model 5890 or equivalent, capable of subambient temperature programming.

5.1.3 Chromatographic Column - Capillary, fused silica, 30m by 0.25 mm DB5 with 0.1 u film, JW Scientific or equivalent.

5.1.4 Vacuum Reservoir Sample Transfer System - Assembled as shown in Exhibit 12. While other sample transfer systems may be substituted, this system is included as part of the needed equipment for the sake of completeness.

5.1.4.1 Vacuum Pump - Capable of evacuating the reservoir to an absolute pressure of 0.05 mm Hg.

5.1.4.2 Vacuum Reservoir - Volume should be at least twice as large as the largest sample volume to be transferred. Since gaseous standards are drawn through the reservoir, it is not strictly necessary to know its volume in order to arrive at the correct values for analyte concentrations. Knowing the reservoir volume, however, is necessary if one wishes to know the sample size.

5.1.4.3 Vacuum Gauge - Accurate to 0.1 inch Hg. Marshall/Town Model 92021 or equivalent.

5.1.4.4 U-Tubes - Constructed of heavy walled borosilicate glass, aluminum or nickel and partially filled with silanized glass beads 1 mm in diameter. The remaining volume should be packed with silanized, cleaned, glass wool. About 1/3 to 1/4 the size shown in Exhibit 6. Two are needed.

5.1.4.5 Six-Port Chromatographic Valve - VIVI-C6T or equivalent

5.1.4.6 Eight-Port Chromatographic Valve - VIVI-C8T or equivalent

5.1.4.7 Stainless Steel Vee - In line between canister and U-Tube. One end sealed with gas chromatographic septum to permit the introduction of small sample volumes using a gas tight syringe.

5.1.4.8 Hair Dryer - Standard. Used to "chase" less volatile sample components into the analytical system in order to avoid buildup in cold spots along the transfer line.

5.1.4.9 Wide mouth Stainless Steel Thermos - One for each U-Tube plus one for hot water. The latter may be plastic as the hot water will not make it brittle. Stainless steel, however, is ABSOLUTELY required for the liquid argon in order to avoid danger from implosion. NEVER USE GLASS.

5.1.5 Canisters - Leak-free SUMMA passivated stainless steel pressure/vacuum vessels. The volume selected will depend upon the application. Canisters should be equipped with a needle valve and a Swagelok type end cap. Canisters may also be equipped with gauges, flow controllers, protective stands, valve guards, etc. depending upon the application. Scientific Instrumentation Specialists, Inc., PO Box 8941, Moscow, Idaho 83843, (208) 882-3860. Sample containers other than canisters may be used with this method. The canister method has been included with this method description only for the sake of completeness.

5.1.6 Gauge - Stainless steel vacuum/pressure gauge capable of measuring both vacuum to 30 inches Hg and pressure to 30 psig. May be built into the sampling system or threaded to match the canisters. Matheson, PO Box 136, Morrow, Georgia 30200, Model 63-3704 or equivalent. Gauges should be tested and found to be clean and free from leaks.

5.2 Reagents

5.2.1 Liquid Argon - Most economical grade available.

5.2.2 Glass Beads - Silanized, Alltech 1. mm or equivalent.

5.2.3 Tubing and Fittings - Stainless steel or heavy walled Teflon. Pretested for cleanliness.

5.2.4 Hot Water - 90-95 C

5.2.5 Internal Standard - Gaseous bromofluorobenzene (BFB), pressurized to several hundred psig at 500-1,000 ppbv. Since the same amount is introduced into every sample, the exact concentration is unimportant. Using BFB and adjusting the scan range to include all of the molecular ions allows instrument performance to be evaluated at any time. A second, earlier eluting internal standard such as fluorobenzene may be used as well.

5.3 Procedure

5.3.1 Assemble the sample transfer system as shown in Exhibit 12.

5.3.2 Turn on the vacuum pump. Evacuate the reservoir while it is isolated from the rest of the system. Fill the U-Tube trap with liquid argon. Immerse U-Tube.

5.3.3 Verify instrument performance by introducing the gaseous BFB through the transfer system. A spectrum must be produced which meets the EPA established performance criteria listed in Table 1. If this is not possible, retune and retry. If still unsuccessful, it may be necessary to clean the source or repair the instrument. These criteria must be met and documented at least once per 12 hours of operation.

5.3.4 Establish calibration using standard mixtures at levels which bracket the expected concentration ranges of the samples being tested. Following acceptable calibration or subsequent verification of calibration, verify an acceptable blank. The analytical system is then ready for use with real samples.

5.3.5 Verify needle valve on canister is closed. Remove end cap from canister. Attach vacuum/pressure guage. Open needle valve. Record vacuum or pressure in sample injection record book. Compare with Chain of Custody document and/or canister record form. Verify that the received pressure/vacuum is compatible with that which was recorded in the field allowing for changes in altitude and temperature. If different, indicate "compromised sample" on reports and injection records. If still under "as shipped" vacuum and not a travel blank, indicate "invalid sample" and call the client immediately. DO NOT RUN INVALID SAMPLES.

5.3.6 IF SAMPLES RECEIVED AT LESS THAN 5 PSIG, add sufficient cryogenically cleaned helium to pressurize to at least 5 psig but not more than 30 psig. Record new pressure. The dilution factor must be taken into account in calculating final results. CAUTION: the dilution factor is calculated from absolute pressures. Both absolute pressures must be in the same units.

5.3.7 Close the needle valve. Attach the canister to the transfer system. Isolate the vacuum reservoir from the pump. Record the vacuum. Verify that both U-Tubes are immersed in liquid argon.

5.3.8 Connect the vacuum reservoir to the canister by rotating the 8-port valve to the "load" position. Open the needle valve on the canister allowing the sample to be drawn through the U-tube thereby producing a change in the vacuum as noted on the vacuum guage. When the desired change has occurred, switch the 8-port valve so that the canister is no longer connected to the vacuum reservoir. Close the canister needle valve and record the vacuum change on the injection record and on the analytical system file header. Note dilution factors, if any, in both places.

5.3.9 Switch the 8-port valve from the "load" position to the "inject" position causing carrier gas to flow through the first U-tube to the second which is now immersed in liquid argon. Replace the liquid argon thermos under the first U-tube with a second thermos filled with hot water. Use the hair dryer to "chase" sample volatiles to the second U-tube for internal standard addition.

5.3.10 Again switch the 8-port valve so that the gaseous internal standard flows through the internal standard loop (recommended loop size 1.0 mL). Flush with about 10 mL, shut off internal standard at tank, switch valve so that carrier gas will then sweep the internal standard to the second U-tube.

5.3.11 Move the Dewar flask of liquid argon originally used for the first U-tube to a position between the second U-tube and the GC oven. Withdraw enough of the analytical column from the oven so that a loop can be forced into the thermos. This will serve to cryogenically focus the sample components on the analytical column once the sample transfer has been completed from the second U-tube.

5.3.12 Complete the transfer of the sample and the internal standard to the analytical system by replacing the liquid argon under the second U-tube with hot water while switching the 6-port valve to "inject". This step allows the carrier gas to sweep the volatile sample components plus the internal standard onto the focussing loop.

5.3.13 IF THE SAMPLE IS EXPECTED TO CONTAIN HIGH LEVELS of target compounds such as would be the case for source gas test samples, connect a source of cryogenically cleaned zero air to the position normally occupied by the canister and draw a little into the vacuum reservoir to flush the line. Verify that both U-Tubes are immersed in liquid argon. Inject 1-5000 uL of sample through the septum, making sure that the end of the needle extends past the juncture of the vee.

Using the vacuum reservoir, draw about 500 mL of zero air through the U-tube thereby carrying the injected sample with it. Switch the 8-port valve so that the canister is no longer connected to the vacuum reservoir. Proceed with steps 5.3.8 through 5.3.12.

5.3.14 Verify that the sample identity, size, log number and description on the GC/MS file header match those on the injection record and on the Chain of Custody document. Start the gc/ms run.

5.3.15 Immediately/simultaneously remove the column loop from the liquid nitrogen and gently push it back into the oven. Apply the hair dryer to any exposed portions of the column in order to "chase" higher boiling materials into the analytical system.

5.3.16 The analytical column is held at -10 C for 3 minutes after which the temperature is increased 10 /min to 220 C. Scan from m/z 25 to m/z 180 if BFB is to be verified with every run. Otherwise m/z to m/z 50 is sufficient for ethylene oxide. The smaller mass range will improve sensitivity somewhat. If selective ion mass spectrometry is employed, the sensitivity is improved still further. Masses m/z 29 and m/z 44 are recommended. A third mass may be employed for the internal standard if one is used.

6.0 Results and Discussions - The major subsections which follow deal with the calibrations required for each of the methods, with the establishment or estimation of detection limits for each of the methods, with the results of the ambient surveys and with the results of the source tests.

6.1 Calibrations - Initial calibrations for all laboratory methods shall be based on a minimum of three nonzero levels with the blank constituting the fourth point. The minimum acceptable least squares fit shall be 0.99. Curves shall be either established daily or verified with a standard which provides results within 20% of the true level. Verification of calibration shall be required every 12 hours of operation. Instrument responses per unit weight injected, normalized to the internal standard where appropriate, shall be compiled for control chart analysis. Results not falling within +/- three standard deviations shall require investigation prior to running samples. Consecutive results beyond two standard deviations in the same direction shall also require investigation prior to running samples.

6.2 Detection Limits - Detection limits were mathematically established, except where described as preliminary, according to the method of Glaser et al (2). In this method, seven replicate analyses are performed at a level estimated to be three to five times above the detection limit. The standard deviation is calculated and multiplied by the student t-statistic corresponding to the 99% confidence level (3.146). This is the method detection limit (MDL). Placing a 95% confidence band around the MDL using the chi square statistic (2.20) defines the practical quantitation limit (PQL), or limit of detection.

6.2.1 PID, Field - NIOSH Method 3702 which employs a portable gas chromatograph believed to be the same Photovac 10S50 used by CCAS and CARB for field testing at ethylene oxide sterilization units lists the range of the method as 0.001 ppmv to 1000 ppmv. The detection limit is separately listed as 1 ppbv (5). A separate communication with the manufacturer (7) agrees that 1 ppbv is the detection limit for a 1 mL sample. This is the largest sample volume which can be handled by the field instrument. Since the NIOSH method has been subjected to rigorous validation, no further work was necessary to develop mathematically rigorous detection limits before use in support of the project. Practical considerations, based on observations in the field using the Photovac 10S50, suggest that 50 ppbv might be more realistic for routine work.

6.2.2 PID, Laboratory - The lamp employed for this testing was the popular 10.2 ev lamp which has a secondary output at 10.6 ev. Since only the latter is above the ionization potential of ethylene oxide, the signal produced is not of optimal strength - i.e., the signal strength recorded in the CCAS laboratory was only strong enough to provide a detection limit of 1.5 ug. This corresponds to 40 ppbv in a 12 L sample such as would be the case if samples were collected using the U-Tube method. If the canister method were used instead, then a maximum volume of only 1 L could be transferred to the analytical system thereby providing a detection limit of 500 ppbv. In this case, a mathematical verification of the detection limit was established as shown in Table 3. The difference between the laboratory and field detection limits is in the opposite direction of what is normally observed. In this case, the difference is due to the fact that the laboratory instrument had a primary energy output of only 10.2 ev whereas the field instrument had an output of 11 ev. The decision to

employ a lamp of lower energy in the laboratory for the rigorous establishment of the MDL and PQL was necessitated by the fact that the omission of the mathematical proof was not discovered until the instrument originally used and employing an 11 ev lamp had been returned to Dr. Pierotti. The estimated MDL and PQL based on a visual comparison of signal to noise were 12 pptv and 5 pptv respectively (U-Tube Method).

6.2.3 Quadrupole GC/MS Full Scan - The Hewlett Packard Model 5970 MSD quadrupole mass spectrometer and the Hewlett Packard 5890 gas chromatograph were employed for the establishment of the detection limit for this method. The mass range scanned was m/z 28 to m/z 45. As shown in Table 4, the method detection limit was mathematically established at 0.4 ppbv. Since the standards were introduced using the canister transfer system, the detection limit for U-Tubes would be 40 pptv. An example fragmentation pattern is provided as Exhibit 17.

6.2.4 Quadrupole GC/MS Selective Ion Monitoring (SIM) - Again the MDL was mathematically established using the Hewlett Packard Model 5970 MSD quadrupole mass spectrometer and the Hewlett Packard 5890 gas chromatograph. Samples were introduced by means of the canister sample transfer system resulting in a practical quantitation limit (PQL) of 20 pptv. Had the U-Tube method been employed, the detection limit would have been 2 pptv. The mathematical proofs are presented in Table 5.

6.2.5 Ion Trap GC/MS - In this case, the Finnigan MAT ion trap detector (ITD) and the Hewlett Packard Model 5890 gas chromatograph were used to estimate the detection limits (practical quantitation limits) on the basis of signal to noise ratios. This method is not as rigorous as the mathematical method but typically agrees within a factor of two. Samples were introduced by means of the canister sample transfer system resulting in a practical quantitation limit (PQL) of 10 pptv. Had the U-Tube method been employed, the detection limit would have been 1 pptv.

6.3 Ambient Surveys - Having developed five successful analytical methods and two successful sample collection methods for a total of nine analytical permutations, CCAS and CARB found themselves in the enviable position of having completed the major thrust of the project ahead of schedule and under budget. A greater opportunity was therefore created to perform sampling and analysis than had originally been planned. This was especially true in the case of the ambient surveys since it was not necessary in such cases to secure the willing cooperation of a potentially regulated party as later proved to be a major obstacle in the case of the site testing. Virtually all of the ambient work was performed by Ion Trap GC/MS following U-Tube sample collection and two-dimensional chromatographic removal of cocollected water.

6.3.1 Global Tropospheric Background - The proximity of CCAS' facility at San Luis Obispo, California to sparsely populated sections of the coast at Montana de Oro and Big Sur led us to collect samples at these locations upon several occasions. These samplings were further spurred by recent concerns about the mutagenic and carcinogenic properties of ethylene oxide coupled with the realization that the atmospheric lifetime of ethylene oxide might be as long as 100 to 200 days. Since the atmospheric lifetime of EO is now believed to be comparable to that of carbon monoxide for which a global distribution has been established, a global background of 10-30 pptv seemed likely.

Samples taken at these remote coastal locations during conditions of onshore flow have established a global background in this range as shown by the data presented in Table 7. The excellent agreement among the multiple samples taken at Montana de Oro on March 19, 1990 and at Big Sur on May 24, 1990 is a measure of both sampling and analytical precision. The variable nature and the unexpectedly higher results recorded at Point Reyes and Bodega Head on July 26, 1990 are difficult to explain since there were no known sources in the area. While it is possible that there is a local source in the area and/or a sewage outfall which, in turn, contains EO, additional ambient sampling was not performed. Aside from the aforementioned exceptions, these results clearly indicate that there is a global background for ethylene oxide and that it is both consistent with reported atmospheric lifetimes and above levels indicated by some to present a health risk.

6.3.2 Los Angeles Basin - Heavy usage of ethylene oxide within the Los Angeles area coupled with restricted airflow out of the basin led us to suspect that relatively elevated levels might be found within this region. While most samples were taken with U-Tubes, some canister samples were also collected. Results were generally in the ppbv range with some in the low ppmv range. A high degree of local variability was observed suggesting that "puffs" of elevated concentration were drifting over impacted neighborhoods in response to the cyclic nature of releases expected during the sterilization cycle. Representative data are presented in Tables 8 through 11. The May 8, 1990 sampling was performed in conjunction with a number of persons from the Air Resources Board who used a van equipped with their own air monitoring equipment.

Although ethylene oxide concentrations are generally elevated well above background in urban areas, these results show they can fall to near background levels even in the Los Angeles area. Additionally some of the samples from urban areas not directly affected by any ethylene oxide sources appear to show concentrations below those generally observed in clean air. This apparent inconsistency may have been due to sampling difficulties which might have caused the volumes actually collected to be significantly less than recorded such as would be the case if there was a post-sampler leak in the U-tube system. This possibility, however, seems less likely than the possibility that there may be reactions between ethylene oxide and urban smog which cause ethylene oxide to disappear.

6.3.3 Salinas - A large spice processing facility in Salinas provides a possibly significant point source in an otherwise rural, coastal environment. Samples were first taken on September 14, 1989 during conditions of fair weather and strong winds. The odor of the spices was helpful in determining a true downwind position. No corresponding upwind samples were taken. This omission reflects the fact that the 1989 sampling was only a preliminary study, designed to field test the sampling equipment and protocol with samples likely to contain above-ambient levels. The study was not intended to be a source characterization. Levels reported in Table 12, however, were generally between one and two orders of magnitude above those believed to be typical of global tropospheric background.

6.3.4 Northern California - Sample collections were made in northern California in June and July of 1990. Relatively high concentrations were found in some Silicon Valley locations with the highest values noted being in the vicinity of the Sunnyvale sewage treatment plant. This would suggest that ethylene oxide discharges such as might arise from sterilization condensates may be a significant source of local atmospheric contamination at points other than the sterilizer facility itself. In general, sampling locations were selected based on proximity to a potential point source, proximity to potential non-point sources and the absence of any potential sources.

Although this subsection describes the results obtained from several hundred measurements of ethylene oxide at locations throughout California, it is difficult to make many definitive statements regarding its spatial and temporal distribution. Concentrations were found to be extremely variable in urban areas with only a few minutes being required to provide concentration shifts of 100-fold. For example, EO sampled at Vernon on 8/9/90, 0.041 vs 03.9 ppv approximately 20 minutes later, Anaheim 8/10/90 120, 2.6, 1.5 approximately 20 minutes between first and last - see Table 10.

6.4 Source Tests - Direct testing of emissions control devices at facilities using ethylene oxide proved to be extremely difficult to arrange due to the need to coordinate a sampling schedule between the California Air Resources Board, the local Air Quality Control District, the facility owner and the laboratory. Difficulties were encountered in obtaining the cooperation of the facility owners.

6.4.1 Source Test - A test was jointly conducted at the San Antonio Hospital in Upland, California on March 6-7, 1991. Participants were CCAS, the California Air Resources Board and the South Coast Air Quality Management District. Only the results provided by CCAS are provided in this report. This was the only source test actually conducted although several others had been planned and at least one other got as far as being scheduled before being postponed indefinitely.

The results which are presented in Table 14 were generated from canister samples taken before and after the control device and analyzed in the laboratory by the ion-trap GC/MS method. ARB and SCAQMD source testing teams also conducted in line sampling and analysis using the field GC/PID method. These results are not currently available to CCAS. This test indicated that the ethylene oxide concentrations in the vent gases were much lower than CCAS had expected, both in the inlet and outlet sides of the control device. The control device at the San Antonio Hospital is a catalytic oxidizer which dilutes the vent gases from the sterilization chamber before they are passed through the catalytic oxidation bed. We believe the fact that inlet gas concentrations were generally much less than 0.1 percent was due to the way in which the sterilization chamber evacuation is carried out. Instead of evacuating the chamber rapidly and thereby sending a large amount of ethylene oxide into the catalytic oxidizer at one time, the chamber is apparently evacuated in increments with small amounts being released in bursts. These bursts of released EO become rapidly diluted before passing into the control device. The fact that the largest concentrations recorded occurred near the end of the evacuation sequence indicates that a great deal of residual sterilizing gas is present up to the very end of the process. Therefore, it would be necessary to conduct future measurements throughout the entire evacuation sequence in order to determine if facilities of this design are in compliance.

Inlet concentrations were found to vary by a factor of 1000 while outlet concentrations were found to vary only by a factor of two. Attempting to establish correspondence between inlet and outlet is very difficult. It should be pointed out, however, that some inlet concentrations were actually lower than some outlet concentrations. One possibility may be that this catalytic oxidizer was not operating very efficiently during this test period.

The difficulty in determining compliance will depend upon how the compliance regulations are written. For example, if they require that the control device remove greater than 99 percent or 99.9 percent at all stages of the evacuation sequence, then establishing compliance may be very difficult for facilities such as the San Antonio Hospital. However, if the regulations simply require that 99 percent or 99.9 percent of the total ethylene oxide be removed over the entire evacuation sequence, then it may be more practical to integrate the inlet and outlet concentrations with flow data to arrive at an overall efficiency based on pounds entering the control device relative to pounds leaving the control device. At least as much care will have to be focussed on flow measurements as is focussed on concentrations. High variabilities in both seem likely. Thus, correlations aimed at evaluating control device efficiencies must include flow rates as well as concentrations. Removal must therefore be determined on a mass basis. Some way of flow proportioning a whole-process, time integrated sample would seem to offer the best opportunity for success. If discrete samples are to be taken as would be the case if the Photovac 10S50 or similar on-line instrumentation were operated in cyclic fashion, measurements would not be taken often enough to deal with the sharp variabilities in concentrations observed during this testing experiment. This problem, of course, should not be insurmountable. Further studies may be necessary in order to determine how integrated, flow proportioned sampling might best be incorporated into control device efficiency testing requirements. This incorporation would seem to be necessary whether on-line testing or sampling followed by laboratory analysis were to be applied for the determination of concentrations. CCAS currently favors laboratory analyses because:

- * Field Analyses would require the use of more highly trained field personnel than would be the case if they were only collecting samples. Such persons are currently in short supply.

Precision cannot be assessed with real samples in the field since the entire sample is consumed in the analysis. This would not be the case if samples were collected for subsequent laboratory analysis using SUMMA electropolished stainless steel canisters.

- * Laboratory conditions are more easily controlled for uniformity than is possible for field conditions.

- * Accuracy is better controlled in a laboratory environment.

- * Laboratory instruments are generally more sensitive than field instruments.

APPENDIX

LIST OF TABLES

1. Stability of Ethylene Oxide in SUMMA Electropolished canisters
2. BFB Key Ions and Ion Abundance Criteria
3. Method Detection Limit Study - Photoionization Detector (PID)
4. Method Detection Limit Study - Full Scan Quadrupole GC/MS
5. Method Detection Limit Study - Quadrupole GC/MS with selective ion monitoring
6. N/A
7. EO Concentrations in Remote Coastal Locations
8. 25 Ambient Measures, LA, March 26 & 27
9. 46 Ambient Measures, LA, May 8 & June 30
10. 36 Ambient Measures, LA, August 9, 10 & Fall
11. 22 Ambient Measures, LA, July 19 & 20
12. 8 Ambient Measures, Salinas
13. 36 Ambient Measures, No. California
14. Source Testing at San Antonio Hospital, Upland CA
March 6 & 7, 1991

TABLE 1

CANISTER STABILITY
PERCENT RECOVERIES OF ETHYLENE OXIDE
AT VARIOUS CONCENTRATION LEVELS

Days after preparation	10 ppbv	90 ppbv	1000 ppbv
1	-----	63 (70%)	1100 (110%)
2	-----	44 (49%)	1100 (110%)
5	-----	24 (27%)	1100 (110%)
10	-----	19 (21%)	1000 (100%)
15	-----	-----	1100 (110%)
24	-----	-----	1000 (100%)
30	-----	-----	1000 (100%)

TABLE 2

BFB (1) KEY IONS AND ION ABUNDANCE CRITERIA

MASS	Ion Abundance Criteria
50	15.0 - 40.0 percent of the base peak
75	30.0 - 60.0 percent of the base peak
95	base peak, 100 percent relative abundance
96	5.0 - 9.0 percent of the base peak
173	less than 2.00 percent of mass 174
174	greater than 50.0 percent of the base peak
175	5.0 - 9.0 percent of mass 174
176	greater than 95.0 percent but less than 101.0 percent of mass 174
177	5.0 - 9.0 percent of mass 176

Contract Laboratory Program Statement of Work for Organics
Analysis (USEPA, 1990).

(1) BFB p-bromofluorobenzene

TABLE 3

MDL STUDY OF ETHYLENE OXIDE ON GC/PID

RUN #	Total ug	CONC (ppbv) *
1	1.7	90
2	2.8	140
3	2.2	110
4	1.7	90
5	2.6	130
6	2.1	110
7	3.1	160
Avg	2.3	120
SD	0.5	26

$$df = 7$$

$$t_{0.99} = 3.146$$

$$MDL = (26) (3.146)$$

$$MDL = 82 \text{ (round to 80)}$$

*Conc. ppbv is base on 6L loading

TABLE 4

MDL STUDY - FULL SCAN QUADRUPOLE GC/MS

RUN #	CONC (ppbv)
1	2.9
2	2.8
3	2.7
4	2.8
5	3.0
6	2.9
7	2.6
Aug	2.8
SD	0.13

fd = 7

$t_{0.990} = 3.146$

PQL = MDL = 0.4 ppbv

TABLE 5

MDL STUDY - QUADRUPOLE GC/MS WITH SELECTIVE ION MONITORING

RUN #	CONC (pptv)
1	73
2	79
3	87
4	69
5	78
6	77
7	77
Avg	77
SD	5.6

$$df = 7$$

$$t_{0.99} = 3.146$$

$$MDL = (3.146) (5.6)$$

$$= 0.02 \text{ ppbv}$$

TABLE 7 - EO Concentrations in Remote Coastal Locations

Location	Date	Concentration in pptv
Big Sur	Autumn 1989	25, 25 (two samples)
Montana de Oro	04/19/90	16 +/-1 (mean of 4)
Big Sur, Pfeiffer Point	05/24/90	19 +/-3 (mean of 9)
Big Sur	07/12/90	23
Point Reyes	07/26/90	23, 86, 200
Bodega Head	07/26/90	150, 33, 180

TABLE 8 - EO Concentrations in the Los Angeles Area
March 26 and 27, 1990

Location	Date	Time	Concentration in ppbv
Pasadena	March 26, 1990	17:35	0.07
		17:40	0.03
		17:50	0.02
Burbank	March 26, 1990	18:30	0.08
		18:35	0.11
		18:40	0.05
		18:45	0.03
Downtown LA	March 27, 1990	06:35	0.63
		06:38	0.80
		06:41	0.79
		06:45	0.73
Vernon	March 27, 1990	07:45	8.1
		07:48	470.
		07:51	84.
		07:55	11.
N. Long Beach	March 27, 1990	09:10	0.09
		09:15	0.05
		09:20	0.21
Westwood	March 27, 1990	10:15	0.13
		10:25	0.27
		10:30	0.15
Azusa	March 27, 1990	12:30	0.12
		12:35	0.55
		12:40	0.12
		12:45	0.05

TABLE 9 - EO Concentrations in the Los Angeles Area
May 8 and June 30, 1990

Location	Date	Time	Concentration in ppbv
Vernon, near van	May 8, 1990	06:42	3.4
		06:45	26.
		06:47	4.5
		06:52	11.
		07:24	2.1
		07:28	20.
		07:32	5.9
		07:35	16.
		07:40	31.
		08:25	19.
		08:33	0.37
		08:37	0.34
		08:45	30.
		09:38	12.
		09:42	28.
		09:45	4.5
09:50	100.		
09:55	140.		
Vernon, Gifford&49th	May 8, 1990	08:10	5.9
		09:00	3100.
		09:10	0.44
		09:13	0.43
		09:17	55.
		09:21	24.
Los Angeles, Downtown	May 8, 1990	12:00	0.07
		12:02	0.04
		12:04	0.07
		12:08	0.12
		12:15	0.12
Los Angeles, Downtown	June 30, 1990		0.032
			0.12
Los Angeles Airport	June 30, 1990		0.037
			0.049
			0.024
Downey	June 30, 1990		0.031
			0.052
			0.036
			0.034
Fullerton	June 30, 1990		0.045
			0.11
Long Beach	June 30, 1990		0.085
			0.054
			0.048
			0.023

TABLE 10 - EO Concentrations in the Los Angeles Area
August 9 and 10, 1990

Location	Date	Time	Concentration in ppbv
Vernon	August 9, 1990	morning	28.
			81.
			11.
			40.
Vernon	August 9, 1990	afternoon	0.041
			0.32
			3.9
			0.066
Vernon	August 10, 1990	noon	0.14
			0.55
			1.5
			0.36
Los Angeles, Downtown	August 9, 1990	morning	0.020
			0.034
			0.028
			0.020
Irwindale	August 9, 1990	morning	1.0
			0.10
			0.090
			0.090
Irwindale	August 9, 1990	afternoon	0.12
			0.33
			0.029
Anaheim	August 10, 1990	morning	120.
			2.6
			1.5
			5.7
Irvine	August 10, 1990	morning	0.12
			0.36
Rosemead	Fall, 1990	morning	0.11
			0.23
			0.077
			0.11
Rosemead	Fall, 1990	afternoon	0.11
			0.026
			0.079
			0.11

Table 11 Ethylene Oxide Measurements in Los Angeles
July 19 and 20, 1990

Location	Date	Concentration in ppbv
Los Angeles, downtown	July 19, 1990	0.18
		0.17
		0.17
		0.070
Anaheim	July 19, 1990	6.5
		16.
Irvine	July 19, 1990	0.58
		0.044
		0.061
		0.027
Loma Linda	July 20, 1990	0.023
		0.030
		0.018
		0.013
Riverside	July 20, 1990	0.023
		0.021
		0.033
		0.015
Duarte	July 20, 1990	0.023
		0.047
		0.042
		0.023

Table 12 Ethylene Oxide Measurements in Salinas

Location	Date	Time	Concentration in ppbv
Eden Street, downwind	September 14, 1989	16:42	3.0
		16:52	0.41
		16:57	3.9
		17:04	1.4
		17:11	1.3
Downwind	June 20, 1990		1.1
Upwind	June 20, 1990		0.025
Downwind, no odor	July 15, 1990		0.018

Table 13 Ethylene Oxide Measurements in Northern California

Location	Date	Concentration in ppbv
San Francisco	June 18, 1990	0.028
		0.028
		0.021
		0.018
		0.022
San Francisco	July 27, 1990	0.049
		0.019
		0.070
Palo Alto	June 19, 1990	0.032
		0.048
Palo Alto	July 13, 1990	0.023
Cupertino	June 19, 1990	0.11
		0.29
		0.12
San Jose	June 19, 1990	0.045
		0.029
San Jose	July 14, 1990	0.022
Hayward	June 19, 1990	0.014
		0.022
Oakland	June 19, 1990	0.026
		0.12
Piedmont	June 19, 1990	0.053
		0.013
Concord	June 19, 1990	0.017
		0.054
Sacramento	June 19, 1990	0.045
Rancho Cordova	June 20, 1990	0.038
		0.19
Gilroy	June 20, 1990	0.034
Sunnyvale	July 13, 1990	0.070
		0.11
		0.054
Sunnyvale	July 14, 1990	0.094
		0.30
Santa Clara	July 13, 1990	0.093
San Carlos	July 27, 1990	0.22

TABLE 14

Source Testing at San Antonio Hospital,
Upland, California, March 6 & 7, 1991

EVACUATION SEQUENCE, OUTLET (3/6/91)

TIME	CAN #	ETO (ppmv)
13:35	W-20	0.06
13:40	U-238	0.08
13:45	Sample lost, valve broken	
13:50	P-113-P	0.05
13:55	B-470	0.29
14:00	V-354	0.38
14:05	TV-605	0.15
14:10	B-104	0.20
14:15	123	0.14
14:20	401	0.22

AERATION SEQUENCE, OUTLET (3/6/91)

TIME	CAN #	ETO (ppmv)
15:15	403	0.003
15:30	125	0.006
15:45	511	0.08
16:00	518	0.05

TABLE 14
(continued)

EVACUATION SEQUENCE, INLET (3/7/91)

TIME	CAN #	ETO (ppmv)
13:20	4	0.3
13:25	9	210.
13:30	31	0.2
13:35	421	170.
13:40	14	3.0
13:45	102	190
13:50	34	13.
13:55	300	0.3
14:00	7	14.
14:05	35	0.9
14:10	6	1800.
14:15	527	140.

EXHIBIT LIST

1. Reaction of Ethylene Oxide (EO)
2. Chromatogram showing separation of EO, propane, acetaldehyde, CO₂
3. Mass spectra of EO, propane, acetaldehyde and CO₂
4. Mass chromatograms of EO standard analyzed directly and after passing through NaHCO₃ trap (from Finnigan Technical Bulletin)
5. Schematic U-Tube sample collection system
6. Diagram of U-Tube cryogenic sample trap
7. Transfer from U-Tube to analytical system
8. Sodium Bicarbonate cartridge for removing acid mists
9. Schematic canister sample collection system
10. Canister cleaning system, adapted from EPA TO-14
11. Example canister use form
12. Transfer from canister to analytical system
13. Ethylene Oxide Stability Study - 1 day and 1 week
14. Ethylene Oxide Stability - 12 days and 22 days
15. Diagram of Scrubber Vent Sampling System for use with portable GC
16. Sequence of Valve Positioning, Onsite Scrubber Vent EO Analysis
17. Example Quadrupole GC/MS Fragmentation for EO

EXHIBIT 1

COMMERCIALY IMPORTANT REACTIONS OF ETHYLENE OXIDE

With:

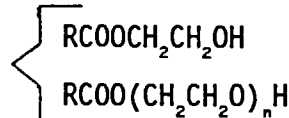
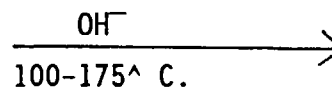
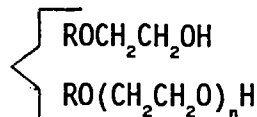
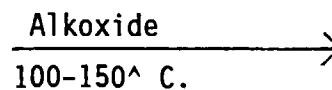
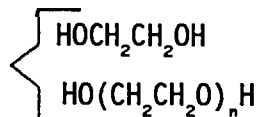
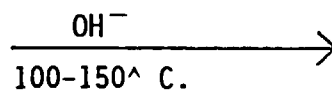
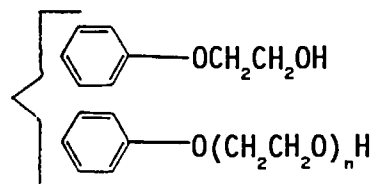
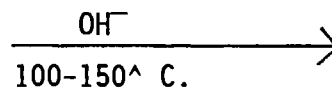
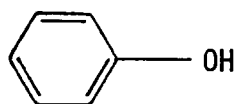
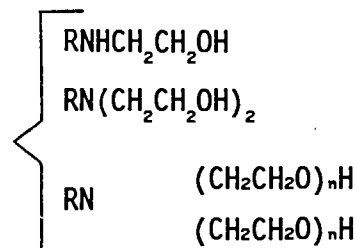
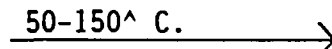
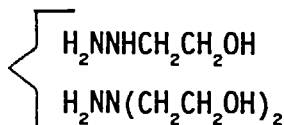
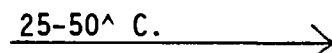
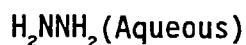
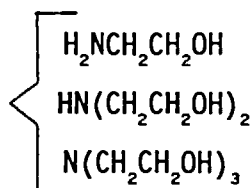
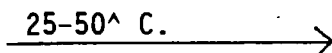
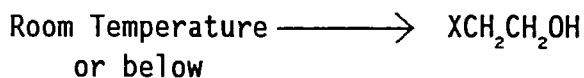
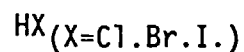
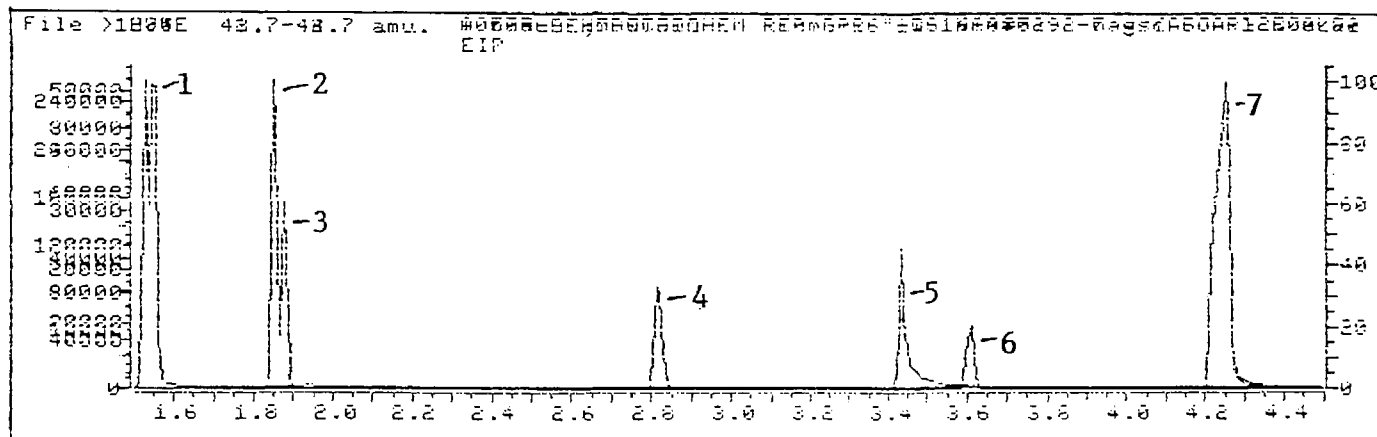

Exhibit 2

Chromatogram Showing Separation of
EO, Propane, Acetaldehyde, CO₂



1. CO₂
2. Propene
3. Propane
4. Iso-Butane
5. Acetaldehyde
6. Ethylene Oxide
7. Butane

COLUMN: J & W DB-5, 30 m. 0.25 mm dia.

CARRY GAS: He. 1 ml/min.

TEMPERATURE PROGRAM: -50°C, 2 min.
RATE: 12°/min. to 80°C
RATE: 25°/min. to 220°C
220°C 2 min.

Exhibit 3

Mass Spectra of E0, Propane, Acetaldehyde, CO₂

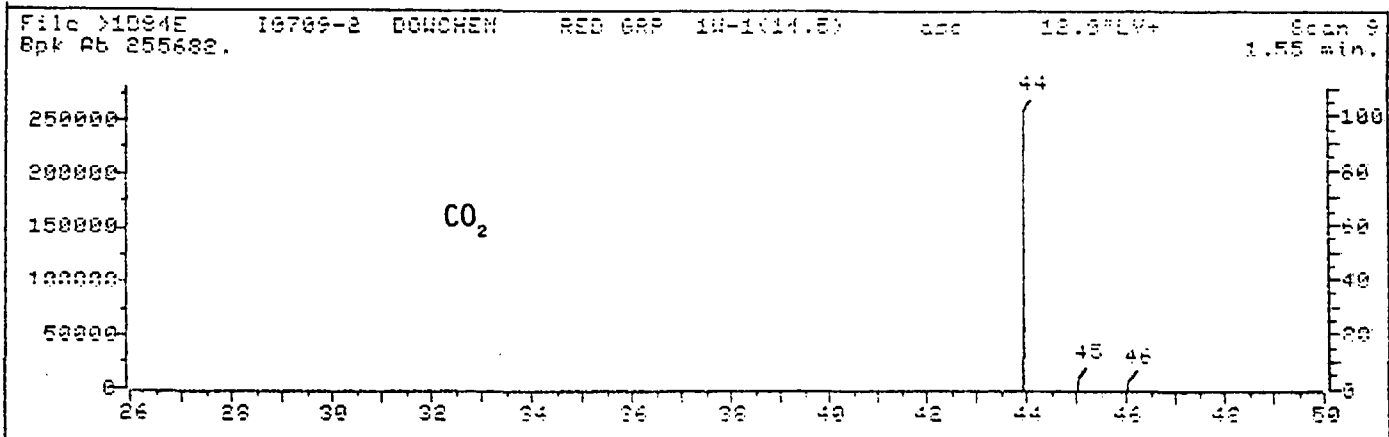
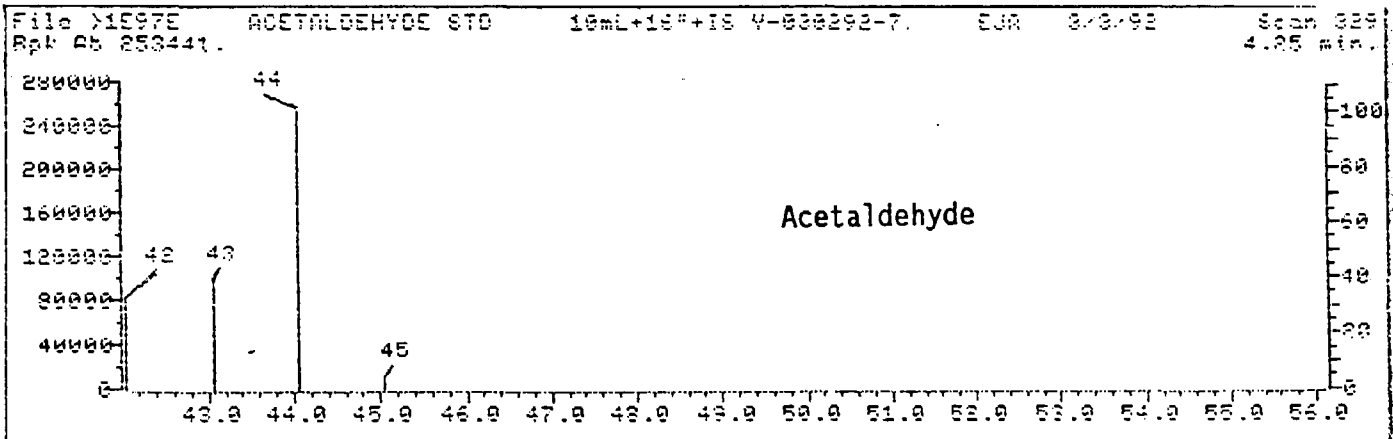
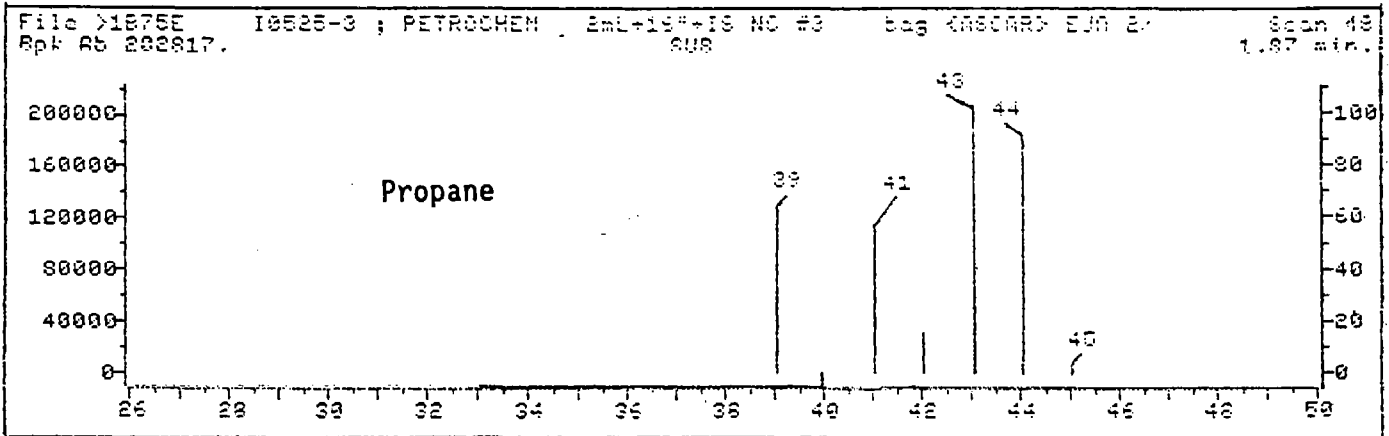
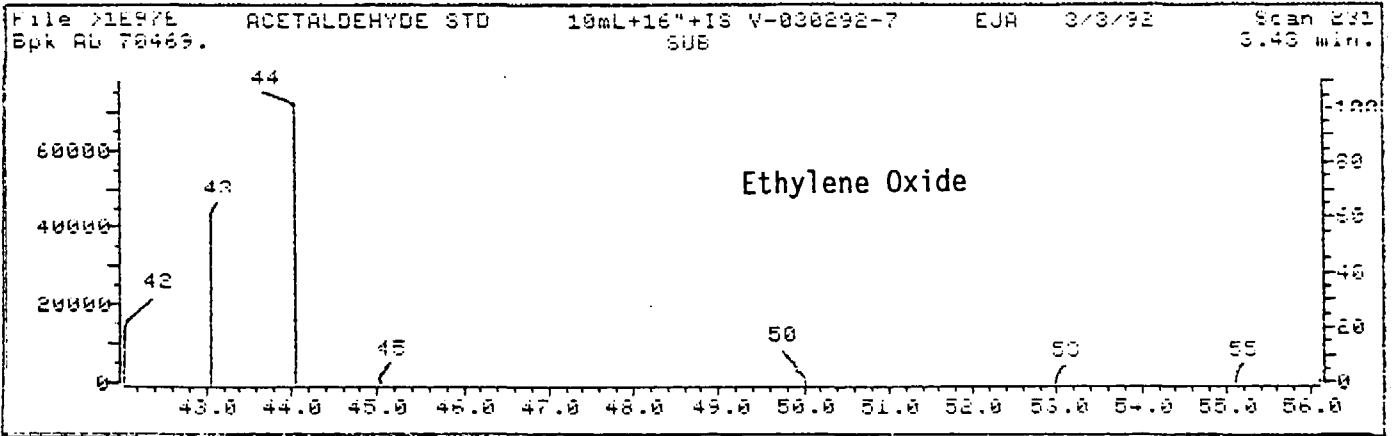
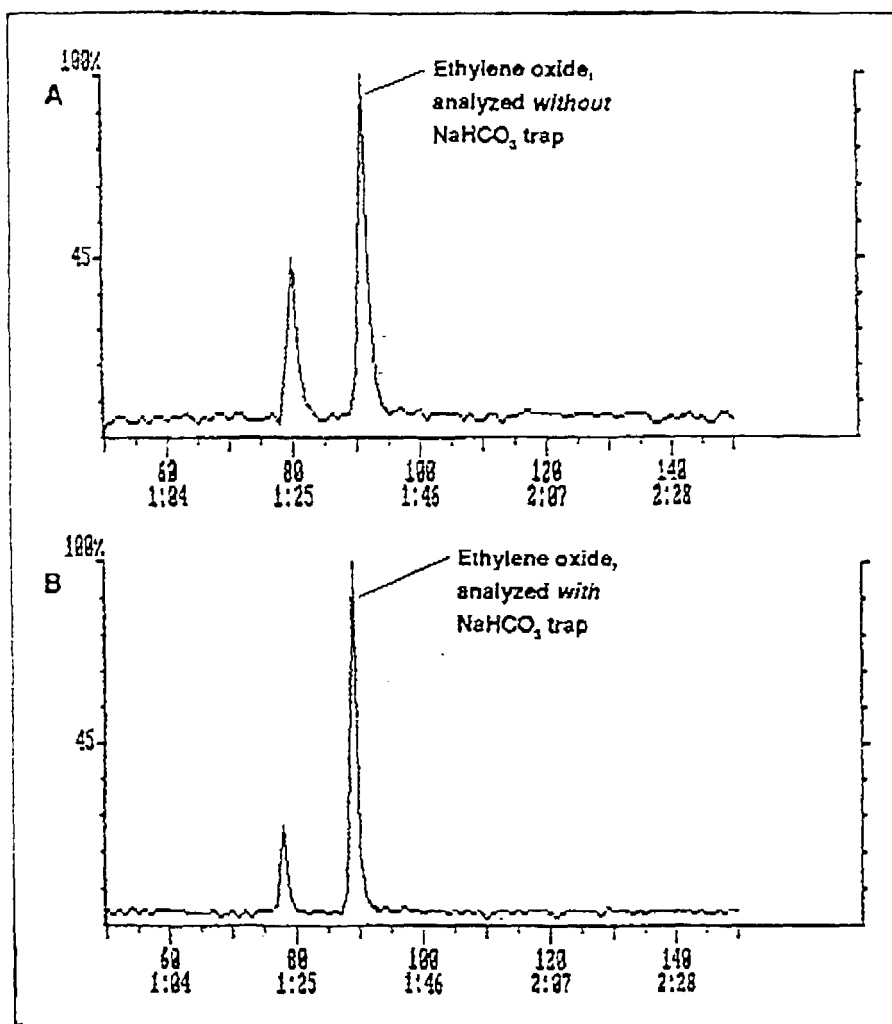

Exhibit 4

Mass Chromatograms of EO Standard
Analyzed directly and after passing
through NaHCO₃ Trap



EO area counts within 1%

Exhibit 5

Schematic U-Tube Sample Collection System

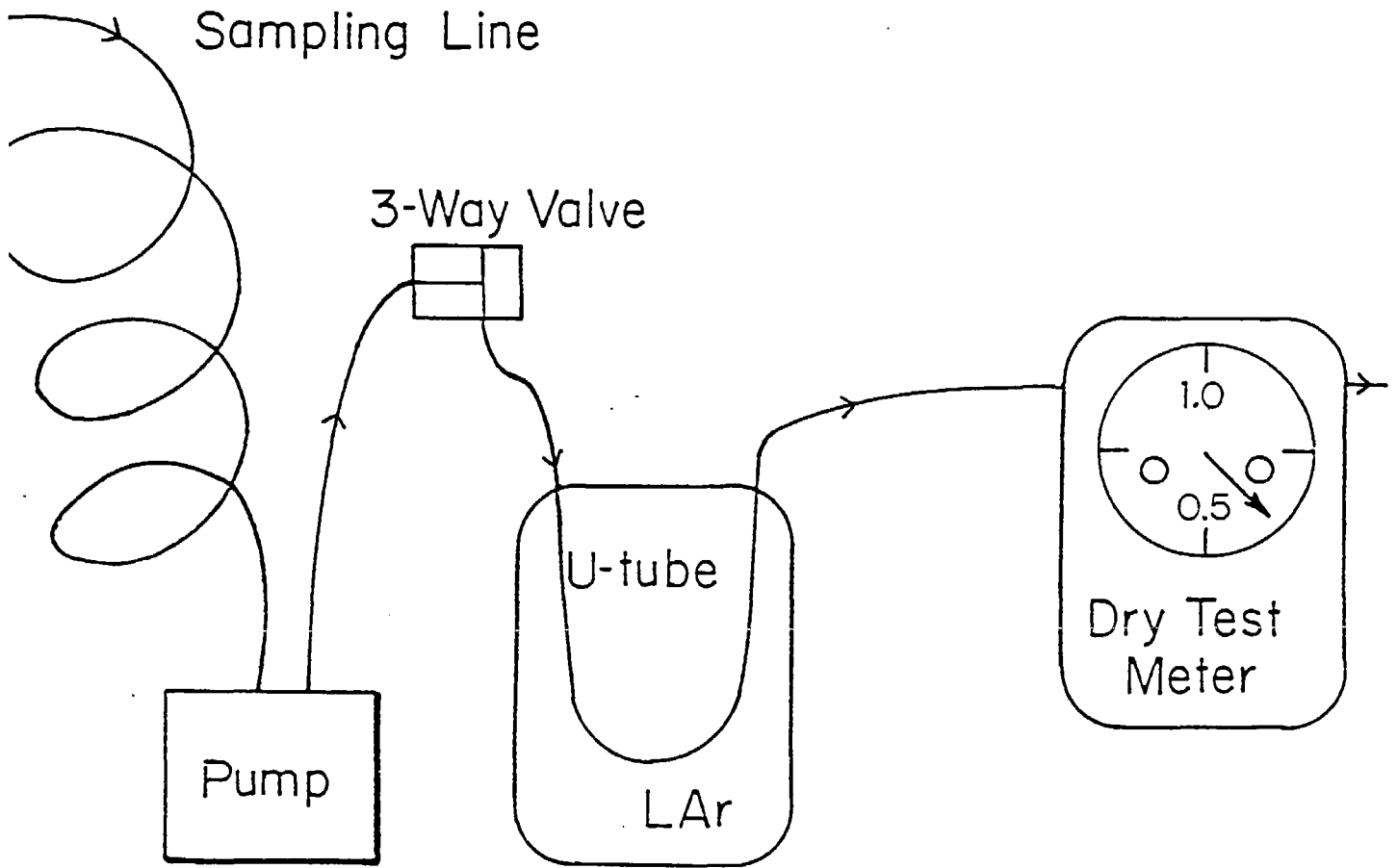

Recommended for Ambient Testing Only

Exhibit 6

U-Tube Cryogenic Sampling Trap

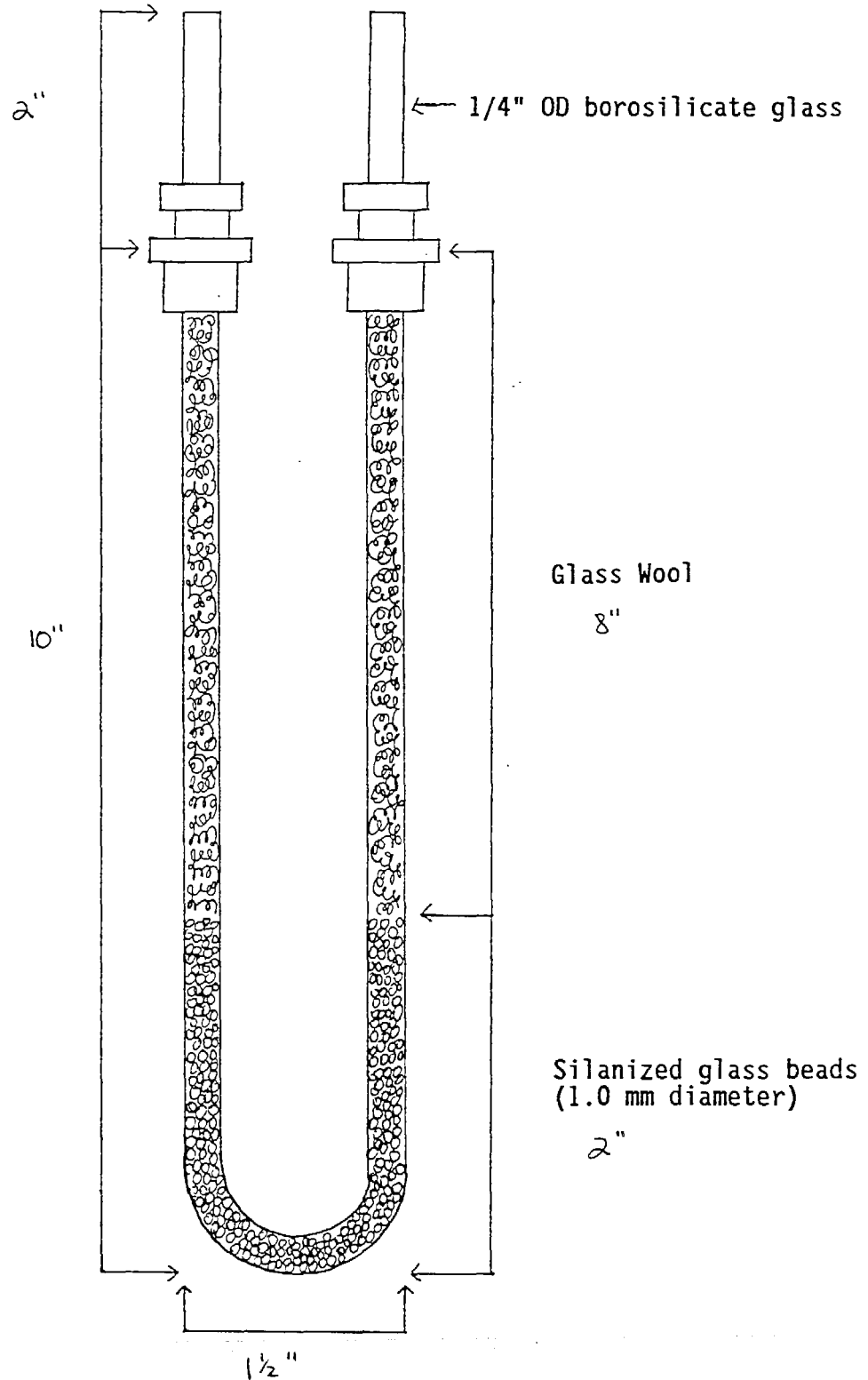

Exhibit 7

Transfer from U-Tube to Analytical System

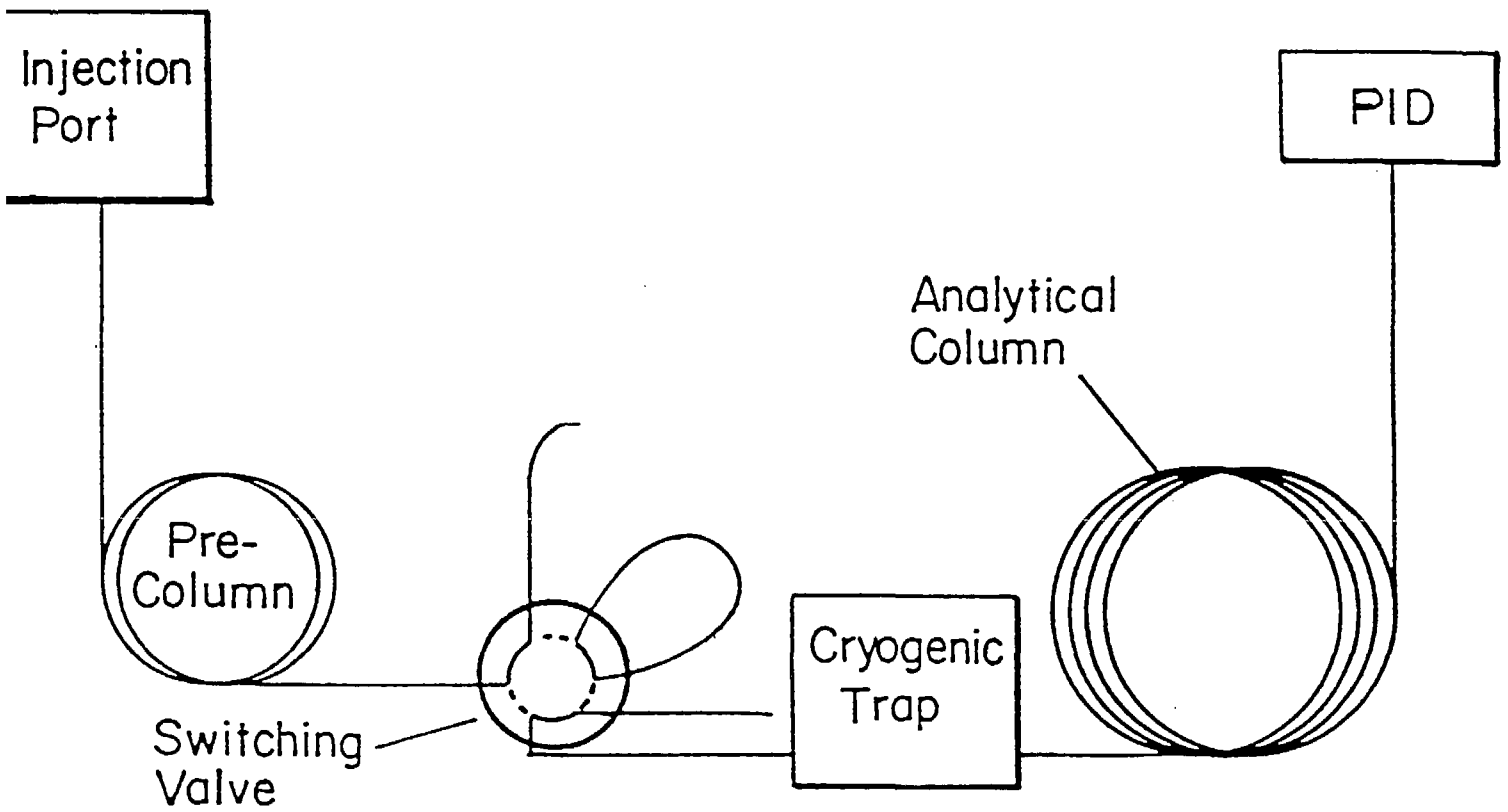
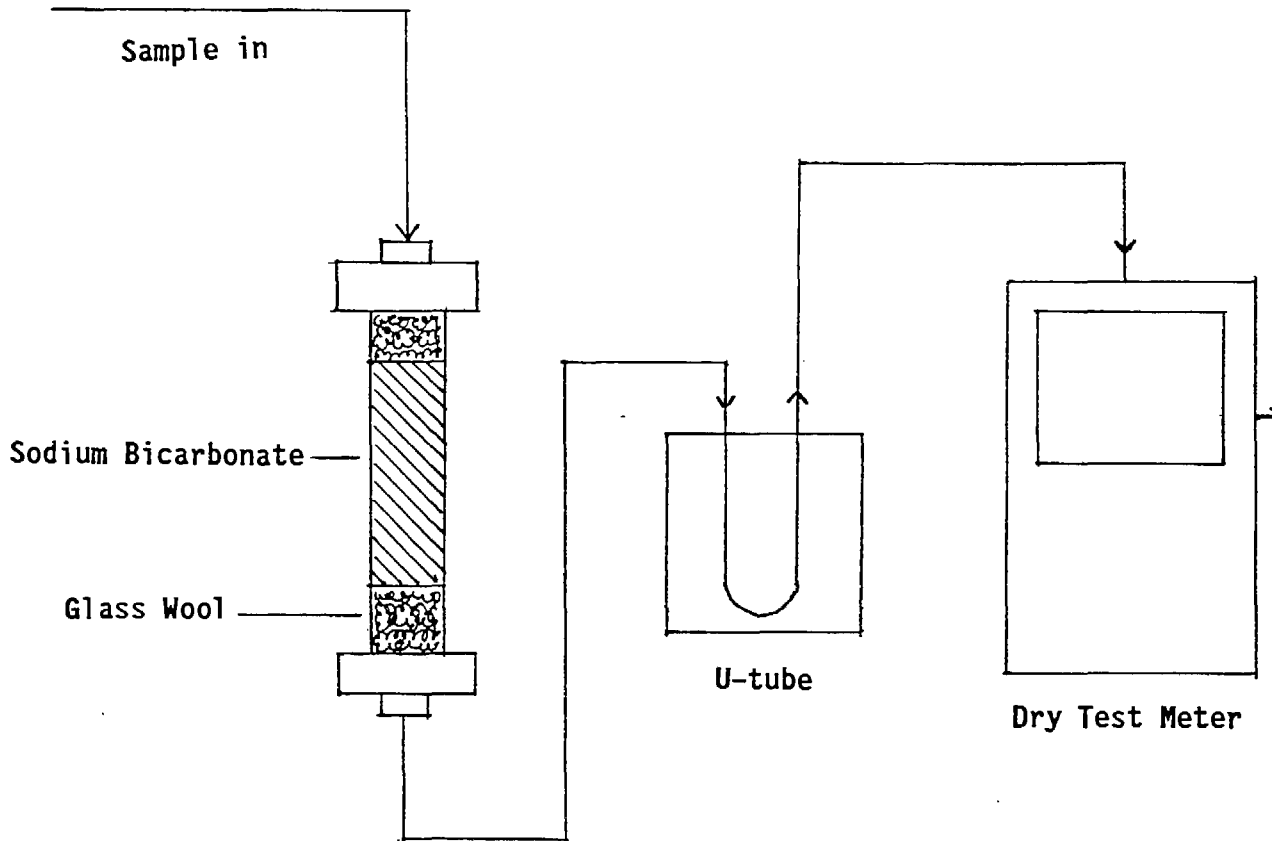

Exhibit 8

Sodium Bicarbonate Cartridge for
Removing Acid Mists



Compare with Exhibit 5. Normally one would use a cartridge with canisters or bags or a field-PID. The U-tube is better suited for ambient sampling.

Exhibit 9
Schematic Canister Sample
Collection System

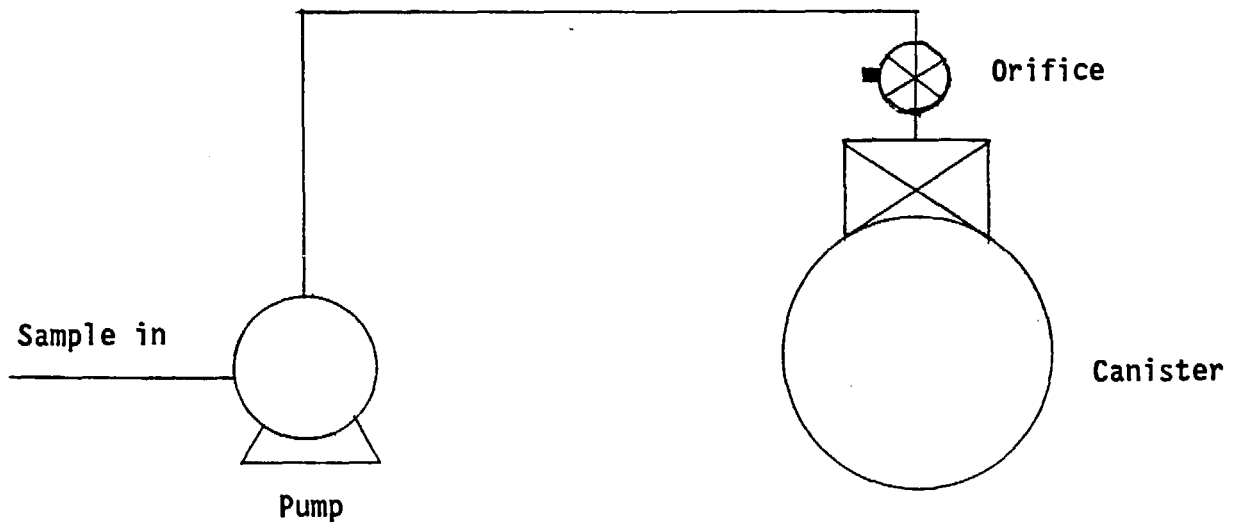

Exhibit 10

Canister Cleaning System
Adapted from EPA T0-14

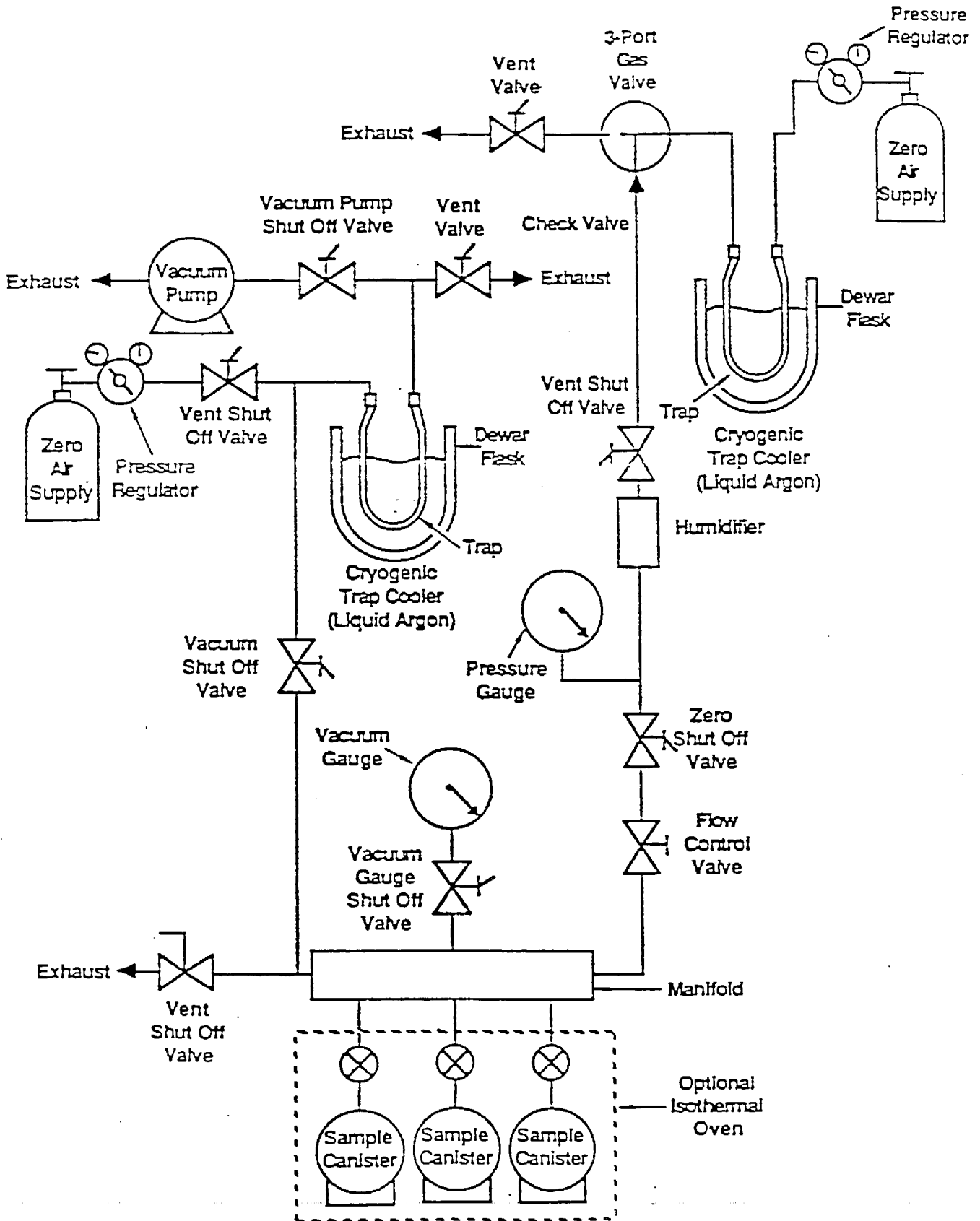

Exhibit 11
Example Canister Use Form

CANISTER SAMPLING FIELD DATA SHEET

A. GENERAL INFORMATION

SITE LOCATION: _____
 SITE ADDRESS: _____

 SAMPLING DATE: _____

SHIPPING DATE: _____
 CANISTER SERIAL NO.: _____
 SAMPLER ID: _____
 OPERATOR: _____
 CANISTER LEAK
 CHECK DATE: _____

B. SAMPLING INFORMATION

	TEMPERATURE				PRESSURE	
	INTERIOR	AMBIENT	MAXIMUM	MINIMUM	CANISTER PRESSURE	
START			 	 		
STOP					 	

	SAMPLING TIMES		FLOW RATES		
	LOCAL TIME	ELAPSED TIME METER READING	MANIFOLD FLOW RATE	CANISTER FLOW RATE	FLOW CONTROLLER READOUT
START					
STOP					

SAMPLING SYSTEM CERTIFICATION DATE: _____
 QUARTERLY RECERTIFICATION DATE: _____

C. LABORATORY INFORMATION

DATE RECEIVED: _____
 RECEIVED BY: _____
 INITIAL PRESSURE: _____
 FINAL PRESSURE: _____
 DILUTION FACTOR: _____

ANALYSIS
 GC-FID-ECD DATE: _____
 GC-MSD-SCAN DATE: _____
 GC-MSD-SIM DATE: _____

RESULTS*: _____

GC-FID-ECD: _____
 GC-MSD-SCAN: _____
 GC-MSD-SIM: _____

SIGNATURE/TITLE

* ATTACH DATA SHEETS

Exhibit 12
Transfer from Canister to
Analytical System

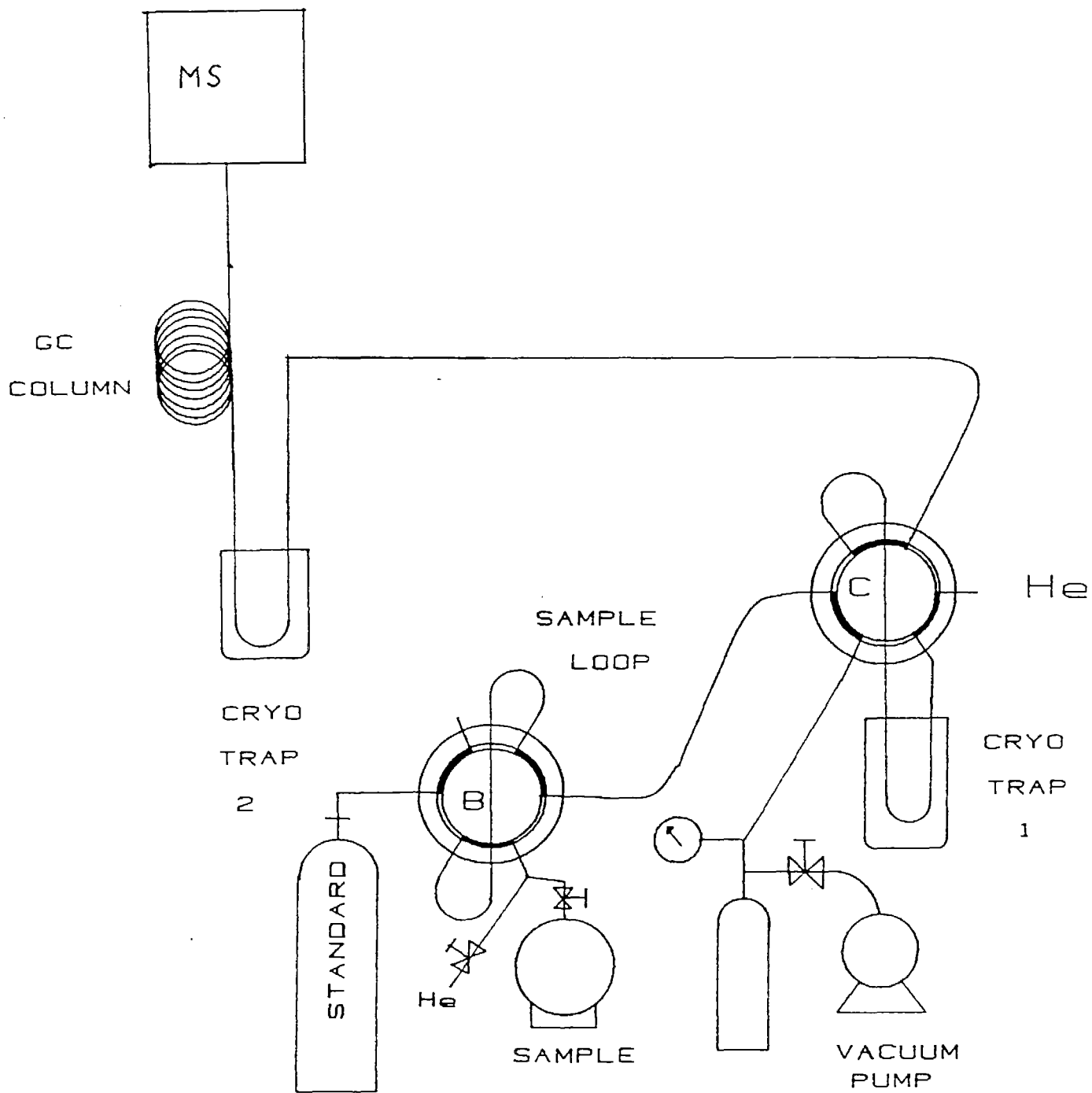
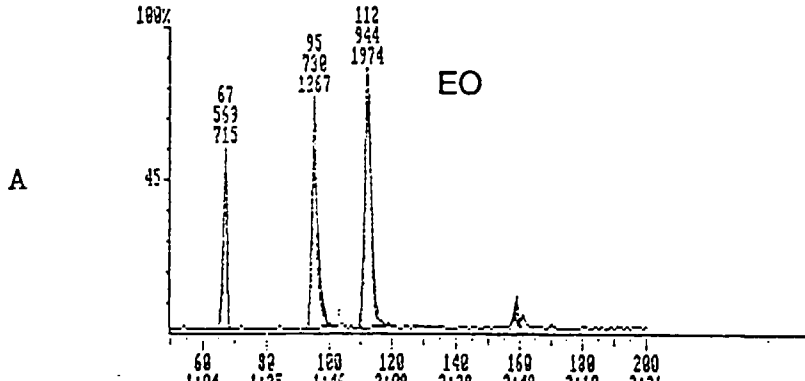

Exhibit 13
Ethylene Oxide Stability Study at 121 ppbv
1 day and 1 week

Comment: 121 PPB ETO STD, NEW CAN, RUN #4, 500 UL, 2/16/90, 15:15, MULTI=2000
 Scan Range: 50 - 200 Scan: 103 Int = 233 @ 1:59 100% = 959



Canister 1 day
 after filling
 99%

Comment: 121 PPB ETO STD, NEW CAN, RUN #1, 500 UL, 2/15/90, 16:30, MULTI=2000
 Scan Range: 50 - 200 Scan: 125 Int = 196 @ 2:13 100% = 1111

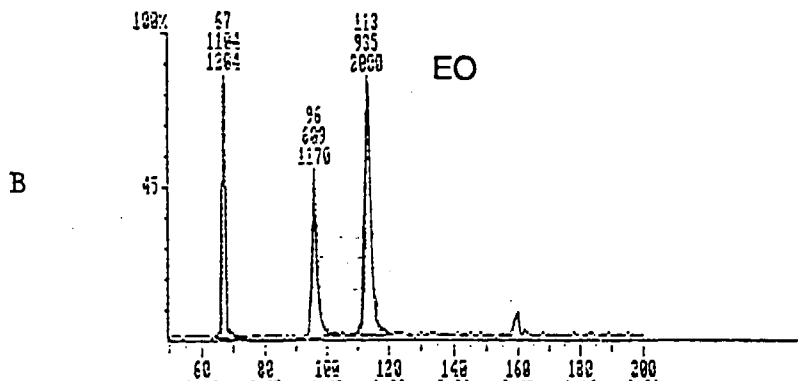

Canister immediately
 after filling

Comment: 121 PPB ETO STD WITH NEW REG, 500 UL, RUN #1, 2/23/90, MULTI=2000
 Scan Range: 50 - 200 Scan: 106 Int = 124 @ 1:53 100% = 900

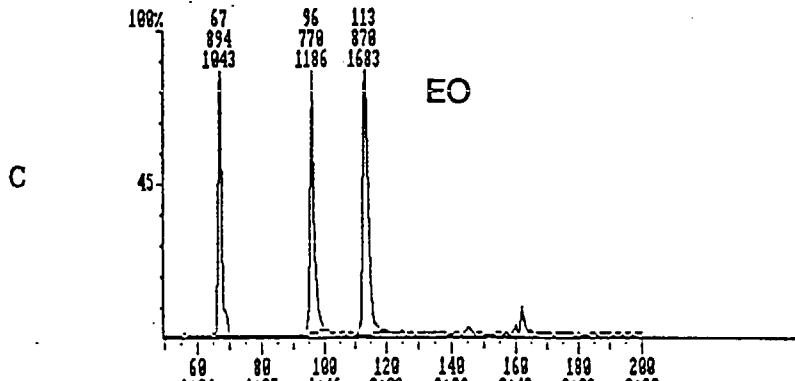

Original Standard

Comment: 121 PPB ETO STD, NEW CAN, 500 UL, RUN #1, 2/23/90, MULTI=2000
 Scan Range: 50 - 201 Scan: 125 Int = 108 @ 2:13 100% = 854

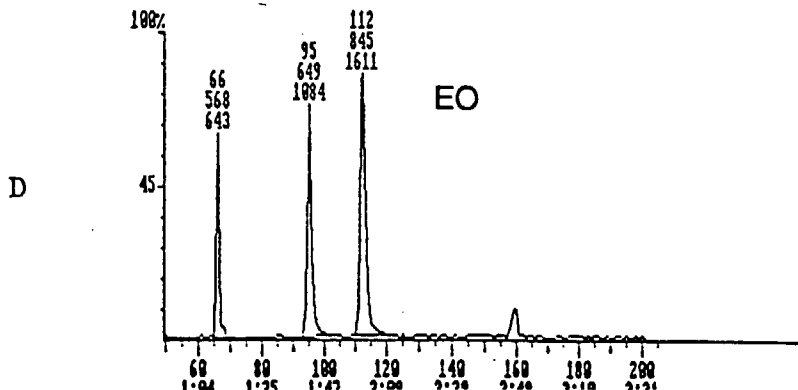

Canister after
 1 week
 96%

Peak immediately in front of EO is Acetaldehyde

Exhibit 14
Ethylene Oxide Stability at 121 ppbv
12 and 22 days

Comment: 121 PPB ETO STD CYLINDER, 500 UL, 2/27/98, MULTI=2000
 Scan Range: 50 - 200 Scan: 132 Int = 167 @ 2:21 100% = 887

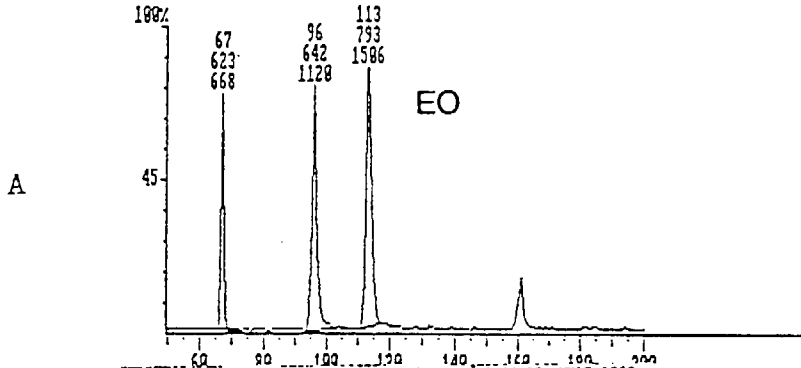

Original Standard

Comment: 121 PPB ETO STD, NEW CAN, 500 UL, 2/27/98, MULTI=2000
 Scan Range: 50 - 200 Scan: 125 Int = 139 @ 2:13 100% = 848

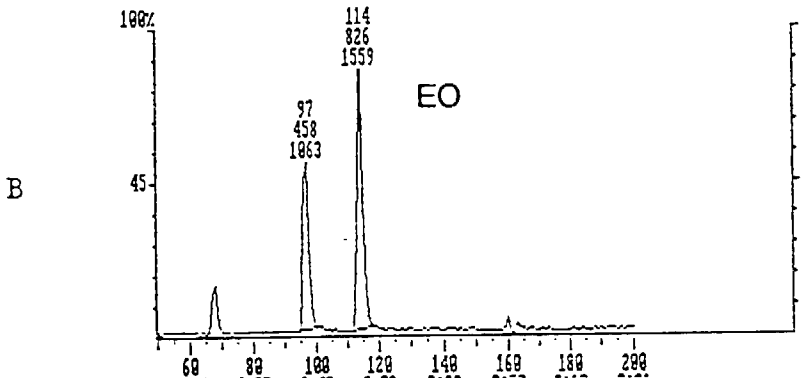

Canister 12 days
 after filling
 103%

Comment: ETO STD CYLINDER, 500 UL, RUN #1, 3/9/98, MULTI=2000
 Scan Range: 50 - 200 Scan: 184 Int = 171 @ 1:51 100% = 791

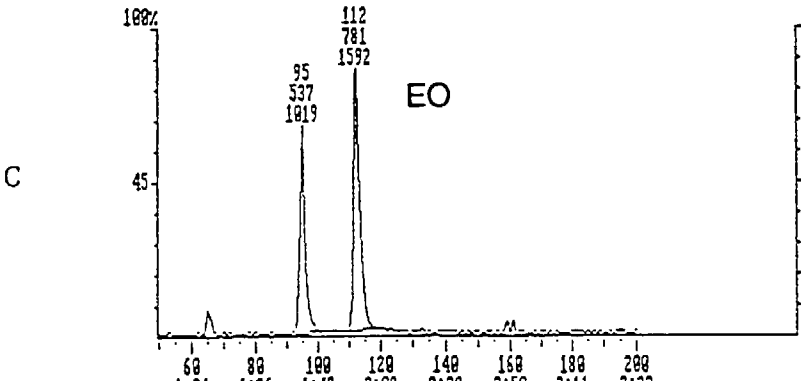

Original Standard

Comment: ETO STD, NEW CAN, 500 UL, RUN #1, 3/9/98, MULTI=2000
 Scan Range: 50 - 200 Scan: 184 Int = 136 @ 1:51 100% = 870

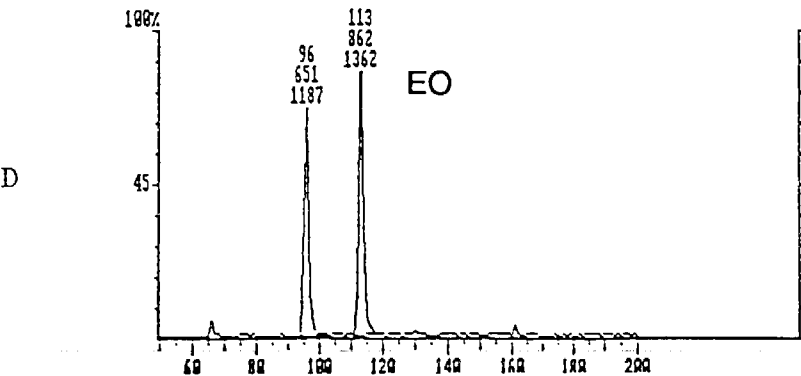

Canister 22 days
 after filling
 86%

Peak immediately in front of EO is Acetaldehyde

Exhibit 15

Diagram of Scrubber Vent
Sampling System for use with
portable GC

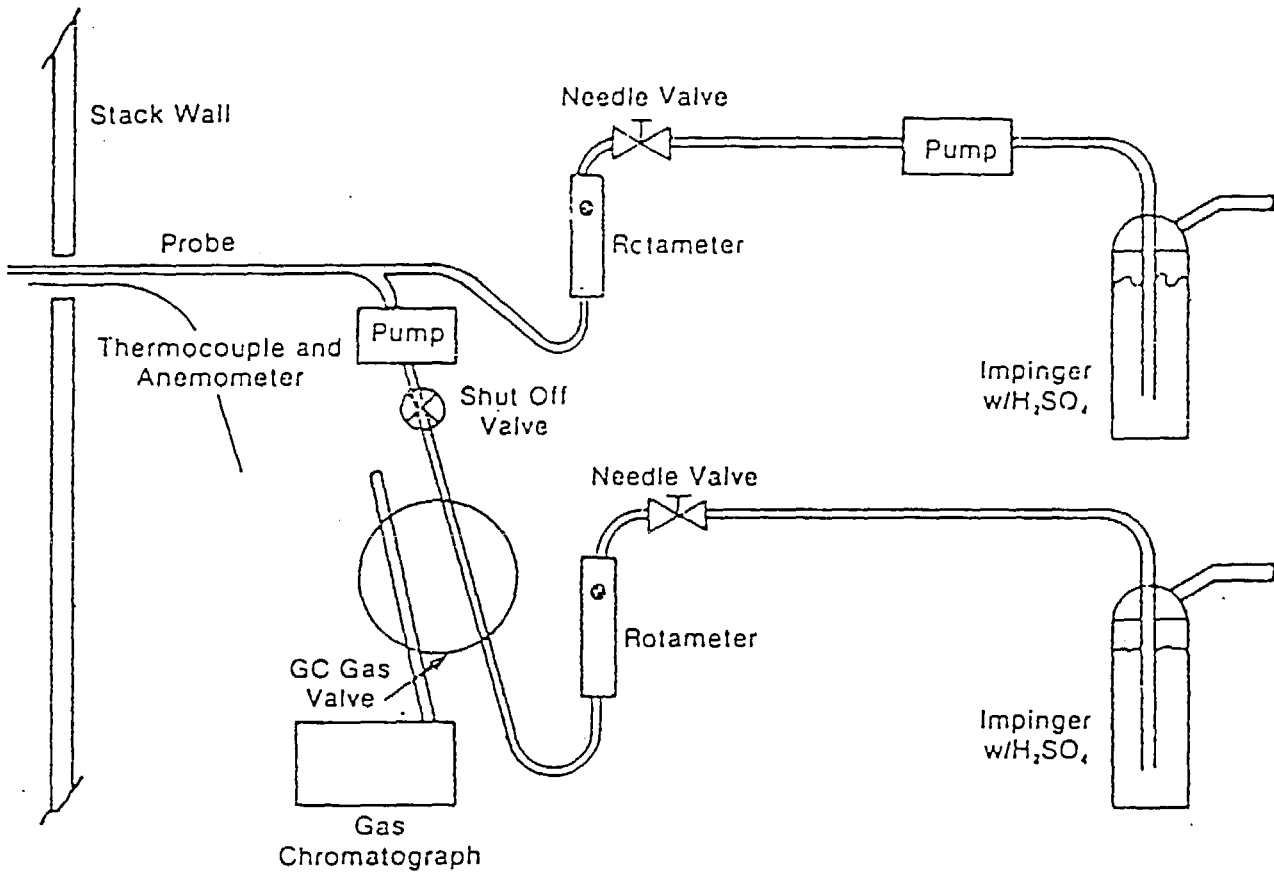
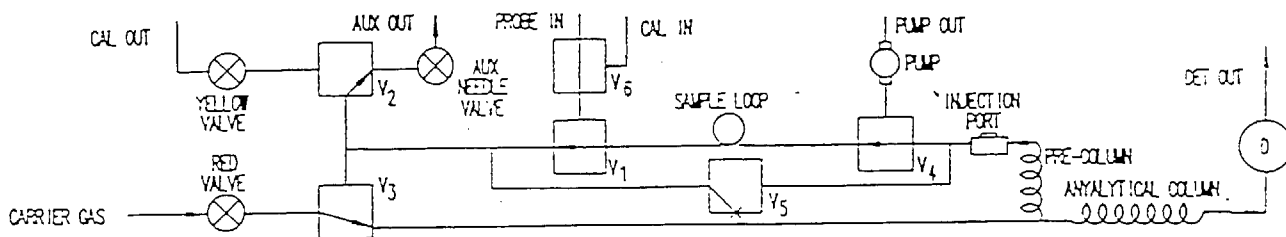
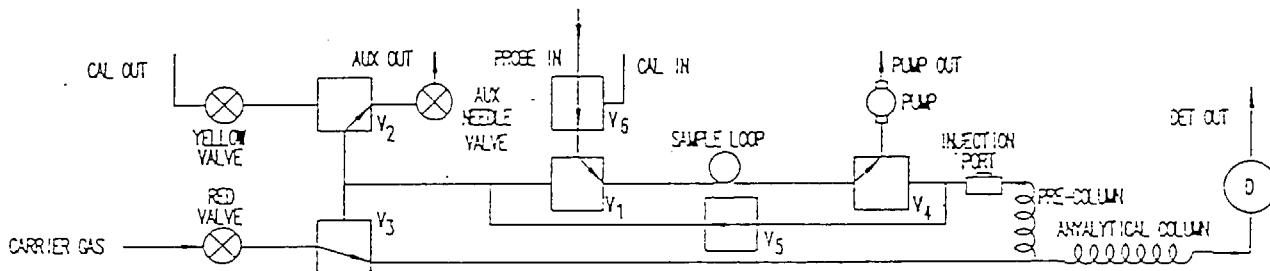

Exhibit 16

Sequence of Valve Positioning
Onsite Scrubber Vent EO Analysis



Standby/Backflush Configuration



Event 1 and Event 4 (Sample Loop Fill)

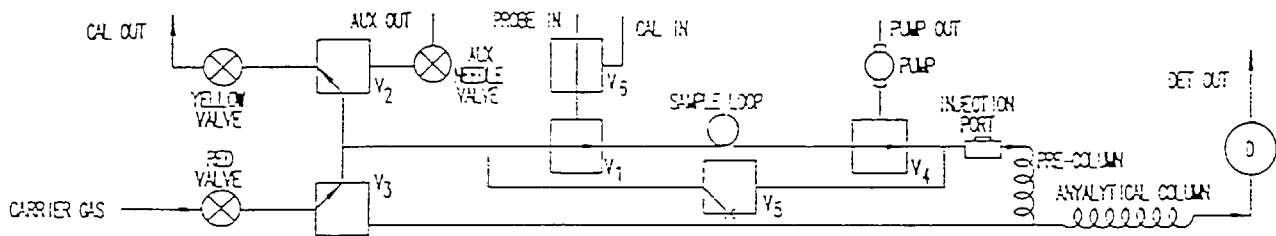

Event 3 Precolumn Foreflush

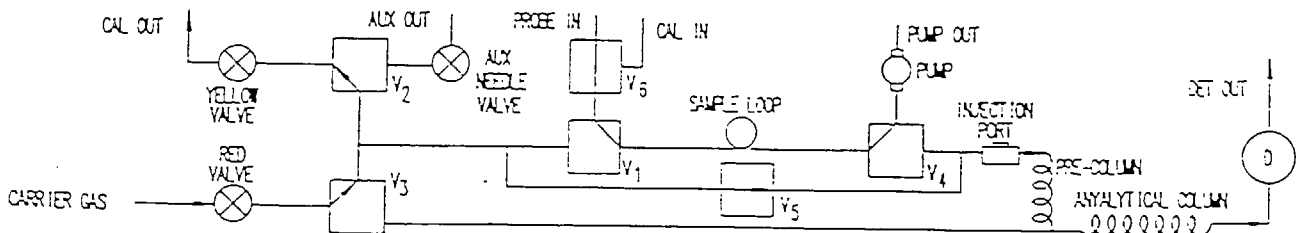

Event 5 Sample Loop Bypass

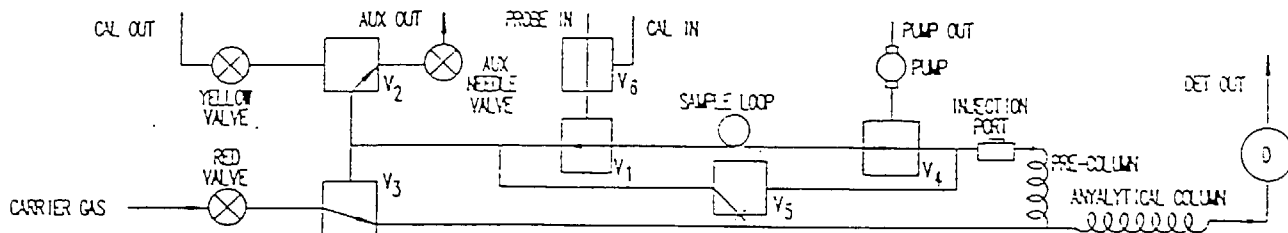

Backflush Configuration

Exhibit 17

Example Quadrupole GC/MS
Fragmentation for EO

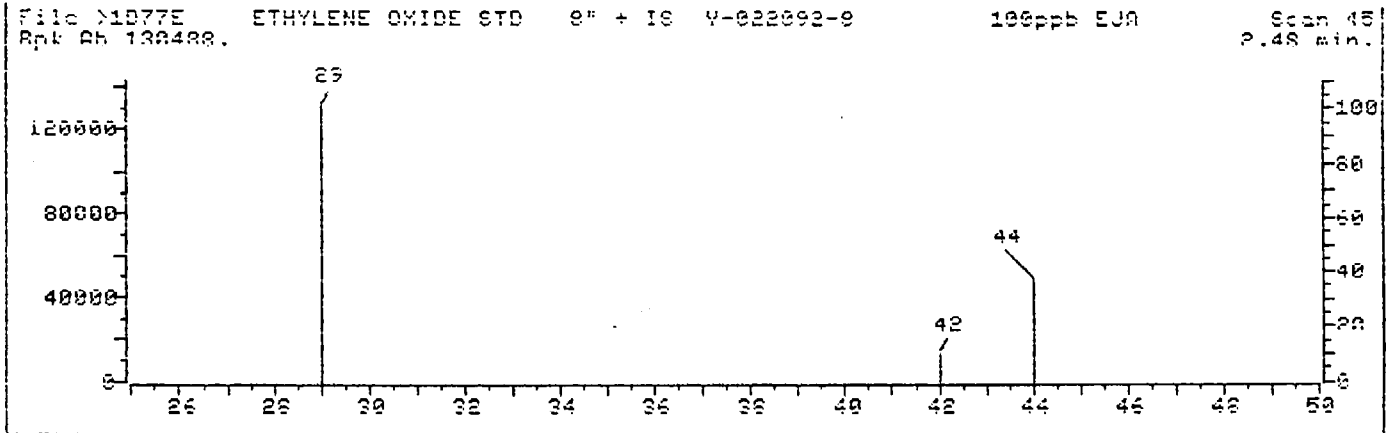

LIST OF REFERENCES

1. US EPA, Emissions Standards Division, Draft EIS, "Ethylene Oxide Emissions from Commercial Sterilization/Fumigation Operations - Background Information for Proposed Standards", March, 1988.
2. Glaser, Forest, McKee, Quave and Budde, Environmental Science and Technology, (5) 1426, (1981).
3. "Analytical Method Evaluation for Measuring Ethylene Oxide Emissions from Commercial Dilute-Acid Hydrolytic Control Units", Final Draft, Radian Corp., prepared for US EPA in Research Triangle Park, NC, Sept., 1988.
4. Niosh Manual of Analytical Methods, Method 1614, 1987.
5. Niosh Manual of Analytical Methods, Method 3702, 1987.
6. Instruction Manual for Trace Gas Analyzer HNU MODEL PI 101. HNU Systems, Newton, MA 1985.
7. "Surveillance of Ethylene Oxide Around Sterilizer Facilities Using the Photovac 10S50 Portable Microprocessor-Controlled Gas Chromatograph", Technical Bulletin #34, Photovac International, Inc., Huntington, NY, 1987.
8. "The Determination of Volatile Organic Compounds (VOCs) in Ambient Air Using SUMMA Passivated Canister Sampling and Gas
9. "Method for the Determination of Volatile Organic Compounds in Ambient Air Using Cryogenic Preconcentration Techniques and Gas Chromatography with Flame Ionization and Electron Capture Detection", Compendium Method TO-3, US EPA, April 1984.
10. Karen D. Oliver, Joachim D. Pleil and William A. McClenny, Atmospheric Environment, (20), 1403 (1986).
11. M. W. Holdren, D. L. Smith and W. A. McClenny, "Stability of Volatile Organic Compounds while stored in SUMMA Polished Stainless Steel Canisters", Final Report EPA Contact 68-02-4127 (WA-13), January 1986.
12. B. Pate, R.K.M. Jayanty, Max R. Peterson and G.F. Evans, Journal of the Air and Waste Management Association, (42), 460, (1992)



00004278



ASSET