

EFFECTS OF ACID RAIN ON PLANT MICROBIAL ASSOCIATIONS IN
CALIFORNIA

Report to the California Air Resources Board

April 13th 1984

Project No. A2 087-32

Prepared by D. Harris and E.A. Paul

Department of Plant and Soil Biology
University of California
Berkeley, California 94720

Abstract

The effects of simulated acid rain of pH 5.6 to 3.0, with ionic composition similar to that found in California, on Trifolium repens, Lupinus densiflorus and L. benthamii grown in two soils were tested. The interactions of treatment intensity, soil type, phosphorus uptake and mycorrhizal influences on growth, carbon fixation and allocation and nitrogen fixation were determined. Acidic treatments generally decreased plant growth, nodulation and nitrogenase activity. The exposure of plants to a large number of simulated rainfall conditions of shorter duration did not result in the negative growth effects. Plants adequately supplied with P, either as fertilizer or by mycorrhizal fungi, were much more resistant to conditions caused by acidic precipitation and in some cases growth increases were found. Measurements of carbon incorporation rates, beneath ground respiration and carbon allocation in established plants (10 to 12 weeks) was conducted in a specially designed growth chamber which allowed exposure of above ground plant parts to carefully controlled levels of $^{14}\text{CO}_2$. Beneath ground respiration could then be measured separately. These measurements showed only a 25% decrease due to the observed acid rain treatment and did not account for the 2-3 fold differences in plant yield. This was attributable at least in part to a decrease in sensitivity to the acid rain treatments in the older plants used for the ^{14}C studies. Internal turnover rates of carbon under acidic conditions were very high but the effect of this on long-term growth has not been clearly delineated.

Lupines and clovers were found to be acid sensitive associations that occur widely in California rangelands on soils that vary in acid sensitivity. This work has shown that further field studies of the physiological processes involved in growth and plant nutrition should lead to much better criteria regarding acidic inputs into natural environments.

Acknowledgements

We wish to give special thanks to Mr. Anthony Blake (Staff Research Associate) for excellent technical assistance both in the laboratory and the glasshouse. Financial support was provided by the California Air Resources Board, contract #A2 087-32, and the Agricultural Experiment Station of the University of California, Berkeley. The work was performed at the University under Hatch Project #4033-14.

This report was submitted in fulfillment of ARB contract #A2 087-32 "Effects of acid rain on plant microbial associations in California".

Disclaimer

The statements and conclusions in this report are those of the contractor and not necessarily those of the California Air Resources Board. The mention of commercial products, their source or their use in connection with material reported herein is not to be construed as either an actual or implied endorsement of such products.

Table of Contents

	Page Number
Abstract	1
Acknowledgements	3
Disclaimer	3
Table of Contents	4
List of Figures	6
List of Tables	7
Summary and Conclusions	9
Recommendations	13
Introduction	14
Materials and Methods	18
Soil Characterization	18
Experimental Soils	18
Acid Treatment solutions	19
Spraying	20
Plants and Fertilizer Treatments	20
Microbial Symbionts	22
Acetylene reduction Assay	22
Measurement of Mycorrhizal Infection	23
Measurement of ¹⁴ C Uptake and Allocation	23
Analyses	27
Statistical analyses	28

Results	29
Preliminary Soil Testing	29
<u>Trifolium repens</u>	33
Growth	33
Carbon uptake allocation and respiration	37
Isotopic composition of CO ₂ evolved below ground	38
Effects of mycorrhizal infection	40
<u>Lupinus benthamii</u>	42
Growth and carbon flow	42
Mycorrhizal inoculation	43
Carbon fixation, allocation and respiration	46
<u>Lupinus densiflorus</u>	49
Growth	49
Carbon fixation, allocation and respiration	50
Discussion	58
References	62
Keys to symbols and abbreviations	66

List of Figures

- Fig.1 Modified pot for measurement of below ground respiration.
- Fig. 2 Diagram of below ground gas flow system.
- Fig. 3 Flow diagram of plant labelling chamber.
- Fig. 4 Titration of Chiquito soil with pH 2.3 acid rain solution for buffering index.
- Fig. 5 Titration of Dehli Sandy Loam with pH 2.3 acid rain solution for buffering index.
- Fig. 6 Specific activity of CO₂ evolved in below ground respiration by T. repens treated with acid rain.
- Fig. 7 Specific activity of CO₂ released below ground by L. densiflorus treated with acid rain.

List of Tables

- Table 1. Summary of experimental treatments.
- Table 2. Properties of soils in preliminary survey.
- Table 3. Growth , P uptake and nitrogenase activity in T. repens grown in Dehli Sandy Loam and treated with simulated acid rain.
- Table 4. Dry weights of T. repens grown in Chiquito soil and treated with simulated acid rain.
- Table 5. Phosphorus uptake by T. repens grown in Chiquito soil and treated with simulated acid rain.
- Table 6. Concentrations of Mn and Fe in T. repens grown in Chiquito soil.
- Table 7. Carbon throughput rates and C-pool size in T. repens.
- Table 8. Distribution of ¹⁴C in T. repens.
- Table 9. Growth and nitrogenase activity in T. repens grown in Chiquito soil with or without mycorrhizal inoculation and treated with acid rain at the low dose regime.
- Table 10. Shoot P, Mn and Fe concentrations in T. repens grown in Chiquito soils with or without mycorrhizal inoculation and treated with acid rain at the low dose regime.
- Table 11. Dry weights and shoot P concentrations in L. benthamii grown in Dehli Sandy Loam and treated with simulated acid rain at a high dose regime.
- Table 12. Nitrogenase activity in L. benthamii grown in Dehli Sandy Loam and treated with simulated acid rain at a high dose regime.
- Table 13. Dry weights of L. benthamii grown for 6 weeks in Chiquito soil.
- Table 14. Phosphorus uptake by L. benthamii grown for 6 weeks in

chiquito soil.

Table 15. Manganese concentrations in L. benthamii grown for 6 weeks in chiquito soil.

Table 16. Carbon balance in L. benthamii grown in Chiquito soil and labelled for 16h with ^{14}C .

Table 17. Distributions of ^{14}C in L. benthamii grown for 6 weeks in Chiquito soil.

Table 18. Specific ^{14}C fixation rates and pool sizes in L. benthamii.

Table 19. Dry weights of L. densiflorus grown for 11 weeks in Dehli Sandy Loam and treated with simulated acid rain at a high dose regime.

Table 20. Phosphorus uptake by L. densiflorus grown for 11 weeks in Dehli Sandy Loam and treated with simulated acid rain.

Table 21. Carbon balance in L. densiflorus grown for 11 weeks in Dehli Sandy Loam.

Table 22. Distributions of ^{14}C in L. densiflorus.

Table 23. Carbon throughput rates and pool sizes in L. densiflorus grown in Dehli Sandy Loam and treated with simulated acid rain.

Table 24. Shoot dry weight and P uptake by L. densiflorus grown for 10 weeks in Dehli Sandy Loam and treated with simulated acid rain in a low dose regime.

Table 25. Concentrations of manganese and iron in shoots of L. densiflorus treated with simulated acid rain in a low dose regime.

Summary and Conclusions

The effects of simulated acid rain with ionic compositions similar to that found in California but with adjusted pH's ranging from 3.0 to 5.6 were measured on legumes grown in two California soils. Special reference was made to the interaction of the nitrogen-fixing Rhizobium and the effects of phosphorus in the commonly occurring clover (Trifolium repens) and native lupines (Lupinus densiflorus and L. benthamii). The legumes were chosen for study because of their importance in providing nitrogen to rangeland and because of previous indications that this diverse, widespread group of plants ranged in its sensitivity to acidic conditions and may thus be excellent indicator plants for future field studies on acid rain effects.

It is not possible to conduct acid rain trials on all the potentially sensitive soils in California, therefore soils for specific experiments must be carefully chosen for buffering capacity and possible toxic ions. A titration technique which determined the drop in pH (buffering index) on treatment with an acid rain-like solution and the extraction of plant available- manganese with DTPA, provided valuable information for the screening of soils. These characteristics could then be correlated with other soil properties determined in the more detailed analysis of McColl (1981). The soils from the San Joaquin experimental range, although not used in this study, represent an easily obtainable group of soils in an important experimental range area. They should be considered for further studies because of their potential sensitivity to acidic conditions and due to the fairly high amounts of DTPA extractable manganese in these soils.

The two test soils (a Dehli sandy loam from east Los Angeles and a ciquito loam from Sequoia National Forest) were low in native mycorrhizal fungi and rhizobia, this made it possible to study the effects of these organisms on the leguminous plants without having to resort to sterilization of the soils which could have altered other conditions.

There was an interaction between nitrogen fixation, phosphorus nutrition and plant and rhizobial sensitivity to applied acidity. Mycorrhizal infection in T. repens was unaffected by the acid rain treatments; it doubled plant growth by enhancing phosphorus uptake in the Chiquito soil, even though this soil appeared to have moderate P availability. Phosphorus is generally known to help plants to resist stress. The addition of phosphorus, especially to the P-deficient Dehli soil increased plant growth and reduced the sensitivity, to applied acidity, of plant processes such as carbon fixation, and greatly increased nitrogen fixation capacity even at pH's as low as 3.0.

The uptake and allocation of carbon within the test plants measured by ¹⁴C-labelling of plants at 6-10 weeks age, were only slightly affected by the acidity of the treatments, indicating that other factors were responsible for the effects on plant growth. It was of great interest, that although net CO₂ fixation rates and carbon distribution were not greatly affected, the turnover rates of the ¹⁴C compounds within the plant (as measured by specific activity) were much increased by treatment at pH 3.0. The exact inter-relation between allocation and turnover rate is not known. However, this could be an important plant response to increased acidity that should be further investigated.

The inability of native mycorrhizal fungi, normally present in

grasslands to infect lupins was unexpected; although there have been two reports in the literature that this occurs with other lupin species. A limited field survey indicate that the lupins were not commonly infected under field conditions. The absence of mycorrhiza on the lupins made them excellent subjects to investigate the interaction of acid rain and phosphorus.

Test plants were grown in pots in a glasshouse, at full sunlight since legumes have high requirements for light intensity. Acid rain treatments were applied in a specially constructed spray chamber and dosage was controlled by the duration and frequency of application at a constant rate. Two treatment regimes were used representing relatively infrequent but heavy rainfall and frequent light rain. The second treatment which wetted the plant foliage but did not saturate the soil resulted in fewer deleterious and some positive effects on plant growth, indicating that both the duration and intensity of the rainfall are important and must be studied under field conditions.

High concentrations of manganese in plant tissues were found under a number of conditions, especially where acid treatments were applied. There were interactions between manganese and iron uptake and mycorrhizal infection but these could not be adequately characterized in this short series of experiments.

There was considerable evidence to suggest that the inhibitory effects of the acid rain treatments were greatest at early stages of plant growth. The carbon flow measurements on both T. repens and L. densiflorus showed that at 10 - 12 weeks, despite their smaller size, the specific rates of carbon uptake (and thus growth rates) in the acid treated

plants equalled or exceeded those of the pH 5.6 controls. This catch-up effect or the ability of plants to overcome some of the deleterious effects of applied acidity is also shown by the fact that seedlings could only be established if acid rain treatments were delayed for 3-4 weeks after planting. These observations together with those on the effects of duration of individual rainfall events, indicate that in the field, the distribution in time as well as overall amounts of acid rain can be important in determining effects.

Recommendations

1. Legumes are considered to be excellent plants for further studies of acid rain, especially for work under field conditions. The wide diversity of the lupines, the fact that they are easily recognizable, and their importance in nitrogen fixation indicates that field studies should be done on the effects of acid rain on lupin growth and nitrogen fixation at the sites where intensive acid rain studies are being conducted.

2. The interaction of plant phosphorus uptake with acid rain requires further work. The possible amelioration of acidic effects with phosphorus applications is well worth considering. Studies which do not take the possibility of phosphorus interactions into account may be overlooking an important component of the normal plant-microbial growth cycle.

3. The ^{14}C uptake studies have shown the important information that carbon uptake and allocation are not greatly affected by acid rain in established plants, but that C-turnover rates are influenced by acidity. Further physiological studies of lupins and clover at various growth stages are required. Carbon allocation studies should not have as much priority as phosphorus mycorrhizal legume interactions relative to phosphorus uptake and nitrogen fixation.

4. The frequency and duration of simulated rainfall had major effects on the leguminous rhizobial mycorrhizal associations. These effects should be studied further under field and laboratory conditions

Introduction

The demonstration of significant amounts of acid rain in California together with the fact that acid rain has the potential for altering plant productivity (McColl, 1981) leads to major questions concerning the sensitivity of California's rangelands and forested areas to this phenomenon. Associations of plants and bacteria in legumes such as lupins and clovers and non-legumes such as ceanothus, are the major suppliers of nitrogen to most of California's uplands. The 8.8 million hectares (20 million acres) of range soils depend for their productivity on the N inputs from sporadic growth flushes of legumes such as lupins and clovers under appropriate environmental conditions.

The leguminous association should be a more sensitive indicator of environmental effects than soil nitrogen and carbon transformations carried out by the general soil microflora. The success of the legume - Rhizobium symbiosis depends not only on the productivity of the plant per se, but also on its ability to supply the energy requirements of the microbial symbionts in the form of translocated photosynthate. This increases the potential vulnerability of the system both to plant mediated effects of acidic deposition on photosynthetic capacity as well as on the survival and symbiotic potential of the microorganisms.

Firestone et al (1984) found that short term exposures (three months) to acidic rain increased N₂ fixation levels in clover (Trifolium repens) grown in a California soil. However, in longer exposure periods, the N₂-fixing capacity of clover was reduced by acidic rain with a pH of 3.0. The application of acidic rain at pH 3.2 for 1 to 9 weeks also caused

decreases in nodulation in kidney beans in experiments conducted by Shriner and Johnson (1981). McLaughlin *et al* (1982) upon exposing bush beans (*Phaseolus vulgaris*) to simulated acid rain found altered patterns of carbon allocation in both roots and shoots. There were greater respiratory losses and decreased retention of photosynthate in leaves. The pH-sensitive steps in nodulation and symbiotic N₂ fixation were found to be 10 times as sensitive to acidity as either bacterial growth or root growth alone. The reason for this sensitivity is not known. One possible mechanism is the toxicity of heavy metals (Kliewer, 1961; Brener, 1966).

Nitrogen-fixing nodules have a much higher phosphorus requirement than the rest of the plant and a direct relationship between the activity of mycorrhizal fungi and N₂ fixation has been noted (Tinker, 1982; Paul and Kucey, 1981). Very little is known about the effects of acid rain on the vesicular-arbuscular mycorrhizae (VAM) which forms the mycorrhizal associations found in N₂-fixing plants.

Mycorrhizal fungi play an important role in phosphorus uptake by leguminous root systems such as clovers which have a minimal number of root hairs. They have also been observed in this laboratory to ameliorate manganese toxicity in faba beans. There have been reports that certain of the lupins have roots with exceptionally well developed root hair systems and therefore do not require mycorrhizae for phosphorus uptake (Trinick, 1977; Gardner and Parberry, 1982). However, the mycorrhiza-lupin interaction in Californian species has not been determined.

California has a large number of soils where the potential effects of acid rain on plant growth and soil mineral leaching should be investigated. However, it is impossible to conduct experiments ascertaining the effects

of acid deposition on all of the sensitive soil and plant microbial associations. We must obtain information on the effects of acidity relative to both the positive and negative responses of sensitive plant types as well as the symbiotic organisms such as mycorrhiza and rhizobia. Initially this work can be conducted in the laboratory but the major aim must be to obtain information that can be extended to in-situ measurements under field conditions.

The establishment of adequate guidelines for assessment of the effects of acid precipitation and the development of field monitoring sites will require the identification of suitable indicator plants that are fairly responsive to environmental conditions and range in sensitivity to acidity and soil chemical factors. The lupins and clovers could provide such a combination. Lupins are widely distributed in California and different species have different tolerances to soil acidity (O'Leary, 1982). They therefore have the potential for being readily recognised indicators of acidity. The measurement of growth, nitrogen fixation, carbon allocation and mycorrhizal interactions of these plants should lead to a better understanding of the responses of these important components of our natural habitat. It should also help to establish the criteria for the future establishment of field monitoring programs to measure the long term responses to acid rain.

This study tested a series of soils, representing areas from east of Los Angeles to northeast of San Francisco, for buffering capacity and potential sensitivity to acid rainfall. The physiological interactions of three common species of legumes with their micro-symbionts and simulated acid rainfall at a range of pH values were studied under

greenhouse conditions in two of these soils

Materials and Methods

Soil Characterization

Samples of surface soils from a number of sites in California, ranging in altitude up to 8000 ft were collected. Duplicate samples of the soils (10 g) were mixed with 20 ml water and stirred on a magnetic stirrer. To one of the duplicates, simulated acid rain solution (see below) was added at a constant rate of 2.5 ml/h for 4 h using a Fisher automatic titrator and the pH of the soil slurry recorded. The other duplicate was similarly stirred but received no acid addition. The difference in the pH of the two samples after 4h was used as an index of the buffering capacity of the soil.

The extractable manganese contents of the soils were determined by DTPA (Diethylenetriaminepentaacetic acid) extraction. A 1:2 (w:v) slurry in 0.005M DTPA, 0.01M CaCl_2 , 0.1M triethanolamine, adjusted to pH 7.3 was shaken for 2h. The Mn concentration in a filtrate of the slurry was then measured by Atomic Absorption spectrometry.

The suitability of the test soils for growth of lupins and clover in pots was assessed in preliminary growth studies. The test plants were grown for 6 weeks and watered with 1/2 strength Hoagland's solution either with or without phosphorus.

Experimental soils

After the preliminary tests, two soils were selected for further studies. A Dehli sandy loam from the desert area east of Los Angeles had an original pH of 8.4, this high pH was considered atypical of the

collection site (Jarrell, personal communication) and the pH was adjusted before use by leaching pots containing 2kg of the soil with 550 ml of simulated acid rain solution at pH 2.3 (an addition of 1.38 meq[H⁺] / kg soil). The Dehli soil had a cation exchange capacity (CEC) of 11.6 meq/100g after pH adjustment. A second soil of the Chiquito series, a young, coarse granitic soil was collected from the Badger Pass area of the Sequoia National Park at an altitude of about 8000'. This soil had an initial pH of 4.95 which was not adjusted and a CEC of 22.4 meq/100g.

The bicarbonate extractable P concentrations of the soils were determined colorimetrically, by the ammonium molybdate method on a Lachat flow injection autoanalyser, after extraction for 30 min with 0.5M NaHCO₃ at pH 8.5. The concentrations of extractable Mn and P in the Dehli soil were 2.25 ppm and 4.2 ppm, those of the Chiquito soil 3.2 ppm Mn and 13.8 ppm P.

Acid treatment solutions

Four treatment solutions were used, each comprised a basal salts solution (McColl, 1981), designed both to simulate the ionic composition of acid rain in California and to reduce the possibility of nutrient effects due to the ionic composition of the acid solutions.

Ionic composition of basal salts solution

Species	Mg ²⁺	Ca ²⁺	NH ₄ ⁺	K ⁺	Cl ⁻	SO ₄ ²⁻
Concentration	6	7	15	1.5	15	6
(m eq/l)						

Appropriate amounts of a mixed acid (0.6N HNO₃, 0.04N H₂SO₄) were added to the basal salts solution to obtain solutions of pH 5.6, 4.5, 4.0 and 3.0.

Bulk solutions were prepared in 120 l plastic containers and the pH was retested before each use.

Spraying

Pots were arranged in 4x4 arrays on moveable tables c. 1m square. Spraying was performed in a plastic lined chamber which held one table. The treatment solutions were pumped through a single stainless steel nozzle which delivered a square spray pattern. The nozzle was adjusted to deliver an even deposition over the area of the table. Delivery rate was constant at 29 ml/15 cm pot/min. Dose was determined by the duration and frequency of spraying. Two treatment regimes were used, a 10 min spray which saturated the water- holding capacity of the soils and a 2 min spray which thoroughly wetted the plant foliage but did not saturate the soil. Pots were sprayed as frequently as their drying and the need to add fertilizer solutions allowed; this was usually twice per week at the high dose and three times per week at the low dose. After each spray treatment, the array of plants on each table was rotated to compensate for edge effects in the spray pattern.

Seedlings seldom survived the spray treatments so spraying was delayed for 3-4 weeks after planting to allow establishment. Spray and other treatments are summarised in Table 1.

Plants and Fertilizer treatments

Two species of lupines, Lupinus densiflorus and L. benthamii and white clover, Trifolium repens were tested. Plants were grown in 15 cm diam. pots in a glasshouse from May to December 1983. Minimum glasshouse temperature was maintained at 20C, maximum temperatures varied up to

Table 1. Summary of Experimental Treatments

<u>Plant sp.</u>	<u>Symbionts</u> *	<u>Soil</u>	<u>P-</u> <u>addition</u>	<u>Growth</u> <u>Period</u>	<u>Spray Treatments</u>			
					<u>Begun</u>	<u>Number</u>	<u>Duration</u> (min)	<u>Total Dose</u> cm
<u>T. repens</u>	<u>Rhiz</u>	DSL	+	10 wk	3 wk	10	10	16.8
<u>T. repens</u>	<u>Rhiz</u>	C	+	10 wk	3 wk	7	10	11.2
<u>T. repens</u>	<u>Rhiz+Vam</u>	C	-	10 wk	3 wk	23	2	7.2
<u>L. benthamii</u>	<u>Rhiz</u>	DSL	±	10 wk	3 wk	10	10	16.8
<u>L. benthamii</u>	<u>Rhiz</u>	C	+	6 wk	3 wk	6	10	9.5
<u>L. densiflorus</u>		DSL	±	10 wk	3 wk	10	10	16.8
<u>L. densiflorus</u>		DSL	±	10 wk	3 wk	19	2	6.0

*Inoculation at planting; DSL = Dehli Sandy Loam; C = Chiquito Soil

35C, in hot weather the plants were shaded with muslin to keep soil temperatures below 40C.

Plants were watered with a modified 1/2 strength Hoagland's solution before and between acid treatments. The solution contained a reduced N concentration (2.65mM) and was prepared with or without P (0.5 mM) but was otherwise complete in major and minor nutrient elements. Plants inoculated with vesicular-arbuscular mycorrhizal fungi (VAM) received the P- solution, those not inoculated were given P+.

Microbial symbionts

L. benthamii was inoculated with Rhizobium lupinii isolated from L. bicolor and kindly supplied by L. Harding (Fresno State University). L. repens was inoculated with a commercial peat inoculum of R. trifolii.

Isolates of VAM fungi, Glomus fasciculatus and G. mosseae, were maintained in pot culture on onions in a Josephine soil that had been sterilized with ethylene oxide. Inoculum consisting of 10g of a mixture of soil and chopped roots was applied as a layer 5cm below the soil surface before seeding. Control plants were given a similar mixture derived from onions without mycorrhizae. The incidence of indigenous Rhizobium and VAM in the Chiquito and Dehli soils was low, this made soil sterilization unnecessary.

Acetylene reduction assay for nitrogenase activity

The shoots of test plants were removed and the roots shaken free of loose soil. The entire root system was placed in a 125 ml flask and sealed with a serum cap. Ten ml of air was removed and replaced with acetylene. The flasks were incubated for 1h at 25C, when 1ml gas samples were removed for assay. Ethylene was measured by gas chromatography using a

1.5 m column of Poropak N at 120C and a flame ionization detector.

Measurement of mycorrhizal infection

Roots were separated from soil by picking and dry sieving, then washed to remove most adherent soil particles. The root system was cut into c. 1 cm pieces and mixed. Excess water was removed by pressing the roots between paper towels and the root fresh weight was determined. A sample of the roots was removed and weighed. The remaining roots were dried at 60C. The sampled roots were cleared in 10% KOH and stained in 0.3% trypan blue in lactophenol by the method of Phillips and Hayman (1970). Percentage infection was assessed by the line intercept method (Ambler and Young, 1977) using a dissection microscope at x50 magnification.

Measurement of $^{14}\text{CO}_2$ uptake and allocation

Plant labelling chamber

The apparatus for the measurement of carbon flow in intact plants consisted of two main parts and was an improvement of a chamber described by Kucey (1980). The design of the chamber allowed the above ground plant parts to be exposed to $^{14}\text{CO}_2$ at a controlled concentration of 350 ppm and a specific activity of 200 $\mu\text{Ci/gC}$ and these were hermetically separated from the below ground parts. All CO_2 evolved by respiration below ground could be separately trapped.

The soil-root system was enclosed in a modified pot with a sealed base. A plastic lid was sealed into the top of the pot and around the stem of the plant with an acrylic latex caulk. The lid was fitted with swagelock connections for gas inlet and outlet and for the introduction of

water (Fig.1). Air from which the CO₂ had been removed by passage through 0.5M NaOH was pumped through the pots, the effluent air was again passed through NaOH to trap CO₂ evolved in each pot (Fig. 2).

The pots were enclosed in a shallow metal tank (25 x 70 cm diam.) with a plastic film canopy (Propafilm C) which held 10 plants. The enclosed air was recirculated past a Geiger Muller tube. The output from the GM tube fed into a ratemeter fitted with a variable set point and used to control the operation of a solenoid valve which allowed the addition of NaH¹⁴C₃O₃ (1M, 200 μCi/gC) to a reservoir of excess lactic acid in the air circuit (Fig.3). This enabled the control of ¹⁴CO₂ concentration within the canopy. The labelling chamber was operated at a constant temperature of 25C in a plant growth room with a 16h daylength at 450 μEm⁻²sec⁻¹. The growth room temperature was set to 21C during photoperiods to compensate for the 4C rise in temperature within the canopy due to the "greenhouse effect".

Labelling procedure

One week before labelling, pots were watered to 80% of field capacity (moisture contents of 19% and 23% for the Chiquito and Dehli soils) and the lids sealed in place. The plants in the sealed pots were allowed to equilibrate in the chamber and watered to weight each day to determine daily water loss. The seals were tested to a positive pressure of 20 cm water and repaired if necessary. During the 8h dark period prior to the introduction of ¹⁴CO₂, the above ground atmosphere was purged of ¹²CO₂ by recirculating the air through 0.5M NaOH, the below ground atmosphere was similarly purged with CO₂-free air.

At the beginning of the photoperiod, ¹⁴CO₂ was introduced and the

Fig. 1 Modified pot for measurement of below ground respiration.

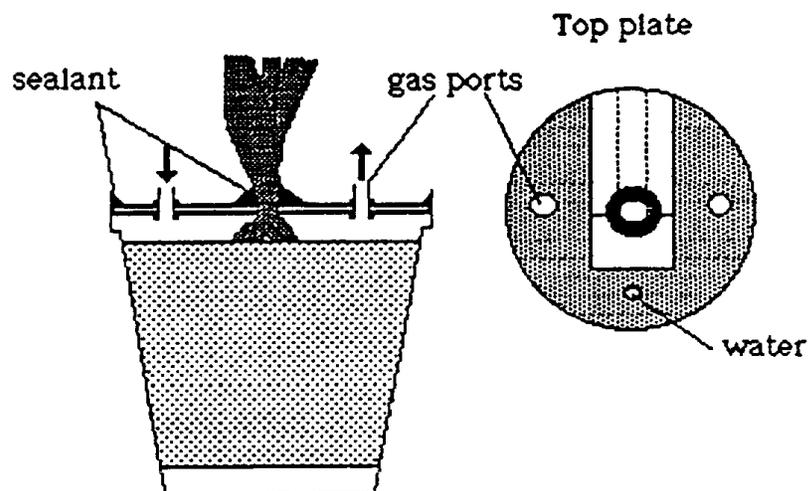

Fig. 2 Diagram of below ground gas flow system.
(only 4 of 10 pots shown)

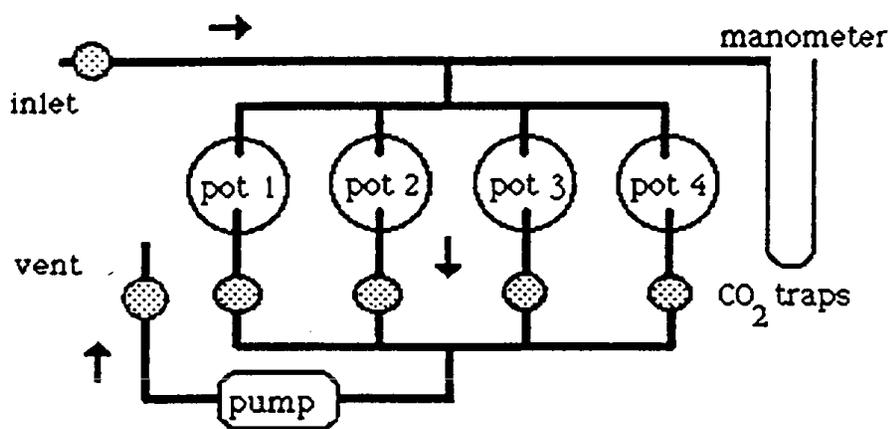
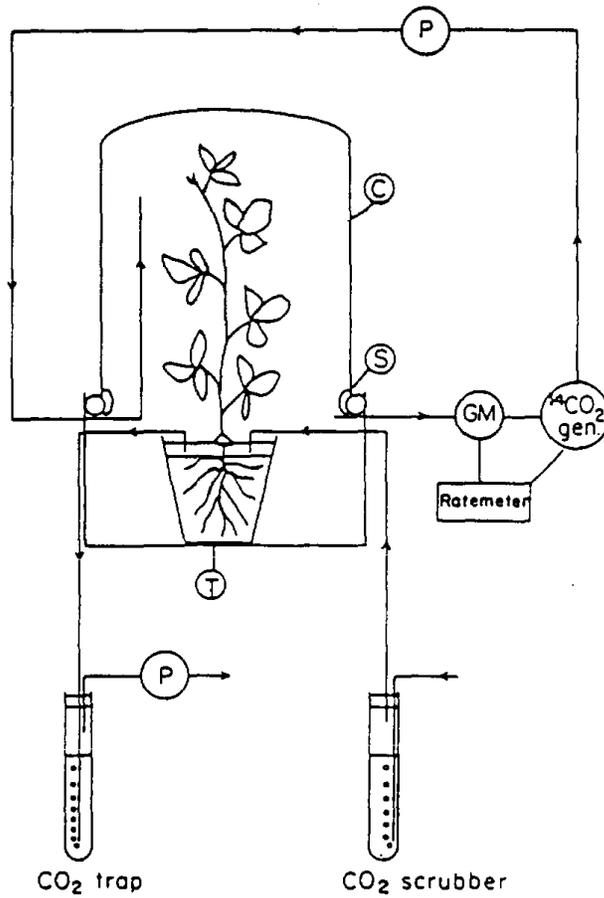

Fig. 3.

FLOW DIAGRAM OF PLANT LABELLING CHAMBER



- P = pump C = "Propafilm C" canopy
- GM = Geiger Muller tube S = bicycle tire gas seal
- T = Sheet metal tank

concentration maintained at 350 ppm \pm 20 ppm for the duration of the pulse (normally 16h). The $^{14}\text{CO}_2$ concentration was tested at 1h intervals by gas chromatography using a Poropak N column at 50C and a thermal conductivity detector, and adjusted at the ratemeter if necessary.

At the end of the labelling period, the $^{14}\text{CO}_2$ was removed and that evolved by shoot respiration in the dark was trapped in NaOH solution by pumping air through the canopy. During subsequent photoperiods the canopy was removed to allow equilibration at atmospheric CO_2 concentration. The possible evolution of $^{14}\text{CO}_2$ by the shoots in the light could not be measured. Since the canopy atmosphere was common to all plants, their individual contributions to the CO_2 evolved in night respiration by the shoots could not be individually determined but the overall amount was measured.

The CO_2 evolved below ground was continuously collected throughout the labelling and subsequent chase period (120h) for each plant/soil system. The CO_2 traps were changed at 4h intervals for the first 48h and at 6h intervals thereafter so that the time-course of $^{14}\text{CO}_2$ evolution could be determined.

Water was added to each pot daily according to the previously determined requirement.

The chase period with $^{12}\text{CO}_2$ was continued after labelling to allow the rate of evolution of $^{14}\text{CO}_2$ below ground to decline until it was replaced by $^{12}\text{CO}_2$. The plants were then harvested, separated into component parts and analysed for dry weight, P, Mn, Fe and ^{14}C

Analyses

Plant material was dried at 60C, weighed and ground to <40 mesh.

Triplicate samples (5mg) were weighed into scintillation vials and digested in 1M hyamine hydroxide in methanol for 24h at 60C. After addition of 0.5ml glacial acetic acid to suppress chemoluminescence (Fuchs and DeVries, 1972) and 10ml Scintiverse II, disintegrations were counted in a Beckmann liquid scintillation counter using internal standards for quench correction.

Carbon was released from soils by wet oxidation of 1g samples with a mixture of H_2SO_4 and H_3PO_4 (25ml 50:50) and $K_2Cr_2O_7$ (1g) at boiling point, and trapped in 0.2M NaOH. Total CO_2 in NaOH was determined by titration with HCl after precipitation of CO_3^{--} with $BaCl_2$. Liquid scintillation counting on 1ml samples mixed with 10ml Scintiverse E was used to measure the ^{14}C content of NaOH and of root washings.

Phosphorus, manganese and iron were measured in perchloric acid digests of the plant material, P by color reaction with ammonium molybdate in a Lachat flow injection autoanalyser and the metals by Atomic Absorption spectrometry.

Statistical analyses

Treatment effects were evaluated using 1 or 2 way analysis of variance to fit a general linear model by the method of least squares. Where treatment effects were significant, individual means were compared using univariate matrices to compute an error sum of squares. Probability values for treatment effects and interactions are shown in the form, "P(effect) probability". Individual means, where significantly different at $P < 0.05$ are shown with differing superscripted letters.

Results

Preliminary soil testing

Samples from 9 sites were collected and tested for pH, buffering capacity and extractable manganese concentration. Soil pH varied between 4.95 for Chiquito and a San Joaquin soil to pH 8.4 for the Dehli Sandy Loam (Table 1). On the basis of titration with simulated acid rain at pH 2.3, the Josephine soils showed least sensitivity to change in pH and Dehli Sandy Loam and the soils from San Joaquin experiment range the highest sensitivity. Titration curves for the Badger Pass Chiquito and Dehli Sandy Loam soils are shown in Figs. 4 & 5.

Extractable Mn concentrations in the Kings Canyon Chiquito soils encompassed the the entire range of sample soils, from 1.3 to >20 ppm (Table 1). However, soil collection at the Kings Canyon sites was discouraged due to their fragility and the amenity value of the proposed sampling area.

Preliminary tests with lupines and clover showed that the Dehli Sandy Loam and Chiquito soil from Badger Pass though relatively low in extractable Mn were among the least buffered of the test soils. Other soils were either texturally unsuited to pot trials and would have required dilution with sand (Auburn, Blodgett) or did not readily support the growth of the test plants (Redding, Blodgett). The Blodgett soils were notable for their extreme phosphorus fixing capacity. The Dehli sandy loam represented a neutral to slightly basic soil from lowland desert areas whereas the Chiquito represented upper elevation sites thought to be sensitive to acid rain. These two soils were therefore utilized for further

growth and carbon translocation studies with clover and lupines.

Table 2. Properties of soils in preliminary survey

Soil Series	Site	pH	Buffering Index	DTPA extractable Mn (ppm)
Musick	Blodgett			
	3-1	5.60	0.90	4.8
	3-1A	6.00	1.05	12.7
	3-2	5.70	1.00	-
	San Joaquin			
	1	5.80	1.35	4.8
	2	6.00	1.30	8.2
Chiquito	3	4.95	1.85	12.9
	Kings Canyon			
	5-1	5.2	1.60	>20
	7-1	6.0	0.60	18.7
Josephine	7-4	7.0	0.90	1.30
	Auburn			
	1	6.9	0.8	-
	8	7.1	0.3	-
Dehli Sandy Loam acidified	9	6.9	0.4	-
	Los Angeles			
Chiquito	A	8.4	1.80	2.25
	B	6.8	1.25	2.25
Kanaka Diamond Springs	Badger Pass			
	1	4.95	1.35	3.20
Josephine	Redding			
	1	5.00	-	13.5
Josephine	4	4.70	-	67.0
	Hopland	5.6	-	-

Numbers for sampling sites refer to different samples collected within the primary site, except for the Dehli Sandy Loam where A and B are before and after pH adjustment.

Fig. 4. Titration of Chiquito soil with pH 2.3 acid rain solution for determination of buffering index.

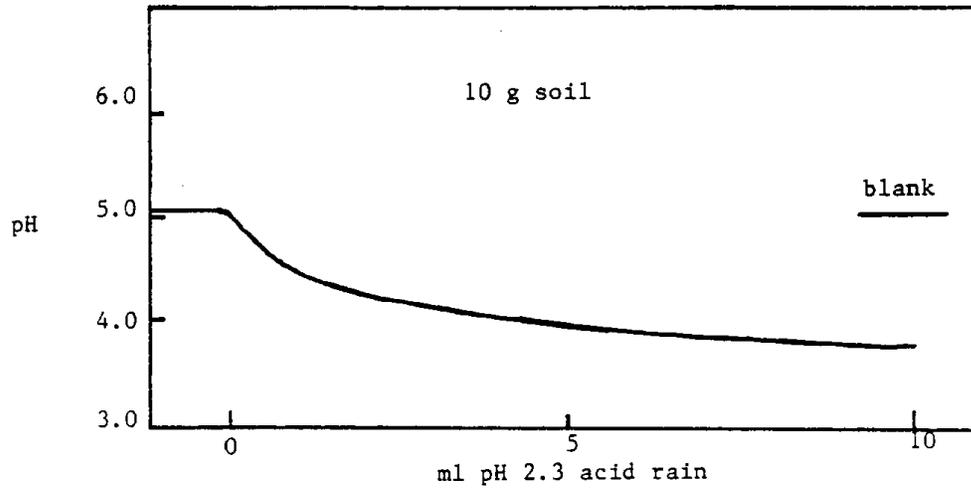

_____ soil pH

Blank stirred in H₂O without acid addition.

Fig. 5. Titration of Delhi Sandy Loam with pH 2.3 acid rain solution for buffering index.

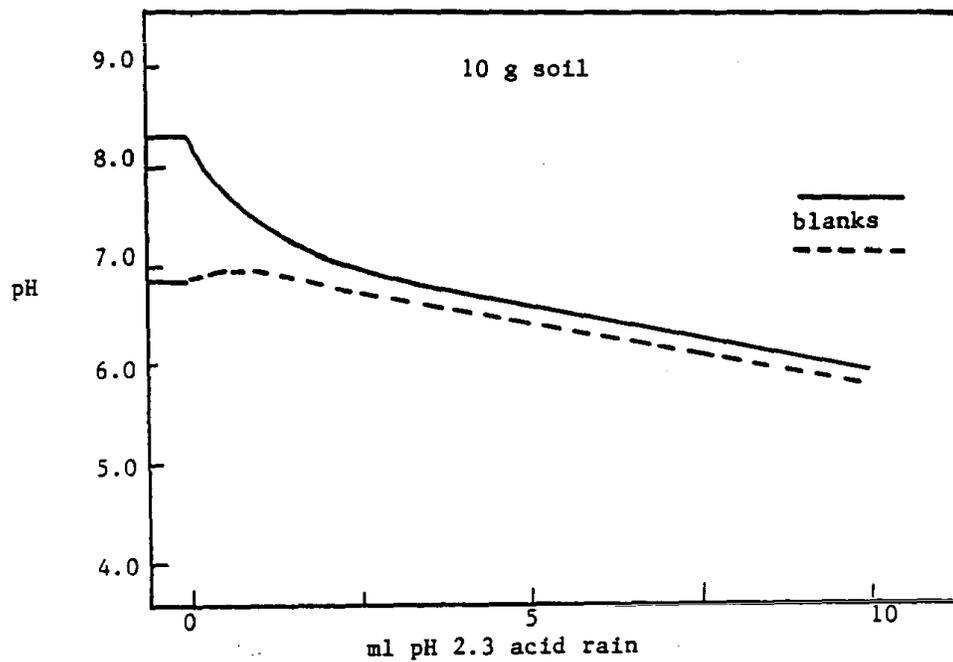

— unacidified native soil
- - - soil after pH adjustment with 275 ml/kg pH 2.3 acid rain

Blanks stirred in H₂O without addition of acid.

Growth of *Trifolium repens*

The effects of applying 1.6 cm of simulated acid rainfall in a 10 min spray interval twice per week (high dose regime) on the growth, P uptake and nodulation by Rhizobium in plants uninfected by mycorrhizal fungi were tested in Dehli Sandy Loam. Plants were grown for 10 weeks and received a total of 2580 ml/pot (equivalent to 16.8 cm rainfall) of the treatment solutions.

Table 3. Growth, P uptake and nitrogenase activity in *T. repens* grown in Dehli Sandy Loam and treated with simulated acid rain.

pH	P	Shoot dw (g)	Shoot P (ppm)	C ₂ H ₄ (μ l/h)
5.6	+	4.26 ^a	1941 ^a	22.0
4.5	+	1.68 ^{bc}	2370 ^b	3.1
4.0	+	2.17 ^b	2345 ^b	1.47
3.0	+	2.66 ^b	2900 ^c	0.83
5.6	-	1.16 ^c	1558 ^a	0.74
4.5	-	1.17 ^c	1044 ^d	0
4.0	-	1.35 ^c	1482 ^d	0.09
3.0	-	0.52 ^d	1601 ^a	0
\pm SEM		0.21	80	
P(pH)		0.003	0.004	
P(P)		0.049	0.011	
P(pH x P)		0.046	0.310	

Values are means of 6 replicates

The acidity of the treatment solutions affected plant growth compared to the control (pH 5.6). When the plants were supplied with P, the lowest yield was obtained at pH 4.5, at lower pH treatments yields were greater but still smaller than at pH 5.6. Concentrations of P in the shoots increased as the pH of the treatment solutions decreased indicating that P uptake was not limiting in these plants. Plants not given P yielded only 1/3 the dry weight of the P+ treatments and showed little further effect of the acid rain treatments on shoot weight or P concentration except at pH 3.0 where yield was reduced by c.50% (Table 3).

Estimation of the nitrogen fixing capacity of the plants by measurements of acetylene reduction activity showed the clover - Rhizobium symbiosis to be highly sensitive to the pH of the treatment solutions and to the P nutrition of the plants. All acid deposition treatments reduced nodule development and nitrogenase activity. Effects were probably not due to the inhibition of the infection process since seeds were inoculated at planting and nodule initiation would have occurred before the spray treatments were begun at 3 weeks and before seed P reserves were depleted. Ethylene production was progressively reduced as the pH of the treatments became more acidic. However, plants given P still nodulated at pH 3.0 but activity was less than 5% of that at pH 5.6. Rates were much lower in P- plants and nodulation was absent or sporadic below pH 5.6 (Table 3).

The effects of a 1.6 cm rain per 10 min treatment (high dose) regime on plants grown in the more acidic Chiquito soil and inoculated with both Rhizobium and VAM (G. fasciculatus) were tested in a second experiment where ¹⁴C uptake and allocation were also determined. Plants were grown

for 10 weeks and received a total dose of 1160 ml/pot (equivalent to 7.2 cm rainfall). The total dose was less in this experiment than in the previous test at the high dose regime because lower greenhouse temperatures and lower plant growth in the autumn reduced the rate of water loss from the pots and the frequency at which the treatments could be applied.

Table 4. Dry weights of *T. repens* grown in Chiquito soil and treated with simulated acid rain.

pH	Dry weight (g)			
	Shoots	Roots	Nodules	Total
5.6	3.83 ^a	1.86 ^a	0.08	5.77 ^a
4.5	2.98 ^{ab}	1.61 ^a	0.01	4.59 ^{ab}
4.0	2.16 ^{bc}	1.22 ^a	0.00	3.38 ^{bc}
3.0	1.66 ^c	0.98 ^a	0.00	2.64 ^c
± SEM	0.21	0.19	-	0.41
P(pH)	0.005	0.074		0.009

values are means of 4 replicates

Shoot and total dry weights declined as the acidity of the treatment solutions was increased, total dry weight of the pH 3.0 treated plants was reduced to c. 45% of the controls (Table 4). Tissue P concentrations in these mycorrhizal plants in Chiquito soil which contained 13.8 ppm plant-available P, were similar to those in plants grown in the Dehli soil given additional P and were unaffected by the treatments. Differences in total P uptake were due primarily to effects on plant yield since concentrations in leaf and root tissue were not significantly affected by the pH of the treatment solutions (Table 5). Nodule development in the more acidic Chiquito soil was severely curtailed at pH 4.5 and none were

found at lower pH (Table 4). The ability of plants adequately supplied with P to support some limited nodulation even at pH 3.0, found in the Dehli soil, was not expressed in the Chiquito soil.

Leaf concentrations of Mn and Fe increased with the acidity of the treatment (Table 6), but differences were not statistically significant. Differences in Mn and Fe concentrations in roots, though significant, showed no clear trend with decreasing pH.

Table 5. Phosphorus uptake by *T. repens* grown in Chiquito soil and treated with simulated acid rain.

pH	P(ppm)	
	Leaves	Roots
5.6	2739	2099
4.5	2209	2684
4.0	2536	1817
3.0	2617	1777
±SEM	169	352
P(pH)	0.203	0.283

values are means of 4 replicates

Table 6. Concentrations of Mn and Fe in *T. repens* grown in Chiquito soil.

pH	Leaves		Roots	
	Mn	Fe	Mn	Fe
5.6	589	94	290 ^a	6860 ^{ab}
4.5	548	112	450 ^b	4851 ^a
4.0	630	161	285 ^a	7701 ^b
3.0	739	223	302 ^a	4201 ^a
±SEM	169	54	43	842
P(pH)	0.63	0.44	0.013	0.037

values are means of 4 replicates

Carbon uptake allocation and respiration

At ten weeks, plants from the pH 5.6, 4.0 and 3.0 treatments were labelled with $^{14}\text{CO}_2$ for 16h. Those receiving the pH 4.5 treatment were not labelled but were harvested along with the other plants. The incorporation, allocation and respiration of ^{14}C by *T. repens* was only slightly affected by the pH of the treatment solutions. Specific rates of net fixation, respiration and pool sizes were almost identical in the three treatments (table 7). Differences in net ^{14}C incorporation were primarily due to differences in plant size.

Table 7. Carbon throughput rates and C- pool size in *T. repens*.

pH	Net fixation (mg/g /h)	B/G respiration (mg/g /h)	C-pool (mg/g/)
5.6	1.192	0.535	32.8
4.0	1.110	0.414	37.1
3.0	1.275	0.482	28.1
±SEM	0.113	0.171	3.43
P(pH)	0.61	0.51	0.26

Rates are expressed per g total dry weight and are means of 3 replicates.

Decreasing pH resulted in an increase in the ^{14}C released to the soil by a factor of 2 between pH 5.6 and 3.0. The presence of root nodules in the pH 5.6 treatment may explain the slight increase in below ground allocation in these plants (Table 8).

Table 8. Distribution of ^{14}C in *T. repens*.

pH	Percent total ^{14}C fixed					
	Shoot	Root	Nodule	B/G resp.	Soil	B/G total
5.6	44.98	11.57	1.84	38.93 ^a	2.57 ^a	54.91
4.0	48.36	11.43	0.00	35.73 ^b	4.68 ^b	51.84
3.0	47.82	11.32	0.00	35.73 ^b	5.13 ^b	52.18
± SEM	1.55	0.68	-	0.69	0.58	1.49
P(pH)	0.32	0.97		0.01	0.05	0.35

Isotopic composition of CO_2 evolved below ground

The ratio of ^{14}C to ^{12}C (specific activity) of CO_2 evolved by respiration below ground is an indication of the turnover rate of the C in the shoot - root-soil system under the conditions of the different treatments. Curves representing the specific activity of the CO_2 evolved in root and soil respiration relative to the specific activity of the input CO_2 are shown in (Fig. 6). The CO_2 evolved by plants treated at pH 5.6 and 4.0 had similar curves and maximum input/output ratios of 0.5 and 0.56, whilst the maximum ratio for the pH 3.0-treated plants was higher at 0.7. High turnover rates may be due to high rates of throughput (i.e. fixation, growth and respiration) or to a small pool of metabolically active, non-structural C. Since rates of fixation and respiration, carbon distributions and calculated below ground pool sizes were almost identical in the three treatments, these alone do not provide an explanation of the data. It is possible that changes in the size of an above ground pool could account for the differential dilution rates of the below ground C observed in this experiment.

Fig. 6 Specific activity of CO₂ evolved in below ground respiration by I. repens treated with acid rain.

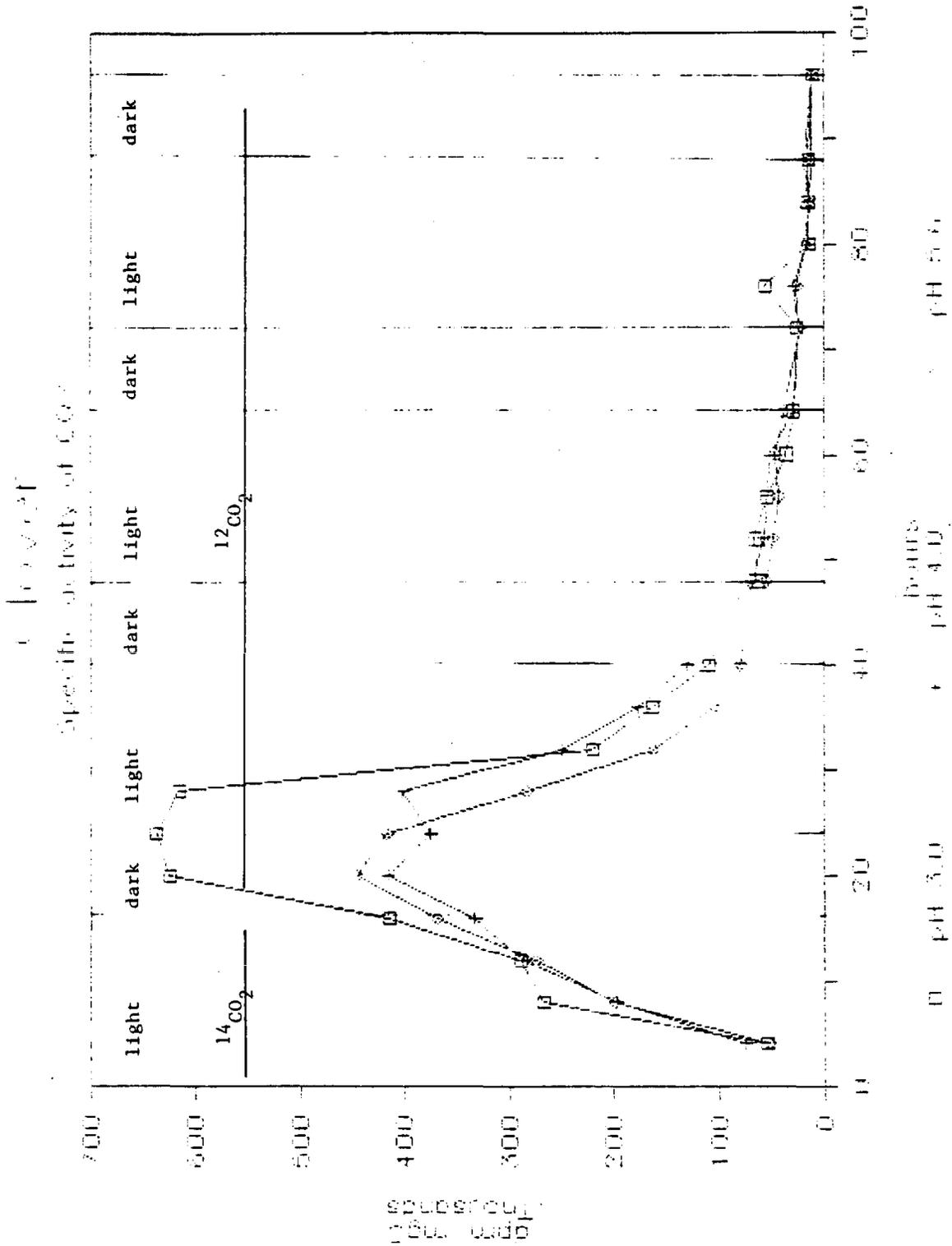

Effects of mycorrhizal infection on growth and nitrogenase activity.

The interaction between acid rain treatments, rhizobial inoculation and infection of T. repens with VAM was examined in Chiquito soil. Plants were grown for 10 weeks and sprayed at the low dose, the total application of treatment solutions was 1102 ml (equivalent to 7.2 cm rainfall). The pH 5.6 and 3.0 treatments alone were tested.

Mycorrhizal infection increased plant yield in both acid treatments by c. 100%. The acidity of the treatment solution did not affect the percentage infection by VAM or plant growth in either the mycorrhizal or non-mycorrhizal treatments. Under the conditions of this low dosage of acid rain nitrogenase activity was reduced but not eliminated at pH 3.0 in both VAM+ and VAM- plants (Table 9). The comparison of these effects with those on plant dry weight and nodule development in the previous experiment (Table 4) are interesting. Very similar total amounts of treatment solutions were applied in the two experiments but in the first a smaller number of longer duration spray treatments were delivered than in this experiment where frequent short spray treatments were applied.

Shoot P and Mn concentrations were increased in mycorrhizal plants and Fe concentrations reduced. The acidity of the treatment solutions again had no effect on the concentrations of these elements in plant tissues (Table 10).

Table 9. Growth and nitrogenase activity in *T. repens* grown in Chiquito soil with or without mycorrhizal inoculation and treated with acid rain at the low dose regime.

pH	Vam	Total dw (g)	C ₂ H ₄ (μl/plant/h)	VAM (%infection)
5.6	+	1.80	5.71	62.3
3.0	+	1.96	0.78	68.5
5.6	-	1.04	3.20	4.4
3.0	-	1.00	1.10	6.9
±SEM		0.19	1.53	5.5
P(pH)		0.74	0.03	0.85
P(Vam)		< 0.001	0.48	< 0.001
P(pH x Vam)		0.58	0.36	0.69

values are means of 10 replicates

Table 10. Shoot P, Mn and Fe concentrations in *T. repens* grown in Chiquito soil with or without mycorrhizal inoculation and treated with acid rain at the low dose regime.

pH	Vam	Concentration (ppm)		
		P	Mn	Fe
5.6	+	2555	704	515
3.0	+	2575	794	586
5.6	-	2123	377	1213
3.0	-	2045	427	1087
±SEM		161	54	281
P(pH)		0.86	0.18	0.92
P(Vam)		0.005	0.001	0.04
P(pH x Vam)		0.77	0.78	0.73

values are means of 10 replicates

Growth and carbon flow in *Lupinus benthamii*

When *L. benthamii* was grown for 10 weeks in Dehli Sandy Loam and treated with simulated acid rain at a high dose regime (total dose equivalent to 16.8 cm rainfall applied as 10 x 10 min spray treatments) the yield was affected primarily in plants not given additional P. In plants supplied with P, the pH 4.5 and 4.0 treatments gave the smallest yields and pH 3.0 the largest but overall differences were small. Effects in P-treated plants differed in that the total dry weight of the pH 5.6 treatment was much greater than any of the other acidic treatments (Table 11). Shoot P concentrations were markedly reduced by increasing acidity in plants not given additional P (Table 11). This suggests an interaction between the P nutrition of the plants and their ability to resist the inhibitory effects of the acidic treatments.

Table 11. Dry weights and shoot P concentrations in *L. benthamii* grown in Dehli Sandy Loam and treated with simulated acid rain at a high dose regime.

pH	Total dw (g)		Shoot P (ppm)	
	P+	P-	P+	P-
5.6	3.30 ^a	1.80 ^c	3164 ^{ab}	3564 ^{ab}
4.5	2.24 ^{bc}	0.36 ^d	2622 ^a	1055 ^c
4.0	2.70 ^{ab}	0.42 ^d	3910 ^b	1277 ^c
3.0	3.71 ^a	0.62 ^d	3685 ^{ab}	682 ^d
±SEM	0.16		187	
P(pH)	<0.001		<0.001	
P(P)	<0.001		<0.001	
P(pH x P)	<0.001		<0.001	

values are means of 4 replicates

The production of ethylene from acetylene in assays of nitrogenase activity in the nodulated root systems was greatest in plants treated at pH 5.6. In P+ treated plants the rates of ethylene production were much higher than in plants not given P. Treatment at pH 4.5 or lower reduced ethylene production at least threefold and in the P- pH 3.0 treatment none was detected (Table 12).

Table 12. Nitrogenase activity in *L. benthamii* grown in Dehli Sandy Loam and treated with simulated acid rain at a high dose regime.

Treatment pH	Ethylene production ($\mu\text{l/plant/h}$)			
	P+		P-	
	C ₂ H ₄	$\pm\text{SE}$	C ₂ H ₄	$\pm\text{SE}$
5.6	101.0	23.1	20.3	3.2
4.5	12.6	5.6	2.8	1.6
4.0	31.4	8.2	2.3	1.4
3.0	33.0	6.1	0	-

P(pH) = 0.002, P(P) < 0.001, P(pH x P) = 0.081
values are means of 4 replicates.

Mycorrhizal inoculation

The inoculation of both *L. benthamii*, *L. densiflorus* and also of *L. bicolor* with strains of *G. fasciculatus* and *G. mosseae* failed to produce normal VAM infections in both test soils. Roots were occasionally penetrated by the fungal hyphae but intraradicle growth was immediately restricted and none of the fungal structures typical of mycorrhizal infection in other species were formed. Little host specificity is shown by VAM, and although possible, it is unlikely that these lupins were

resistant only to the particular mycorrhizal strains tested. Samples of lupin roots collected from the field at soil collection sites also showed no normal VAM infections

The effects of the acid deposition treatments on L. benthamii grown in Chiquito soil were also tested. Plants were inoculated with Rhizobium, all received supplementary P additions. Treatment solutions were applied at the high dose regime giving a total dose of 1450 ml/pot (equivalent to 9.5 cm rainfall). At six weeks, plants of the pH 4.0 and 4.5 treatments were harvested directly. Plants of the pH 5.6 and 3.0 treatments were labelled with ¹⁴C before harvest. Two plants of the pH 5.6 treatment developed a black fungal smut disease and were discarded leaving only 2 replicates; other treatments were replicated 4 times.

Increasing acidity in the treatment solutions resulted in a progressive reduction in the dry weights of all plant parts including root nodules. Relatively large differences in shoot and total dry weights between plants treated at pH 5.6 and pH 4.5 were not statistically significant, probably due to the loss of 2 of the pH 5.6 treated plants. The mean root dry weight and root/shoot ratio for plants treated at pH 5.6 were much higher than those of the other treatments but were similar in the 2 replicates (Table 13). Phosphorus uptake was similarly reduced with increasing acidity (Table 14). Effects on tissue concentrations were greatest in leaves decreasing from 3370 ppm at pH 5.6 to 876 ppm at pH 3.0. Concentrations in stems and roots were little affected by treatment and differences in total P uptake were due primarily to dry weight differences.

Table 13. Dry weights of *L. benthamii* grown for 6 weeks in Chiquito soil.

pH	Shoot	Dry weight (g)			Total
		Root	Nodule		
5.6*	1.15 ^a	3.25 ^a	0.028 ^a	4.42 ^a	
4.5	0.83 ^a	0.57 ^b	0.009 ^b	1.41 ^a	
4.0	0.78 ^a	0.34 ^b	0.003 ^b	1.12 ^a	
3.0	0.34 ^b	0.31 ^b	0.001 ^b	0.65 ^a	
±SEM	0.14	0.30	0.006	0.65	
P(pH)	0.022	0.001	0.002	0.162	

* two replicates were lost, other values are means of 4 replicates

Table 14. Phosphorus uptake by *L. benthamii* grown for 6 weeks in Chiquito soil.

pH	Leaf	P (mg/plant)			Total
		Stem	Root		
5.6*	2.05	0.58	2.43 ^a	5.05 ^a	
4.5	1.74	0.78	1.01 ^b	3.53 ^{ab}	
4.0	0.81	0.56	0.58 ^b	1.95 ^{bc}	
3.0	0.13	0.19	0.32 ^b	0.63 ^c	
±SEM	0.40	0.14	0.24	0.73	
P(pH)	0.106	0.131	0.002	0.029	

* two replicates were lost, other values are means of 4 replicates

Concentrations of Mn in both leaves and roots of *L. benthamii* were similar and in the range where toxicity might be expected. Despite considerable variability there was an increasing trend, especially in the roots, with the acidity of the applied rainfall (Table 15).

Table 15. Manganese concentrations in *L. benthamii* grown for 6 weeks in Chiquito soil.

pH	Mn(ppm)	
	Leaves	Roots
5.6*	794	634 ^a
4.5	1028	718 ^{ab}
4.0	909	1109 ^{ab}
3.0	1274	1565 ^b
±SEM	122	167
P(pH)	0.055	0.021

* two replicates were lost, other values are means of 4 replicates

Carbon fixation, allocation and respiration in *L. benthamii*

The net gains of C by *L. benthamii* during the 16h labelling period was in agreement with the total dry weights of the plants, in that the mean rate of C accumulation at pH 5.6 was approximately 5 times greater than at pH 3.0 (Table 16). Replicate pots differed in the ratio of fixation of ¹⁴CO₂ to evolution of total CO₂ in below ground respiration, this was probably due to the relationship between root and soil respiration, very small plants would contribute a smaller proportion of the total CO₂ output of the soil-root system. In larger plants the contribution of soil respiration to the total below ground system would be small compared to that evolved from the root system.

Table 16. Carbon balance in *L. benthamii* grown in Chiquito soil and labelled for 16h with $^{14}\text{C}\text{O}_2$.

pH	Net Fixation mgC/plant/h	B/G respiration mgC/plant/h	Total dw(g)	Net gain mgC/plant/h
5.6*	2.92	1.37	4.42	1.24
3.0	0.49	0.26	0.65	0.23
±SEM	0.24	0.08	0.78	0.28
P(pH)	0.003	0.001	0.014	0.071

* two replicates were lost, other values are means of 4 replicates

The distribution of ^{14}C between plant parts and beneath ground respiration in *L. benthamii* was broadly similar to that observed in *L. repens* except that a slightly higher proportion of the ^{14}C was allocated below ground. Plants treated at pH 3.0 retained 8% more of the fixed ^{14}C in the shoots than those sprayed with pH 5.6 rain, but differences were not statistically significant (Table 17).

Table 17. Distributions of ^{14}C in *L. benthamii* grown for 6 weeks in Chiquito soil.

pH	Percent of total ^{14}C fixed			B/G res.	Soil	B/G total
	Shoot	Root	Nodule			
5.6	36.6	9.7	0.8	41.9	10.3	63.4
3.0	44.2	7.0	0.1	44.0	4.6	55.8
±SEM	3.9	0.9	0.23	3.3	1.7	3.9
P(pH)	0.33	0.16	0.17	0.74	0.11	0.33

The rates of $^{14}\text{CO}_2$ incorporation per g leaf were reduced in the pH 3.0 treatment by 25% in comparison to controls (Table 18), but this difference was not statistically significant. Carbon pool sizes were unaffected by the acid treatments but were slightly smaller than those found for *L. repens*.

Table 18. Specific $^{14}\text{CO}_2$ fixation rates and pool sizes in *L. benthamii*.

pH	Net fixation (mg ^{14}C /g/h)	C-pool (mgC/gdw)
5.6	4.86	20.21
3.0	3.73	22.62
±SEM	0.45	3.31
P(pH)	0.22	0.70

Net fixation is expressed per g dry weight of leaf
Pool size calculated after 16h labelling with $^{14}\text{CO}_2$.

Growth of *L. densiflorus*

Preliminary growth studies showed that this lupine grew poorly in the Chiquito soil, this was attributed to its low pH. *L. densiflorus* has been reported to favour soils of neutral pH (O'Leary, 1982) and seed was obtained from stocks used for revegetation of roadcut sites in the central valley. Experiments with this species are therefore confined to the Dehli Sandy Loam which originated east of Los Angeles.

When treated with simulated rainfall at the high dose regime (total rainfall = 16.8 cm applied as 10 x 10 min spray treatments) the pH of the rain affected the growth of the plants both with and without additional P.

Table 19. Dry weights of *L. densiflorus* grown for 11 weeks in Dehli Sandy Loam and treated with simulated acid rain at a high dose regime.

pH	P	Dry weight (g)		Total	R/S ratio
		Shoot	Root		
5.6	+	4.09	1.56	5.65	0.38 ^a
3.0	+	2.96	1.50	4.46	0.51 ^{ab}
5.6	-	2.37	1.16	3.54	0.49 ^{ab}
3.0	-	1.74	1.05	2.79	0.61 ^b
±SEM		0.35	0.17	0.51	0.04
P(pH)		0.07	0.65	0.13	0.03
P(P)		0.01	0.07	0.02	0.04
P(pH x P)		0.53	0.89	0.69	0.90

The addition of P increased total dry weight and decreased root to shoot ratios in both pH treatments by 20 - 25%. Treatment with pH 3.0 acid rain reduced growth of the shoot by 25% in both P+ and P- treatments, but this effect was not statistically significant. Effects on

root growth and total dry weight were small (Table 19). The synergistic effects of pH and P deficiency on plant growth shown by L. benthamii were not detected in L. densiflorus.

Table 20. Phosphorus uptake by L. densiflorus grown for 11 weeks in Dehli Sandy Loam and treated with simulated acid rain.

Treatment		P (ppm)	
pH	P	shoots	Roots
5.6	+	4120 ^a	5109 ^a
3.0	+	1771 ^b	3087 ^b
5.6	-	4029 ^a	3129 ^b
3.0	-	2223 ^b	2059 ^c
±SEM		209	457
P(pH)		0.001	0.018
P(P)		0.437	0.020
P(pH x P)		0.264	0.598

P concentrations in leaves of acid treated plants were 40 - 55% of that in plants exposed to pH 5.6 rain. Effects of treatment pH on P concentrations in roots were smaller (35 - 40 % reduction at pH 3.0). The addition of P increased P concentrations in roots but not in leaves (Table 20).

Carbon fixation, allocation and respiration

The net gain of carbon by L. densiflorus during the labelling period did not reflect differences in total or leaf dry weight in plants of different treatments. This was probably due to developmental variations between treatments. From the carbon balance data (Table 21), plants given

supplemental P and treated with pH 3.0 rain, showed the highest rate of C fixation per plant and the highest net rate of growth in terms of C accumulation. These comparative rates cannot have been sustained at earlier stages of growth since these plants showed 30% less dry matter accumulation than plants treated with pH 5.6 rain. This indicates the sensitivity of the lupines to acidity in early growth and the ability to overcome this sensitivity with age. The yield effects shown could therefore have been quite different if the plants had been taken to maturity.

Table 21. Carbon balance in *L. densiflorus* grown for 11 weeks in Dehli Sandy Loam.

pH	P	Fixation	(mgC/plant/h)	
			B/G respiration	Net gain
5.6	+	5.03	2.68	2.36
3.0	+	6.06	2.24	3.82
5.6	-	4.69	1.80	2.89
3.0	-	3.40	1.08	2.32
±SEM		0.63	0.26	0.46
P(pH)		0.85	0.09	0.39
P(P)		0.08	0.02	0.35
P(pH x P)		0.14	0.63	0.09

The distribution of ^{14}C between above and below ground plant parts and below ground respiration was similar in all treatments except where pH 3.0 rain was applied to plants without additional P. In these plants more ^{14}C was retained in leaves and less was found in root biomass than in those of the other treatments (Table 22). This differential distribution

of ^{14}C reflects the previously noted delayed development of leaf and shoot material in these plants, which would result in the eventual reduction of the high root/shoot ratio found in this treatment.

The proportion of ^{14}C lost to the soil either as exudates or as sloughed root material and root hairs was large compared to values found for other legumes and also showed high variability. Although great care was taken to remove all visible root material from the soil it is possible that some of the ^{14}C found in the soil could have been present as small root fragments which were not recovered on harvesting the plants. However, it is extremely unlikely that 50% of the root biomass could have been lost in this way. Exudation may provide the explanation for this large loss of C, the presence of a very highly developed root hair system in lupins would present a large surface susceptible to 'leakage'.

Table 22. Distributions of ^{14}C in *L. densiflorus*

Treatment		Percent total ^{14}C fixed				
pH	P	Shoot	Root	BG/resp.	Soil	B/G Total
5.6	+	37.1 ^a	21.7	33.4 ^a	8.3	63.4 ^a
3.0	+	35.7 ^a	23.2	29.6 ^b	11.5	64.3 ^a
5.6	-	34.4 ^a	19.6	31.5 ^{ba}	14.6	65.6 ^a
3.0	-	47.0 ^b	15.2	29.7 ^b	8.2	53.0 ^b
±SEM		1.3	3.2	0.8	2.8	1.5
P(pH)		0.013	0.679	0.026	0.602	0.018
P(P)		0.032	0.196	0.320	0.636	0.041
P(pH x P)		0.006	0.424	0.320	0.165	0.012

Fig. 7. Specific activity of CO_2 released below ground by *L. densiflorus* treated with acid rain.

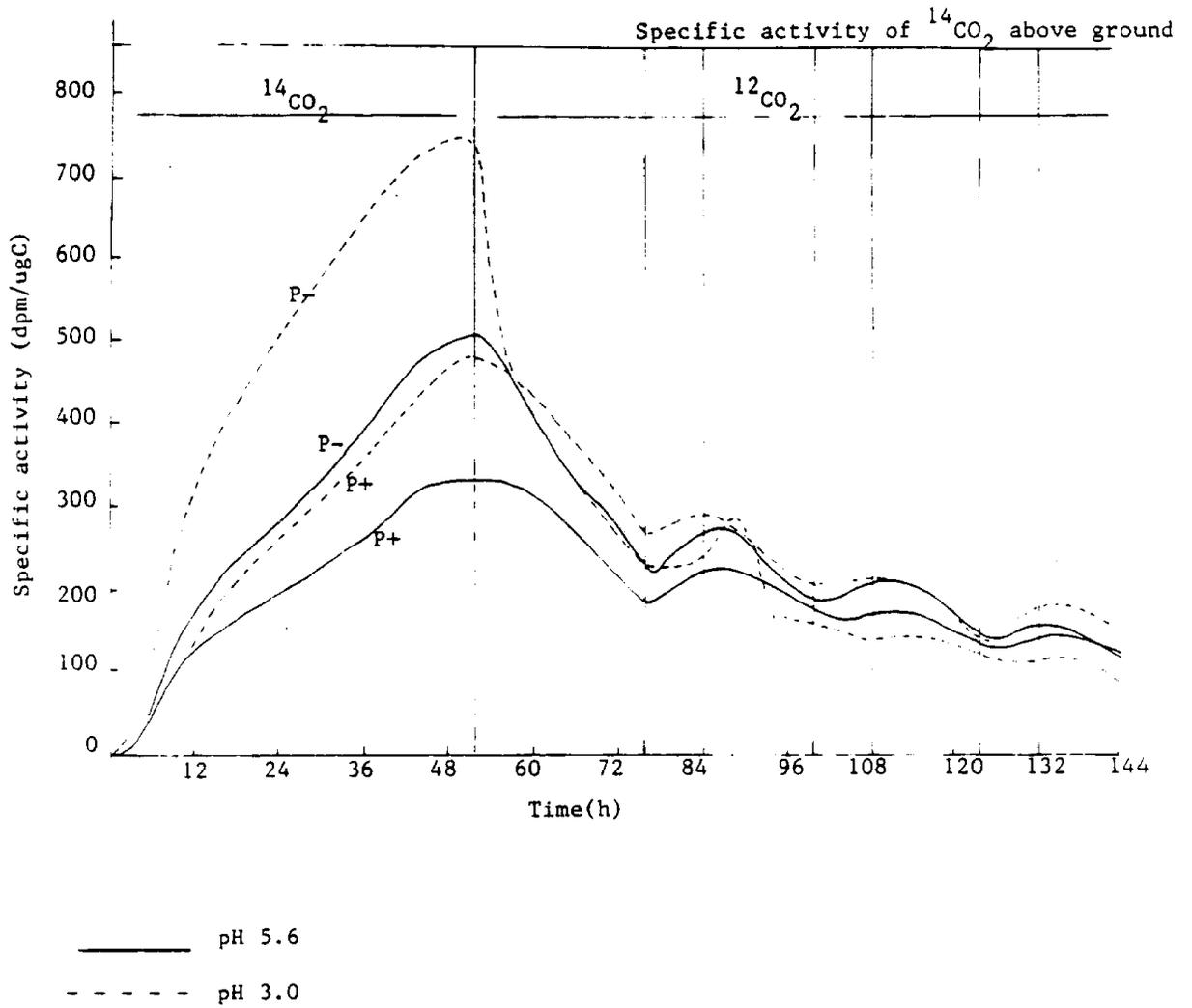

The below ground allocation of 53 - 63% of the total C uptake was almost identical to that in L. benthamii though a smaller proportion was evolved as CO₂, and indicates the importance of the energy requirements of the root system in the physiology of the whole plant.

The ratio of ¹⁴C to ¹²C in CO₂ evolved by respiration below ground showed large differences between treatments. Curves representing the specific activity of CO₂ evolved in root and soil respiration relative to the specific activity of the CO₂ supplied to the plant shoots during labelling are shown in Fig. 7. The CO₂ evolved by plants given supplemental P and pH 5.6 rain was of the lowest specific activity and the CO₂ of the plants treated with pH 3.0 rain without added P, the highest. In plants of this latter treatment, the ratio of input to output specific activity reached a maximum of 0.88, indicating that almost all of the metabolically active carbon in these plants was replaced by ¹⁴C during the 52h labelling period. In contrast the turnover rate of C in P⁺, pH 5.6 treated plants was much lower and the maximum specific activity ratio was 0.39.

Fixation and respiration rates in plants treated with pH 3.0 rain, not given additional P, were low compared to those of other treatments but differences were not statistically significant. Calculation of pool sizes show a depletion of the carbon pool in plants of this treatment (Table 23). This data may indicate that plants of the P⁻, pH 3.0 treatment were limited by photosynthetic capacity due both to the relatively small amount of leaf and its inherently low specific rate of CO₂ fixation.

Table 23. Carbon throughput rates and pool sizes in *L. densiflorus* grown in Dehli Sandy Loam and treated with simulated acid rain.

pH	P	Fixation (mg ¹⁴ C/g/h)	Respiration	C-pool (mgC/g dw)
5.6	+	4.86	1.34 ^a	106.5 ^a
3.0	+	5.95	1.06 ^b	108.6 ^a
5.6	-	5.65	1.09 ^b	99.6 ^a
3.0	-	3.70	0.68 ^c	66.0 ^b
±SEM		0.65	0.05	4.21
P(pH)		0.55	0.003	0.020
P(P)		0.33	0.005	0.004
P(pH x P)		0.08	0.304	0.013

Fixation and respiration are expressed per unit of leaf and root respectively and C-pool per g total dry weight.

In a second experiment, a low dose regime of spray treatments was employed and a total of 930 ml/pot (equivalent to 6.0 cm rainfall) of the treatment solutions was applied during a ten week growing period. In contrast to the earlier experiment the growth of *L. densiflorus* was enhanced by acidity in the simulated rain. Where plants were given additional P, maximum yield was obtained when pH 4.5 solution was applied, but all acidic treatments resulted in greater shoot dry weight and total P content than at pH 5.6. Without additional P, effects on shoot dry weight were smaller but the highest yield was found in plants treated with pH 3.0 rain, total P uptake was greatest at pH 4.0 (Table 24).

Table 24. Shoot dry weight and P uptake by *L. densiflorus* grown for 10 weeks in Dehli Sandy Loam and treated with simulated acid rain in a low dose regime.

pH	Shoot dw (g)		Shoot P (ppm)	
	P+	P-	P+	P-
5.6	1.43	1.08	3520	2282
4.5	2.42	1.13	4052	2571
4.0	1.92	1.35	3295	2713
3.0	1.64	1.37	3268	2465
±SEM	0.17		195	
P(pH)	0.024		0.124	
P(P)	<0.001		<0.001	
P(pH x P)	0.022		0.072	

Values are means of 6 replicates

Table 25. Concentrations of manganese and iron in shoots of *L. densiflorus* treated with simulated acid rain in a low dose regime.

Treatment	Concentration (ppm)				
	pH	Mn		Fe	
P+		P-	P+	P-	
5.6	111 ^a	248 ^c	549	277	
4.5	127 ^a	214 ^{bc}	730	644	
4.0	171 ^b	238 ^c	765	375	
3.0	186 ^b	241 ^c	670	483	
±SEM	13		159		
P(pH)	0.006		0.396		
P(P)	<0.001		0.052		
P(pH x P)	0.033		0.795		

values at individual pH treatments are means of 6 replicates.

Manganese concentrations in plants given P fertilizer increased as the pH of the treatment solution became more acidic. Concentrations of Mn in plants without added P were greater than in P supplemented plants but no effect of pH was detected. Iron concentrations were very variable and showed no clear trend with pH, but were slightly higher in the P+ than in the P- plants (Table 25).

Discussion

Simulated acid rain adversely affected growth and nitrogen-fixing capacity of the legume spp. in both test soils, when applied in a high dose regime equivalent to rainfall events of 1.6 cm. However, these effects were absent or positive when treatment solutions were applied in a low dose regime which wetted plant foliage but did not thoroughly wet the soil. Positive plant yield responses have been attributed to the addition of N and S in acid rain treatments (McColl, 1981;1984), but this is not a likely explanation of the results reported here, since all treatments were given nutrient solutions which contained relatively high concentrations of N and S.

The absence of effects of acid rain treatments on rates of net photosynthesis and C-allocation, suggests that the inhibitory effects on plant growth may have been due to decreased nutrient uptake. Porter and Sheridan (1981) found no effect of HNO₃ on rates of photosynthesis in alfalfa leaves (Medicago sativa) at pH 2.0; H₂SO₄ reduced rates by 55% at pH 2.0 but had no effect at higher pH. Indicating that photosynthesis itself may be relatively insensitive to the pH of treatment solutions.

Measurements of carbon balance in T. repens and L. densiflorus at 10-11 weeks after planting showed similar specific growth rates at all pH treatments. However, plant yield was reduced by c. 50% at pH 3.0; thus the acid-treated plants must have grown more slowly than the pH 5.6 controls at earlier stages of development. Carbon fixation rates in 6 week-old L. benthamii plants treated at pH 3.0 were reduced by 25% compared to pH 5.6 controls. Specific growth rates were also reduced but the effects were

insufficient to account for the 85% reduction in plant yield at pH 3.0. These findings and the observed sensitivity of seedlings to the acid spray treatments suggest that young plants show less resistance to acid rain treatments than established plants. However, seedlings were not subjected to acid rain treatments except in preliminary tests and these observations should be treated as provisional.

The addition of phosphorus to both test soils greatly increased plant growth and reduced the adverse effects of acid rain treatments on growth and to a lesser extent on nodulation. This effect was seen most clearly in L. benthamii grown in the P-deficient Dehli sandy loam, where the addition of P resulted in a 6-fold increase in plant dry weight at pH 3.0 compared to a 2-fold increase when the treatment pH was 5.6.

The development of root nodules was extremely sensitive to the pH of the treatment solutions. At the high dose regime (1.6 cm rainfall/event), and without additional P, nodulation in T. repens was infrequent below pH 4.5, whilst in L. benthamii some nodules were formed at pH 4.0 but none at pH 3.0. The addition of P to the soils extended the pH range over which nodules developed to include pH 3.0, but nitrogenase activity was severely restricted below pH 5.6. These results suggest that sensitivity of legumes to acid rain is most likely in P-deficient soils and that this might be ameliorated by P fertilization in suitable sites. Sensitivity of nodulation in legumes to inhibition by acid rain (Shriner and Johnson, 1981; Evans et al., 1980) has been reported previously. However, the work of McColl et al., 1984, showed only slight effects of acid rain treatments on nodulation and N fixation in clover in long term experiments. Reasons for this difference are unknown, the soils used by McColl et al. were of similar parent

material to the Chiquito soil used in this study though from lower elevations, and acid rain treatments were broadly comparable. It is possible that in long-term experiments an early inhibition of nodule development may be overcome. The process of infection by Rhizobium is considered to be the most acid-sensitive step in the nodulation process (Evans et al., 1980). However, in this study, acid rain treatments were delayed for 3-4 weeks after planting and inoculation, allowing infection to occur before treatments were begun. Therefore the development of nodules after infection is also shown to be an acid rain-sensitive process.

In N-limited environments, legumes gain competitive advantage from their ability to support N fixation by Rhizobium. This plays an important role in the N economy of ecosystems such as the rangelands of California, which depend on legumes for the majority of their N supply. From the results of this study, nodule development appears to be more sensitive to inhibition by acid rain treatments than the growth of host plants. If N fixation were seriously affected by acid rain, clovers and lupins would probably be outcompeted by other species leading to a reduction of N input and the eventual impoverishment of the ecosystem.

Infection of T. repens by the mycorrhizal fungus G. fasciculatus showed no evidence of sensitivity to acid rain treatments in these experiments. The possible inhibition of mycorrhizal spore germination by acidity and metal ions (Mosse et al., 1981) may have been avoided in this study since germination and infection could have occurred before acid treatments were applied. Mycorrhizal infection in T. repens in the Chiquito soil increased plant yield and tissue P concentrations but did not ameliorate the inhibitory effect of pH 3.0 acid rain on nitrogenase activity

in root nodules. Stimulation of N fixation by mycorrhizal infection has been reported by a number of investigators (Mosse, 1977; Smith and Daft, 1977; Munns and Mosse, 1980). Robson et al (1981) and Crush (1982) show that the enhancement of nodulation and nitrogen fixation in mycorrhizal clover can be simulated by increased phosphorus and that stimulation occurs only in soils of low P availability. The availability of P in the Chiquito soil was moderate and tissue P concentrations in non-mycorrhizal plants may not have limited nodule development. If so, the observed enhancement of plant growth by the mycorrhiza may have been due to some factor other than the enhancement of P uptake.

No normal VAM infections were found in the lupin spp. in the glasshouse tests or in samples collected in the field. Morely and Mosse (1976) suggested that the resistance of lupins to VAM infection may be due to the production of a toxin which can also inhibit the infection of nearby plants of susceptible species. Trinick (1977) and Gardner and Parberry (1982) have investigated the ability of non-mycorrhizal lupins to grow well in P-deficient soils in Australia and suggest that the roots of some lupin spp. may be specially adapted for the uptake of P by the formation of 'proteiod roots'. These are dense clusters of secondary roots which in addition to presenting a large surface area for absorption, may differ from normal roots in their uptake characteristics. We did not observe their formation in this study, however, root hair development in the lupin spp. was much more extensive than in clover and other legumes.

References

- Ambler, J. R. and Young, J. L. 1977.
Techniques for determining root length infected by vesicular arbuscular mycorrhizae.
Soil Science Society of America Journal, **41**,
- Crush, J.R. 1982.
Effects of endomycorrhizas and phosphorus fertilizer on nodulation and acetylene reduction activity of white clover seedlings.
New Zealand Journal of Experimental Agriculture, **10**, 297-299.
- Evans, L.S., Lewin, K.F. and Vella, F.A. 1980.
Effect of nutrient medium pH on symbiotic nitrogen fixation by Rhizobium leguminosarum and Pisum sativum.
Plant and Soil, **24**, 153-166.
- Firestone, M.K., McColl, J.G., Killham, K.S. and Brooks, P.D. 1984.
Direct and indirect effects of acidic deposition on vegetation.
In; Acid Precipitation Series Volume 5. J.I. Teasley ed.
Butterworth Publishers.
- Fuchs, A. and DeVries, F.W. 1972.
A comparison of methods for the preparation of ¹⁴C-labelled plant tissues for scintillation counting.
International Journal of Applied Radiation and Isotopes, **23**,
361-369.
- Gardner, W.K. and Parberry, D.G. 1982.
The aquisition of phosphorus by Lupinus albus L.

Plant and Soil, **68**, 19-29.

Kliewer, W.M. 1961.

The effects and interactions of various combinations of molybdenum, aluminum, manganese, phosphorus, nitrogen, calcium, hydrogen ion concentration, lime and rhizobium strains on growth, composition and nodulation of several legumes.

PhD Thesis, Cornell University, 212 pp.

Kucey, R.M.N., 1980

Vesicular-arbuscular mycorrhizal fungi in Saskatchewan soils and their effect on the growth of Faba beans.

PhD Thesis, University of Saskatchewan.

McColl, J.G. 1981.

Effects of acid rain on plants and soils in California.

Final Report to California Air Resources Board,

Contract #A8-136-3.

McColl, J. G. and Firestone, M. K. 1984.

Cumulative effects of acid rain on plant productivity and soil nutrient supply under California conditions.

Final Report to California Air Resources Board.

McGlaughlin, S.B., McConathy, R.K. and Sigal, L.L. 1982.

Effects of gaseous pollutants and acid rain on growth processes of natural terrestrial vegetation.

USEPA Acidic deposition program, Raleigh, North Carolina.

February 9-12, 1982.

Morely, C.D. and Mosse, B. 1976.

Abnormal vesicular-arbuscular mycorrhizal infections in white

clover induced by lupin.

Transactions of the British Mycological Society, **67**, 20.

Mosse, B. 1977.

Plant growth responses to vesicular-arbuscular mycorrhizas.

Response of Stylosanthes and maize to inoculation in unsterile soil.

New Phytologist, **78**, 277-288.

Mosse, B., Stribley, D.P. and LeTacon, F. 1981.

Ecology of mycorrhizae and mycorrhizal fungi.

In: M. Alexander (ed.), Advances in Microbiology, Vol. 5. Plenum Press, New York.

Munns, D.N. and Mosse, B. 1980.

Mineral nutrition of legume crops.

In: Summerfield, R.J. and Bunting, A.H. (eds.), Advances in Legume Science. Ministry of Agriculture Fisheries and Food, England. pp 115-125.

O'Leary, J. F. 1982.

Habitat preferences of Lupinus (Fabaceae) in the western transverse ranges of southern California.

Naturalist, **27**, 369-397.

Paul, E.A. and Kucey, R.M.N. 1981.

Carbon flow in plant microbial associations.

Science, **213**, 473-474.

Phillips, J.M. and Hayman, D.S. 1970.

Improved procedures for clearing roots and staining parasitic and VA mycorrhizal fungi for rapid assessment of infection.

- Transactions of the British Mycological Society, **55**, 158-161.
- Porter, J.R. and Sheridan, R.P. 1981.
Inhibition of nitrogen fixation in alfalfa by arsenate, heavy metals, flouride, and simulated acid rain.
Plant Physiology, **68**, 143-145.
- Robson, A.D., O'Hara, G.W. and Abbott, L.K. 1981.
Involvement of phosphorus in nitrogen fixation by subterranean clover (Trifolium subterraneum L.).
Australian Journal of Plant Physiology, **8**, 427-436.
- Shriner, D.S. and Johnson, J.W. 1981.
Effects of simulated acid rain on nodulation of leguminous plants by Rhizobium spp.
Environmental and Experimental Botany, **21**, 199-209.
- Smith, S.E. and Daft, M.J. 1977.
Interactions between growth, phosphate content and nitrogen fixation in mycorrhizal and non-mycorrhizal Medicago sativa.
Australian Journal of Plant Physiology, **4**, 403-413.
- Trinick, M.J. 1977
Vesicular arbuscular infection and soil phosphorus utilization in Lupinus spp.
New Phytologist, **78**, 297-304.

Key to symbols and AbbreviationsUnits of measurement

meq	milliequivalent
μ l	microliter
ml	milliliter
l	litre
cm	centimeter
m	meter
g	gram
kg	kilogram
μ Ci	microcurie

Chemical symbols

C	carbon	CO ₂	carbon dioxide
O	oxygen	H ₂ SO ₄	sulphuric acid
Na	sodium	HNO ₃	nitric acid
K	potassium	H ₃ PO ₄	phosphoric acid
Ca	calcium	C ₂ H ₄	ethylene
Fe	iron		
Mn	manganese		
N	nitrogen		
P	phosphorus		
Cl	chlorine		

CEC	cation exchange capacity
SA	specific activity
dpm	disintegrations per minute
pH	-log hydrogen ion concentration

Statistical abbreviations

SE	standard error of mean
SEM	standard error of means, calculated from residual mean square from analysis of variance.
P()	probability for null hypothesis

