

DIAGNOSTICS FOR EMISSION CONTROL  
SYSTEM MALFUNCTION ON THREE-WAY  
CATALYST-EQUIPPED VEHICLES

Final Report

A2-047-32

Prepared for:

CALIFORNIA AIR RESOURCES BOARD  
El Monte, California

Prepared by:

ENERGY AND ENVIRONMENTAL ANALYSIS, INC.  
1655 North Fort Myer Drive  
Arlington, Virginia 22209

November 1985



PHASE I



TABLE OF CONTENTS

	<u>Page</u>
1. INTRODUCTION .....	1-1
2. REVIEW OF MANUFACTURER RECOMMENDED DIAGNOSTIC PROCEDURES .....	2-1
2.1 Introduction .....	2-1
2.2 Secondary Air Systems .....	2-5
2.3 EGR Systems .....	2-9
2.4 Fuel Systems .....	2-13
2.5 Catalyst System .....	2-23
3. SURVEY OF FIELD MECHANICS .....	3-1
3.1 Introduction .....	3-1
3.2 Mechanics' Experience .....	3-2
3.3 Approach to Diagnostics .....	3-5
3.4 System Specific Details .....	3-7
3.5 Additional Comments .....	3-8
4. DESIGN OF GENERALIZED DIAGNOSTIC METHODS .....	4-1
4.1 Overview .....	4-1
4.2 Diagnostic Procedures Requirements .....	4-2
4.3 Generalized Test Procedures .....	4-6
5. POTENTIAL CARB ACTIONS TO INCREASE DIAGNOSTICS EFFECTIVENESS .....	5-1

APPENDIX A

APPENDIX B



LIST OF TABLES

		<u>Page</u>
2-1	Key to Manufacturer-Recommended Diagnosis Procedures .....	2-3
2-2	Possible Causes of Emissions Test Failures .....	2-6
2-3	Diagnosis Procedures for Air Injection Systems .....	2-7
2-4	Diagnosis of Toyota Closed-Loop Air Injection .....	2-10
2-5	Diagnosis of EGR Systems .....	2-11
2-6	Diagnosis Procedures for Open-Loop Carburetors .....	2-14
2-7A	Diagnosis Procedures for Closed-Loop Carburetor .....	2-16
2-7B	Diagnosis Procedures for Chrysler Closed-Loop Carburetor	2-18
2-8	Diagnosis Procedures for Closed-Loop Fuel Injection .....	2-20
2-9	Diagnosis Procedures for Closed-Loop EFI Systems .....	2-21
2-10	Diagnosis of Catalyst System .....	2-24
3-1	Experience of Mechanics Surveyed .....	3-3
4-1	Emissions Failures Due to Intentional Malperformance .....	4-3
4-2	Emissions Failures Due to Intentional Malperformance .....	4-4
4-3	Basic Requirements for Diagnostic Method .....	4-8
4-4	Secondary Air Systems With Air Pump .....	4-9
4-5	Diagnosis of EGR Systems .....	4-13
4-6	Closed-Loop System Performance Check and Oxygen Sensor Check .....	4-16
4-7	Test Results From System Performance Check .....	4-17
4-8	Diagnostic Method for Feedback Carburetors .....	4-19
4-9	Diagnostic Method for Bosch K-Jetronic Fuel System .....	4-21
4-10	Diagnostic Method for Electronically Fuel-Injected Systems .....	4-23
4-11	Trouble Codes for C-4 On-Board Diagnostics .....	4-24
4-12	Preliminary Recommendations for Catalyst System Diagnostic .....	4-26





LIST OF FIGURES

	<u>Page</u>
2-1 Comparison of Multiple Indicators of Catalyst Poisoning .....	2-26
4-1 Schematic of Secondary Air System .....	4-11
4-2 Schematic of EGR Systems .....	4-15
4-3 Schematic of Bosch Mechanical Fuel-Injection System .....	4-22



## 1. INTRODUCTION

Emission standards for model year 1980 and later cars have required many auto-manufacturers to employ sophisticated emission control systems with "three-way" catalysts. Such catalysts require careful control of engine operating parameters to obtain optimum emission control. Each manufacturer has developed alternative emission control systems that, while often similar in concept, are substantially different in design and construction. Many of these emission control systems utilize electronic controls that link the various individual components together to operate as an integrated system. The resulting variety of alternative systems has strained the ability of the service sector to diagnose and repair malfunctions, as they have made traditional trial and error methods of analyzing engine and emission control system malfunctions virtually impossible. To aid mechanics diagnose such systems, manufacturers have developed separate specialized diagnostic equipment and testing procedures, but the equipment varies by individual vehicle type and model year.

Since it appears questionable whether the service industry can rapidly adapt to this changing environment, the California Air Resources Board (CARB) has contracted EEA to: (1) review current manufacturer-recommended diagnostic procedures for identifying emission control malfunctions; (2) survey diagnostic techniques used in the field; and (3) develop and recommend a set of standardized diagnostic procedures for use by service industry mechanics. The scope of the effort was restricted to three-way catalyst cars, while diagnosis of malperformance was required for:

- The EGR system
- The Secondary air system
- The fuel system
- The catalyst

This report documents EEA's efforts under the first Phase of this contract and presents generalized diagnostic methods applicable to a wide variety of cars. The validation of these methods is performed in Phase II of the contract, and is documented in a companion report.

Section 2 of this report provides our detailed review of current manufacturer recommended methods for diagnosing malfunctions in the emission control system. These methods provide a baseline from which the generalized diagnostic procedures were developed. The CARB had provided a list of 17 cars as a sample representing a broad spectrum of emission control systems. EEA obtained repair manuals for 16 of these vehicles (one repair manual was prohibitively expensive and the recommended methods were almost identical to those for several other cars in the sample) and organized the manufacturer recommended methods for diagnosis into groups featuring common or similar technological characteristics. The data is presented in a series of tables that are intended to exhibit the similarities and differences in manufacturer recommended test methods.

Section 3 of the report presents a summary of the results of the survey of field mechanics conducted by J.D. Power. The survey was performed to identify both the procedures used and problems faced by mechanics in the field when diagnosing three-way catalyst cars with emission control system malperformances. The sample of mechanics was small and the survey should not be viewed as a formal statistical one, but as one where the results can provide some insight into mechanics' concerns. The purpose of the survey was to focus the generalized diagnostic procedures developed in this effort towards mechanics' needs. The detailed results of the survey have already been presented to the CARB separately; only a summary of the results are provided in this report.

Section 4 details the generalized procedure developed by EEA as well as the rationale employed in the development of the generalized procedures.

These procedures are based on the fact that, although 3-way catalyst emission control systems vary widely in mechanical details, they are based on some fundamentally similar concepts. The diagnostic methods presented here are not intended to replace the manufacturers diagnostics, but, rather, to supplement them by providing the mechanic with a few simple tests, requiring no special tools, that can diagnose those emission control system malperformances having potentially large impact on emissions. Moreover, the methods presented here are not in a form that can be given directly to mechanics, but provide enough information for the development of a service manual.

EEA also recognizes that diagnostic methods based on existing emission control systems alone will not solve all of the mechanics problems in diagnosing malperformances. Accordingly, in Section 5 we suggest other remedial measures that can be independently pursued by the CARB to aid mechanics.



## 2. REVIEW OF MANUFACTURER RECOMMENDED DIAGNOSTIC PROCEDURES

### 2.1 INTRODUCTION

As a first step towards the development of standardized diagnostic procedures for three-way catalyst equipped cars, a detailed review of manufacturer recommended diagnostic procedures was undertaken by EEA. The CARB had established a reference list of 17 vehicles representing the spectrum of emission control technology utilized in current vehicles. The survey of manufacturer recommended procedures was based on the methods recommended in their repair manuals for the 17 vehicles specified by the CARB. In this section of the report, EEA has organized the emission control technologies employed in the reference list of cars into groups that employ similar emission control strategies and reviewed the diagnostics recommended for each group. The results of the review are presented in a tabular format, where the essential features of each manufacturers' diagnostic procedure are highlighted.

The review was limited to diagnostics of malperformances in the:

- EGR system
- Secondary air system
- Fuel system
- Catalyst system

In addition, EEA has reviewed only those parts of the fuel system that are specially designed for emission control in conjunction with three-way catalysts. This is because many of the components of the fuel system relate only to fuel delivery, not to emission control. The study methodology assumes that the procedures for dealing with malfunctions for such components are widely understood as they have been available for many years. Hence, diagnostics and repair methods for malfunctions

such as carburetor idle-mixture, sticky choke or binding throttle linkages are not the subjects of this study although any of these malfunctions can induce significant increases in emissions. Since the study of diagnostic methods and repair of these malfunctions would result in essentially duplicating BAR developed diagnostics, the study limitations were chosen to maximize our efforts to develop diagnostics for new three-way catalyst related emission control technology.

Table 2-1 presents an overview of the systems employed in the reference list of vehicles. (One 1980 GM car was eliminated from study because it used an early version the GM C-3 emission control system. This version was subsequently updated in the 1981 and later model year cars which are analyzed in this report.) Note that four of the cars -- Volvo, Audi, VW and Peugeot --utilize the Bosch Continuous Injection System (CIS) with the three-way catalyst. The Bosch CIS is identical in design and operation in each of the four vehicles and diagnostic procedures for such vehicles are grouped into a single table.

Table 2-1 also shows the current status of manufacturer's guidance to mechanics for diagnostics on an emissions failure. Surprisingly, the GM Chevette shop manual was the only one to provide mechanics a listing of possible causes of emissions failures for HC, CO, and NO<sub>x</sub>. Other manuals such as the one for Toyota and Ford provide some guidance on specific malperformances or warnings on secondary air division, but most manuals provide no guidance whatsoever to mechanics on potential causes for emissions failures. All manuals provide diagnostics for driveability related defects -- e.g., surge, stumble, failure to start, backfire -- which may, in some cases, lead to correction of an emissions related failure. The Fiat manual was the exception as it provided no diagnostic methods at all. It is likely that EEA obtained the wrong manual, but since Fiat is currently closing down its North American operations, we were unable to obtain further literature from Fiat.



TABLE 2-1  
KEY TO MANUFACTURER-RECOMMENDED  
DIAGNOSIS PROCEDURES

<u>Vehicle</u>	<u>Guidance on Emissions Failure</u>	<u>Fuel System</u>	<u>Air System</u>	<u>EGR</u>	<u>Catalyst</u>
GM 1.6L	Yes Figure 1	CL Carburetor Table 1	Pulse Air Table 6	BP Table 8	TWC Table 9
GM 3.8L	No	CL Carburetor Table 1	Air Pump Table 6	BP Table 8	TWC/OX Table 9
Chrysler 2.2L	No	CL Carburetor Table 2	Air Pump Table 6	Ported Vacuum Table 8	TWC/OX No Procedures
AMC 2.5L	No	CL Carburetor Table 1	--	BP Table 8	TWC No Procedures
Toyota	Yes	OL Carburetor Table 3	CL Air Pump Table 7	BP Table 8	TWC No Procedures
Ford 1.6L	Warning on Secondary Air Diversion	OL Carburetor Table 3	Air Pump Table 6	BP Table 8	TWC/OX Table 9
Toyo Kogyo	No	OL Carburetor Table 3	Air Pump Table 6	--	TWC/OX Table 9
Volvo/Audi/ VW/Peugeot	No	CL Bosch CIS Table 4	--	--	TWC No Procedures
Saab Turbo	If high HC, EGR System	CL Bosch CIS Table 4	--	On/Off Table 8	TWC No Procedures
Ford 5.0L	Warning on Secondary Air Diversion	CL TBFI (EFI) Table 5	Air Pump Table 6	Sonic Table 8	TWC/OX Table 9

TABLE 2-1 (cont'd)

<u>Vehicle</u>	<u>Guidance on Emissions Failure</u>	<u>Fuel System</u>	<u>Air System</u>	<u>EGR</u>	<u>Catalyst</u>
Nissan 2.8L	No	CL EFI Table 5	--	Electronic Table 8	TWC Table 9
Nissan 2.0L	No	CL EFI Table 5	--	Ported Vacuum Table 8	TWC Table 9
Fiat 1.5L*	--	CL EFI	--	--	TWC

---

\*No diagnosis procedures given

The Chevette manual provides the most detailed chart for guidance on emissions failure and we have, therefore, reproduced it in Table 2-2. However, even this chart appears to have been formulated prior to introduction of three-way catalyst cars. Note that no "closed-loop" system failures are listed as possible causes of high HC or CO, even though such failures cause much larger increases in these pollutants, both at idle (I/M test) and over the FTP, than some of the failures listed in Table 2-2. This lack of specific guidance may account, in part, for earlier CARB findings that mechanics are unable to diagnose and repair the new three-way catalyst system.

The manufacturer recommended diagnostic methods for each of the four subsystems -- Secondary Air, EGR, Fuel, and Catalyst -- are presented below.

## **2.2 SECONDARY AIR SYSTEMS**

Secondary Air Systems can be grouped by technology into systems using an air pump and those using a pulse air valve. Air Pump systems are used in conjunction with three-way catalysts primarily by domestic manufacturers. Most foreign manufacturers, especially European ones, either do not use any secondary air at all or else utilize pulse air systems. The only domestic vehicle using a pulse air system currently is the Chevette 1.6L, while most other domestic vehicles use air pumps. Toyota is the only manufacturer that utilizes "closed-loop" secondary air systems where the air pump output is modulated by the oxygen sensor. Accordingly, the diagnostic method for Toyota vehicles are described separately.

Table 2-3 presents the diagnosis of air pump equipped and pulse air valve equipped secondary air systems. The air pump systems consist of:

- An air pump driven by the engine
- A "diverter valve" that can divert the air to atmosphere under vacuum activation

TABLE 2-2

POSSIBLE CAUSES OF EMISSIONS TEST FAILURES

Excessive Emission	Explanation	Possible Causes
Hydrocarbons (HC)	Excessive hydrocarbons are caused by an air/fuel mixture that is not burning completely.	<ul style="list-style-type: none"> <li>● Engine not at normal operating temperature</li> <li>● Disconnected, obstructed, leaking, or mis-routed vacuum hoses</li> <li>● Vacuum leaks</li> <li>● Maladjusted idle speed</li> <li>● Maladjusted idle mixture — if plugs are removed</li> <li>● Maladjusted initial spark timing</li> <li>● Spark plugs, wires or distributor cap</li> <li>● Improper operation of AIR or Pulsair system</li> <li>● Lead contamination of catalytic converter (check for absence of filler neck restrictor)</li> </ul>
Carbon monoxide (CO)	Excessive carbon monoxide emissions are due to a mixture that is rich.	<ul style="list-style-type: none"> <li>● Engine not at normal operating temperature</li> <li>● Maladjusted idle mixture if plugs are removed</li> <li>● Improperly adjusted/sticking choke</li> <li>● Stuck PCV valve or obstructed PCV hose</li> <li>● Lead contamination of catalytic converter (check for absence of filler neck restrictor)</li> <li>● Improper operation of AIR or Pulsair system</li> <li>● Leaking carburetor fuel passages or gaskets</li> <li>● Carburetor float level</li> <li>● Stuck carburetor power piston</li> <li>● Restricted air cleaner element</li> </ul>
Oxides of nitrogen (NOx)	Excessive oxides of nitrogen are generally due to high temperatures in the combustion chamber.	<ul style="list-style-type: none"> <li>● Obstructed/leaking/misrouted vacuum lines</li> <li>● Improper operation of the EGR system</li> <li>● Incorrect EGR valve for engine type</li> <li>● Plugged EGR passages</li> <li>● Inoperative Thermac</li> </ul>

\*Excessive emissions of both hydrocarbons and carbon monoxide are related to an extremely rich air/fuel mixture. A rich air/fuel mixture increases CO emissions, but if the mixture is too rich, it will not burn completely. This unburned fuel contributes to high hydrocarbon emissions. Check for possible causes as stated in the HC and CO section. Check co-related causes first.

SOURCE: 1981 Chevrolet Chevette Shop Manual, p. 6E-6.

TABLE 2-3  
 DIAGNOSIS PROCEDURES FOR AIR INJECTION SYSTEMS  
 (Except Toyota Closed-Loop AI)

	<u>Air Pump</u>	<u>Pulse Air</u>
Application:	GM 3.8L, Chrysler 2.2L, Ford 1.6L, Toyo Kogyo, Ford 5.0L	GM 1.6L
Functional Check	<ol style="list-style-type: none"> <li>1. Physical inspection - pump, belt, excessive noise, hoses and vacuum lines for deterioration, vacuum hose routing</li>   <li>2. Check valve               <ol style="list-style-type: none"> <li>a) diagnosis: inoperative pump and/or heat failure symptoms</li> <li>b) check by blowing through valve</li> </ol> </li>   <li>3. Air management valve(s) - operational check               <ol style="list-style-type: none"> <li>a) To exhaust manifold during cold-start</li> <li>b) To catalyst after warm-up</li> <li>c) Diversion to atmosphere/air cleaner during deceleration or closed-loop system failure</li> </ol> </li> </ol>	<ol style="list-style-type: none"> <li>1. Physical inspection:               <ol style="list-style-type: none"> <li>a) noise (hiss) - hoses and/or check valve</li> <li>b) heat failure - check valve</li> </ol> </li>   <li>2. Apply vacuum upstream of check valve and measure time rate of vacuum leakage. Replace if valve does not hold vacuum for 2 seconds.</li> </ol>
Notes:	<ol style="list-style-type: none"> <li>1. Function may be checked during normal warm-up by removing appropriate hoses</li> <li>2. Electrically operated valves checked via disconnection of solenoids</li> <li>3. Vacuum control valves may be operated by applied vacuum signals.</li> </ol>	

- A "switch valve" that supplies air to the exhaust manifold under cold conditions and switches the air to the oxidation catalyst (in TWC/OC catalyst systems) or to the atmosphere (in TWC only catalyst systems)
- A "check valve" that prevents blow back of engine exhaust gases into the air supply hoses
- Electrical or thermal vacuum switches to turn on this control vacuum

The diagnostic method begins with a physical inspection of the belts and hoses connected to the air pump. "Check valve" operation is evaluated by blowing through the valve and confirming that air flows only in one direction. Diverter valve and switch valve operation may be checked by removing appropriate hoses to confirm that air is supplied to the exhaust manifold during cold-start and to the catalyst after the engine is warmed up. (All cars in the reference list utilizing air pumps also utilized a TWC/OC catalyst system.) Since both check and switch valves are vacuum activated, manufacturers recommend checking the vacuum hose connections and the presence of vacuum at the valves under appropriate conditions, as described in the table.

Pulse air systems were represented by single model in the reference list --the Chevette. The only checks were visual inspection and checks for hissing noises (indicative of check valve failure). The only diagnostic for the check valve was through application of a vacuum. EEA studied manufacturer recommended diagnostic procedures for other vehicles using pulse air (e.g., the Chrysler 2.6L) and found essentially similar recommendations.

Toyota's 1.8L engine employs a unique secondary air system that is modulated by the computer. The computer utilizes the oxygen sensor signal to modulate vacuum to the diverter valve causing intermittent dumping of air. Thus, all functional checks applicable to conventional air pump systems must be performed and the intermittent modulation of the air

supply checked as well. Table 2-4 shows the recommended diagnostic procedures for the Toyota. Note that the catalyst is provided with temperature sensor that causes the computer to divert air under overtemperature conditions.

### 2.3 EGR SYSTEMS

EGR systems were found on all cars in the reference except for three cars equipped with the Bosch CIS fuel injection system. One other vehicle the Saab Turbo -- was equipped with the Bosch CIS system and a simple on-off EGR system.

All EGR systems share the following common performance criteria:

- EGR off when the engine is cold
- EGR off at idle
- EGR off when engine is at wide-open throttle.

All EGR systems studied are vacuum activated and, hence, the third condition is automatically met as there is no vacuum at wide-open throttle. Vacuum is cut-off to the EGR valve at cold engine temperature by a thermal vacuum switch (TVS) or an electrical vacuum solenoid activated by the computer. In back-pressure EGR systems, vacuum is modulated by a back-pressure sensor that increases EGR flow proportionally with engine load, so that there is no EGR at idle. In ported-vacuum systems, the EGR vacuum is supplied from a specially constructed port near the throttle blades so that the port is not exposed to engine vacuum at idle. In computer-controlled EGR systems, the control vacuum is modulated electrically by the computer, but the remainder of the EGR system is identical to ported vacuum systems.

Diagnostics for all EGR systems follow similar guidelines, as shown in Table 2-5. The EGR diaphragm is mechanically checked for free-movement. The presence of vacuum at the EGR control port is measured at some non-

TABLE 2-4

DIAGNOSIS OF TOYOTA CLOSED-LOOP AIR INJECTION

Air Injection Diagnosis

1. Physical and functional checks (see Table 2-3)

Note: air bypass at cold start

2. Check for air fluctuation at bypass hose  
(normal operating temperatures)
3. Check catalyst over-temperature protection
  - a) Short pins TWC/E of service connector (near ignition coil inside engine compartment) and check for continuous air bypass (simulates over-temp)
  - b) Measure resistance of catalyst temperature sensor

Note: After 1-3, vacuum and mechanical components are functional

EGO Sensor Test

1. After completing air injection diagnosis, connect voltmeter to service connector pin O<sub>x</sub> and check for fluctuating voltage
2. If fixed voltage or fewer than 8 fluctuations in 10 seconds:
  - a) Check (or recheck) air injection components, hoses, wiring;
  - b) if a) okay, replace EGO sensor

ECM - No diagnostics provided



TABLE 2-5

## DIAGNOSIS OF EGR SYSTEMS

<u>Type/ Application</u>		<u>NO Failures x Noted</u>	<u>Driveability Complaints Noted</u>	<u>Diagnosis Procedures*</u>
Back-pressure	GM 1.6L	Yes	No	1. Check hose routing
	GM 3.8L	No	No	2. Check vacuum signal hose (carburetor to EGR valve)
	AMC 2.5L	No	No	- obstruction
	Toyota	No	No	- measure vacuum supplied
	Ford 1.6L	No	Yes	3. Check free movement of EGR diaphragm
				4. Ford
				- apply vacuum to control port; valve should not hold vacuum
				- check for EGR passage obstruction
				a) elevate backpressure by partially blocking exhaust
				b) apply control vacuum and verify engine roughness at idle (high EGR rates)
				5. TVS (if present) remove and check opening in heat bath
				6. AMC - check valve movement during rapid deceleration

2-11

\*Procedures generally applicable across manufacturers, although specific implementations may vary. Major differences in procedure are noted.

TABLE 2-5  
(continued)

<u>Type/ Application</u>		<u>NO Failures X Noted</u>	<u>Driveability Complaints Noted</u>	<u>Diagnosis Procedures*</u>
Ported Vacuum	Chrysler 2.2L	No	No	1. Physical inspection as for back-pressure system.
	Nissan 2.0L	No	No	2. Check movement of EGR valve during rapid deceleration (Chrysler) 3. Check valve movement with externally applied vacuum signal (Chrysler). Check movement at high idle with cold <u>and</u> warm engine (Datsun). 4. Coolant temperature valve checked in cold temperature bath 5. Simplified fault tree given for determining component problem (Chrysler)
SONIC	Ford 5.0L	No	No	1. EEC system check (see Table 5) 2. Physical and functional check as for ported vacuum system
Electronic Modulation	Nissan 2.8L	No	No	1. ECCS check (see Table 5) 2. Physical and functional check as for ported vacuum system

\*Procedures generally applicable across manufacturers, although specific implementations may vary. Major differences in procedure are noted.

idle condition, and the absence of vacuum at idle is checked. In back-pressure systems, the exhaust is partially blocked and vacuum applied to the EGR valve from an external vacuum source so that the presence of EGR can be inferred from engine roughness. For a ported-vacuum system, the same test can be performed without any exhaust blockage. In computer-controlled systems, the lack of appropriate vacuum signals at the EGR valve indicates malperformance of either the electrically controlled vacuum solenoid or some fault with the computer; check out of computer functions is described in the next subsection.

## 2.4 FUEL SYSTEMS

Unlike EGR and secondary air systems, fuel systems display considerable diversity in both technology as well as in recommended diagnostics. Technologically, fuel systems can be grouped into the following categories:

- Open-loop carburetors
- Mechanical fuel injection (Bosch CIS)
- Electronic fuel injection

The first category, open-loop carburetors, is essentially similar to conventional carburetors on pre-three-way catalyst cars and most diagnostics are identical to those specified for conventional carburetors. Table 2-6 shows the recommended diagnostics for such carburetors and the principal additions to the diagnostic method is due to the presence of the high altitude compensation (HAC) valve. The valve is usually checked through the opening or closing of vacuum passages at high altitude.

Closed-loop carburetors employ an electrically operated solenoid that modulates air fuel ratio. In most closed-loop carburetors, no electrical signal to the carburetor results in a rich-mixture while a continuous signal to the solenoid results in a lean mixture. The computer modulates the electrical input to the solenoid and the duty cycle of this input is determined by the oxygen sensor. During warmup, when the oxygen sensor

TABLE 2-6

DIAGNOSIS PROCEDURES FOR OPEN-LOOP CARBURETORS

Application: Toyota (closed-loop air injection)  
 Ford 1.6L  
 Toyo Kogyo

Diagnosis Procedures  
 (All):

1. Troubleshooting chart keyed to driveability/  
 fuel economy complaint (only).
2. Conventional carburetor diagnosis/repair
  - a) Physical inspection - free movement of  
 accelerator, choke linkage, etc.
  - b) Off-vehicle inspection - cleanliness,  
 check for blokage in fuel passages,  
 check float, needle valve, fuel pump  
 diaphragm, etc.
3. Idle speed and timing check
4. Idle mixture adjustment via lean-drop method
5. High altitude compensation (HAC) valve
  - Toyota:
    - 1) Determine high/low altitude  
 position of HAC by blowing  
 through port on top of valve.  
 Closed passage is low altitude  
 position.
    - 2) At high altitude, timing retarded  
 from 15° to 8° BTDC when distributor  
 HAC subdiaphragm hose is disconnected/  
 plugged.
  - Ford:
    - 1) Connect vacuum gauge to air inlet  
 on valve.
    - 2) Normal conditions: vacuum present  
 above 3500 ft.
  - Toyo  
 Kogyo:
    - 1) Remove air cleaner and start engine.
    - 2) Blind slow port on air hone; idle rpm  
 drop at high altitude (above 1600 ft.)

is not activated, the computer provides a fixed predetermined duty cycle to the solenoid.

Manufacturer-recommended diagnostics for closed-loop carburetors essentially utilize the dwell meters' ability to read the duty cycle under different operating conditions. GM is currently the only manufacturer to provide extensive on-board diagnostics that can be accessed without any special tools by the mechanics. Procedures for GM cars are based on utilizing the on-board diagnostics. Table 2-7A provides GM recommended methods (the AMC 2.5L is built by GM) for diagnosing the fuel system and computer. GM also provides a system performance check if the diagnostics are not working, based on connecting the dwell meter to the carburetor solenoid and observing its behavior. Tests include making the carburetor meter rich by choking the air flow and checking dwell meter response (for fixed low dwell condition) or by leaning out the mixture (for fixed high dwell condition). The system that is performed at high speed idle (@3000 rpm) to insure fully warmed-up operation.

Chrysler utilizes the same type of control system and a very similar, although slightly more innovative test method. With the dwell meter attached to the solenoid, Chrysler recommends disconnection of the oxygen sensor harness. The human body is then used as a surrogate oxygen sensor -- with a finger inserted into the harness, the positive terminal of the battery is touched with the other hand, indicating a rich mixture. If the system is operating correctly, the computer drives the engine lean, causing the dwell meter to read high and engine rpm to drop. When the harness is ground, the computer drives the engine rich with exactly opposite effects. Chrysler's recommended diagnostic procedure is outlined in Table 2-7B.

The Bosch (CIS) Fuel Injection System is conceptually similar to a closed-loop carburetor in the operating principles of the closed-loop system. Just as the solenoid modulates the base air-fuel ratio in the feedback

TABLE 2-7A

DIAGNOSIS PROCEDURES FOR CLOSED LOOP CARBURETOR  
(GM C-4 System Only)

Application:

GM 1.6L            GM 3.8L            AMC 2.5L

Inspection Procedure:

1. Activate on-board diagnostics (displayed on check engine light)
  - (a) First trouble code (code 12) indicates diagnostics functional
  - (b) Read trouble code and refer to code-specific fault trees (~11 pages) for detailed diagnosis procedures.
2. If no trouble code, operate engine (up to 15 min.) to activate check engine light and store trouble code. Then repeat Step 1.
3. If diagnostics not functional or no trouble code, use System Performance Check.

Diagnosis Procedure:

Equipment - Dwell meter, tachometer, digital voltmeter

System Performance Check

1. Performance Diagnosis
  - (a) RPM drop when M/C solenoid disconnected (@3000 rpm) <100 rpm indicates carburetor calibration problem or evap. cannister
  - (b) Reconnect M/C solenoid and attach dwell meter. If dwell is:
    - Varying    Then check dwell at 3000 rpm. If not spec., check air management, carburetor calibration. Else, system okay.
    - Fixed      If low dwell, step 2(a)  
If intermediate dwell, step 2(b)  
If high dwell, step 2(c)

TABLE 2-7A  
(continued)

2. Component Diagnosis

(a) Choke engine at idle. Dwell increases - Check for air or vacuum leak, EGR operation, vacuum hose routing

No dwell change - Faulty EGO sensor, ECM, or wiring harness.

(b) Check TPS movement and for low coolant

Check coolant temp sensor resistance

If no dwell change with coolant sensor shorted, then faulty EGO sensor or wiring, coolant sensor wiring, or ECM/ECM wiring

(c) Lean engine via vacuum leak. Dwell changes - carburetor calibration

No dwell change - faulty EGO sensor or ECM

3. Repair, repeat from Step 1.

TABLE 2-7B

DIAGNOSIS PROCEDURES FOR CHRYSLER  
CLOSED-LOOP CARBURETOR

Application: Chrysler 2.2L

- Diagnosis Procedure:
1. Equipment - dwell meter, timing light, digital voltmeter
  2. Verify that Electronic Spark Advance Computer (ESC) is functional
    - a) If vehicle won't start, diagnose ignition system, then continue
    - b) Check spark
  3. M/C Solenoid test - replace if fails a) and b)
    - a) Disconnect (open) @2000 rpm: rpm rise
    - b) Reconnect, ground ECU pin (#15): rpm drop
  4. ECM test - replace if fails c) and d)
    - a) Connect voltmeter to M/C solenoid
    - b) Disconnect EGO sensor harness
    - c) Ground sensor harness: voltage >9V  
rpm should rise
    - d) Insert finger into EGO harness; with other hand touch positive terminal of battery: voltage <3V  
rpm should drop
  5. EGO Sensor test - replace if fails b) and c)
    - a) Connect voltmeter to ECM output to M/C solenoid
    - b) Choke engine at idle: voltage <3V
    - c) Lean engine via vacuum leak: voltage >9V



carburetor, a "frequency valve" modulates the fuel metering pressure which determines the quantity of fuel injected. Table 2-8 outlines the recommended methods for these vehicles with the Bosch CIS system. Note that Saab, Audi, and VW utilize a specialized tester that cycles the computer with the engine off. However, Volvo provides a diagnostic method that utilizes a dwell meter monitoring the frequency valve's input signal. Conceptually, the diagnostic method is identical to the system performance check utilized by GM for the feedback carburetor (Table 2-7A) except that in this system, high dwell is used to drive the mixture rich and low dwell to drive the mixture lean --i.e., the opposite of the duty cycle used in carburetors. Volvo is unique in that it recommends monitoring CO ahead of the catalyst -- a special sample line is provided on Volvos -- to determine if the air-fuel mixture is actually rich or lean.

Closed-loop electronic fuel injection systems offer the most specialized diagnostic procedures of all fuel systems surveyed. The Ford 5.0L engine equipped with Central Fuel Injection (CFI) requires a special test unit called the "Rotunda Tester" which plugs into the existing wiring harness on the car. The tester automatically activates various computer circuits in sequential order and monitors engine response to check the different emission control components. The Nissan 2.8L engines also utilizes a special tester, the "ECCS Analyzer," to perform a system check similar to the one performed by the Ford "Rotunda Tester." However, both the 2.8L and Nissan 2.0L provide an inspection lamp on the engine control unit (computer) that flashes whenever the closed-loop system is operating. Diagnostic procedures for the Nissan 2.0L engine utilize this inspection lamp and are detailed in Table 2-9. Note the conceptual similarity with Chrysler test for feedback carburetors. Instead of reading the dwell meter response, the inspection lamp provides the visual clue to checking closed-loop operation. As with the Chrysler test, Nissan recommends the oxygen sensor be disconnected and the harness grounded to drive the system rich. In the case of the Nissan, correct operation of the computer would

TABLE 2-8

DIAGNOSIS PROCEDURES FOR CLOSED-LOOP FUEL INJECTION  
(Bosch K-Jetronic CIS)

Application: Volvo, VW, Saab Turbo, Peugeot, Audi

Recommended Equipment: Volvo - CO analyzer, high impedance dwell meter  
Saab - Bosch KDJE-7453 dwell meter, CO analyzer  
Audi - Siemens 451 or VAG 1367 testers (only)

Diagnosis Procedure:

Volvo

Saab Turbo/Audi/VW

- |                                                                                                                                                                                                                                                                                                                                                                                                                                                                                                                                                                                                                                                                                                                                                                                                                                                                                                                                                   |                                                                                                                                                                                                                                                                                                                                                                                                                                                                                                                                                                                                                                                                                                                                                                                                                                                                                                                                                                                                                                                          |
|---------------------------------------------------------------------------------------------------------------------------------------------------------------------------------------------------------------------------------------------------------------------------------------------------------------------------------------------------------------------------------------------------------------------------------------------------------------------------------------------------------------------------------------------------------------------------------------------------------------------------------------------------------------------------------------------------------------------------------------------------------------------------------------------------------------------------------------------------------------------------------------------------------------------------------------------------|----------------------------------------------------------------------------------------------------------------------------------------------------------------------------------------------------------------------------------------------------------------------------------------------------------------------------------------------------------------------------------------------------------------------------------------------------------------------------------------------------------------------------------------------------------------------------------------------------------------------------------------------------------------------------------------------------------------------------------------------------------------------------------------------------------------------------------------------------------------------------------------------------------------------------------------------------------------------------------------------------------------------------------------------------------|
| <ol style="list-style-type: none"> <li>1. Cold-start with EGO disconnected<br/>Connect dwell meter to test socket             <ol style="list-style-type: none"> <li>a) Check open-loop baseline of frequency valve (dwell spec.)</li> </ol> </li> <li>2. Warm-up, check/adjust idle speed             <ol style="list-style-type: none"> <li>a) Attach CO analyzer <u>ahead</u> of catalyst at test fitting</li> <li>b) Abnormal CO - adjust FI idle mixture</li> </ol> </li> <li>3. Reconnect EGO Sensor             <ol style="list-style-type: none"> <li>a) Normal: CO &lt;1%, slight drop in dwell (varying)</li> <li>b) Else see below</li> </ol> </li> <li>4. Dwell normal/CO &gt;1%, check EGO sensor mounting, exhaust leaks. Check mechanical FI</li> <li>5. No dwell change<br/>Faulty EGO sensor or ECM</li> <li>6. Low dwell/CO &gt;1%<br/>Faulty Frequency Valve</li> <li>7. High dwell/CO &gt;1%<br/>Faulty EGO sensor</li> </ol> | <ol style="list-style-type: none"> <li>1. Connect test instrument to test socket on relay panel and power supply (Saab); connect instrument to EGO test terminal and insert manually switched test relay to fuel pump relay socket (Audi) (instruments simulate engine operation)</li> <li>2. Engine off             <ol style="list-style-type: none"> <li>a) Frequency valve audible; else check valve and wiring. If okay, replace ECM</li> <li>b) Check open-loop duty cycle. If ~60%, okay. Else, faulty EGO sensor or ECM/ECM wiring harness</li> <li>c) Ground EGO sensor harness - duty cycle &gt;75%, else faulty ECM/ECM harness</li> <li>d) Disconnect ground - if duty cycle drops below 50% and returns to 60%, okay. Else faulty ECM/ECM harness</li> </ol> </li> <li>3. Engine running             <ol style="list-style-type: none"> <li>a) Check full throttle enrichment (turbo only)</li> <li>b) Warm-up until duty cycle varies. If extreme high or low duty cycle, check EGO sensor, ECM and/or ECM harness.</li> </ol> </li> </ol> |
|---------------------------------------------------------------------------------------------------------------------------------------------------------------------------------------------------------------------------------------------------------------------------------------------------------------------------------------------------------------------------------------------------------------------------------------------------------------------------------------------------------------------------------------------------------------------------------------------------------------------------------------------------------------------------------------------------------------------------------------------------------------------------------------------------------------------------------------------------------------------------------------------------------------------------------------------------|----------------------------------------------------------------------------------------------------------------------------------------------------------------------------------------------------------------------------------------------------------------------------------------------------------------------------------------------------------------------------------------------------------------------------------------------------------------------------------------------------------------------------------------------------------------------------------------------------------------------------------------------------------------------------------------------------------------------------------------------------------------------------------------------------------------------------------------------------------------------------------------------------------------------------------------------------------------------------------------------------------------------------------------------------------|

TABLE 2-9

DIAGNOSIS PROCEDURES FOR CLOSED-LOOP EFI SYSTEMS

Application:	Ford 5.0L	Nissan 2.8L	Nissan 2.0L
Recommended Equipment:	Rotunda EEC tester Wiring harness adapter Fuel Pressure Gauge Digital voltmeter	ECCS Analyzer J-28835	Exhaust gas analyzer, tachometer, timing light
Diagnosis Procedure:	<ol style="list-style-type: none"> <li>1. Attach tester to ECM via wiring harness adapter and start engine</li> <li>2. Tester activates EEC components and monitors engine response               <ol style="list-style-type: none"> <li>(a) Sequential test of system by Quick Test flowchart; requires some control of engine operating conditions</li> <li>(b) Service codes indicated on tester panel; produces reference to detailed diagnosis procedure (154 pp.)</li> </ol> </li> <li>3. Components checked:               <ul style="list-style-type: none"> <li>● Battery voltage; sensor reference voltage</li> <li>● Cranking signal (EFI)</li> <li>● TPS</li> <li>● Coolant temperature sensor</li> <li>● Air change, temperature sensor</li> <li>● MAP sensor</li> <li>● Barometric pressure sensor</li> <li>● EGR valve</li> <li>● AC Throttle Kicker</li> <li>● Air management system</li> <li>● Crankshaft position sensor</li> <li>● Ignition module</li> <li>● EGO sensor</li> </ul> </li> </ol>	<ol style="list-style-type: none"> <li>1. Attach tester to ECM via wiring harness adapter and start engine</li> <li>2. Tester performs checks similar to Ford Rotunda</li> <li>3. Components checked:               <ul style="list-style-type: none"> <li>● Ignition</li> <li>● EGR</li> <li>● Fuel Pump</li> <li>● Idle speed control</li> <li>● Battery</li> <li>● Air Flow Meter</li> <li>● Air temperature sensor</li> <li>● Cylinder lead temperature sensor</li> <li>● Knock sensor</li> <li>● Crankshaft position sensor</li> <li>● Road speed sensor</li> <li>● Injector operation (individually)</li> </ul> </li> <li>4. Closed-loop Control               <ol style="list-style-type: none"> <li>(a) Inspection lamp located on ECM flashes with closed-loop system.</li> <li>(b) If not flashing, replace EGO sensor</li> <li>(c) If still not flashing, replace ECM</li> </ol> </li> </ol>	<ol style="list-style-type: none"> <li>1. Physical inspection and/or conventional diagnosis of: battery, ignition system, engine oil and coolant level, fuses, EFI wiring harness, vacuum hoses, etc.</li> <li>2. Check/adjust idle speed and timing on fully warm engine (vacuum spark advance disconnected and plugged)</li> <li>3. Warm-up EGO sensor (run engine at 2000 rpm for ~2 minutes). Check for flashing of inspection lamp on control unit (under-dash)               <ol style="list-style-type: none"> <li>(a) If 3 or more flashes in 10 seconds, then closed-loop system is okay.</li> <li>(b) If lamp does not flash check continuity in control unit/EGO sensor harness; replace or repair as necessary.</li> </ol> </li> </ol>

TABLE 2-9 (cont'd)

- Application: Nissan 2.0L
- Recommended Equipment: ECCS Analyzer J-28835
- Diagnosis Procedure:
4. If continuity exists but lamp does not flash, check EFI control unit:
    - (a) Warm-up EGO sensor at 2000 rpm
    - (b) Disconnect EGO sensor harness and monitor inspection lamp response:
      1. lamp glows when harness is grounded
      2. lamp off when harness is open
    - (c) Replace control unit if response not normal and repeat Step 3, or else continue with Step 5.
  5. With engine off, connect pins 24 and 30 of throttle valve switch harness connector to simulate full-throttle connection. Disconnect EGO sensor harness. Start and warm-up engine. Insert exhaust gas analyzer into tailpipe.
    - (a) If CO <6% at idle, adjust baseline calibration or repair/replace air flow meter and repeat Step 5.
    - (b) If CO >6%, continue with Step 6.
  6.
    - a) If engine runs smoothly, replace EGO sensor. Reconnect throttle switch and EGO harness and check inspection lamp (Step 3).
    - b) If engine runs roughly, check for vacuum leaks and correct as necessary, then check inspection lamp (Step 3).
    - c) If engine runs rough and no vacuum leaks found, adjust baseline calibration as in Step 5(a), then repeat procedure from Step 5.

result in the inspection lamp turning on. Additional steps for diagnosis include a check of throttle position sensor which can influence the operation of the closed-loop system as indicated in Table 2-9.

## 2.5 CATALYST SYSTEM

Unlike the voluminous diagnostics provided for the other systems, little information is provided by any manufacturer on the diagnosis of catalysts. Table 2-10 provides the listing of manufacturer's recommendations for diagnosis of catalyst malperformance -- less than half the vehicles on the reference list had any recommendations regarding the diagnosis of catalysts. Recommended procedures tended to be very simplistic and primarily involved physical examination for damage or substrate meltdown that results in blockage of the exhaust. Nissan utilized a CO check after all other emission control systems were found to be operating properly --i.e., a "last resort" diagnostic.

Since lead poisoning of catalysts results in their failure and none of above tests are useful in determining if the catalyst is poisoned by lead, EEA searched for additional data on diagnosis of catalyst poisoning. Manufacturers were of little help -- however, the EPA recently performed a detailed study of misfueling of cars and utilized three tests:

- Inspecting the filler neck for tampering
- Using a chemical test for identifying lead in the exhaust pipe
- Testing for lead in gasoline.

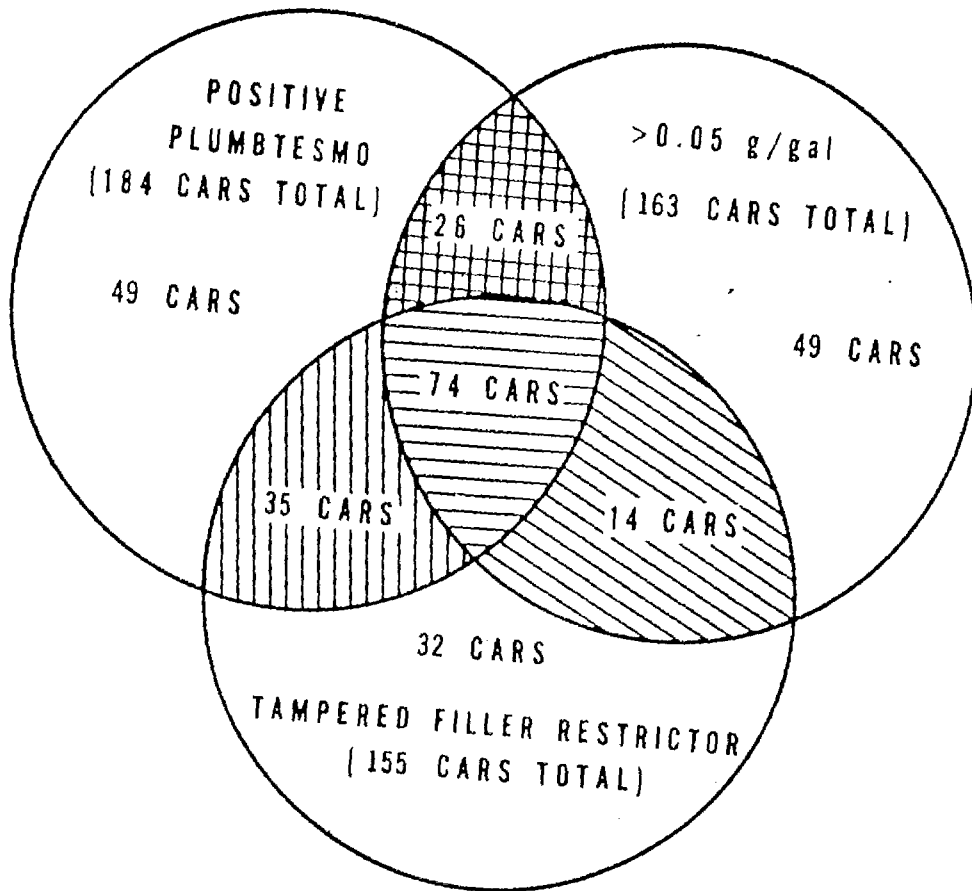
The chemical test used for identifying the lead in the exhaust pipe was the commercially available "Plumbtesmo" test where filter paper soaked in a special solution changes color in the presence of lead. The lead content of the gasoline in the vehicle's tank was checked by withdrawing a sample and checking for lead by the atomic absorption method in the laboratory.

TABLE 2-10  
DIAGNOSIS OF CATALYST SYSTEM

<u>Application</u>	<u>Diagnosis Procedure</u>
GM 1.6L	<ul style="list-style-type: none"> <li>● Noted as possible cause of HC and/or CO failures</li> <li>● Check for absence of filler neck restrictor</li> </ul>
GM 3.8L	<ul style="list-style-type: none"> <li>● Physical inspection of converter canister, exhaust pipes, muffler</li> </ul>
Toyo Kogyo	<ul style="list-style-type: none"> <li>● Physical inspection of canister, test for exhaust leakage</li> </ul>
Audi	<ul style="list-style-type: none"> <li>● If rattle or driveability problem (low power output, idle speed drop, or stalling)               <ul style="list-style-type: none"> <li>- remove</li> <li>- hold up to light and look through to check for melted substrate</li> <li>- tap canister to check for substrate movement</li> </ul> </li> </ul>
Ford 5.0L	<ul style="list-style-type: none"> <li>● Check for exhaust system restriction</li> </ul>
Nissan 2.8L	<ul style="list-style-type: none"> <li>● Physical inspection</li> </ul>
Nissan 2.0L	<ul style="list-style-type: none"> <li>● Warm-up catalyst 4 minutes at 2000 rpm               <ol style="list-style-type: none"> <li>(1) return to idle and measure exhaust CO (after catalyst)</li> <li>(2) normal is &lt;0.3%</li> <li>(3) if &gt;0.3%, check EFI system and repeat (</li> <li>(4) if still &gt;0.3%, replace catalyst</li> </ol> </li> </ul>

The results of the test are displayed in Figure 2-1. Each test failed approximately 175 cars, but the failures were not identical. As can be seen from the figure, only 74 of the vehicles failed all three tests, whereas 279 cars failed at least one test, and 149 cars failed at least two tests. If we assume that only cars failing all three tests were misfueled and their catalyts were poisoned, then any of the three tests results in over a 50 percent error rate. On the other hand, if we assume that vehicles are misfueled if they fail any one of the tests, the maximum detection rate is 66 percent (for the "Plumbtesmo" test). Conversations with EPA field staff revealed that "Plumbtesmo" sample was sensitive to ambient conditions such as humidity and temperature and would be a difficult test to implement for day-to-day use by mechanics. Testing for lead in gasoline is clearly beyond the scope of any mechanic, leaving only the inspection for a tampered filler neck restricter as a viable test for field use. However, based on EPA's test results, it is difficult to make any conclusive comment on its usefulness as a diagnostic tool for catalyts.

FIGURE 2-1



2-26

VEHICLES REQUIRING UNLEADED FUEL (2637 TOTAL)

COMPARISON OF MULTIPLE INDICATORS  
OF CATALYST PERFORMANCE



### 3. SURVEY OF FIELD MECHANICS

#### 3.1 INTRODUCTION

A survey of field mechanics was initiated by EEA in order to understand the procedures currently used by them to repair emission control malfunctions in three-way catalyst cars. The survey also elicited their concerns regarding data availability, usefulness and shortcomings of manufacturers recommendations and difficulties in implementing available procedures. The purpose of the survey was to obtain some insight into mechanics' diagnostic methods so that generalized diagnostic procedures could be designed to address mechanics' abilities and concerns. The resource limitations of the project made it impossible to conduct a formal, statistically valid survey. Rather, this survey was primarily for informational purposes to aid in the design of diagnostic procedures and the data presented here should be construed as indicative of trends.

For the survey, certified Class A mechanics were interviewed about their knowledge of the diagnosis and repair of emission control systems. The interviews were conducted by J.D. Power and Associates using a questionnaire and guidelines developed by EEA. Sixty-three mechanics were interviewed in three cities in California -- Los Angeles, San Diego and San Francisco -- with over half the interviews conducted in Los Angeles, so that geographical differences among mechanics would be apparent. Interviews were restricted to certified Class A mechanics as these credentials are required for mechanics to repair vehicles failing the emission inspection. In order to capture the diversity of mechanics' abilities, the survey sample included mechanics from dealerships, repair chains (such as Sears, K-Mart) and independent repair facilities. All mechanics interviewed had Motor Vehicle Inspection Program (MVIP) or Motor Vehicle Pollution Control (MVPC) experience. Mechanics were individually

interviewed using an open ended questionnaire by representatives from J.D. Power. These interviewers were not trained mechanics, but had general familiarity with emission control systems and were briefed in detail about the performance of these systems by EEA staff. Given the limitations in knowledge and the time constraints facing the interviewers, it was not possible to probe several ambiguous statements by mechanics. Hence, some of the results appear contradictory, but reflect the survey data as collected.

The questionnaire employed by the interviewers provided a logical sequence of queries on the mechanics' background, work experience, general approach to diagnostics, specific information on the four emission control systems of interest (Secondary air, EGR, fuel and catalyst systems) and some general questions to decipher areas where mechanics feel they could use information. The responses of the mechanics were tabulated and reported in detail by J.D. Power in Appendix A of this report. This section summarizes the important results of the survey.

### **3.2 MECHANICS' EXPERIENCE**

Of the sample of 63 mechanics interviewed, 23 worked at dealerships, 25 worked in independent garages and 15 worked at repair chains. The sample was chosen to cover a wide variety of experience levels ranging from five years to over 35 years. The average for the sample was 16.5 years, with about half the sample having an experience range of 5 to 14 years. Additionally, mechanics were asked about how long they were certified by the BAR. Table 3-1 shows the distribution of mechanics in the sample by number of years of BAR certification. Since BAR certification for a MVPC Class A license has been in existence since 1973, the data in Table 3-1 showing 41 percent of mechanics being certified longer than 10 years appears erroneous; however, mechanics may have confused the MVPC license with the more general BAR mechanics license which has been in existence for a much longer time.

TABLE 3-1

EXPERIENCE OF MECHANICS SURVEYED  
 (Number of years with BAR certification)

	<u>Percent</u>
Less than 5 years	22
5-9 years	37
10-14 years	20
15-19 years	10
20-24 years	4
more than 24 years	7

Training and education received by mechanics varies considerably and depends primarily on the type of service facility. New car dealership provide extensive training with classes every few months sponsored by the manufacturer, usually at a school and through local seminars. The training, however, is usually limited to the brand(s) of cars sold at the dealership in which the mechanic is employed. Independent garage mechanics report that their training was at vocational schools, although many of them have had previous experience at dealerships where they received the training mentioned above. On-the-job training depends on the nature of incentive provided by the owner to the mechanic to attend each training sessions.

In general, owners who have invested in service centers with specialized equipment for repair of emission control devices do send their mechanics for training in the diagnostics of emission control systems. Mechanics at chain stores appear to be least trained. Although they have access to the same training seminars as the independents, mechanics at chains are given no time or incentive to attend such seminars. Typically, chain shops did not repair cars with complex emission control systems and hence mechanics saw little point to their learning about such systems.

A second major point made by mechanics was that their best education was from the "hands-on" work that they do rather than from seminars. Typically, mechanics experiment with new systems and learn through experience; since the new three-way catalyst systems are only two to three years old, they are still being repaired (under warranty) at dealerships and hence, independents and chain shop mechanics have not had the exposure that dealership mechanics have to these systems. Most mechanics, but not all, surveyed had some experience in the repair of electronic or "feedback type" emission control systems. The experience and knowledge of dealership mechanics about these systems is readily apparent in their responses to the survey.

### 3.3 APPROACH TO DIAGNOSTICS

Mechanics were queried on their general approach to diagnostics prior to more detailed questioning on specific emission control systems. Questions were asked on:

- Customer contact
- Preliminary check of the vehicle
- Areas of specialization
- Availability of manuals and tools
- Familiarity with the inspection/maintenance test
- Extent of emission control repair performed.

Dealership and chain mechanics rarely, if ever, deal with the customer. Monetary limits and vehicle driveability problems are discussed by a service writer who tells the mechanic what the customer wants or does not want. Independent garage mechanics, on the other hand, often deal with the customer directly and obtain their inputs on driveability problems and the nature of repair work to be performed.

If a vehicle that has failed the I/M test comes in for repair, all mechanics perform a preliminary retest to check the values using an HC/CO analyzer. Los Angeles based mechanics are provided with an inspection sheet that records the emissions readings of the vehicle as well as the emission standards the vehicle must meet before it can be certified. The initial retest used by mechanics is used as an indicator of specific problem areas. Mechanics will, in general, work only on vehicles in which they have some experience. As a result, chain stores often do not work on complex emission controls such as fuel injection systems or feedback carburetors. Since Federal law requires a 5-year, 50,000 mile warranty on emission control systems, many independent garages and chain shops will recommend that owners of vehicles with the more recent complex emission controls take their vehicles to dealerships for warranty service. Mechanics also appear to avoid specific vehicles which have given them great difficulty in the past.

Specialization seems to be widespread among most mechanics. As noted previously, chain shops do little more than tune-ups on vehicles with the conventional emission control systems. Independent garages often have individual mechanics specialize in certain types of systems such as fuel injection or certain makes of cars with relatively more complex emission control systems. Dealership mechanics very obviously must specialize in the vehicle types sold by the dealership, although they receive exposure to other vehicles that are traded in for resale by the dealer. However, many of the dealership mechanics did not know about system peculiarities in late model vehicles other than the ones sold by the dealership primarily because their exposure to other vehicles is limited to the older vehicles traded in by consumers.

The survey reported that mechanics appear generally satisfied with the availability of manuals. This comment must be read in the context of mechanics usually having some areas of specialization in the newer, more complex emission control systems. (Service manuals are required to be present in all certified repair shops according to California regulations.) A few mechanics stated that they would like to see more specific information especially about electronics and some step-by-step information on emission control repair. This is consistent with EEA's finding that current service manuals rarely provide diagnostic guidance to mechanics on emission failures. If the manuals are not sufficient or do not provide the needed information, mechanics will generally call the service department of a dealership or a manufacturer representative for additional information. Mechanics also appear to have some trouble understanding the certification requirements for the I/M test administered in the Los Angeles area (San Francisco and San Diego do not require a retest by the state facility) and, hence, sometimes call the ARB for information on standards for specific types of cars.

Mechanics emphasize that the information in service manuals or troubleshooting charts was secondary to the primary source of information --

experience. Most mechanics found that following the charts was laborious and time consuming and experience generally provides the fastest way to find a problem. Mechanics said that they used the manuals and charts on new or unfamiliar vehicles but few mechanics admit to using a trial and error method for diagnostics. All mechanics uniformly found the stickers or decals under the hood to be very useful -- especially those providing vacuum hose diagrams. Some asked that more information be provided on the sticker like spark plug gap, CO levels and carburetor settings.

Mechanics at chain shops and independents stated meeting the cost limitations, rather than correct and complete repair of the vehicles, are the primary objectives of their work. These mechanics state that they fix only the minimum necessary for a vehicle to pass the emission test. The state imposed repair cost ceiling of \$50 appears to be the prime reasons for this and with labor costs of \$30-\$40/hr., there is little leeway for the mechanic to spend time ensuring the vehicle is up to manufacturer specification. Dealership mechanics, on the other hand, appear to be more willing to restore the car to specifications, possibly because much of their work on emission control is done under warranty. None of the mechanics interviewed stated that a lack of tools hampered their diagnostics, although mechanics at shops equipped with a dynamometer were enthusiastic as they felt more competent in diagnosing cars with NO<sub>x</sub> failures.

### **3.4 SYSTEM SPECIFIC DETAILS**

Mechanics were questioned on their diagnostic approaches to the secondary air, EGR fuel and catalyst systems. The interviewers were provided with the "right" answers to questions relating to understanding of the principles of system operation and the appropriate diagnostic for each system. In most instances, mechanics provided these answers or a "don't know" but in some, ambiguous answers were provided. EEA concludes that mechanics were reluctant to disclose their lack of knowledge of such systems where such ambiguous answers were provided.

It is difficult to further summarize the mechanics' responses to questions on specific systems beyond what is provided in Appendix A of this report. The reader is referred to this section for details on how mechanics fix each specific portion of the system. It became readily apparent that most mechanics are conversant with the diagnosis and repair of EGR systems and secondary air systems equipped with an air pump. Pulse air systems (available on some Japanese vehicles and the Chevette) are poorly understood, although this may reflect the fact that many mechanics may never have worked on cars equipped with such systems. Similar lack of knowledge is displayed by mechanics on "closed-loop" or feedback systems, although it is possible that the terminology may be confusing to the mechanics. Mechanics also appear unfamiliar with differences between mechanical and electronic fuel injection systems. Overall, mechanics tended to have knowledge of either mechanical or electronic fuel injection systems, but not both, reflecting the specialization in the field. Similar lack of knowledge was reported on the newly developed internal diagnostic systems (available on all 1981+ GM cars and some Ford vehicles). Some mechanics responded that feedback carburetors, electronic controls, and internal diagnostics were hard to repair, and many others provided responses that were ambiguous at best, leading EEA to believe that it is likely that those mechanics knew little about such systems. A surprising number of mechanics (75%) claimed that they inspect the catalyst, while several even claimed that they measure CO/HC readings with and without the catalyst (by physically removing the catalyst) to examine if the catalyst is actually functioning or not.

### **3.5 ADDITIONAL COMMENTS**

Mechanics were allowed to make a number of additional comments, which we have grouped into four topic areas.

I/M Test - Many mechanics appear not to know about the exact procedure used on the I/M test, with nearly one-sixth of the sampled mechanics



giving wrong answers to questions about the test. Many mechanics in the Los Angeles area questioned the correctness of the emission readings (primarily because only the L.A. area requires a retest) and reported very negative interaction with test center personnel. Many mechanics feel that Hamilton test personnel were unqualified for their job and performed the test unfairly to obtain a retest fee.

Emission Standards and Control Technology - Mechanics in San Diego and San Francisco mentioned the need for information on exactly what standards were applicable to each vehicle in question. (Mechanics are provided this information in the Los Angeles area.) Some mechanics requested a tag on the vehicle identifying all the emission control equipment that was supposed to be on that vehicle so that outright removal of this equipment could be checked. Others even requested the specifications for the equipment listed.

CARB Information - Some mechanics requested a local CARB office of hotline to obtain necessary information on standards or check on manuals. Others requested the help of the ARB "for general questions" on the test procedure or cost limitations.

Diagnostic Procedure - Most mechanics remain suspicious of standardized diagnostic procedures because they feel cars are too different. Only one mechanic in the sample saw this as a useful idea. In spite of their troubles with feedback control systems, most mechanics did not feel that there was a need for additional diagnostic information. Paradoxically, many mechanics requested that the CARB provide a diagnostic on each vehicle for them. Others felt that, given the \$50 cost ceiling, there was little they could do beyond what they were already doing.



## 4. DESIGN OF GENERALIZED DIAGNOSTIC METHODS

### 4.1 OVERVIEW

In this section, the methodology used to develop generalized diagnostic procedures is detailed and the generalized procedures are presented as a series of tables which outline the steps required to diagnose an emission control system malperformance. It must be emphasized, however, that these tables are not intended to be supplied to mechanics as presented in this report, but should be used as the basic material --together with illustrations or pictorial descriptions -- from which a handbook for mechanics can be developed. A second major point that must be emphasized is that these procedures are not intended to replace existing manufacturer specified procedures, but are intended to supplement them. Thus, questions regarding warranty of emission control systems that impose legal requirements on manufacturers cannot be resolved through the use of the generalized test procedures. The procedures presented in this report, however, provide simple reliable methods that can be used on a wide variety of "closed-loop" three-way catalyst equipped makes and models of vehicles.

Given the wide diversity in emission control systems technology, it was recognized that no generalized procedure could be expected to diagnose every component of the emission control system for every make and model available. Secondly, the development of these procedures was predicated on the assumption that the mechanic was competent on earlier (oxidation catalyst) technology and was therefore, starting from a knowledge base where it was not necessary to explain the basic operating principles of engine components such as carburetors or fuel-injection systems. EEA recognizes that many mechanics do not, for example, understand the operating principles of fuel-injection systems; the objective of the

procedures developed here is not to educate such mechanics on fuel-injection systems, but to expand the knowledge of those who already understand the basic principles of such systems into the area of "closed-loop" fuel-injection systems. Thirdly, given the resource constraints of the contract, it was decided that the effort would be directed to provide diagnostics in areas in which mechanics appear to need the most help. Accordingly, EEA reviewed the results of the mechanics survey and the results of other studies on vehicle malperformances to resolve the requirements of the diagnostic procedure, as described below.

#### **4.2 DIAGNOSTIC PROCEDURES - REQUIREMENTS**

The first step in defining the requirements of the diagnostic procedures was to identify these emission control system malperformances that cause significant increases in emissions. It was reasoned that if a generalized procedure should capture most, if not all, the malperformances causing significant increase in emissions -- defined in this study as causing a vehicle to fail the FTP or I/M emission standards by a margin of 15 percent or greater -- such a procedure would be of greatest benefit to the CARB. Accordingly, the results of a recent study performed by Systems Controls Inc., (SCI) under contract to the CARB was reviewed.

In the SCI study, vehicle emissions were measured on the FTP and the I/M idle test on ten vehicles equipped with three-way catalyst "closed-loop" systems. Each vehicle's emissions were measured with all systems normally operating and also with a number of intentional malperformances on the "closed-loop" system with emissions for each malperformance measured individually. Table 4-1 shows the effects of each disablement type on the five vehicles in the sample equipped with feedback carburetors, while Table 4-2 shows similar data on the five vehicles equipped with electronic fuel-injection systems. For each displacement, the table shows whether the vehicle failed the FTP and I/M test (by a 15 percent margin) with a yes or no. Note that many malperformances made the vehicles (especially fuel-injected vehicles) undriveable.

TABLE 4-1

EMISSIONS FAILURES DUE TO INTENTIONAL MALPERFORMANCE  
(FTP and I/M Test)  
Carburetted Cars

Model Year	1981		1981		1981		1981		1981	
Make/Model	Olds Cutlass		Ford Granada		Ford LTD		Plymouth Reliant		Chevrolet Citation	
Engine	3.8L-V6		2.3L-4		5.8L-V8		2.2L-4		2.5L-4	
Fuel System	FBC		FBC		VVC		FBC		FBC	
<u>Disconnections</u>	<u>FTP</u>	<u>I/M</u>	<u>FTP</u>	<u>I/M</u>	<u>FTP</u>	<u>I/M</u>	<u>FTP</u>	<u>I/M</u>	<u>FTP</u>	<u>I/M</u>
Oxygen Sensor	Yes <sup>1/</sup>	No	No	No	No	No	No	No	Yes <sup>1/</sup>	No
Coolant Sensor	Yes	Yes	Yes <sup>1/</sup>	No	Yes	Yes	Yes	No	Yes	Yes
Throttle Position Sensor	No	No	Yes	Yes	No	No	NA		Yes <sup>1/</sup>	Yes
Manifold Pressure Sensor	No	No	No(?)	Yes	No	No	NA		Yes	Yes
Electronic Control Unit	NT		Yes	Yes	ND		Yes(?)	No		NT
Idle Speed Control	No	No	NA		NT		No	No	No	No
Electronic Spark Control	Yes	Yes	NT		ND		ND		Yes	Yes
Carburetor Solenoid	Yes	Yes	No(?)	No	No	No	Yes	No	Yes	Yes
Ground		NT	Yes	Yes	Yes	Yes		ND	No	No

1/ - NO failure only

NT - Not Tested

NA - Not Applicable

ND - Not Driveable/Would Not Start

TABLE 4-2

EMISSIONS FAILURES DUE TO INTENTIONAL MALPERFORMANCE  
(FTP and I/M Test)  
Fuel-Injected Cars

Model Year	1981		1982		1982		1982		1982	
Make/Model	Lincoln Mark VI		Toyota Supra		Cadillac deVille		BMW 528E		Datsun 280Z	
Engine	5.0L-V8		2.8L-6		4.1L-V8		2.7L-6		2.8L-6	
Fuel System	TBI		EFI		TBI		EFI		EFI	
<u>Disconnections</u>	<u>FTP</u>	<u>I/M</u>	<u>FTP</u>	<u>I/M</u>	<u>FTP</u>	<u>I/M</u>	<u>FTP</u>	<u>I/M</u>	<u>FTP</u>	<u>I/M</u>
Oxygen Sensor	No	No	No	No	No	No	Yes <sup>1/</sup>	Yes	Yes <sup>1/</sup>	Yes
Coolant Temperature Sensor	ND*		ND		Yes <sup>1/</sup>	No	Yes	Yes		ND
Throttle Position Sensor	ND		No	No	No	No	No	No	No	No
Manifold Pressure or Airflow Sensor	Yes	Yes	ND		Yes	Yes		ND		ND
Air Temperature Sensor	Yes	Yes	No	No	Yes	Yes	No	No	No	No
Ground	ND		ND		Yes	Yes		NT		ND
Idle Speed Control	NT		NA		Yes	Yes	No	No	Yes	No

\*Driveable when shorted.

- 1/ - NO failure only  
 NT - Not Tested  
 NA - Not Applicable  
 ND - Not Driveable/Would Not Start

As can be seen from Table 4-1, the carburetted systems are sensitive to malperformances of several components, notably the coolant temperature sensor, the carburetor solenoid, the computer and the ground connection for the computer. In some cases, the oxygen sensor appears to cause increases primarily in NO<sub>x</sub> emissions, while the throttle position sensor occasionally cause increases in emissions. The Chrysler vehicles do not bypass secondary air under any malperformance mode and, hence, no defects can be distinguished in the I/M test. Table 4-2 shows that fuel-injected systems (with the exception of the Cadillac Seville) become undriveable when an intentional and malperformance is introduced or else no increase in emissions is observed. The oxygen sensor causes some emission failures, as does the coolant temperature sensor. Failure of the computer always results in fuel-injected cars becoming unstartable. Note that the new Cadillac fuel-injection system continued to run under all other malperformance models, although with high emissions. This can be attributed to "fail-safe" design where the computer recognizes malperformances and operates under a failure mode. The Cadillac also provides visual warnings on failure with internal diagnostics (available on all GM cars) that can be accessed by the mechanics.

Based on these tables, EEA concluded that the fuel system diagnostic needed to consider:

- The oxygen sensor
- The coolant temperature sensor
- The computer
- The computer ground
- The throttle position sensor
- The manifold pressure sensor or airflow sensor (for fuel-injected vehicles only).

Based on the mechanics survey, EEA concluded that most mechanics understood EGR systems and secondary air systems on older cars but could use some information on more recent changes to these systems, e.g., backpressure

EGR and the inclusion of the switch valve in the secondary air system for "closed-loop" three-way catalysts. Mechanics were less knowledgeable in the operation of the closed-loop system and many were clearly unqualified in electronic fuel injection systems and internal diagnostics. Accordingly, EEA devoted a greater effort in providing generalized diagnostic procedures for such systems than for EGR, secondary air and open-loop fuel systems. Finally, our literature review and the mechanics survey revealed no promising methods currently available for diagnosing malperforming catalysts; EEA, therefore, has attempted to develop tests for catalysts based on the expertise of their lead engineer and their consultant, Mr. Gary Casey.

#### **4.3 GENERALIZED TEST PROCEDURES**

Based on our review of manufacturer recommended test procedures, it was obvious that there were several similarities between the different manufacturers' recommendations. In fact, the procedures for diagnostics on secondary air systems (except for Toyota) and EGR systems who found to be nearly identical between manufacturers. In fuel systems, there were several tests that were common to the common technology groups using feedback carburetors and mechanical fuel-injection systems, although there was less commonality in the recommended diagnostic procedures by the different manufacturers. As stated above, no substantive procedures were available for the diagnosis of catalyst malfunction.

##### **4.3.1 Basic Flowchart**

In our development of the procedures, it was apparent that a preliminary description of system operating would be required since the survey results showed that many mechanics do not understand the operating principles of "closed-loop" systems. A key aspect of these systems is that the computer often controls the secondary air, EGR and fuel systems and a malperformance in the fuel system (especially the closed-loop portion) often causes the computer to shut down EGR and divert secondary air to atmosphere.



Table 4-3 outlines EEA's flowchart for the generalized diagnostic procedures. Note that the system description is listed first. Conversations with manufacturers reveal that a pictorial description of the operation of closed-loop systems is recommended. Although such a description is not included in this report, many manufacturers have provided this as written materials for seminars -- for example, both GM and Bosch provide a pictorial representation of the operating principles of "closed-loop" systems. Such standardized representations are useful in aiding the mechanics understanding of the system. Note that the sequence of diagnostics is specified, since malfunctions of mechanical components in the secondary air system or EGR can cause the fuel system to behave erroneously.

#### **4.3.2 System Specific Diagnostics**

The procedures developed by EEA are widely applicable and require no special tools other than the ones required by BAR for licensed Class A mechanics. The procedures are presented in Tables 4-4 through 4-12 and recommend checks that must be performed in the sequential order of their appearance. The generalized procedures assume that the mechanic is familiar with the conventional (oxidation catalyst) emission control technology and has an understanding of the operating principles of the overall system. In all cases, tests are performed on warmed-up cars.

Diagnostic procedures for the secondary air system are shown in Table 4-4. The procedures are derived from manufacturers recommendations and are relatively simple. Essentially, the procedure consists of ensuring that the air from the air pump goes downstream to the catalyst when the car is warmed-up for dual-bed catalyst systems and to the atmosphere for single-bed catalyst systems. A simple schematic of a typical secondary air system for a dual-bed catalyst vehicle is shown in Figure 4-1. The diagram indicates the major components of such systems and the mode of operation under cold and warmed-up engine conditions.

TABLE 4-3  
BASIC REQUIREMENTS FOR  
DIAGNOSTIC METHOD

System Description/Mechanic Orientation

- Components
- Connections
- Method of operation

Sequence of Diagnostics

- (1) Secondary Air System
- (2) EGR
- (3) Fuel System
  - (a) Performance Test
  - (b) More Specialized Tests
- (4) Catalyst

System Performance Test For Each System

- Methodology
- Test Description
- Tools needed

Test Response And Action For Each Test

- List of possible responses to each system performance test
- Reasons for the response
- Recommendation for repair or alternative action

TABLE 4-4  
SECONDARY AIR SYSTEMS WITH  
AIR PUMP

Ensure air pump is connected and belts are tight. Check for any cracked or disconnected hoses in the air system. Replace as necessary.

Performance Test

- (1) Dual-Bed Catalyst Systems - Start engine. After engine is warmed up, check for air supply to catalyst by removing the hose connecting diverter valve to catalyst.

If Air Supply to Catalyst - System OK  
If no Air Supply to Catalyst - Check for air supply from pump outlet to exhaust manifold.

<u>Test Response</u>	<u>Probable Cause</u>	<u>Action</u>
No Air from Pump	Pump Failure Loose Drive belt Leaks in the hose	Replace Pump Tighten Replace hose or hose fitting
Air supply to exhaust manifold	Vacuum present at switch valve  Switch valve inoperative	Check vacuum hose routings. Check computer.*  Replace valve
Air dumped to air cleaner/atmosphere	Diverter valve inoperative	Check computer* Replace diverter valve
Heat damage to hoses and air pump	Check valve inoperative	Replace check valve
Backfire during deceleration	Diverter valve inoperative	Replace diverter valve

---

\*See "closed-loop" system performance check.

TABLE 4-4 (cont'd)

Performance Test (continued)

(2) Single-Bed Catalyst System - Start engine. After engine is warmed up, check for air supply to air cleaner or atmosphere.

If air supply to catalyst - System not OK  
 If air supply to atmosphere - System OK

<u>Test Response</u>	<u>Probable Cause</u>	<u>Action</u>
Air supply to exhaust manifold or catalyst	Vacuum present at switch valve	Check vacuum hose routings. Check temperature sensor*
No air from pump	Pump failure Loose drive belt Leaks in the hose or hose fittings	Replace pump. Tighten belts. Replace hose or or hose fittings.
Heat damage to hoses and/or air pump	Check valve inoperative	Replace check valve
Backfire during deceleration	Diverter valve inoperative	Replace diverter

PULSE AIR SYSTEM

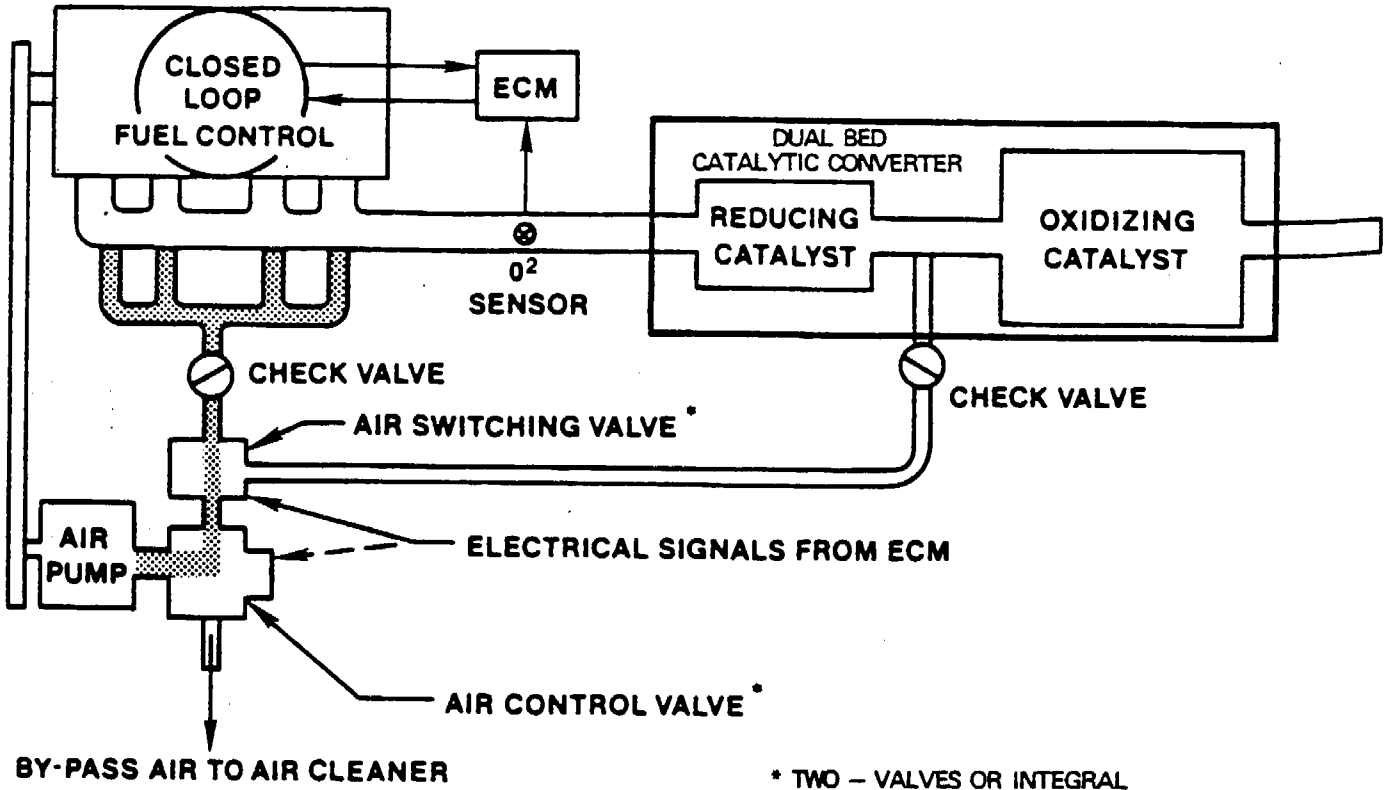
Performance Test - With engine running, check for hissing noise near pulse air valve. Turn off engine. See if rubber hose or air valve exhibits heat damage. Apply a vacuum to the rubber hose connecting pulse air valve to air cleaner. Valve should hold vacuum for 2 seconds. Replace valve if there are signs of heat damage or it does not hold vacuum for 2 seconds.

---

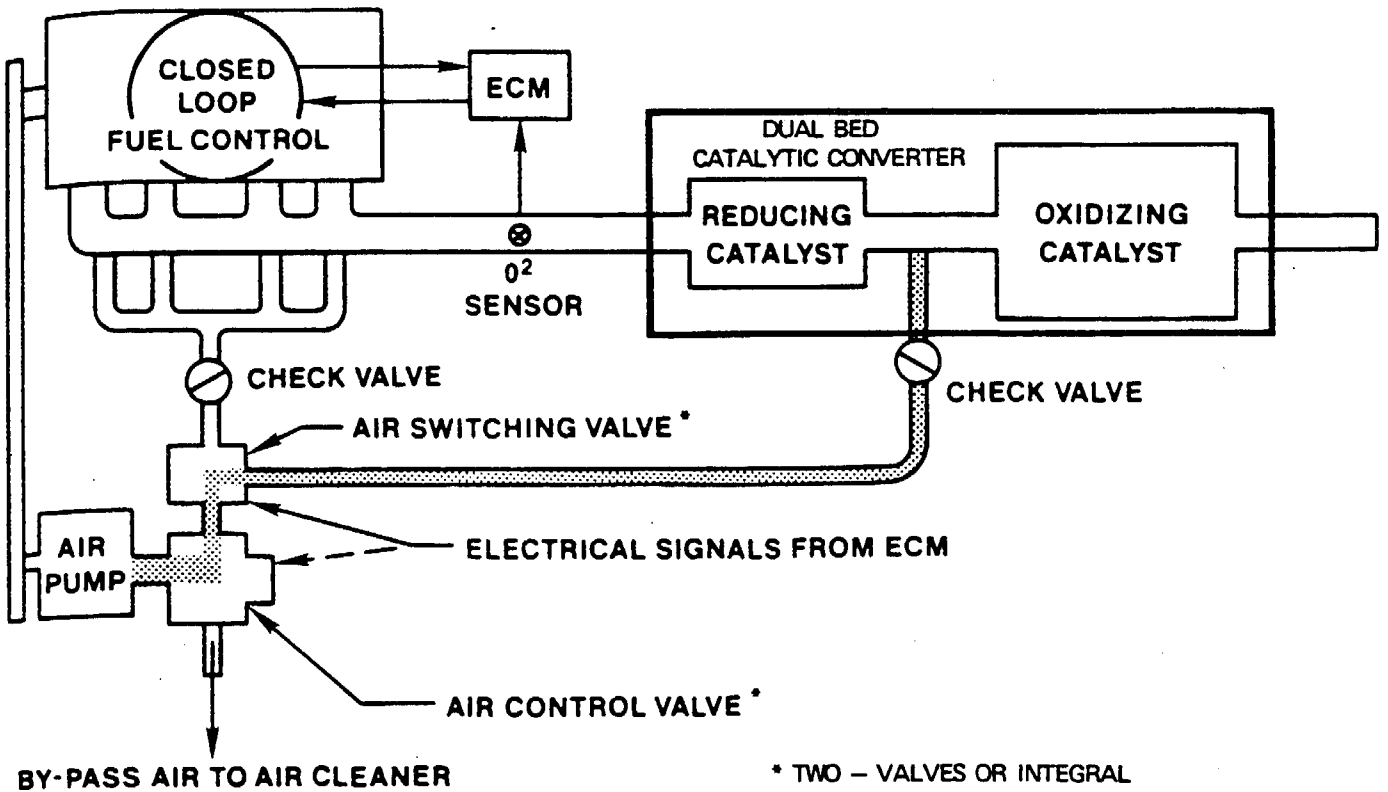
\*See closed-loop system performance check

FIGURE 4-1

SCHMATIC OF SECONDARY AIR SYSTEM  
(Example)



(a) Cold-Start



(b) Engine Warmed-Up

SOURCE: GM

Table 4-5 provides the diagnostic procedures for EGR systems. Care was taken to distinguish between backpressure and ported vacuum systems and an example schematic of each type of system is shown in Figure 4-2. As for secondary air systems, the diagnostics were derived from manufacturer recommendations. The procedure consists of a simple functional check to see if the valve is working and a series of additional checks to trace the fault to the vacuum signal source or to the EGR valve itself.

The major effort in the contract was towards development of standardized procedure for the relatively complex closed-loop fuel system. Based on an ingenious test developed by Chrysler, EEA first developed a closed-loop system performance check that is applicable to all vehicles regardless of whether the system utilizes a feedback carburetor or fuel injection. This is detailed in Table 4-6.

The closed-loop system performance check provides a quick and easy check on the central aspect of closed-loop control -- the control of air-fuel mixture to the catalyst at stoichiometry. If this check is positive, it can be stated that all of the significant components in the closed-loop system are working correctly when the engine is warmed-up. Essentially, the performance check utilizes the human body as a surrogate oxygen sensor and alternately grounding and touching the positive terminal of the battery causes the computer to switch between rich and lean alternately. This results in an audible increase or decrease in engine RPM (from fast idle) if the system is operational. Additional checks with a CO meter can verify if the air-fuel ratio actually oscillates about stoichiometry since CO emissions rise rapidly if the engine is slightly richer than stoichiometric. EEA has performed an engineering test of the closed-loop system check on a variety of cars and the results are tabulated in Table 4-7. As can be seen from the results, the system performance check can be implemented on any closed-loop car and the results can be monitored accurately.

TABLE 4-5  
 DIAGNOSIS OF EGR SYSTEMS  
 (Backpressure and Ported Vacuum System)

System Performance Check: With engine off, place finger under EGR valve and push on diaphragm. EGR valve should move freely from open to close (or replace EGR valve). With transmission in "Park" or "Neutral" and engine running, open throttle to increase engine rpm to 2000. EGR diaphragm should move up (valve open). (Caution: with backpressure EGR, exhaust must be blocked partially to create enough backpressure for EGR to open.) Close throttle on engine and EGR valve should close.

<u>Test Response</u>	<u>Probable Cause</u>	<u>Action</u>
EGR valve does not open	Vacuum hoses improperly connected or leaking	Check and replace hose.
	Defective EGR valve	Connect external vacuum to EGR valve. With engine at fast idle apply vacuum to valve. If valve does not open, replace.
Valve does not open on system check, opens with external vacuum.	Defective thermal vacuum switch (TVS)*	Disconnect TVS and bypass it. If EGR valve opens, replace TVS.
	Defective control system plugged vacuum passage	Check EGR vacuum at carburetor or manifold. Clean Vacuum passages.

---

\*In some cars, the EGR vacuum is controlled by an electrical solenoid that is turned on by the computer. If solenoid is inoperative, replace or else check computer (Table 4-6).

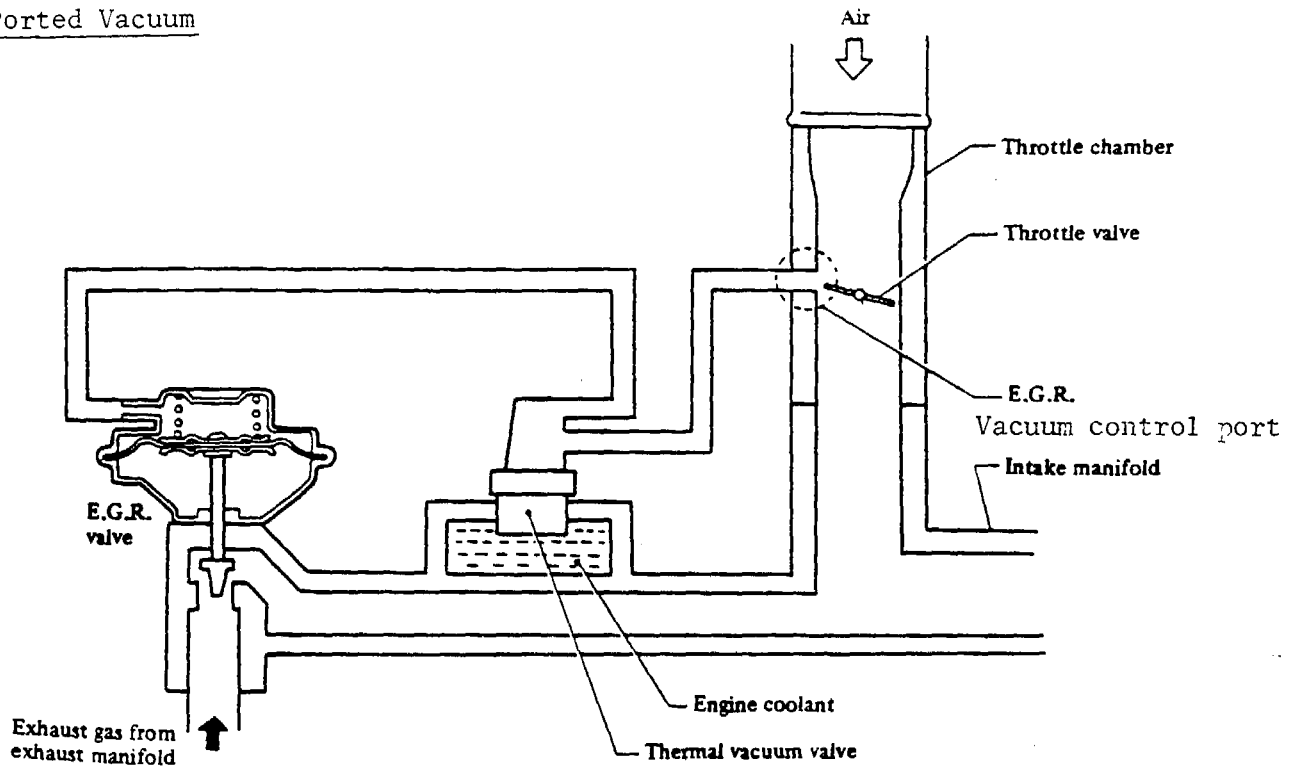
TABLE 4-5 (cont'd)

<u>Test Response</u>	<u>Probable Cause</u>	<u>Action</u>
Valve does not stay open with external vacuum (Ported vacuum system only)	Defective or leaking diaphragm	Apply vacuum and clamp hose. Valve should remain open for at least 30 seconds, or replace.
EGR valve open at idle	Vacuum control defective	Disconnect vacuum hose from valve. If valve closes, check carburetor for sticking throttle. If valve opens, replace EGR valve.
Engine rough at idle EGR valve closed	High EGR leakage with valve closed	Remove EGR valve and inspect to ensure poppet is seated. Clean deposits, if necessary or replace.

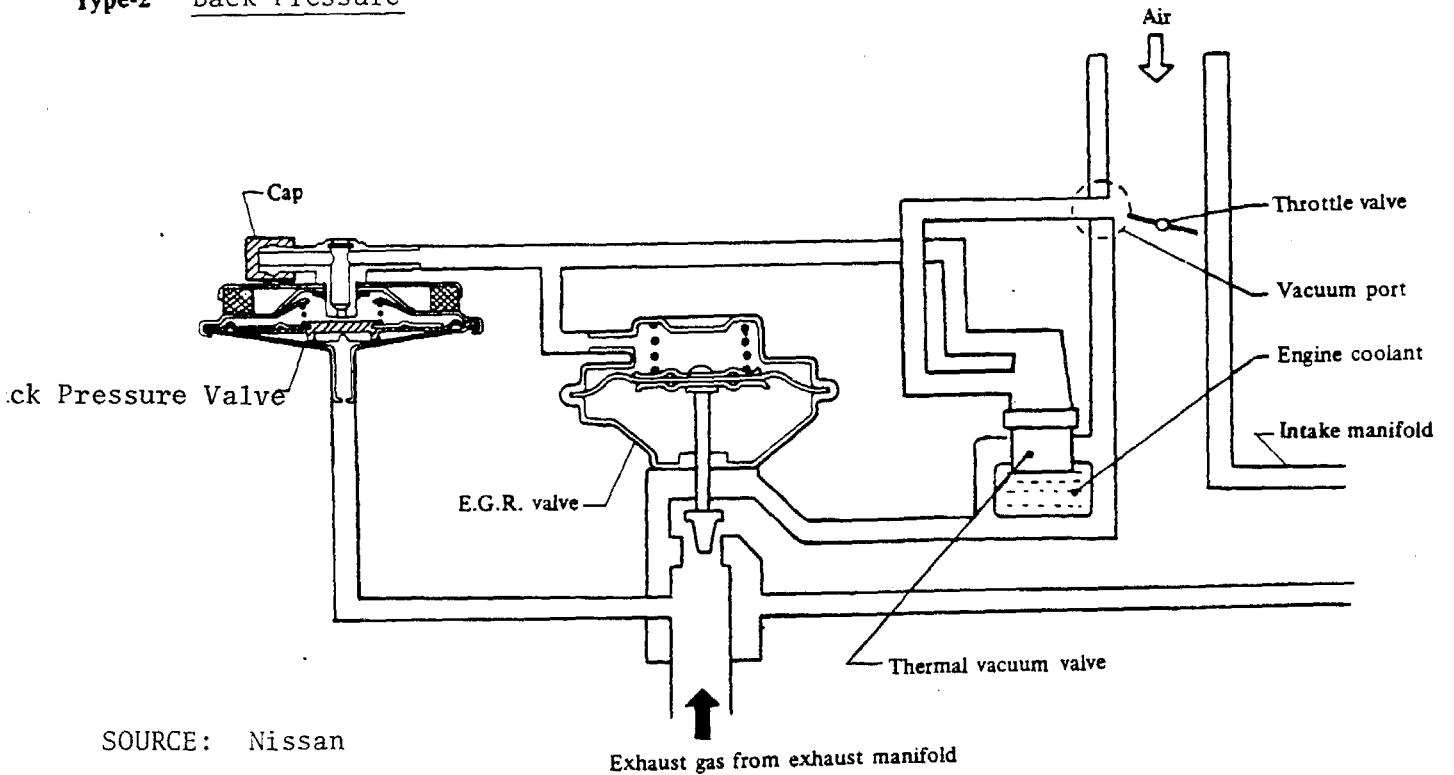


FIGURE 4-2  
SCHEMATIC OF EGR SYSTEMS  
(Example)

**Type-1** Ported Vacuum



**Type-2** Back Pressure



SOURCE: Nissan

TABLE 4-6  
CLOSED-LOOP SYSTEM  
PERFORMANCE CHECK AND OXYGEN SENSOR CHECK  
(Common for all Closed-loop Cars)

1. With engine off, disconnect harness connection at oxygen sensor.
2. Connect voltmeter (use high-inpedance voltmeter) to oxygen sensor. Start car and warm-up at fast idle.
3. Touch oxygen sensor harness lead with one finger. Using the other hand, touch battery positive (+) terminal (engine in fast idle).
4. If system is okay:
  - Engine speed will decrease when touching battery + terminal. Speed decrease will be audible, in excess of 100 rpm.
  - Engine speed will increase if the harness lead is grounded (-). Speed increase will be audible, in excess of 100 rpm.

As engine speed increases and decreases voltmeter connected to oxygen sensor should read 0.5 to 1 volt when engine speed is high, 0 to 0.2 volts when engine speed is low. Disconnect air pump for dual-bed catalyst systems. If system is okay, no voltage on oxygen sensor, check CO reading with the harness lead grounded. If CO reading is high (>2 percent), replace oxygen sensor. If CO reading is low, check for vacuum leaks, adjust idle mixture to specification and repeat test (idle mixture adjustment not applicable for EFI systems).

TABLE 4-7

TEST RESULTS FROM  
SYSTEM PERFORMANCE CHECK

System Test - Oxygen sensor disconnected, engine at idle (fast or normal), oxygen sensor harness connector connected to battery positive terminal via human body.

<u>Fuel System</u>	<u>Vehicle</u>	<u>Base RPM</u>	<u>RPM Drop</u>	<u>Time Delay</u>	<u>Roughness</u>
EFI(Multipoint)	1980 Cadillac*	800	50	5 sec.	None
TBI	1983 Pontiac	1800	300	2 sec.	Slight
FBC	1982 Buick	1500	200	2 sec.	Slight
TBI	1983 Renault	2000	150	3 sec.	None
TBI	1982 Lincoln	1800	300	2 sec.	Slight
MFI	1982 VW	2000	400	2 sec.	High
MFI	1982 Volvo	1800	300	2 sec.	Moderate

\*Test not conducted at fast idle.

Failure of the system to respond to the closed-loop performance check indicates that a defect in the fuel system. At this point, it becomes necessary to make the diagnostic method specific to the following fuel system technologies:

- Feedback carburetor
- Mechanical fuel-injection (Bosch CIS)
- Electronic fuel-injection

Most feedback carburetors are equipped with an electrical solenoid that modulates fuel flow and hence the air fuel ratio. The electrical signal to the solenoid has a duty cycle that controls the actual air-fuel ratio, and this duty cycle can be monitored with a dwell meter. This provides an effective indication if the computer is performing incorrectly or if the fault lies with the carburetor solenoid or other mechanical parts. EEA has surveyed all of the domestic manufacturers (who are the largest users of feedback carburetted systems) and found that the signal to the solenoid and the resulting directional trend in air-fuel ratio are similar among the different manufacturers. Table 4-8 details the diagnostic method for feedback carburetor equipped systems. The sequential checks allow the mechanic to determine if the fault lies in the carburetor, the computer, or the coolant temperature and throttle position sensors. This test is not applicable to some early 1980 Ford cars equipped with a feedback carburetor where the air-fuel ratio was modulated by a stepper motor.

Mechanical fuel injection systems are all of the same type, since they are made by the same manufacturer, Robert Bosch. In principle, these systems resemble the feedback carburetor in that the feedback control modulates the air-fuel ratio set by the existing mechanical system. In the carburetor, the modulation is achieved by an electrical solenoid that closes and opens a fuel flow orifice; in Bosch systems, the fuel-injection pressure is modulated by a "frequency valve." As with the

TABLE 4-8

DIAGNOSTIC METHOD FOR  
FEEDBACK CARBURETORS

1. With engine off, connect dwell meter to carburetor solenoid.
2. Turn engine on. Carburetor solenoid should click audibly. Dwell meter should read a constant value of 18-30<sup>o</sup>.
3. Start car and warmup. Perform closed-loop system performance check. Dwell meter must read low when harness is grounded. high when finger is touching battery.

<u>Test Response</u>	<u>Probable Cause</u>	<u>Action</u>
No dwell meter reading.	Loose connection to solenoid.	Repair.
	Computer inoperative.	Replace computer.
	Disconnected ground.	Check ground lead and tighten.
No audible clicking (dwell okay)	Carburetor solenoid inoperative.	Clean solenoid, or replace.
Low dwell (<30 <sup>o</sup> ) with finger touching battery	Loose connection in oxygen sensor wire.	Check continuity and replace.
	Coolant Temperature sensor failed (open).	Check connections to sensor. Check resistance and replace sensor if open.*
	Computer inoperative.	Replace computer.
	Throttle position sensor (TPS) inoperative.	Check connections to TPS. Measure resistance of TPS with throttle closed and open. Replace TPS if resistance out of specification.
High dwell (>50 <sup>o</sup> ) with oxygen sensor connector grounded.	Coolant Temperature sensor failed (short).	Check connections. Check sensor resistance & replace if shorted.
	Computer inoperative.	Replace computer.

\*Coolant sensor should be below 5000 ohms when car is warmed up.

carburetor, the electrical signal to the frequency valve can be monitored by a dwell meter and hence the method of diagnostic is similar. Table 4-9 presents the diagnostic method for Bosch mechanical fuel-injection systems (K-Jetronic). The diagnostic is even simpler than for carburetors as these systems have no coolant temperature or throttle position sensor that affects their performance. A schematic of the system and its method of operation is provided in Figure 4-3 as an illustration.

Electronic fuel injection systems do not offer the possibility of simple diagnostics as the feedback loop is integrated into the entire system and does not modulate an existing mechanical system. The computer determines the amount of fuel injected into the engine based on a number of engine parameters as well as the output of the oxygen sensor. Hence, the output of the computer cannot be monitored to provide an understanding of whether the closed-loop system is functional. Based on data from intentional malperformance tests, EEA has found that there are relatively few component failures that will allow the engine to run and have high emissions. (Note that if computer is not operational, the car will not start. This report does not concern itself with the diagnosis of such problems.) Table 4-10 shows the functional checks that can help determine if the coolant temperature sensor throttle position sensor or air temperature sensor are the causes of the problem. More importantly, manufacturers have recognized that diagnostics for such systems are difficult and have provided several internal diagnostic aids to help the mechanic. For example, Nissan provides a light mounted on the computer; if the light flashes intermittently, it verifies that the closed-loop is functioning. GM provides comprehensive internal diagnostics that is flashed out on the dashboard light in a code if the mechanic interconnects two specific leads in the car. Since GM offers many electronically fuel-injected cars, EEA believes that it is worthwhile to include the codes and their interpretation in any mechanics' manual. Table 4-11 lists the codes for components whose malperformance can lead to significant increases in emissions. We have verified that these codes are applicable

TABLE 4-9

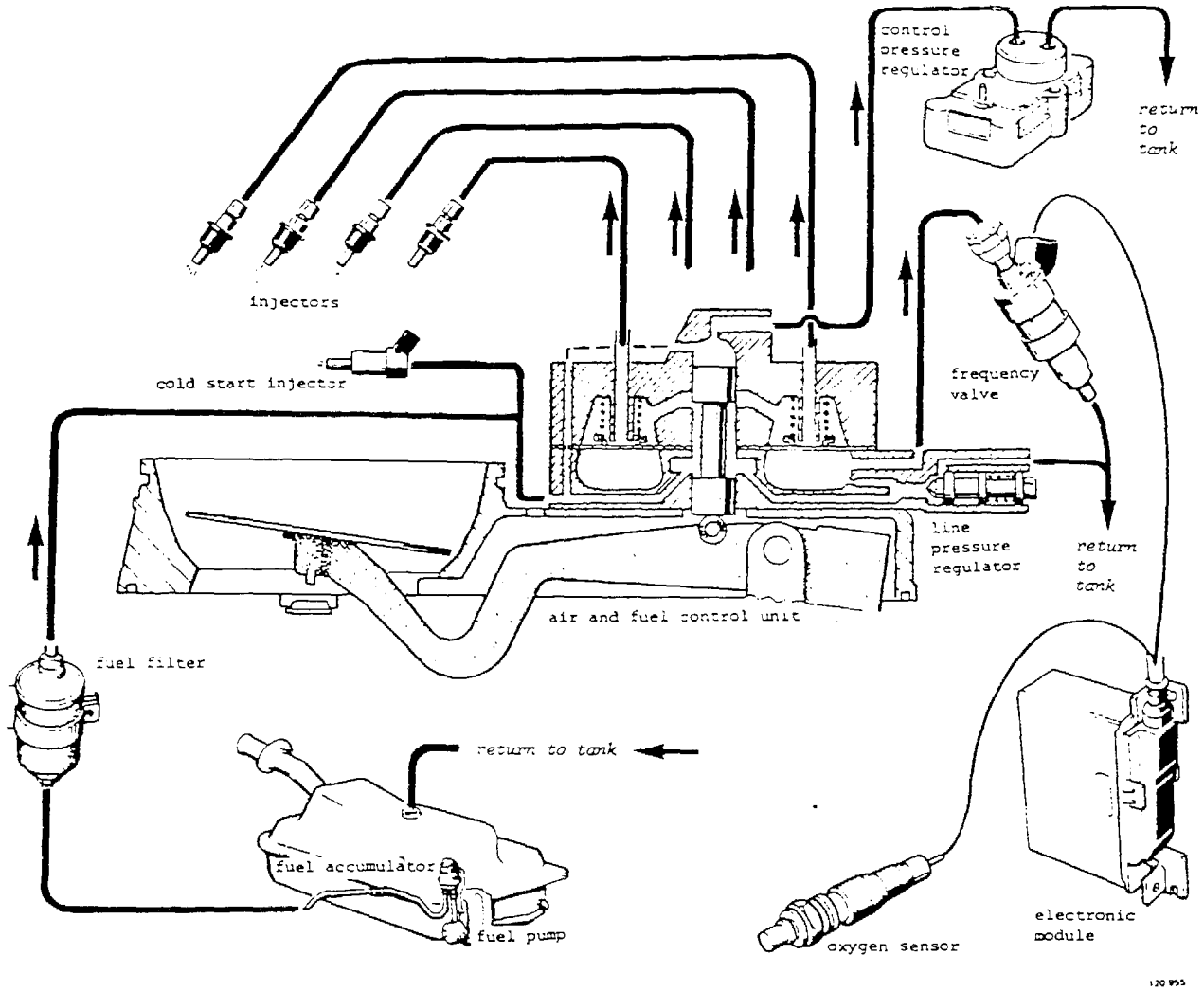
DIAGNOSTIC METHOD FOR  
BOSCH K-JETRONIC FUEL SYSTEM

1. With engine off, connect dwell meter (high-impedance) to frequency valve input or to test socket, if available.
2. Turn ignition on without starting engine. Frequency valve must click audibly. Dwell (on 4-cylinder scale) must be about 60°.
3. Perform closed-loop system performance test. Dwell meter must go from 90° when harness is grounded to less than 50° when finger is touching battery.

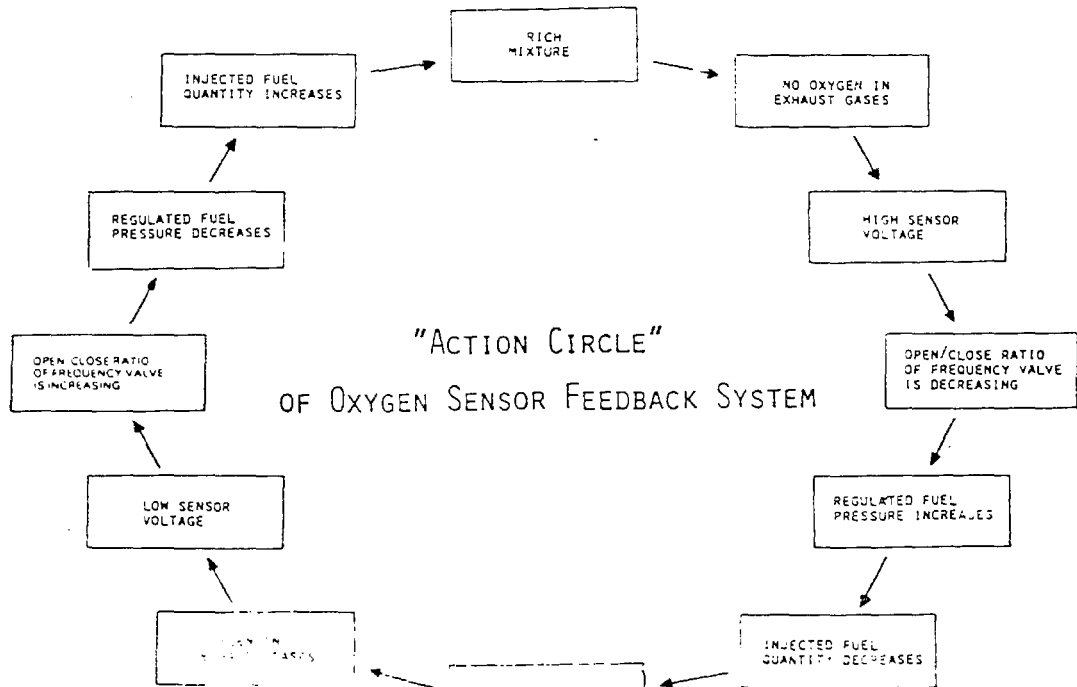
<u>Test Response</u>	<u>Probable Cause</u>	<u>Action</u>
No audible clicking (Dwell meter reads 60°)	Frequency valve inoperative	Replace frequency valve
No dwell meter reading	Frequency valve failed	Check resistance If lower than 3 ohms, replace.
	No connection between computer valve.	Check harness for con- tinuity.
	Bad computer	Replace computer
	Disconnected ground	Check ground lead and tighten.
System performance check fails (no change in speed)	Bad connection in wiring harness for oxygen sensor connection	Check continuity, replace wire or connector.
	Computer inoperative	Replace computer.

FIGURE 4-3

SCHEMATIC OF BOSCH MECHANICAL FUEL-INJECTION SYSTEM



120 953



SOURCE: Volvo



TABLE 4-10  
 DIAGNOSTIC METHOD FOR  
 ELECTRONICALLY FUEL-INJECTED SYSTEMS

These diagnostics are applicable to all electronically fuel-injected vehicles.

1. Disconnect air pump and clamp hose (if applicable). Insert CO probe in tailpipe. Proceed as in system performance test.
2. Ground sensor harness. Engine should speed up from fast idle.

<u>Test Response</u>	<u>Probable Cause</u>	<u>Action</u>
No engine response CO high.	Coolant Temperature Sensor (CTS)	Check if sensor is shorted or open at harness. Replace if necessary.
	Throttle Position Sensor (TPS)	Check movement of sensor. Check if sensor is shorted or open and replace.
	Harness	Check connections to CTS, TPS, and injectors. Repair as necessary.
	Computer	Check by replacing with new unit.
No engine response CO low.	Fuel pressure	Check if fuel pressure regulator is damaged. Check if fuel pressure from pump is at specification.
	Injectors	Check injector spray. Clean or replace as necessary.
	Repeat checks for high CO case.	
Engine responds CO low.	Fuel Pressure	As above.
	Injectors	As above.

Access internal diagnostics, if possible (see Table 4-11 for GM vehicle diagnostic codes).

TABLE 4-11

TROUBLE CODES FOR C-4 ON-BOARD DIAGNOSTICS  
(Closed-Loop Carburetor)

Application	GM 1.6L GM 3.8L AMC 2.5L		
<u>CODE</u>		<u>CIRCUIT</u>	<u>FAULT</u>
13		EGO Sensor	EGO sensor or sensor connection ECM or ECM connections; sticking TPS
14		Shorted coolant sensor	Low coolant/engine overheating Coolant temperature sensor Grounded ECM input/faulty ECM
15		Open coolant sensor	Coolant temperature sensor/sensor connection ECM/ECM connections
23		M/C Solenoid	M/C solenoid or solenoid connections ECM or ECM connections
44; or 44 and 55		EGO Sensor-Lean	EGO sensor or sensor connection ECM or ECM connection Carburetor calibration
45		EGO Sensor-Rich	EGO sensor or sensor connections ECM Carburetor calibration or restricted air cleaner
51		ECM	PROM (faulty or mis-installed)
52/53		ECM	ECM
54		M/C Solenoid	M/C solenoid (if solenoid resistance low) ECM or ECM connections (if resistance high)
55		Power supply/EGO/ECM	Shorted or grounded sensors (TPS, MAP, BARO, Vacuum, Speed) EGO sensor ECM

for all makes and models of GM cars. This internal diagnostic message is an invaluable aid for the more complex electronic fuel injection systems.

Catalyst Systems should be checked only after all other systems are checked and found to be working properly. Since no simple tests were available in literature, an engineering understanding of the principles governing catalyst operation were used to design two alternative methods to diagnose catalysts.

A normally operating catalyst will oxidize HC and CO in an exothermic reaction thus reducing the concentration of HC and CO in the exhaust. Our two suggested methods for diagnosis make use of these properties to check for catalyst malfunctions.

EEA also recommends the normal physical checks for evidence of misfueling and/or physical damage to the catalyst. The diagnostic method is shown in Table 4-12. After completing the physical checks, the two alternative methods can be performed. In the first method, a spark plug is disconnected so that the air-fuel mixture comes out of that cylinder essentially unburnt. If the catalyst is operational, the oxidation of this unburnt mixture will result in a significant temperature increase. EPA has experimented with this test and has found the temperature increase is easily observable (by placing one's hand near the exhaust). However, in some cases, it was found that the temperature rise was so high that there was potential for catalyst damage or an underfloor fire; EEA, therefore, does not recommend the test unequivocally. The second method is derived from the system performance test developed for closed-loop cars. Since the system performance test allows the engine to operate "closed-loop" with the oxygen sensor disconnected, it now becomes possible to remove the oxygen sensor and insert a CO probe through the orifice while the engine still operates closed-loop. The object of the exercise is to be able to monitor the CO concentration upstream and downstream of the

TABLE 4-12  
PRELIMINARY RECOMMENDATIONS FOR  
CATALYST SYSTEM DIAGNOSTICS

1. Inspect filler neck for tampering.
2. Poor engine response, lack of power can indicate plugged catalyst.
3. Remove catalyst. Hold up to light to check for melted substrate or obvious plugging. Tap cannister to check for movement (non-GM cars only).
4. Method 1\* - Attach thermocouple to exhaust pipe at catalyst outlet. Disconnect one spark plug in engine, while engine is running. If catalyst is functioning, it should heat up rapidly and thermocouple output should rise.

Method 2\*\* - (May require two CO meters)

Remove oxygen sensor, and install CO probe through socket in exhaust pipe. Insert second CO probe into tailpipe. Disconnect air pump or clamp hose to cut off air. Perform closed-loop system performance check (see Table 4-6). Tailpipe CO should be much lower than CO sampled through probe at oxygen sensor location under all conditions, if catalyst is functioning.

Note: These preliminary recommendations have been revised in Phase II of this study.

---

\*EEA does not yet recommend this method because of possible catalyst damage.

\*\*Applicable only to "closed-loop" cars

catalyst without installing any special lines in the exhaust (only Volvo provides a pre-catalyst sample line). Disconnection of the air pump is recommended to avoid any erroneous readings due to secondary air dilution. With the engine operating around stoichiometry, the CO concentration should diminish substantially after the catalyst. if the catalyst is operating normally. Note that two CO meters are required to take simultaneous readings of CO concentration ahead of and after the catalyst.

In summary, EEA believes that the tests developed offer simple generalized procedures that can be followed by mechanics to diagnose most of the major malfunctions in closed-loop three-way catalyst systems. We caution the CARB that only limited testing has been performed to validate these procedures, and complete validation must await Phase II of this effort.



## 5. POTENTIAL CARB ACTIONS TO INCREASE DIAGNOSTICS EFFECTIVENESS

The diagnostics methods developed by EEA can be useful to mechanics in diagnosing malfunctions of emission control systems, but the adoption of these methods by mechanics can be aided by a number of potential CARB actions. Based on the results of the survey of mechanics and our own experience in the development of the diagnostics, a few suggestions are provided in this chapter that could enhance the effectiveness of the diagnostics developed under this contract.

Emissions Test - There were a surprisingly large number of mechanics in the survey who did not know the details of the I/M test or gave wrong answers about how it was performed. Another source of confusion was in the standards applicable to each car, especially in the Bay Area and San Diego. As a result, many mechanics had a low opinion of the testing methods and test personnel employed at the I/M test center. EEA is of the opinion that a pamphlet or poster on the test procedure and standards would be very beneficial. Since the CARB is considering the implementation of alternate test procedures in 1984, it may be very important to provide such information to mechanics in the future.

Training - The survey clearly identified that chain shop mechanics had little incentive to receive any new training, while independent garage mechanics' incentives were dependent on the owner. Most closed-loop cars are currently being repaired at dealerships but as they get older, they are likely to be repaired at independent garages or chain stores. Accordingly, the CARB must provide some means to assure that non-dealership mechanics are trained in the operating principles and the diagnostics of such electronically controlled systems. A possible CARB action may involve a compulsory 1-day course for all mechanics at least once a year, so that their knowledge can be periodically updated.

Diagnostic Technology Standardization - Manufacturers produce a diversity of emission control systems, but, as shown in our study, they share common operational principles. EEA's technology forecasts show that manufacturers are increasingly likely to adopt electronic fuel injection systems. Our work identified these systems to be more difficult to diagnose but less prone to an emissions failure (many emission control system failures result in the car becoming undriveable). However, many manufacturers are adopting built-in self-diagnostic systems although the procedure to access these diagnostics is not standard. The CARB, in collaboration with the industry could propose a standard set of diagnostic access codes. Universal adoption of a flashing light if the closed-loop is operational (as in some Nissan cars) would be a major step forward in helping mechanics diagnose such systems.

Information - Mechanics also requested an information source they can turn to for general help in determining technology behavior or component specifications. The manufacturers could provide a "hotline" so that mechanics can gain easy access to such information. For example, the CARB can require all manufacturers and emission test centers to have an information telephone during working hours on weekdays. The Bureau of Automotive Repair (BAR) could, alternatively, provide a central source of information hotline.



APPENDIX A  
SURVEY OF CALIFORNIA  
SMOG MECHANICS



## INTRODUCTION

### Background And Objectives

The California Air Resources Board (CARB) is concerned about the ability of the automotive repair industry to effectively diagnose and repair the sophisticated emission control systems found in many post-1980 automobiles. These vehicles are often equipped with three-way catalytic converters, tamper-proof carburetors, and electronic fuel injection systems; devices which, in the opinion of the CARB, render the mechanic's job of diagnosing and repairing the vehicles difficult.

Due to Federal anti-trust laws which prohibit cooperation among manufacturers regarding emission control designs, increasingly complex mobile source pollution controls, and a biannual mandatory vehicle inspection program beginning in 1984 for most of California's cars and light-duty trucks, the Air Resources Board believes that a survey of current diagnostic and repair practices is needed. Energy and Environmental Analysis, Inc. (EEA), working under contract with the CARB, commissioned J.D. Power & Associates as a sub-contractor to conduct a study detailing mechanics' experiences with the emission control systems.

The purpose of this study is to collect information on the approach employed by mechanics to diagnose and repair

malfunctions in emission control equipment. This has been accomplished through a series of informal interviews with mechanics in three metropolitan areas of the state. This study is not intended, nor is it presented herein as a statistical, quantitative study. Rather, it presents representative information on the approach of a cross section of the state's mechanics to perform emission related work.

Sample And Method

Using guidelines developed by the EEA, J.D. Power & Associates developed the questionnaire used during the course of this study. Following its approval by the CARB, sixty-three interviews were conducted with mechanics in three cities in California. Mechanics in the Los Angeles area were chosen from lists supplied by the CARB, which included stations certified to conduct emissions related work. No such lists were available in the San Diego and San Francisco areas, so mechanics were selected from local telephone directories and were screened for emission control certification status. Sampled stations were divided into three categories: new car dealerships, independent service/repair facilities and chain service facilities in the following manner:

Interviews Conducted

<u>Cities</u>	<u>Type Of Facility</u>	<u>Number Of Interviews</u>
Los Angeles	Dealer	14
	Independent	15
	Chain	6
San Diego	Dealer	5
	Independent	6
	Chain	6



San Francisco	Dealer	4
	Independent	4
	Chain	3

All interviews were conducted with Bureau Of Automotive Repair (BAR) certified class A mechanics. Experience varied among mechanics from those with more than thirty years experience to those certified for less than 1 year. Most mechanics had some experience in the repair of feedback carburetors and electronic fuel systems, however, some did not.

There are two reasons why mechanics without this type of experience were interviewed in this study. First, it was very difficult to find qualified mechanics within the three cities. When stations in the Los Angeles area were contacted, using the CARB listing dated October, 1982, many had completely dropped out of the emission control repair program. This was especially true among the chain service/repair facilities. Second, and more importantly, any attempt to look at a representative sample of mechanics must look at all mechanics who the state certifies as qualified to repair emission systems.

All interviews were conducted during the months of December, 1982, and January, 1983, at the mechanic's place of work during normal working hours. Interviews lasted between fifteen minutes and one hour with the average about one-half hour. The length of the interview varied with the mechanic's loquaciousness, and his or his employer's patience with the time away from normal work. No incentive was given to the mechanics and all interviews were

tape recorded. All mechanics were informed of the purpose of the study and told of its eventual use by the CARB. Participation was, of course, voluntary and while a few mechanics refused to answer some questions or at least asked that the recording equipment be turned off while answering some questions, no mechanic refused to be interviewed after hearing about the purpose or the sponsor of this study.

All interviews were then summarized by the staff of J.D. Power & Associates and this report was compiled from those summaries. All interview summaries are found in the Appendix to this report. The report text follows this section and is divided into several sections. These are:

1. Summary Of Findings
2. Conclusions
3. Mechanic Experience
4. General Approach To Emission Diagnosis And Repair
5. Specific Approach To Emission Diagnosis And Repair
6. Additional Comments

## OVERVIEW

### Dealerships

Compared to mechanics in the other two categories, mechanics at dealerships are more educated and are viewed as more knowledgeable about the makes in which they specialize. If a mechanic at a chain has a problem with a Datsun, for example, he will not recommend that the car be taken to an independent garage. Rather, he will tell his customer to go to a Datsun dealer because "they have the equipment and the knowledge", as one chain mechanic said.

However, the dealership mechanics, while qualified on their own make of car, have very little in the way of specialized equipment or training for other makes of cars. If a Dodge dealer mechanic cannot repair a Datsun 280ZX he will recommend that the customer get his work done at a Datsun dealer.

Dealership mechanics never deal with the customer except in the rare case where a driveability question must be answered. Monetary limits are discussed by a service writer with the customer and he tells the mechanic what the customer does and does not want repaired. The mechanic will test the vehicle using the tailpipe probe to determine the problem with the vehicle.

A mechanic at a dealer has access to all the latest information on his make of car and has no trouble receiving bulletins or

specialized manuals. Their questions can be answered by a factory representative or at special manufacturer sponsored schools. Attendance at these schools is required for dealership mechanics and usually occurs every few months.

These mechanics are the least likely to see tampered vehicles because most of their work is done on new or recently purchased cars still under warranty. The newer cars, some dealer mechanics say, are the ones most difficult to tamper with due to their complex emission systems.

These mechanics, as the official authorized service representatives, are more likely than other mechanics to fix all that is wrong with a car and are more likely to try, if the customer agrees, to repair a vehicle to manufacturer specifications rather than just fix it so that it passes the emissions test. One reason for this is that these mechanics have more complete access to all of the manufacturer's specifications.

Dealership mechanics, in greater percentages than other mechanics, try to repair the more complex emission control systems if they are present on the particular make of car on which they perform repair work. These more complicated systems include the feedback carburetors, fuel injection systems, and the internal diagnostic controls. If a dealer mechanic does not know about these systems the chances are that his make of car does not have them. One BMW mechanic did not know about internal diagnostics because "they aren't on BMW's".



There is no difference between mechanics over how they repair a car except that dealer mechanics have more information than other mechanics. Their method of diagnosis and repair is the same as other mechanics. Those who work on emission problems generally take the same approach and use the same tools in their job.

### Chains

Mechanics at chain stores are at the mercy of the company they work for. The company's policies regarding time limits on how long to work on a car, equipment that should be purchased to repair a car, and training that should be paid for dictate what a mechanic knows and repairs.

Training for these mechanics is sporadic and usually completed before he begins to work at a chain store. Their experience in repairing electronic fuel injection, internal diagnostic systems, and feedback carburetors is limited at best. No chain store mechanic, for example, had any knowledge of pulse air systems and only a third had ever worked on fuel injection systems.

A policy of guaranteeing work and of doing as much work as possible while present at other shops especially limits the types of vehicles that these mechanics will repair, and this in turn, limits the mechanic's ability to learn from hands-on experience about the complex new systems. The reasons why this policy plays a bigger role in limiting a chain mechanic than other mechanics was never discussed by those interviewed.

Similar to their dealer counterparts, chain mechanics never deal with a customer, and they never discuss monetary limits with customers for their work. Like other mechanics, chain mechanics find that manuals are obtainable, and under-the-hood stickers on cars are found most useful. These mechanics are very likely to see tampered vehicles because they are more likely to repair the older and more easily modified cars.

Because their's is high volume business, chain mechanics seldom repair, or attempt to repair other emission problems than the one which failed the original emission test. Their aim is first for the car to pass the test and only second for the car to run well.

Within the limitations of what they do work on, their procedures in diagnosing and repairing a vehicle are no different than other mechanics.

### Independents

Independent mechanics are much like dealership mechanics in the type of work they can do but they are close to chain mechanics in the lack of training opportunities available to them. They too are faced with the twin pressures of guaranteeing their work and doing a high volume of business, but their approach to their job and the types of vehicles they service make them more akin to dealerships rather than chain mechanics.

An independent mechanic usually has the schooling of a chain mechanic: trade school, high school auto shop, or military

experience. Other training is received on his own and usually at his own time and expense. An exception to this is if a mechanic works at a company which has installed expensive equipment like a dynamometer, the owner protects his investment in that equipment by making sure that his mechanic knows how to use it.

The independent mechanic deals directly with the customer. He discusses cost limitations, and if the customer has a complaint about driveability, the mechanic will hear it. Just as with other mechanics, the servicing of a vehicle is limited only by the mechanic's experience and equipment on hand. Whereas no chain mechanic interviewed had worked on pulse air systems, almost half of independent mechanics have. Manuals and service bulletins are available to this type of mechanic and if they have a special problem with a car, these mechanics often mention calling up a dealership service department for the answer.

Independent mechanics, like the chain mechanics, see a high percentage of tampered vehicles and they also often work on vehicles that have been previously repaired by chain stores. They make no attempt to repair a vehicle beyond what is necessary to pass the emissions test unless a customer specifically requests it.

Their approach to the repair of emission problems is no different than other types of mechanics and if an independent mechanic has the experience, he will repair all types of emission systems.

### Los Angeles vs. San Francisco and San Diego Mechanics

Service industry personnel in the South Coast Air Basin are not much different than their counterparts in San Francisco or San Diego. A few differences were noted, however, and these are related to the way the inspection program is run in the Los Angeles area.

In Los Angeles, when a car fails an inspection test, an inspection sheet is given to the owner and the vehicle must be repaired and then retested at the smog inspection site. In the other two cities examined, a vehicle failing an emission test can be repaired and recertified by a qualified mechanic without the inspection sheet or the need for a second test. In Los Angeles, the mechanic will scrutinize the inspection sheet and then, using an infrared exhaust analyzer, begin to retest the car. The mechanic in the other cities will go directly to the retest.

Problems emerge because mechanics in Los Angeles must put their work up for a second test while in San Francisco and San Diego, mechanics can simply certify what they do. Discrepancies between the test center's readings and the mechanic's readings were frequently mentioned by Los Angeles mechanics and are important in a mechanic's determination of how to fix a vehicle. Questions about the quality of the test center's personnel and comments about "alienation" from the CARB are heard from Los Angeles area mechanics but not from others.

Other than this, mechanics in the three cities approach and repair emissions problems in the same way. The type of training and equipment that a mechanic has is determined by the type of facility he works for, not the city in which he works. What a mechanic will repair is a function of his experience, not the city he lives in.



MECHANIC EXPERIENCE

The number of years of experience the mechanics had varied widely. Almost a third of the mechanics have at least 20 years experience while all have worked as mechanics for at least four years. The average number of years mechanics have worked in automotive repair is 16.5.

Number Of Years Working As A Mechanic

Less Than 5 Years	1%
5 - 14 Years	46
15 - 24 Years	36
25 - 34 Years	8
35 Years Or More	<u>9</u>
	<u>100%</u>

All mechanics interviewed were required to have been certified by the California Bureau Of Automotive Repair. This certification allows the mechanic to work on smog related equipment. Several mechanics, according to their responses regarding the date of their BAR certification, had apparently been licensed to do smog control work even before the inception of the BAR in 1972. This probably accounts for the seemingly high average number of years of certification, at 9.7, though the BAR has been in existence little more than 10 years.

Number Of Years BAR Certified

Less Than 5 Years	22%
5 - 9 Years	37
10 - 14 Years	20
15 - 19 Years	10
20 - 24 Years	4
25 Years Or More	<u>7</u>
	<u>100%</u>

Mechanic training varies by the type of service facility. New car dealerships provide the most training for their mechanics with classes every few months sponsored by the manufacturer and paid for by the dealer. For mechanics at dealerships, the incentive to go to these classes is provided by the dealership. They pay for his training and provide him with the time to go. The mechanic who works at a Chevrolet dealership, for example, is given the opportunity and encouragement to go to the General Motors School for Automotive Repair which is usually held every six months. Additionally there are local seminars on Chevrolets that he might also attend. However, new car dealership mechanics also may have to work on and certify vehicles that are not of the same make as sold by their dealership. A Chevrolet dealer might have to repair a Honda that someone traded in when they bought a new Chevrolet. Usually there is no training for mechanics at dealerships in any types of cars other than that which their dealership sells. The Chevrolet mechanic, for example, is unlikely to have had training in the repair of that traded-in Honda. Overall, though, the mechanics at the dealerships have had the most extensive training of all mechanics interviewed, and



their training is updated on a more regular and consistent basis than mechanics at independent facilities and chains.

Independent service/repair facility mechanics report that their formal training consisted of mechanical classes taught at high schools, colleges, the armed forces, or vocational/technical schools, and if they had ever worked at a dealership, manufacturer sponsored schools. All other classes and formal training an independent mechanic might receive comes from night or weekend school. Incentive for attendance at these schools depends on the owner of the independent repair facility. Those mechanics employed at a service center utilizing specialized equipment like a dynamometer are more likely to report that their owners encourage them to go to school, even allowing them to take days off to do so than those mechanics at less well-equipped service facilities. Generally, at independent centers, if an owner is willing to invest in the resources to repair all types of emission control systems, he will make sure that his mechanic is properly trained in the diagnosis and repair of those systems.

Mechanics interviewed at chain repair shops are the least educated of the three groups of mechanics. Like their counterparts, their education is limited to those classes provided in the public sphere. The manufacturer-sponsored seminars and workshops are not for them unless at some point in their career they worked at a new car dealership. While these seminars are open to all, although hard to get into, there is little incentive

for these mechanics to go and learn about the more complicated or newer emission systems. As one mechanic said, "We never work on them, so what's the point of learning about them". Chain facilities are guided by two principles in the repair of vehicles, mechanics report. The first is that their's is high-volume business. One mechanic at a chain said that the owner would not let a mechanic work on a car for the four or five hours needed to repair the fuel injection system. In that time, one could do several tune-ups on older and easier-to-work-on cars. Second, most chains guarantee that their work will pass the inspection test. With that kind of offer, a mechanic at a chain said, "We will only do the work that will pass the test". Overall, mechanics employed at chain facilities have no incentive and in a real sense, no need for further or updated training.

For mechanics from all types of work environments, the best education is not from the schools or the seminars. Rather, it is from the "hands-on" work that they do. One mechanic at an independent garage said that when "we get a car with a system we never saw before, we just play with it to see how it works. That's the best way to learn". However, for mechanics at chains, if they are never given the opportunity to work on the more complex types of systems, they are never allowed this type of education.

All mechanics interviewed have had at least some experience with vehicles in the state inspection program. Some admitted

confusion at the term "I/M" employed throughout the questionnaire but all, as evidenced by answers given during the interview, had done at least some work on vehicles that either were about to or had just completed the inspection test.

Most mechanics, but not all, have experience in the repair of electronic or "feedback type" emission systems. As explained in the sample and method section of the Introduction, some mechanics with no experience in this area were interviewed for the reason that the state certifies them as qualified to repair such equipment whether or not they have the knowledge or experience to actually accomplish such repairs.

According to mechanics interviewed, the California Air Resources Board requires that all certified service centers be equipped with several pieces of test equipment. If any of these are not present at the facility, the station loses its certification. These required pieces of equipment are listed below.

- Exhaust gas analyzer
- Oscilloscope-ignition analyzer
- Ammeter/ohmmeter/voltmeter
- Tachometer
- Vacuum/pressure gauge
- Dwell meter
- Ignition timing light/advance tester unit
- Compression test gauge

Another common piece of test equipment is an auxiliary vacuum source which most stations reported having on hand. Of special interest is a dynamometer. Used in the Hamilton test centers in the South Coast Air Basin to load the rear wheels to measure for

nitrogen oxides (NOx), this expensive test equipment is not required by the state to be in certified smog repair stations. Some independent garages have them but few chains or dealerships do. How mechanics test for the presence of NOx when repairing or certifying a car will be discussed in the Approach section of this report but in terms of having a dynamometer as available equipment, only eight of the interviewed mechanics report one on the premises. Two more mechanics said that their facilities have purchased them but have not yet installed them.

GENERAL APPROACH TO EMISSION DIAGNOSIS  
AND REPAIR

When a vehicle first enters a service shop, the shop mechanic determines what is wrong with the car and how to repair it according to his own system. The steps taken vary by individual mechanics but a few patterns are evident. Los Angeles area service personnel first study the inspection sheet provided by the Vehicle Inspection Program (VIP) at the Hamilton Test Centers. These sheets indicate the type of problem(s) for which the vehicle failed and the emission standards which the vehicle must meet before it can be certified. Then mechanics retest the system using a infrared exhaust analyzer.

Mechanics in San Francisco and San Diego do not receive an inspection sheet from the Hamilton Test Centers. Instead, when a vehicle comes in for service, these mechanics do the same as their Los Angeles counterparts; they retest the vehicle using the infrared exhaust analyzer. Those areas which fail this test are then repaired by the mechanic.

All mechanics approach the repair of these problems in the same way. Rather than using service manuals, troubleshooting charts, or service bulletins, all rely on what their experience has shown to be is the fastest way to find a problem, and this method varies by the type of car being serviced. This "experience is the best teacher" method is used on all cars the mechanic has had

experience with. On new cars, with which a mechanic has had little or no previous experience, the recommended methods according to the troubleshooting charts or the manuals are most frequently used to repair the vehicle. Few mechanics admit to using a hit and miss or trial and error method to diagnose and repair emission problems.

Dealing with the customer is again a practice which varies among the mechanics interviewed but patterns do become evident. Seldom do mechanics at new car dealerships discuss the cars they service with the car owners. Service writers or service advisors usually handle such matters. The only time a dealership mechanic might discuss smog related work with a customer is if the mechanic has a problem with a specific aspect of the car (i.e. its driveability, handling, performance). Mechanics say that these occasions are rare, for most use the inspection sheet and/or the retest by the exhaust gas analyzer. This is all the information that they need to repair emission systems.

Chain store mechanics follow the same procedure as dealership mechanics. Customer contact is handled by a service manager and the mechanic is limited to the inspection sheet and retest. For both of these types of mechanics, the monetary limits of the inspection program are discussed by the service writer or manager and not by the mechanic.

Independent service personnel generally deal directly with the customer. These mechanics will meet with the customer, discuss

the monetary limits allowed and any problems they might encounter during the repair process.

Driveability is not often discussed with customers unless there is a specific reason for doing so. Depending upon the problem, some mechanics will give the car, once repaired, a test drive but this is far from the norm. At some dealerships a quality control person will drive the car before returning it to the customer, but again this practice appears highly unusual.

Mechanics interviewed will service any vehicles for which they have the experience to service with a few limitations. First, company policy may limit the types of vehicles serviced. Chain stores often will not work on complex emission systems such as feedback carburetors and fuel injection because of the perception that much mechanics time will be involved. A station specializing in the repair of certain types of vehicles (one mechanic only services Rolls-Royce and Jaguar) will not even accept for repair any other types. Vehicles they cannot service are referred back to a same make dealer. Second, Federal law requires a 5-year, 50,000 mile warranty on emission systems. Independents and chain shops, when encountering a vehicle that might still be under warranty, will recommend that the vehicle be returned to the dealer for warranty service rather than do it themselves. Third, certain types of vehicles which a mechanic has had trouble with in the past will be sent to the dealer. One mechanic mentioned Cadillacs and Datsun 280ZX's as difficult cars

to repair. Others cited the lack of equipment to service the fuel injection systems found in European imports as their reason for telling the customer to go elsewhere.

Most mechanics interviewed said that it is their station's policy (and also state law) that emission system repair be handled only by the mechanics who are state certified. Most interviewed specialize in tuneup work as well as their emission work.

Service manuals are required by the State of California to be present in all certified repair shops be they dealerships, chains or independents. No mechanic claimed to have trouble obtaining a manual and if they had a car for which they did not have a manual, obtaining the book was usually a simple process of calling the dealership and asking for one. For most mechanics in the survey the information contained in the manuals was adequate. A few would like to see more specific information on the electronics in cars or more detailed step by step information on repair of the emission equipment. If a manual does not have the needed information, mechanics will generally call the service department at a dealership that sells that make of car and speak to another mechanic. A few service personnel have also called the Air Resources Board for information on pollution standards for specific types of cars and for unusual problems like cars imported by an individual without any smog control devices at all.



All mechanics use the stickers or decals under the hood and find them useful. Many admitted to using them more than the service manuals and most mechanics interviewed indicated that the decals supercede any manuals. Problems encountered with these stickers are few. If a sticker is placed on the hood and for some reason the hood has been removed or replaced, then the sticker, of course, is useless. The early stickers with word descriptions were not popular. On late model cars, the stickers include diagrams which mechanics find easier to use. Those decals with vacuum hose diagrams are the easiest to use and most helpful to the mechanic. Some wished for more information on the stickers like spark plug gaps, recommended CO levels, and carburetor information.

Few service people interviewed have worked on a vehicle which they had repaired before, which then failed the smog inspection test. In the cases where this has occurred, a mechanic's procedure is no different the second time than the first.

Dealers, on more than a few occasions, but not often, repair vehicles which have been previously repaired by other facilities. Chain stores and independent garages seldom see these kinds of vehicles, which are usually repaired by a dealership mechanic.

As mentioned at the beginning of this section, all mechanics retest the vehicle using the exhaust gas analyzer. In Los Angeles, mechanics complained of discrepancies in the readings that they obtain and the readings recorded by the Hamilton Test

Centers. This problem was not experienced in San Francisco or San Diego and this difference is explainable by the nature of the three cities' smog programs. When a vehicle fails a smog test in the Los Angeles area it must be repaired by a mechanic and then returned to the test center for a second test. In San Francisco and San Diego, the vehicle, upon failing the initial test, is repaired and certified by the mechanic. There is no retest by the test center. This means that discrepancies between a mechanic's readings and the test center's readings are of little concern in San Francisco and San Diego (some mechanics say that the differences are due to a car's idling for a long time in the test center line) while Los Angeles mechanics have a real problem.

If a car comes to a mechanic with an inspection sheet saying that it failed due to a high level of hydrocarbons but the mechanic, on a retest, finds that the hydrocarbons are below state standards for that type of car, what does he repair? As one mechanic said "As far as I am concerned, there is nothing wrong with the car". When faced with this discrepancy, Los Angeles mechanics usually try to repair those parts of the car which may have caused the original failure and often will communicate with the inspection facility to discuss the discrepancy. These differences between the readings are rare but occur often enough that some mechanics went to great lengths to discuss their attitudes about the testing program. Their comments are detailed in the additional comments section.

The inspection center inspects vehicles for carbon monoxide, hydrocarbons and nitrogen oxides. The test for nitrous oxides is done by a dynamometer, a piece of equipment not required in certified garages. Mechanics having no dynamometer, when faced with a vehicle failing for NOx emissions, generally try one of two approaches to repair that vehicle: they either send it to a service center with a dynamometer or they try to repair it themselves using the equipment they have available. Said one mechanic about the second method, "I feel I can test for NOx and repair it with the equipment I have on hand". Few mechanics viewed the lack of a dynamometer as a major problem.

Discussion of tampering rates was hindered by a lack of definition of the word tampering. Some mechanics felt that any attempt to alter or modify an emission system constituted tampering while others believed that anything wrong with an emission system meant that it had been tampered with. As a consequence of this lack of consensus in the definition of tampering, the percentage of vehicles that mechanics had seen tampered vary widely. One mechanic reported that 99% of the vehicles he sees have been tampered with while another thought that only 1% had been. The average percent of tampering among all mechanics interviewed giving a percentage is 34%.

Rate Of Tampering As Perceived By Mechanics

Less Than 20%	31%
20% - 39%	33
40% - 69%	24
70% - 99%	<u>12</u>
	<u>100%</u>



Chains and independent garages generally do not get much business from facilities that cannot, for one reason or another, repair a vehicle. In most cases, they are the mechanics who send the vehicles to another facility. New car dealerships get much business from other facilities. Mechanics at the dealers, especially those who can service the complex emission systems, are usually the only mechanics with the expertise to adequately repair such systems.

When a customer brings in a vehicle for smog control work, a mechanic, on occasion, might discover that in addition to the part of the vehicle that caused the failure at the inspection center, another part of the emissions system is either inoperative or malfunctioning. For example, a mechanic might discover BB's in an air pump hose which the inspection center did not notice. Most mechanics will not fix this other part; they will report it to the customer and if the customer wants to pay for having it fixed then the mechanic will repair it. However, seldom did a mechanic report that he would go ahead and make the necessary repairs on that second part. The prime reason for this policy is the cost limitation imposed by the state for emission repair. The limit barely covers minimal repairs. Said one mechanic, "We charge \$33.00 an hour for labor. That, plus the cost of a part, does not leave much room for repairing other things that go wrong and still stay within the \$50.00 limit."

As a consequence of this policy and because it is generally what the customer wants, a mechanic will repair a vehicle only to the extent that it will pass the emission test again and be recertified. Except for a few mechanics who specialize in higher priced European imports, a mechanic will typically not repair an emissions system up to manufacturer's specifications. Rather, his aim is to simply get that car recertified.





## SPECIFIC APPROACH TO EMISSION DIAGNOSIS AND REPAIR

This section details the ways in which a mechanic diagnoses and repairs specific problems with a vehicle's emission systems. Unless otherwise specified, all mechanics inspect and repair a system each time that the smog readings indicate a system might not be working properly.

### Catalyst

While there was no consensus among the auto mechanics surveyed over how to inspect and repair catalysts, the vast majority of those surveyed do work on the catalyst. According to the Energy and Environmental Analysis staff, there is no good way to inspect a catalyst. However, only one mechanic agreed with the EEA.

Almost all mechanics inspect the catalyst every time the car comes in for emission work. That inspection for some is a simple check to make sure it is on the car. Others, using the exhaust gas analyzer, take a reading with the catalyst on and take a second reading with the catalyst off or with a new catalyst on. Other ways mentioned in checking the catalyst are driving the vehicle and checking for loss of power, listening to the sound of the exhaust going through the catalyst, or smelling the exhaust. Said one mechanic, "If the system is too rich, the catalyst smells". The most common problems encountered were plugged catalysts and deliberately tampered catalysts. If these problems were found, the catalyst was replaced.

## Percent Of Mechanics Who Always Inspect Catalysts

<u>Work at:</u>	
Dealerships	74%
Chains	53
Independents	68
Total Mechanics	67%

### EGR System

The purpose of the EGR system, most mechanics interviewed say, is to recirculate unburned exhaust back into the intake manifold. A few described its purpose as to prevent the engine from pinging, and one mechanic said it kept the car cool at freeway speeds.

Most surveyed Los Angeles mechanics check the EGR if the inspection sheet from the test center indicates that a problem exists. San Francisco and San Diego mechanics inspect it if the infrared test they do when the car comes in shows that the vehicle's emissions are too high. Inspections are completed by the use of a vacuum gauge or hand pump. This is used to see if the valves are able to open. If the valves are stuck shut and cannot be serviced, the valves are usually replaced. Another way used to inspect the valves is by stepping on the throttle. This, according to mechanics, will also open the valves if they are working properly. Mechanics do not inspect the EGR when the car is cold because as one said "when the engine is cold, a thermal control switch is activated so the EGR does not come on". The hose routings are followed to check for leaks and mechanics say they "always" check the existence and operation of the EGR valves.



Many mechanics are not familiar with problems of EGR valves employing a temperature switch or a vacuum amplifier, which are found on newer cars. Of those who are familiar, common problems with them are bad thermal switches (one mechanic says he sees them mainly on GM cars) which require replacing, cold early morning startups which cause the engine to "stumble", and the greater tendency of these systems to fail because of their having more hoses than the older EGR systems.

Percentage Of Mechanics Who Inspect EGR Systems

<u>Work At</u>	
Dealerships	100%
Chains	100
Independents	100
Total Mechanics	100%

Air Pump

Mechanics say the purpose of the air pump is to pump fresh air into the exhaust manifold. Its operation is checked by mechanics if high emission readings are found either by the inspection test or by a mechanic's own retest. Mechanics check it as a matter of course during emission inspections but some do not. The standard way to check the air pump is to disconnect the hoses, especially the external hose, to see if air is being pumped out. The diverter and the dump valve are also checked during the inspection of the air pump.

Percentage Of Mechanics Who Inspect Air Pumps

<u>Work At</u>	
Dealerships	100%
Chains	87
Independents	100
Total Mechanics	97%

Pulse Air Systems

Experience of mechanics with these systems is very limited. No mechanics at chains said they had any knowledge of these systems while only half of the mechanics at independents and dealerships knew about them either.

Problems with pulse air systems relate more to corrosion through acid - "a lot of little holes" is how one mechanic described it, or, more commonly, their tendency to burn up because of hot exhaust, rather than the one-way valves plugging up. This last problem was seldom seen by any interviewees. A San Diego mechanic called the pulse air systems "junk" and said that they "won't hold the heat and exhaust burns them out".

Percent Of Mechanics With Knowledge Of Pulse Air Systems

<u>Work at:</u>	
Dealerships	59%
Chains	-
Independents	46
Total Mechanics	41%

## Fuel System

There are several ways a mechanic determines if there is trouble with a car's fuel system. Hard starting in cold weather, bad gas mileage, poor driveability, high emissions and stalling all indicate a problem. The problems are diagnosed by first checking to see that all the wires are not frayed, the hoses are not leaking, and the fuel pump is not leaking. One mechanic hooks up a one-gallon gas tank directly to the fuel pump to determine if the problem is in the fuel tank, gas line or fuel pump. If the connections appear good, the mechanic usually studies the electronic equipment in the car. If equipped with an internal diagnostic system, a problem with the computer is evidenced by a light on the dashboard. If not, an ohmmeter reading is taken off the computer to see if it is faulty. If faulty, it is replaced. Sensors are usually checked. Mechanics use the car's internal diagnostic equipment if available. If not, they use the ohmmeter. The oxygen sensor is examined by using an ohmmeter but a few mechanics also say they use a voltmeter for this test.

## Carburetor

The carburetor is examined by mechanics in emissions work if the test readings show a need for it. A low emission tuneup is required by the state for all cars if a waiver, due to cost limitations, is to be issued. The choke and fast idle are always checked when the car is cold. Some mechanics will leave the car overnight to start with a cold engine in the morning, others say

they use freon to cool the carburetor. If a carburetor has a solenoid, its pulsing is checked by a dwell meter. There is a lack of familiarity among interviewed mechanics with the feedback carburetor. Many mechanics do not work on them or even understand them. Mechanics who do work on these systems usually check the solenoid through a dwell meter.

Percent Of Mechanics Who Work On Feedback Carburetors

<u>Work at:</u>	
Dealerships	48%
Chains	20
Independents	44
Total Mechanics	40%

Tamper-proof carburetors caused a division of opinion among mechanics as to whether they are in fact tamper-proof. Many thought that the system is too difficult for all but a qualified mechanic to repair while others felt that anyone with a hammer could work on the carburetors. However, mechanics surveyed were largely united in the complaints about the system. The very qualities that make it tamper-proof also make it difficult for a mechanic to repair or adjust. Said one, "all carburetors need to be adjusted. There are times we have to adjust the tamper-proof carburetors to pass the Hamilton test. This costs the customers an additional \$33 because of all that labor." Another said simply, "They are a big pain for everyone concerned".

## Fuel Injection Systems

About one in three mechanics have had no experience with fuel injection systems, and among those with knowledge of the system, more than half could not explain the differences between electronic and mechanical fuel injection. Said one mechanic, "I don't want to (work on fuel injection) and I don't want to invest the money in the equipment to do it."

To diagnose and repair these systems, most mechanics admitted that they follow the procedures and steps recommended by that vehicle's service manual. To do otherwise would lead to a lot of confusion and delay or as one Los Angeles mechanic said "like working in the dark".

Problems are indicated by mixtures running too rich or a lack of fuel pressure. The first step in repair is to check that all connections are properly attached and that the components are connected. The injectors are inspected for dirt or other contamination, the air flow is measured, and all relays are metered to test for malfunction. Equipment used on fuel injection systems is either a Bosch or Sun Tester and some mechanics also use Kent Moore Analyzers.

The differences between the mechanical and electronic fuel injection is most often explained by mechanics saying that with the latter, fuel flow is controlled electronically through regulators and sensors while mechanical is controlled by fuel or throttle pressure. Overall, while mechanics tended to have some

knowledge of one system, they lacked knowledge of the other type. Very few mechanics ever mentioned the words K and L-jetronic systems unless the interviewer mentioned it first and no one was familiar with both terms.

Percent Of Mechanics Who Work On Fuel Injection Systems

<u>Work at:</u>	
Dealerships	82%
Chains	38
Independents	78
Total Mechanics	71%

Internal Diagnostic Systems

With the exception of dealership mechanics that worked on General Motors or Ford cars and half of the mechanics at independent and chain shops, mentioning the internal diagnostic system to interviewed mechanics was fruitless. Some mechanics have never heard of it, some have heard of it but have never seen it and some have seen it but lacked either the knowledge or the tools to use it. Those few who did use it found it a useful device to help in the diagnosis of a car's problem. Some mechanics use a dwell meter to test it and if the computer is faulty they will just replace it.

Percentage Of Mechanics Who Inspect Internal Diagnostic Systems

<u>Work At:</u>	
Dealerships	48%
Chains	47
Independents	52
Total Mechanics	49%

### Most Difficult Area To Repair

No one area stands out as the most difficult to repair and fourteen different systems were mentioned by respondents as being hard to service. Most commonly mentioned but not by more than six mechanics were electronic fuel injection, feedback carburetors, the on-board diagnostic systems, and GM C-4 systems. One mechanic said he had the most trouble with cars which have their whole emission systems removed.





## ADDITIONAL COMMENTS

### Need For Further Diagnostic Information

There are four areas where mechanics pinpoint a need for further information. The first is in the area of the test itself. Mechanics were asked if they were aware of what was being tested by the Hamilton Test Centers. Most mechanics said they were aware of what was going on but did not elaborate. About ten mechanics did not know at all or gave the wrong answers. For this last group of mechanics who account for one-sixth of the sample, the first and foremost need is an explanation of the purpose of the Air Resources Board testing program and what is and is not being tested at the inspection sites.

The second need mentioned by mechanics is in the area of air pollution standards for vehicles. Each vehicle in the South Coast Air Basin is tested for hydrocarbons, carbon monoxide and nitrous oxides. Vehicles in San Francisco and San Diego are tested for the first two of these items. Except for the inspection sheets provided by the testing centers to Los Angeles mechanics, which list the standards a vehicle is supposed to obtain, the mechanics do not know what levels of pollutants a car should emit. One San Diego mechanic asked that there be an identification tag on all vehicles stating "what emission controls the unit is supposed to have, and what the CO and HC readings should be".

His comment also highlights the third need found in this study: detailed information on what pollution equipment should be on the vehicle, and the specifications for that equipment. This information is usually provided in the manuals but some felt that more detail was needed.

The fourth need was mentioned by only a few mechanics. One in San Francisco said it best - "I would like to see a closer ARB office than Sacramento, where we can get information when needed, like smog books, information on American cars, for example. We have to wait too long now instead of just running up and getting what we need." An L.A. mechanic said, "I feel alienated from the ARB now. We need a phone number for general questions".

These four needs all have dealt with more information for the mechanic on the rules he must operate under and the equipment he must fix. One of the purposes of this study was to determine if there was a need for a standard set of diagnostic procedures to use when servicing a car. When asked "what type of diagnostic procedures (information) would you like to see?", only one mechanic mentioned a need for a standardized set of diagnostic steps to follow in the repair of emission systems. Another mechanic in San Francisco said he would like to see a standard set of tools to use on all types of cars because "we don't have the space or the money to have all the specialized equipment to test each car", but he made no mention of a standard diagnostic procedure. When asked specifically if there was a need for such

a thing, one Los Angeles mechanic said, "No, because all the cars are so different".

### The Hamilton Test

In the Los Angeles area, because cars once repaired by mechanics were retested at the Hamilton test centers, feelings were strong about the way the Hamilton center conducts vehicle inspections. These comments were not mentioned in San Francisco or San Diego because in those areas, the mechanic does the recertifying himself -- there is no retest.

The comments of the Los Angeles mechanics centered around two areas. First, the quality of the personnel at the centers and second, the perception that there is cheating at the centers.

The first area is a sore spot to the majority of Los Angeles mechanics. For one reason or another, discrepancies exist between Los Angeles mechanics' test readings and those obtained by the Hamilton center. The usual procedure is to repair what the test center said is wrong and if a mechanic has any trouble he will call the test center for clarification. A standard reply from the test center is "the problem is with our (the mechanic's) machine". Some mechanics not satisfied with this answer and knowing that their machines are tested by the state every two

months have gone to other mechanics and using their equipment, got the same readings as he got on his first test. One mechanic described an experience he had with one car when following up on a discrepancy. He called the state inspector to check his equipment, and the equipment was checked and verified to be accurate. The car he was repairing was within the legal limits on his newly tested machine. The car still failed on the Hamilton equipment which was also inspected and certified as accurate. The problem, as the Los Angeles mechanics see it, is that the people at the Hamilton Center do not have a smog license and are therefore unqualified to be testing the cars.

One mechanic told of applying for a job at Hamilton and being rejected because he was over-qualified. Other mechanics told of inspecting the car's emission system and seeing hoses unhooked, converters disabled, BBs in EGR valves, pumps missing, yet none of these were recorded on the inspection sheet at Hamilton. Each, however, is a reason for failing a car regardless of the readings.

The second problem seen by a few mechanics is the fairness of the test. While none claimed actual knowledge, a couple of mechanics, citing customer complaints, said that the Hamilton people, "by flicking a few dials" would deliberately flunk a car the first time to collect the \$7 retest fee. These two complaints lead to a solution that mechanics would like to see implemented - more qualified, competent people at the test

centers. This they feel would lead to better results and would give the mechanic more information to do his repairs.

Also, under the current program, there is a limit of \$50 that a customer may spend for repairs after failing a test. The majority of mechanics feel that to do the work that is required, this waiver limit should be raised. One mechanic mentioned a \$125 limit, another felt that "any car that pollutes should be fixed, regardless of the cost".



APPENDIX B  
QUESTIONNAIRE





I. EXPERIENCE

1. Number of years working as a mechanic -- BAR certification?
2. What type of training have you had? How long ago was it? In what other ways do you learn about emission systems?
3. Experienced in repair of electronic or "feedback type" emission control system?

Experience in repairing vehicles failing I/M test?

Specialty?

4. Available equipment:

BAR required equipment (1-8)?

Auxiliary vacuum source?

Dynamometer?

Other specialized tools?

II. APPROACH

1. What do you do when a car comes in for smog control service?

Do you test the car or do you use a hit and miss system? Do you use a troubleshooting chart? Do you have troubleshooting charts for all models you may encounter? Do you use manuals or service bulletins in performing the service?

2. Do you deal with the customer? If yes, do you discuss monetary limits for repair problems or optimum driveability? If not, who does?

---

---

3. Any vehicles you will not or cannot service and why?

---

---



4. When cars are brought in for smog control work, can they be assigned to anyone or is there a specialist assigned to the work?
- 

5. Do you have manuals for various types of cars to help you diagnose problems? Do you have enough information on specific models? If not, what do you do when you don't have a needed manual?
- 
- 

6. Do you use the stickers/decals under the hood? Do they have enough information? Is there any other information they should provide?
- 
- 

7. How many times have you worked on a vehicle you had previously repaired which had failed the test? Is your procedure different the second time than the first? How many times have you worked on a vehicle repaired by someone else which had failed the test? Do you correct only the problem that failed the test? Do you ever communicate with the inspection facility because of any discrepancy? What do you do if a vehicle fails the part of the test that you don't have equipment necessary to test (e.g. dynamometer or other specialized equipment).
- 
- 
- 

8. What is the percentage of vehicles that have had their emission control systems tampered with?
-

9. Do you get a lot of business from facilities, (e.g. gas stations) that cannot, for some reason, repair the vehicles?

---

10. When working on a vehicles' smog control system, do you fix it only to the extent that it will pass the test? If so, is this only through the urging of a customer?

---

---

### III. Specifics

1. Do you inspect catalysts? If so, how? What is your experience with them?

---

---

2. What is the purpose of the EGR system? Do you inspect the EGR system? If so, how? (Do you inspect when car is idling or cold?) Do you follow the hose routing? What do you do if the valve is stuck shut? Do you always check the existence and operation of EGR valves? If not, under what circumstances? Are you familiar with problems of EGR systems employing a temperature switch or vacuum amplifier? Please detail your experience with these designs.

---

---

3. What is the purpose of the air pump? Do you always check the existence and operation of the air pump? If not, under what circumstances?

What is your approach to checking the operation of the air pump? Do you disconnect hoses? Do you check the operation of the diverter and dump valve?

Have you worked with pulse air systems (also known as aspirated or reed valve system)? What is your experience with them? Do the one-way valves ever plug up?

---

---

4. Under what circumstances do you decide there is a problem with the fuel system? What, in general, is your approach to diagnosing the problems of electronic fuel control systems? (Following his answer, check to see if he has covered all of the following)

- Are all wires and connections checked?
  - Are wires followed to see if they are broken or frayed?
  - Is the computer checked for all connections?
  - If all connections appear good, what is the next course of action?
    - Check the power supply to see if current is being delivered?
    - Replace the computer?
    - Check the sensors?
  - How do you check the operation of the oxygen (O ) sensor?
  - Do you check to see if the O sensor is putting out a signal? What instrument do you use (a regular volt meter does not work for this test)?
- 
- 

5. Do you check the carburetor? Do you also check the choke and fast idle? If so, how? What components do you check on a feedback carburetor? Do you check to see if the solenoid is pulsing? Are the tamper-proof carburetors really tamper-proof?

---

---

6. Do you check the fuel injection system? If so, how? What is the most common problem? Can you explain differences in the operation of mechanical (with feedback control) versus electronic fuel injection systems?

---

---

7. Are you familiar with internal diagnostics systems? If yes, how do you check to see if it is working?

---

---

8. Which area among the ones you do check, is the most difficult to repair?

---

---

IV. Additional Comments

1. What type of diagnostic procedures (information) would you like to see?

---

---

2. What else could ARB do to help you in the repair of vehicles failing the inspection tests? Do you have any comments about the ARB inspection system? Do you know what is being tested?

---

---

---

---





PHASE II





TABLE OF CONTENTS

	<u>Page</u>
1. INTRODUCTION .....	1-1
2. METHOD OF VALIDATION .....	2-1
2.1 Overview .....	2-1
2.2 Test Plan .....	2-2
2.3 Vehicles/Malperformances Tested .....	2-4
3. DOCUMENTATION OF DATA FROM VALIDATION TESTING .....	3-1
3.1 Overview .....	3-1
3.2 Organization of Validation Data .....	3-3
3.3 Discussion of Results .....	3-4
4. MECHANICS COMMENTS ON THE DIAGNOSTIC PROCEDURE .....	4-1
5. REVISED DIAGNOSTIC PROCEDURES .....	5-1
5.1 Overview of Revisions .....	5-1
5.2 Diagnostic Procedures .....	5-4
6. CATALYST DIAGNOSTICS .....	6-1
6.1 Overview .....	6-1
6.2 Results of Testing .....	6-2
6.3 Conclusions .....	6-6
APPENDIX A: FORM USED BY MECHANICS FOR REPORT DATA .....	A-1
APPENDIX B: LIST OF ABBREVIATIONS .....	B-1



LIST OF TABLES

		<u>Page</u>
2-1	Mix of Cars/Malperformances Used in Validation .....	2-6
2-2	Vehicles Tested by Emission Control Category .....	2-7
3-1	Mechanic Identification of Systems .....	3-9
3-2	Diagnosis of EGR and Secondary Air in CARB/3CL Systems .....	3-12
3-3	Closed-Loop System Check for CARB/3CL Systems .....	3-15
3-4	Defects Introduced and Identified in CARB/3CL Systems .....	3-18
3-5	Diagnosis of EGR and Secondary Air in CARB/3CL/OXD Systems .....	3-21
3-6	Closed-Loop System Check for CARB/3CL/OXD Systems .....	3-26
3-7	Defects Introduced and Identified in CARB/3CL/OXD Systems .....	3-31
3-8	Diagnosis of EGR and Secondary Air in TBI Systems .....	3-37
3-9	Closed-Loop System Check for TBI Systems .....	3-41
3-10	Defects Introduced and Identified in TBI Systems .....	3-45
3-11	Closed-Loop System Check for MFI/3CL Systems .....	3-52
3-12	Defects Introduced and Identified in MFI/3CL Systems .....	3-54
3-13	Diagnosis of EGR and Secondary Air in EFI/3CL Systems .....	3-56
3-14	Closed-Loop System Check for EFI/3CL Systems .....	3-58
3-15	Defects Introduced and Identified in EFI/3CL Systems .....	3-60
5-1	Summary of Problems Encountered .....	5-2
5-2	Secondary Air Systems with Air Pump .....	5-5
5-3	Diagnosis of EGR Systems (Backpressure and Ported Vacuum System) .....	5-7
5-4	Closed-Loop System Performance and Oxygen Sensor Check .....	5-9

LIST OF TABLES (cont'd)

	<u>Page</u>
5-5 Diagnostic Method for Feedback Carburetors .....	5-10
5-6 Diagnostic Method for Basch K-Jetronic Fuel System .....	5-12
5-7 Diagnostic Method for Electronically Fuel-Injected Systems .....	5-13
6-1 Catalyst Diagnostics .....	6-3

## 1. INTRODUCTION

The California Air Resources Board has been concerned about the ability of mechanics to repair defects in emission control systems for post-1979 cars that utilize electronically controlled "closed-loop" three-way catalyst systems. Unlike cars that utilize the "open-loop" emission controls (i.e., pre-1979 cars), the cars featuring "closed-loop" systems can have much more complex failures, and the failure modes can differ depending on the control strategy employed by each individual manufacturer. EEA, under the first phase of this contract effort, developed and recommended a set of standardized diagnostic procedures that could be used to detect major emission control system malfunctions on a wide variety of vehicle makes and models. Under the second phase of this contract, these procedures were validated and modified, as necessary, by testing a large number of vehicles in which the emission controls were intentionally disabled. This report describes the validation carried out, and notes the areas where the recommended diagnostics are inapplicable or have some shortcomings. In addition, the report describes the development of a diagnostic test for catalysts that are inoperative.

The diagnostic procedures developed under Phase I of this study were derived from engineering concepts that would be applicable to all closed-loop systems as well as from a review of manufacturer recommendations for diagnosis of malfunctioning emission control systems. It was recognized at the outset that no general procedure could be used to diagnose every single make and model of vehicle featuring closed-loop control; however, the diagnostic procedure was intended to be applicable to a broad array of commonly used vehicles and be capable of diagnosing those malfunctions that cause a significant increase in emissions. A methodology of validation was developed to enable field mechanics to test the recommended procedures on a wide variety of cars and the methodology is described in Section 2 of this report.

The results of the validation are described in Section 3. Fifty-two cars with intentional disablements were tested by mechanics using the recommended diagnostic procedure and they performed checks of the secondary air, EGR and closed-loop systems. The results are presented in a series of tables that provide a detailed documentation of the applicability of the recommended procedure on the cars tested. In general, the results showed that the diagnostic procedure (with minor changes) can be used on most cars with two notable exceptions --carburetted Toyotas and Hondas.

Section 4 provides some insight into the mechanics view of the usefulness of the diagnostic procedure. This section was written by the mechanics who conducted the validation and points out areas of concern where the mechanics felt that the recommended procedures needed additional support. The mechanics also provided comment on the validity of the diagnostic method.

As a result of the data collected in Phase II, some modest changes and additions were made to the diagnostic procedure. The revised diagnostic procedures are presented in Section 5.

Section 6 details the development of catalyst diagnostic procedures. Unlike procedures for the secondary air, EGR and fuel system, no established procedures exist for catalyst systems. Two possible methods were identified in Phase I of this study, and these methods along with a third more recently developed method were tested on 12 vehicles. The test employed to validate the procedure is described in Section 4. The results obtained using the different test options and their advantages and disadvantages are described in this section.

Appendix A contains the form used by mechanics to report data on each car. Appendix B lists the abbreviations used in this report.

## 2. METHOD OF VALIDATION

### 2.1 OVERVIEW

Under Phase I of this contract effort, EEA developed generalized diagnostic procedures for emission control system malfunctions in three-way catalyst equipped cars. The diagnostic procedures are designed to accommodate a wide variety of makes and models, and are relatively simple to use. When the contract was first initiated, there was concern that the procedures developed would be difficult to understand, especially for a field mechanic with no advanced training. Therefore, the initial plan required that 10 cars which had intentional disablements be tested by 10 mechanics with a relatively broad spectrum of experience levels. The validation would, therefore, have tested the ability of field mechanics to understand and utilize the diagnostic procedure over a small sample of cars. At the end of Phase I, it became obvious that the procedures were relatively simple to understand, and the focus of the validation shifted to testing the applicability of the diagnostic procedures to a wide variety of cars.

Accordingly, the revised test plan called for utilizing only two mechanics (to provide a cross-check) but testing 60 vehicles representing a wide variety of emission control system designs. All cars tested did have closed-loop emission control systems, but differed considerably in their secondary air, EGR and fuel systems. Although some tests were recommended for the catalyst system, catalyst testing was performed separately from the validation study and is described in Section 6 of this report. All tests involved rented vehicles and were, therefore, tests on relatively new cars. Tests were conducted in the Washington, D.C. area and the two mechanics participating in this study were recruited for their above average skills and training -- both mechanics have had

some college and one taught small engine repair at a technical school. The mechanics were chosen so that they could provide insights on how best to improve the diagnostic procedure, and were, therefore, not necessarily representative of the average mechanic in their understanding of the procedure. Since the procedures are straightforward, EEA anticipates no difficulty for any certified mechanic to understand the recommended procedures.

## 2.2 TEST PLAN

The validation included a training seminar conducted by the lead technical project manager, Mr. Duleep and the technical project consultant Mr. Casey, prior to the initiation of vehicle testing. It was found that both mechanics participating in the study -- Mr. Tom Berlin and Mr. Tim Bell -- had only a vague idea of the principles of operation of closed-loop systems. A portion of the training program was, therefore, devoted to explaining the general principles of closed-loop systems and their various distinguishing features. A second area where a lack of understanding was found was in the differences between single-bed and dual-bed catalyts. The differences between the two types of catalyts were explained along with the requirements for secondary air with each type of catalyts. Four cars -- carburetted, throttle-body fuel injected, mechanically fuel injected and multi-point electronic fuel-injected -- were rented for the purposes of training and Mr. Casey and Mr. Duleep demonstrated the entire procedure on each of the four cars. The training period of about four hours was the only training provided for this validation study.

During the validation, EEA had planned to evaluate the procedures over 60 cars. However, as described later in this report, the high rental costs and the high level of technical intervention required by the lead technical project staff resulted in the validation being conducted with only 52 cars. Although ideally, all 52 cars would be different makes



and models, some cars that were procured had inoperative or defective emission controls in an "as received" condition. Since the validation procedure did not allow for replacement of parts, these vehicles could not be repaired although the mechanics were able to identify the problems (in most cases) with the vehicles in question. In order to provide mechanics with more experience on such cars, correctly performing vehicles of the same type were procured and the usual method of validation, as described below, performed.

The validation procedure was as follows: each car to be tested was procured from a car rental company (as a result, the cars were mostly relatively new vehicles). The car was ferried to Mr. Berlin, who served as the control mechanic. He inspected the car and performed the entire diagnostic procedure by selectively disabling components in the fuel system, EGR and secondary air systems. The effect of each disablement on HC/CO emissions, RPM and any internal diagnostic lights (if applicable) was noted along with a comment on the correctness of the diagnostics developed by EEA. He then introduced one or more malperformances in the emission control system as determined by the overall project requirements. The car with the intentional malperformance(s) was sent to the second mechanic, Mr. Bell, who used the recommended procedures to locate the malperformance, and noted the vehicle behavior (RPM/HC/CO) during the various tests conducted. Once he completed diagnosis, he verified its correctness by questioning Mr. Berlin. He then introduced one or more malperformances -- after restoring the original one -- and then returned the car to Mr. Berlin. Mr. Berlin then repeated the diagnostic procedure to identify the malperformances introduced by Mr. Bell, and then returned the car to "as received" condition prior to its return to the renting location. This formed the test plan followed for the validation.

### 2.3 VEHICLES/MALPERFORMANCES TESTED

In order to provide a good representation of the different types of emission control systems used in the fleet, as well as a wide spectrum of manufacturers, the test plan originally called for selecting 60 cars sampled as follows by type of emission control technology:

- Carburetted, single-bed catalyst - 10 cars
- Carburetted, dual-bed catalyst - 15 cars
- Throttle-body fuel injected, single/dual-bed catalyst - 15 cars
- Mechanically fuel-injected - 10 cars
- Electronic, multi-point fuel injected - 10 cars

Under Phase I of the contract, the analysis identified the following component failures as having potentially significant impact on emissions:

- Oxygen sensor (OXS)
- Coolant temperature sensor (CTS)
- Throttle position sensor (TPS)
- Electronic Control unit, or computer
- Primary air/fuel ratio controller
  - mixture control solenoid for carburetors (MCS)
  - frequency valves for mechanically fuel injected systems
  - vacuum or air flow sensor for electronic fuel-injection systems
- Air temperature sensor (in a few vehicles)
- EGR vacuum control
- Secondary air diverter valves

Although the original intent was to test a large fraction of the sixty vehicles with more than one of the above components disabled, it was found that most vehicles would not run (or run so poorly that it was not driveable) with several disablements. In the interest of safety, most vehicles were tested with usually one, or at most, two disablements.

The type of disablements tested by emission control technology type is detailed in Table 2-1.

As stated in Section 2.1, the original goal of testing 60 cars was not met as a result of several difficulties and project resource constraints.

Due to the import restrictions in effect, it was difficult to obtain late model Japanese cars for daily rental, as well as European cars which are the only vehicles to use mechanical fuel injection. Additionally, some vehicles were incorrectly identified in terms of their model year by the renting companies, and it was found after renting the vehicle that the emission control system was not of the "closed-loop" type. Finally, the recommended diagnostics were found not to work on some vehicles, requiring a high level of intervention by the project technical staff. Project resource constraints dictated that only 52 cars could be rented, and the sample size was reduced for mechanically fuel-injected cars and carburetted single-bed catalyst cars. These categories were selected because it was discovered that: 1) mechanically fuel-injected cars of different makes were essentially identical insofar as their emission control systems and little was to be gained from testing 10 vehicles rather than 6, and 2) carburetted single-bed catalyst vehicles were mostly of Japanese origin and hence very difficult to obtain at reasonable rental cost. The final list of cars sampled is shown in Table 2-2, grouped by type of emission control system.

Data reporting by the mechanics on this project was standardized by the use of a form that also served to prompt the mechanic on the diagnostic sequence; the form is shown in Appendix A of this report.

TABLE 2-1

## MIX OF CARS/MALPERFORMANCES USED IN VALIDATION

<u>Type</u>	<u>Sample Size</u>	<u>Sensors</u>				<u>Computer</u>	<u>EGR</u>	<u>Secondary Air</u>	<u>Mixture Control Solenoid</u>
		<u>Ox.</u>	<u>Coolant Temp.</u>	<u>Throttle Position</u>	<u>Airflow/ Manifold Vac.</u>				
Closed-Loop Carburetor Single-Bed Catalyst	8	X	X	X	-	X	X	X	X
Closed-Loop Carburetor Dual-Bed Catalyst	16	X	X	X	-	X	X	X	X
Throttle-Body Fuel Injection*	14	X	X	X	X	N/A	X	X	N/A
Mechanical Fuel Injection	6	X	N/A	-	-	X	N/A	N/A	X
Electronic Port Fuel Injection*	8	X	X	X	X	N/A	X	N/A	N/A

\*Some malperformances caused vehicle to be undriveable. In such cases, other alternatives were used.

TABLE 2-2  
VEHICLES TESTED BY EMISSION CONTROL CATEGORY

<u>Carburetor with Single Bed Catalyst</u>	<u>Carburetor with Dual Bed Catalyst</u>	<u>Throttle-Body Fuel Injection</u>	<u>Mechanical Fuel Injection</u>	<u>Electronic Port Fuel Injection</u>
83 Isuzu I-Mark	83 Dodge Aries	83 Renault Alliance	83 VW Rabbit	83 Nissan Maxima
82 Buick Regal	84 Plymouth Reliant	83 Cadillac DeVille	84 VW Rabbit	83 Toyota Starlet
84 Honda Civic	83 Buick Century	83 Chevrolet Celebrity	83 BMW 320	83 Nissan Maxima
82 AMC Concord	84 Ford Tempo	83 Renault Alliance	81 Saab Turbo	83 Volvo 244 DL
84 Mitsubishi Tredia	81 Chevrolet Malibu	84 Ford T-Bird	83 Volvo Turbo 245	84 Toyota Camry
84 Chrysler New Yorker	82 Plymouth Horizon	83 Chevy Citation	83 Peugeot 505	84 BMW 318
84 Dodge Colt	84 Toyota Corolla	84 Lincoln Town Car		83 Toyota Celica
84 Nissan Sentra	82 Pontiac J-2000	84 Oldsmobile Firenza		83 Volvo 244 DL
	84 Oldsmobile Cutlass Supreme	83 Mercury Grand Marquis		
	83 Toyota Tercel	84 Ford Crown Victoria		
	83 Dodge Omni	84 Pontiac 6000		
	83 Chevy Monte Carlo	84 Buick Skylark		
	83 Toyota Corolla	84 Chrysler E-Class		
	83 Pontiac Grand Prix	82 Pontiac Firebird		
	83 Chevy Camaro			
	84 Toyota SR-5			



### 3. DOCUMENTATION OF DATA FROM VALIDATION TESTING

#### 3.1 OVERVIEW

A large body of test data was assembled during the course of the validation testing, and this section summarizes and documents these data on the behavior of different makes and models of cars when subjected to the diagnostic procedures recommended in Phase I of this effort. Data was collected during each segment of the validation testing starting with the receipt of the car by the control mechanic, Mr. Berlin (Tom). He would then perform the entire diagnostic sequence, starting with secondary air system and the EGR system. Checks of these systems are functional in nature - e.g., checking for cracked hoses, or checking the EGR valve pintle movement. The next check is on the closed-loop system, which involves checking RPM, HC and CO readings during the diagnostic procedure. Following this, components such as the throttle position sensor or the coolant temperature sensor would be selectively disabled (open or short), and the effect of the intentional disablements on idle RPM and HC/CO emissions noted. Mr. Berlin would also note any special system characteristics and introduce an intentional disablement/defect prior to sending the car over to Mr. Bell (Tim). Mr. Bell would then check the different systems until he discovered the disablement, in the manner specified by the diagnostic procedure. This description of the vehicle responses to the diagnostics would indicate vehicle behavior under the disabled condition, and, therefore, differ in some aspects from the results noted by Mr. Berlin. Mr. Bell also noted any special problems that he encountered during the diagnosis of this defect. After correcting this defect, Mr. Bell introduced another defect prior to his returning the car to Mr. Berlin. Mr. Berlin would then diagnose this defect, and only note any special problems encountered during the diagnosis but not the measurements that he had originally documented during the initial checkout.

Accordingly, a large quantity of data was collected and organization of this data into a comprehensible format was a challenge. The data also reflected a number of real world problems of mechanic forgetfulness and resultant incomplete records on some cars. Most of these problems were encountered in the early phases of the validation, and EEA was able to correct these problems by about the 10th car. Other problems also occurred, the most significant being one where a particular car did not respond to any test recommended in the diagnostic procedure. When this happened, it was impossible for the mechanics to introduce defects as it was obvious that the diagnostics were not helpful. In such cases, considerable intervention by the project technical director, Mr. Duleep, and the consultant, Mr. Casey, was required. In each cases where the car did not respond to diagnostics, EEA staff examined the car and referred to available manuals, or consulted with relevant manufacturers to obtain the details of how the closed-loop operates, as well as specific information on the effect of disabling components such as the coolant temperature sensor and/or throttle position sensor. In some cases, rental time constraints did not allow enough time for enquiries to be completed before returning the car; a similar model was rented again so that it could be retested in the light of additional information collected.

Less significant problems included incorrect recognition of vehicle model year by rental organizations, which led to different emission control system representation than that intended. Although we were (in most cases) able to return such cars with minimal cost penalties, two cars rented had to be included in the program. Finally, four vehicles rented were faulty in an 'as received' condition. In such cases, it was impossible to introduce additional defects and mechanics were left to only diagnose the cause of the 'as received' defect.

It must be noted that one of the reasons for the validation was to uncover makes and models of vehicles for which the diagnostic procedures, developed in Phase I of this project, did not prove useful.



Several examples of such vehicles were found and investigated; the results of such investigations were used to improve the diagnostics.

### 3.2 ORGANIZATION OF VALIDATION DATA

Although it was not originally planned, data on mechanics' recognition of systems by type was collected and tabulated. The results are shown in Table 3-1, and they indicate that mechanics, for the most part, recognized systems correctly although their nomenclature was different from those used by automotive engineers. However, in three cases, mechanics appeared to confuse single-bed catalysts with double-bed catalysts. When questioned, it appeared that the source of confusion was their difficulty in tracking the location of the secondary air outlet due to tight packaging on the vehicles in question.

Results of the detailed diagnostic procedure were voluminous, and were therefore broken out by emission control system categories listed.

- CARB/3CL/(Air)
- CAR/3CL/OXD/(Air)
- TBI/3CL and TBI/3CL/OXD/(Air)
- MFI/3CL
- EFI/3CL/(Air)

where (Air) refers to secondary air of either the pulse-type or pump-type (all other abbreviations including those used in the tables are detailed in Appendix B). For each emission control system category, the data is presented in three tables.

The first table details the functional checks performed on the EGR and secondary air systems in terms of Yes/No answers, with any additional comments listed. Since all vehicles were checked by the second mechanic (Tim Bell) with an intentional disablement which could (in many cases) affect the EGR and secondary air system, the vehicle's intentional malperformance is also listed alongside the second mechanic's results.

The second table in the series presents the results of the 'closed-loop' system check which is central to the recommended diagnostic procedure. The results are presented for the readings of RPM (at fast idle), hydrocarbons (HC) and carbon monoxide (CO) for each step of the test sequence during the closed-loop check. In some cases, Tom Berlin, the control mechanic, was not able to obtain a signal to his tachometer as his tachometer requires a connection to the ignition coil; the coil was not accessible on several vehicles. He reported the results in terms of audible speed increases or decreases from the basic fast idle.

The third table provides a listing of the defects introduced and identified by each mechanic, as well as data from other functional or measured checks performed (e.g., RPM/HC/CO readings when the coolant temperature sensor was disabled). Each check was accompanied by numerous comments, and EEA has listed those comments concisely to the extent that these comments are relevant to the diagnostic procedure.

As a result, there are three tables for each of the five emission control system categories, with the exception of the MFI/3CL systems, which have only two tables as none of these utilize secondary air or EGR, making the first of the series of these tables unnecessary. Table 3-2 to 3-15 document the results of the entire validation procedure in detail.

### 3.3 DISCUSSION OF RESULTS

The main purpose of conducting the validation was to uncover problems encountered in real-life with the diagnostic procedures. Rather than discuss each of the vehicles tested and their response to the diagnostic - essentially reproducing the information in the tables - this section discusses only those vehicles above in which we encountered problems.

In the CARB/3CL/(Air) category, the following vehicles displayed peculiarities noted below.

- ISUZU I-MARK - One of the first cars tested and records are incomplete. However, both the diverter valve and EGR valve were difficult to locate and check. The EGR responds to back pressure-type checks, which is included in recommended diagnostics.
- HONDA CIVIC - This car was the only car with an open-loop catalyst system and hence no closed-loop checks are possible. However, EGR and pulse-air systems responded to diagnostics.
- MITSUBISHI TREDIA - This car did not respond to any of the closed-loop checks, even in gear or under a loaded mode condition. Because Mitsubishi vehicles have been introduced only recently, information on their system strategy was not readily available and no further checks could be conducted.
- BUICK REGAL - EGR is turned on only when car is placed in gear.
- CHRYSLER NEW YORKER - The TPS harness is cast in a one-piece molding with several conditions and is difficult to remove our check. In addition, the radiator electric fan turns on at times and causes the engine to slow down, which may lead to wrong conclusions if it happens during closed-loop check.
- NISSAN SENTRA - During the closed-loop check, HC/CO emissions surged upwards when oxygen sensor harness was grounded, but automatically returned to low levels after 5 seconds. We believe that the computer recognizes the oxygen sensor disconnect and reverts to the 'open-loop' mode after a few seconds.

In CARB/3CL/OXD/(Air) systems (Tables 3-5 to 3-7), one of the first vehicles rented was a Dodge Aries, whose closed-loop did not respond to any of the recommended diagnostics. We suspected a bad computer on the vehicle and, therefore, rented an identical Plymouth Reliant soon afterwards. This car also refused to respond to any of the tests, and since the chance of renting two vehicles with faulty computers were small, we contacted Chrysler for their manuals. On the next set of Chrysler vehicles - Dodge Omni and a Plymouth Horizon - the reason for the lack of response was found. A microswitch is incorporated into the throttle that turns off the closed-loop at idle. Although the recommended diagnostics are at fast idle, mechanics would jam a tool between the throttle lever and idle stop to run the engine at fast idle, which prevented the microswitch from turning the closed-loop on. Once this was discovered, there were no further problems with these cars.

Another series of cars of the CARB/3CL/OXD/(Air) type did not respond to the diagnostics were Toyotas. We tested three Toyotas - SR-5, Corolla and Tercel - and these vehicles utilize unique closed-loop system which controls air fuel ratio by modulating an air-bleed system. The air bleed system is turned on by two vacuum switches and the system is in closed-loop mode only at part throttle (intermediate vacuum) but not at idle/low load or wide-open throttle/high load conditions. Fortunately, EEA was aware of those difficulties prior to obtaining the cars and had acquired manuals for these vehicles. Mechanics were able to test the closed-loop system with the manuals, but the system was not diagnosable using the recommended diagnostics. As a result, we did not attempt to introduce and identify malperformances in the closed-loop systems for these cars.

Most of the other cars in the CARB/3CL/OXD/(Air) category are GM cars, which responded very well to all tests. As with the Buick Regal, many of the 1984 GM cars require that the vehicle be put in gear before the EGR is activated. The Ford Tempo in this category was (similarly) easy to diagnose.

In vehicles equipped with throttle-body injection systems (Tables 3-8 to 3-10), the major discovery was with 1984 Ford vehicles - the Thunderbird and Lincoln. In those vehicles, there is a internal diagnostic system that retains its memory of defects. Even after a defect is repaired, the system does not return to proper working order unless the memory is reset. Thus, Ford vehicles would respond to this diagnostic checks, but after repairs, it was necessary to reset the memory. We discovered that the easiest method was to disconnect and reconnect the battery; this has an unfortunate side effect of erasing the clock and radio memories, but the alternative would be to use the manuals to locate the procedure for resetting the memory.

Other system peculiarities in (throttle-body injected systems include:

- RENAULT ALLIANCE - The closed-loop is turned on only when the intake air temperature exceeds 60°F for several minutes. Mechanics were confused on a cold day, when intake air temperatures were low and the closed-loop did not work.
- FORD LTD - The closed-loop and EGR turn on when the vehicle is placed in gear.
- GM VEHICLES - Internal diagnostics provided by the dashboard light which flashed a code often provided incorrect or vague diagnostics and was not of much help in many situations.

In addition, mechanics complained that vacuum leaks or defective manifold pressure sensors were not covered by the diagnostics. Mechanics were instructed to introduce intentional malperformances in the manifold pressure sensors in four cases, and although they were initially unable to diagnose the system, EEA supplied additional information that enabled them to diagnose such systems properly. A second area of concern was in the throttle position sensor connection. This often involved multiple connection that controlled idle speed, wide-open throttle enrichment, etc., and mechanics were not sure of what to check without a circuit diagram.

The mechanically fuel injected systems (Tables 3-11 and 3-12) were found to be the easiest to diagnose. However, EEA cautions that one of the mechanics, Mr. Berlin, is very experienced in the repair of such systems and, thus, an average mechanic's ability to diagnose these defects may be overstated. However, EEA found that all cars utilizing such systems have essentially identical emission control components. The system is also relatively simple, and the number of components required to be checked was small. Mechanics added one extra component for inclusion in the diagnostic procedure - the thermo-tine switch which provides cold start enrichment.

In the final category of electronic multipoint fuel injection, the diagnostic procedure was found to be appropriate up to the point of conducting

checks on components. Because of the complex wiring harness, it was difficult to ensure that checks of the components such as the TPS or CTS were accurate without wiring diagrams. For example, in the Toyota Starlet as in the Nissan Maxima, the CTS and Air Temperature sensors were difficult to locate and test, because of a multiplicity of wires from each connection, and several sensors that appear to be similar in shape and function. The only problem areas not covered by the diagnostics are the airflow sensor/manifold pressure sensor; mechanics pointed at the necessity of including such items in the checks recommended.

Lastly, it must be noted that in many cases, HC and CO readings are of such low levels that common shop instruments cannot record them accurately. For example, instrument drift and zero error are often larger than the measured emissions. This reflects the fact that cars tested are relatively new with fresh catalysts and also the fact that new cars are extremely clean at idle. Accordingly, it is believed that idle emission checks alone are not a good indicator of system malperformances, but are useful in conjunction with the other recommended diagnostics.

TABLE 3-1  
MECHANIC IDENTIFICATION OF SYSTEMS

Year	Make	Model	Emissions Category			Date Tested
			TOM	TIM	Actual	
83	Nissan	Maxima	EFI/3CL	EFI/3CL	EFI/3CL	11/02/83
83	Dodge	Aries	CARB/3CL/OXD	*	CARB/3CL/OXD	11/08/83
84	Plymouth	Reliant	CARB/3CL	*	CARB/3CL/OXD	11/09/83
83	Buick	Century	TBI/3CL/OXD	*	CARB/3CL/OXD	11/11/83
84	Ford	Tempo	CARB/3CL/OXD	*	CARB/3CL/OXD	11/15/83
82	Pontiac	J-2000	CARB/3CL/OXD	(Carb)	CARB/3CL/OXD	11/17/83
83	Renault	Alliance	TBI/3CL	TBI/3CL/OXD	TBI/3CL	11/23/83
84	Toyota	Corolla	CARB/3CL/OXD	CARB/3CL/OXD	CARB/3CL/OXD	12/01/83
83	Cadillac	DeVille	TBI/3CL/OXD	TBI/3CL/OXD	TBI/3CL/OXD	12/12/83
81	Chevrolet	Malibu	CARB/3CL/OXD	*	CARB/3CL/OXD	12/13/83
83	Isuzu	I-Mark	CARB/3CL	CARB/3CL	CARB/3CL	12/14/83
83	Chevy	Celebrity	EFI/3CL	EFI/3CL	TBI/3CL	12/19/83
83	Toyota	Tercel	CARB/3CL	CARB/3CL/OXD	CARB/3CL/OXD	12/20/83
84	Oldsmobile	Cutlass	CARB/3CL/OXD	CARB/3CL/OXD	CARB/3CL/OXD	12/21/83
83	Renault	Alliance	TBI/3CL	TBI/3CL	TBI/3CL	1/03/84
84	Ford	T-Bird	TBI/3CL/OXD	TBI/3CL/OXD	TBI/3CL/OXD	1/04/84
83	Volvo	244	EFI/3CL	EFI/3CL	EFI/3CL	1/09/84
83	Toyota	Starlet	EFI/3CL	EFI/3CL	EFI/3CL	1/10/84
83	V.W.	Rabbit	MFI/3CL	MFI/3CL	MFI/3CL	1/11/84
82	Plymouth	Horizon	CARB/3CL/OXD	CARB/3CL/OXD	CARB/3CL/OXD	1/12/84

\*Incomplete information.

\*\*Mechanics sometimes labelled TBI as EFI but correctly recognized system.

TABLE 3-1  
MECHANIC IDENTIFICATION OF SYSTEMS  
(Continued)

<u>Year</u>	<u>Make</u>	<u>Model</u>	<u>Emissions Category</u>			<u>Date Tested</u>
			<u>TOM</u>	<u>TIM</u>	<u>Actual</u>	
82	Buick	Regal	CARB/3CL/OXD	CARB/3CL/OXD	CARB/3CL/OXD	1/16/84
83	Dodge	Omni	CARB/3CL/OXD	CARB/3CL/OXD	CARB/3CL/OXD	1/17/84
83	Chevy	Monte Carlo	CARB/3CL/OXD	CARB/3CL/OXD	CARB/3CL/OXD	1/18/84
83	Chevy	Camaro	CARB/3CL/OXD	CARB/3CL/OXD	CARB/3CL/OXD	1/23/84
83	Nissan	Maxima	EFI/3CL	EFI/3CL	EFI/3CL	1/24/84
84	Toyota	Corolla	CARB/3CL/OXD	CARB/3CL/OXD	CARB/3CL/OXD	1/25/84
83	Chevy	Citation	TBI/3CL	EFI/3CL**	TBI/3CL	1/30/84
84	Honda	Civic	CARB/3WY	CARB/3WY	CARB/3WY	1/31/84
84	V.W.	Rabbit	MFI/3CL	MFI/3CL	MFI/3CL	2/01/84
82	AMC	Concord	CARB/3CL/OXD	CARB/3CL/OXD	CARB/3CL	2/07/84
84	Mitsubishi	Tredia	CARB/3CL/OXD	CARB/3CL	CARB/3CL	2/08/84
84	Ford	Crown Victoria	TBI/3CL/OXD	EFI/3CL/OXD**	TBI/3CL/OXD	2/13/84
84	Lincoln	Town Car	TBI/3CL/OXD	EFI/3CL/OXD**	TBI/3CL/OXD	2/14/84
84	Oldsmobile	Firenza	TBI/3CL	EFI/3CL**	TBI/3CL	2/15/84
84	Chrysler	E-Class	TBI/3CL/OXD	EFI/3CL**	TBI/3CL/OXD	2/21/84
84	Chrysler	New Yorker	CARB/3CL/OXD	*	CARB/3CL	2/22/84
83	Pontiac	Grand Prix	CARB/3CL/OXD	CARB/3CL/OXD	CARB/3CL/OXD	2/28/84
83	Mercury	Grand Marquis	TBI/3CL/OXD	EFI/3CL/OXD**	TBI/3CL/OXD	2/29/84
84	Toyota	SR-5	CARB/3CL/OXD	CARB/3CL/OXD	CARB/3CL/OXD	3/05/84

\*Incomplete information.

\*\*Mechanics sometimes labelled TBI as EFI but correctly recognized system.



TABLE 3-1  
MECHANIC IDENTIFICATION OF SYSTEMS  
(Continued)

<u>Year</u>	<u>Make</u>	<u>Model</u>	<u>Emissions Category</u>			<u>Date Tested</u>
			<u>TOM</u>	<u>TIM</u>	<u>Actual</u>	
84	Buick	Skylark	TBI/3CL	TBI/3CL	TBI/3CL	3/07/84
84	Pontiac	6000	EFI/3CL**	TBI/3CL	TBI/3CL	3/14/84
84	Toyota	Camry	EFI/3CL	EFI/3CL	EFI/3CL	3/15/84
83	BMW	320i	MFI/3CL	MFI/3CL	MFI/3CL	3/15/84
84	Dodge	Colt	CARB/3CL/OXD	CARB/3CL	CARB/3CL	3/19/84
84	BMW	318	MFI/3CL	EFI/3CL	EFI/3CL	3/20/84
83	Peugeot	505	MFI/3CL	MFI/3CL	MFI/3CL	3/20/84
81	Saab	Turbo	MFI/3CL	MFI/3CL	MFI/3CL	3/21/84
83	Toyota	Celica	EFI/3CL	EFI/3CL	EFI/3CL	3/28/84
82	Pontiac	Firebird	TBI/3CL/OXD	EFI/3CL/OXD**	TBI/3CL/OXD	3/29/84
84	Nissan	Sentra	CARB/3CL	CARB/3CL	CARB/3CL	4/04/84
83	Volvo	244	EFI/3CL	MFI/3CL	EFI/3CL	4/05/84
83	Volvo	Turbo 245	MFI/3CL	MFI/3CL	MFI/3CL	4/06/84

\*Incomplete information.

\*\*Mechanics sometimes labelled TBI as EFI but correctly recognized system.

TABLE 3-2

## DIAGNOSIS OF EGR AND SECONDARY AIR IN CARB/3CL SYSTEMS

<u>Year/Make/Model</u>	<u>Mechanic</u>	<u>Diverter Valve</u>	<u>Check Valve</u>	<u>EGR Valve Working?</u>	<u>EGR at Idle?</u>	<u>EGR at Part Throttle</u>	<u>Cold Temp Vacuum Cutoff?</u>	<u>Comments</u>
<u>1983 Isuzu I Mark (PMP)</u>								
	Tom	See comment	-	None	-	-	NT	Diverter valve not accessible (under carb).
Defect: Vac. leak at brake booster	Tim	See comment 1	Works (see comment 2)	Yes	Closed	Yes	Yes (see comment 3)	(1) Dumps to air cleaner when warm. (2) Between pump and exhaust manifold. (3) EGR has back pressure system valve responsive to throttle.
3-12								
<u>1982 Buick Regal (PMP)</u>								
	Tom	Works	-	In gear	No	Yes	Yes	
Defect: TPS disconnected	Tim	Works (at 1000+ RPM)	-	No (see comment)	No	No	NT	Would not open w/ blocked exhaust or in gear.
<u>1984 Honda Civic (PLS)</u>								
	Tom	None	-	Yes (see comment)	No	Yes	Yes	Supposed to work only at 10+MPH, but cutout not operative.
Defect: Plugged EGR hose	Tim	None	-	Not by vac. (see comment)	Not open	Not open	NT	Vacuum controlled by solenoid. When manually applied at idle, engine stalls.

TABLE 3-2 (cont'd)  
 DIAGNOSIS OF EGR AND SECONDARY AIR IN CARB/3CL SYSTEMS

<u>Year/Make/Model</u>	<u>Mechanic</u>	<u>Diverter Valve</u>	<u>Check Valve</u>	<u>EGR Valve Working?</u>	<u>EGR at Idle?</u>	<u>EGR at Part Throttle</u>	<u>Cold Temp Vacuum Cutoff?</u>	<u>Comments</u>
<u>1982 AMC Concord (PMP)</u>								
	Tom	Works	Yes	Yes	No	Yes	Yes	
Defect: Ball bearing in vac line (air pump dumped)	Tim	Not diverting	Yes	Yes	No	No	NT	
<u>1984 Mitsubishi Tredia (PLS)</u>								
	Tom	None	Yes	Yes	No	Yes	Yes	Checked valve movement.
Defect: None	Tim	-	Works when warm	Yes (see comment)	No	Yes	NT	Standard-vacuum operated.
<u>1984 Chrysler New Yorker (PLS)</u>								
	Tom	Works	Yes	Yes	No	Yes	Yes	
Defect: CTS shorted	Tim	Works	Yes	Yes (see comment)	No	Yes	No	Cold temp. shut-off for EGR not working.

TABLE 3-2 (cont'd)  
 DIAGNOSIS OF EGR AND SECONDARY AIR IN CARB/3CL SYSTEMS

<u>Year/Make/Model</u>	<u>Mechanic</u>	<u>Diverter Valve</u>	<u>Check Valve</u>	<u>EGR Valve Working?</u>	<u>EGR at Idle?</u>	<u>EGR at Part Throttle</u>	<u>Cold Temp Vacuum Cutoff?</u>	<u>Comments</u>
<u>1984 Dodge Colt (PLS)</u>								
	Tom	See comment 1	-	Yes (see comment 2)	No	Yes	NT	(1) Hose disconnected from check valve. (2) Valve movement.
Defect: PLS blocked	Tim	Works (see comment)	-	Yes	No	Yes	NT	Line from div. valve to air cleaner blocked.
<u>1984 Nissan Sentra (PLS)</u>								
	Tom	See comment 1	-	Yes (see comment 2)	No	Yes	NT	(1) PLS-checked flow, disconnected hose. (2) Checked for valve movement.
Defect: PLS blocked	Tim	Blocked	-	Yes	No	Yes	NT	

TABLE 3-3

## CLOSED LOOP SYSTEM CHECK FOR CARB/3CL SYSTEMS

<u>Year/Make/Model</u>	<u>Mechanic</u>	<u>Fast Idle RPM/HC/CO</u>	<u>Oxy Disconnect RPM/HC/CO</u>	<u>Oxy to Ground RPM/HC/CO</u>	<u>Oxy to +VE RPM/HC/CO</u>	<u>Closed Loop Working?</u>	<u>Did Air Pump Dump?</u>	<u>Comments</u>
<u>1984 Isuzu I Mark</u>								
	Tom	1395/10/.1	1480/100/2.0	1480/100/2.0	1250/0/0	Yes	No	
Defect: Vac. leak at brake booster	Tim	1200/10/.02 2000/10/.02	1200/10/.02 2000/10/.02 (see comment 1)	1200/10/.02 2000/10/.02	Same (see comment 2)	-	Yes, always	(1) No voltage from O <sub>2</sub> sensor. (2) Cat. appears to mask effect of motor performance.
<u>1982 Buick Regal</u>								
	Tom	1900/0/0	1980/0/0	1980/0/0	1700/0/0	Yes (see comment)	No	Drop in speed, no change exh. readings.
Defect: TPS disconnected	Tim	1500/350/3.0	1500/350/3.0	No change.	1500/250/3.0	No	-	
<u>1984 Honda Civic</u>								
	Tom	1250/10/0	No OXS	-	-	See comment	-	Air bleed system operative.
Defect: Plugged EGR hose.	Tim	1800/10/.015	No OXS	-	-	None	None	

TABLE 3-3 (cont'd)  
CLOSED LOOP SYSTEM CHECK FOR CARB/3CL SYSTEMS

<u>Year/Make/Model</u>	<u>Mechanic</u>	<u>Fast Idle RPM/HC/CO</u>	<u>Oxy Disconnect RPM/HC/CO</u>	<u>Oxy to Ground RPM/HC/CO</u>	<u>Oxy to +VE RPM/HC/CO</u>	<u>Closed Loop Working?</u>	<u>Did Air Pump Dump?</u>	<u>Comments</u>
<u>1982 AMC Concord</u>								
	Tom	1400/10/11	1480/200/18	1480/100/2.0	1150/10/0	Yes	Yes (see comment)	At idle during OXS test.
Defect: Air pump dumped	Tim	1400/20/.2	1400/100/2.0	1000/10/.01	1100/10/.01	Yes	-	
<u>1984 Mitsubishi Tredia</u>								
	Tom	1350/10/0	1350/10/0	1350/10/0	1350/10/0	No	No	
Defect: None	Tim	1400/30/.02	No change	No change	No change	No	-	
<u>1984 Chrysler New Yorker</u>								
	Tom	1130/0/0	1200/20/.5 (see comment)	1160/0/0	1000/0/0	Yes	No	1100/130/1.0 with Elec. rad. fan on.
Defect: CTS shorted	Tim	1100/15/.02	1100/15/.02	No change	No change	No	-	
<u>1984 Dodge Colt</u>								
	Tom	1850/0/0	1880/200/3.1	1880/200/3.1	1800/0/0	Yes	No	
Defect: PLS blocked	Tim	1700/0/.01	1800/300/1.2	1600/0/.01	1600/0/.01	Yes	-	

3-16

TABLE 3-3 (cont'd)  
 CLOSED LOOP SYSTEM CHECK FOR CARB/3CL SYSTEMS

<u>Year/Make/Model</u>	<u>Mechanic</u>	<u>Fast Idle RPM/HC/CO</u>	<u>Oxy Disconnect RPM/HC/CO</u>	<u>Oxy to Ground RPM/HC/CO</u>	<u>Oxy to +VE RPM/HC/CO</u>	<u>Closed Loop Working?</u>	<u>Did Air Pump Dump?</u>	<u>Comments</u>
<u>1984 Nissan Sentra</u>								
	Tom	1650/0/.1	1800/200/5.0	1800/200/5.0	1100/0/0	Yes	No	
Defect: PLS blocked	Tim	1100/0/.01	1100/200/3	1100/0/0	700/0/0	Yes	-	When OXS disconnect- ed -- emissions jump- ed then went to clean by itself after 1 minute.

TABLE 3-4

## DEFECTS INTRODUCED AND IDENTIFIED IN CARB/3CL SYSTEMS

<u>Year/Make/Model</u>	<u>Mechanic</u>	<u>Additional Checks</u>	<u>Defects Identified</u>	<u>Defects Introduced</u>	<u>Comments</u>
<u>1984 Isuzu I-Mark</u>					
	Tom	CTS - no change.	-	Air leak at brake booster.	
	Tim	Test idle vacuum, since car had poor mid-range response, 20 Min. at idle.	*	*	
<u>1982 Buick Regal</u>					
	Tom	CTS open speed drop/0/.05, short - no change.	EGR clogged.	TPS open - NTC/100/3.0.	
	Tim		Cut wire to throttle sensor, rendered inoperative. When wire was fixed, closed loop started functioning fine.	Clogged EGR vacuum line.	
<u>1984 Honda Civic</u>					
	Tom	NT	None.	Plugged EGR hose.	See text.
	Tim	-	Found ball bearing in vacuum line to EGR -- removed	None.	



TABLE 3-4 (cont'd)

## DEFECTS INTRODUCED AND IDENTIFIED IN CARB/3CL SYSTEMS

<u>Year/Make/Model</u>	<u>Mechanic</u>	<u>Additional Checks</u>	<u>Defects Identified</u>	<u>Defects Introduced</u>	<u>Comments</u>
<u>1984 Chrysler New Yorker</u>					
	Tom	CTS open: 1000/0/0 short: 1170/0/0.	Choke closed; rich running.	CTS shorted.	No TPS check.
	Tim	Repeated tests for closed loop -- worked.	Shorted CTS.	Jammed choke plate closed -- high CO.	
<u>1984 Dodge Colt</u>					
	Tom	CTS -- no change; TPS too difficult to check.	Diverter valve to full vacuum.	PLS blocked.	
	Tim		Line to air cleaner from diverter valve blocked.	Put diverter valve on full vacuum -- used vacuum advance line.	
<u>1984 Nissan Sentra</u>					
	Tom	TPS -- no change; CTS not found.	PLS blocked.	Blocked PLS.	
	Tim		PLS blocked.	Blocked PLS.	

TABLE 3-4 (cont'd)  
 DEFECTS INTRODUCED AND IDENTIFIED IN CARB/3CL SYSTEMS

<u>Year/Make/Model</u>	<u>Mechanic</u>	<u>Additional Checks</u>	<u>Defects Identified</u>	<u>Defects Introduced</u>	<u>Comments</u>
<u>1982 Concord</u>					
	Tom	CTS open: 1470/70/1.5	TPS wire cut.	Air pump dumped at all times; ball bearing in vac. line to div. valve.	No TPS test -- one piece harness.
	Tim		Ball bearing in vacuum line to diverter valve. When connected, emissions went from 800/40/.1 to 800/40/.01.	Cut TPS wire.	
<u>1984 Mitsubishi Tredia</u>					
	Tom	TPS and CTS disconnect showed no change.	None.	None (see comment).	System check not possible.
	Tim	Put car on hoist, ran 50 MPH in drive -- no change as far as closed loop was concerned.	Could identify none.	None.	As above.

TABLE 3-5

## DIAGNOSIS OF EGR AND SECONDARY AIR IN CARB/3CL/OXD SYSTEMS

<u>Year/Make/Model</u>	<u>Mechanic</u>	<u>Diverter Valve</u>	<u>Check Valve</u>	<u>EGR Valve Working?</u>	<u>EGR at Idle?</u>	<u>EGR at Part Throttle</u>	<u>Cold Temp Vacuum Cutoff?</u>	<u>Comments</u>
<u>1983 Dodge Aries (PMP)</u>								
	Tom	Works	-	Yes	No	Yes	NT	
Defect: None (CL not working)	Tim	Works	-	Yes	No	Yes	NT	
<u>1984 Plymouth Reliant (PMP)</u>								
	Tom	Works	-	Yes	No	Yes	NT	
Defect: Computer not operative and div. valve cutoff	Tim	No (see comment)	-	Yes	No	Yes	NT	Ball bearing in vac. line.
<u>1983 Buick Century (PMP)</u>								
	Tom	Works	-	Yes	No	Yes	NT	
Defect: CTS disconnected	Tim	None	-	Yes	No	Yes (2000 RPM)	NT	
<u>1984 Ford Tempo (PMP)</u>								
	Tom	Works	-	No	No	No	NT	
Defect: Vacuum to MCS disconnected	Tim	Works (see comment)	Yes	Yes	No	Yes	NT	Diverted when cold.

TABLE 3-5 (cont'd)  
 DIAGNOSIS OF EGR AND SECONDARY AIR IN CARB/3CL/OXD SYSTEMS

<u>Year/Make/Model</u>	<u>Mechanic</u>	<u>Diverter Valve</u>	<u>Check Valve</u>	<u>EGR Valve Working?</u>	<u>EGR at Idle?</u>	<u>EGR at Part Throttle</u>	<u>Cold Temp Vacuum Cutoff?</u>	<u>Comments</u>
<u>1984 Oldsmobile Cutlass (PMP)</u>								
	Tom	Works	-	Yes (see comment)	No	Yes	Yes	In gear only.
Defect: None (EGR inoperative)	Tim	See comment 1	Yes	No (see comment 2)	No	No	NT	(1) Cold dump to cat. (2) Backpressure (EGR check).
<u>1984 Dodge Omni (PMP)</u>								
	Tom	None	-	Yes	No	High throttle only	Yes	
Defect: None (computer out)	Tim	Works	See comment	Yes	Closed	Open	Yes	2, one to Cat., one to manifold.
<u>1983 Chevrolet Monte Carlo (PMP)</u>								
	Tom	Works	-	Yes	No	Yes	Yes	
Defect: Air pump dumps always - vac. line rerouted	Tim	Dumps air	-	Yes	No	Yes	NT	

TABLE 3-5 (cont'd)

## DIAGNOSIS OF EGR AND SECONDARY AIR IN CARB/3CL/OXD SYSTEMS

<u>Year/Make/Model</u>	<u>Mechanic</u>	<u>Diverter Valve</u>	<u>Check Valve</u>	<u>EGR Valve Working?</u>	<u>EGR at Idle?</u>	<u>EGR at Part Throttle</u>	<u>Cold Temp Vacuum Cutoff?</u>	<u>Comments</u>
<u>1983 Pontiac Grand Prix (PMP)</u>								
	Tom	Works	Yes	Yes (see comment)	No	Yes	No	Checked for movement.
Defect: Air leak at carb base	Tim	Yes (see comment)	-	Yes	No	Yes	NT	Dumps to intake when cold.
<u>1984 Toyota SR-5 (PLS)</u>								
	Tom	None	-	Yes (see comment)	No	Yes	Yes	Valve movement checked.
Defect: None	Tim	Works	-	Yes	No	Yes	NT	
<u>1982 Pontiac 2000 (PMP)</u>								
	Tom	Works	-	Yes	No	Yes	Yes	EGR check - raise engine speed, check valve movement.
Defect: MCS short	Tim	See comment	-	Yes	No	No	NT	Diverting to air cleaner w/cold.

TABLE 3-5 (cont'd)  
 DIAGNOSIS OF EGR AND SECONDARY AIR IN CARB/3CL/OXD SYSTEMS

<u>Year/Make/Model</u>	<u>Mechanic</u>	<u>Diverter Valve</u>	<u>Check Valve</u>	<u>EGR Valve Working?</u>	<u>EGR at Idle?</u>	<u>EGR at Part Throttle</u>	<u>Cold Temp Vacuum Cutoff?</u>	<u>Comments</u>
<u>1984 Toyota Corolla (PLS)</u>								
	Tom	None	-	Yes	?	Yes	Yes	
Defect: None	Tim	None	-	Yes (see comment 1)	See comment 2	-	None	(1) Responds to vacuum. (2) Partly open at cold fast idle, closed at warm idle, opens at 1600 RPM.
<u>1981 Chevy Malibu (PMP)</u>								
	Tom	Works	NT	Yes	No	Yes	Yes	
Defect: Computer disconnected	Tim	None	Rusted & broken	Yes	-	-	NT	Air is being sent to cleaner.
<u>1983 Toyota Tercel</u>								
	Tom	None	-	None	-	-	NT	Test shortened to closed loop only.
Defect: None	Tim	None	-	None	-	-	NT	Test shortened (see text).

TABLE 3-5 (cont'd)

## DIAGNOSIS OF EGR AND SECONDARY AIR IN CARB/3CL/OXD SYSTEMS

<u>Year/Make/Model</u>	<u>Mechanic</u>	<u>Diverter Valve</u>	<u>Check Valve</u>	<u>EGR Valve Working?</u>	<u>EGR at Idle?</u>	<u>EGR at Part Throttle</u>	<u>Cold Temp Vacuum Cutoff?</u>	<u>Comments</u>
<u>1982 Plymouth Horizon (PMP)</u>								
	Tom	Works	-	Yes	No	High throttle only	Yes	
Defect: None	Tim	Works	Yes	Yes	Closed	Open	Yes	
<u>1983 Chevrolet Camaro (PMP)</u>								
	Tom	None	-	In gear	No	Yes	Yes	
Defect: EGR open always	Tim	See comment 1	Yes	Yes (see comment 2)	Yes	-	NT	(1) Air supply to catalyst. (2) Opens at 2000 RPM.
<u>1984 Toyota Corolla (PLS)</u>								
	Tom	None	-	Yes	See comment	-	NT	Difficult to see valve checked by hooking up vac. hose.
Defect: PLS blocked	Tim	None	-	Yes (see comment 1)	No	No	See comment 2	(1) Yes, under vacuum at idle engine -- stalls. (2) No vacuum to EGR.

TABLE 3-6  
CLOSED LOOP SYSTEM CHECK FOR CARB/3CL/OXD SYSTEMS

<u>Year/Make/Model</u>	<u>Mechanic</u>	<u>Fast Idle RPM/HC/CO</u>	<u>Oxy Disconnect RPM/HC/CO</u>	<u>Oxy to Ground RPM/HC/CO</u>	<u>Oxy to +VE RPM/HC/CO</u>	<u>Closed Loop Working?</u>	<u>Did Air Pump Dump?</u>	<u>Comments</u>
<u>1983 Dodge Aries</u>								
	Tom	1520/20/.05	1560/30/.05	1560/30/.05	1560/30/.05	No	No	CL cutoff switch on throttle.
Defect: None (CL not working)	Tim	1200/50/0	1200/60/.02	No change	-	No	-	CL cutoff not identified.
<u>1984 Plymouth Reliant</u>								
	Tom	1760/30/.01	No change	No change	No change	No	-	As above.
Defect: Computer not operative	Tim	1200/60/.02	1200/60/.02	1200/60/.02	1100/60/.02	?	No	
<u>1983 Buick Century</u>								
	Tom	NTC/20/0	Rise/70/.06	No change/ 70/.06	Drop & Surge/ 150/0	Yes	No	
Defect: CTS disconnected	Tim	1100/20/.15	Same	1100/-/-	See comment	-	-	500 RPM "Pulse"/-/.01 - OS
<u>1984 Ford Tempo</u>								
	Tom	1240/10/0	1310/170/2.3	1315/190/2.4	1100/10/0	Yes	No	
Defect: Vacuum to MCS disconnected	Tim	1100/40/.02	No change	No change	No change	No	?	



TABLE 3-6 (cont'd)

## CLOSED LOOP SYSTEM CHECK FOR CARB/3CL/OXD SYSTEMS

<u>Year/Make/Model</u>	<u>Mechanic</u>	<u>Fast Idle RPM/HC/CO</u>	<u>Oxy Disconnect RPM/HC/CO</u>	<u>Oxy to Ground RPM/HC/CO</u>	<u>Oxy to +VE RPM/HC/CO</u>	<u>Closed Loop Working?</u>	<u>Did Air Pump Dump?</u>	<u>Comments</u>
<u>1984 Toyota Corolla</u>								
	Tom	NTC/0/0	NTC/0/0	NTC/0/0	NTC/0/0 (see comment)	Yes	No	Speed drop - misfire.
Defect: None	Tim	850/50/0 1500/40/0	850/50/0 1500/40/0	850/40/0 1500/70/.2	850/50/0 1500/50/.1	No (see comment)	-	No voltage from O <sub>2</sub> sensor. Test at fast and regular idle.
<u>1981 Chevrolet Malibu</u>								
	Tom	1400/10/.1	1500/350/.7	1500/450/.9	1300/30/0 (see comment)	Yes	Yes	Slight delay.
Defect: Computer disconnected	Tim	1000/100/8	1000/100/8	1000/100/8	1000/100/8 (see comment 1)	No	Yes (see comment 2)	(1) No voltage from O <sub>2</sub> sensor. (2) Full-time.
<u>1983 Toyota Tercel</u>								
	Tom	1500/~0/~0	1500/~0/~0	1500/~0/~0	1500/~0/~0	Yes	-	Closed loop test works with raised engine speed and vacuum to lower carb hose.
Defect: None	Tim	1700/20/.01	1700/20/.01	1700/20/.01	1700/20/.01	No	-	No apparent change in RPM. While doing above, OXS voltage jumped from 0-.4 un- aided. Reconnect OXS -- no detectable change in CO or HC.

TABLE 3-6 (cont'd)  
CLOSED LOOP SYSTEM CHECK FOR CARB/3CL/OXD SYSTEMS

<u>Year/Make/Model</u>	<u>Mechanic</u>	<u>Fast Idle RPM/HC/CO</u>	<u>Oxy Disconnect RPM/HC/CO</u>	<u>Oxy to Ground RPM/HC/CO</u>	<u>Oxy to +VE RPM/HC/CO</u>	<u>Closed Loop Working?</u>	<u>Did Air Pump Dump?</u>	<u>Comments</u>
<u>1984 Olds Cutlass</u>								
	Tom	1100/0/0	1150/10/.1	No change	800/0/0 (see comment)	Yes	No	20 second delay.
Defect: None (EGR inoperative)	Tim	-	-	1500/80/.04	1200/40/.01	Yes	No	
<u>1984 Dodge Omni</u>								
	Tom	See comment	No change	No change	No change	No	No	Computer out.
Defect: None (computer out)	Tim	1500/100/.8 1000/30/.01 (see comment 1)	No change	No change	See comment 2	No	No	(1) No response from O <sub>2</sub> sensor. (2) No dwell at carb.
<u>1983 Chevrolet Monte Carlo</u>								
	Tom	1450/10/.1	1600/50/1.5	1600/50/1.5	1000/10/0	Yes	Yes (see comment)	Air pump dumps during OX5 disconnect.
Defect: Air pump dumps always	Tim	1400/10/.1	1600/50/1.5	1550/50/1.5	1050/10/0	Yes	Yes	

TABLE 3-6 (cont'd)  
CLOSED LOOP SYSTEM CHECK FOR CARB/3CL/OXD SYSTEMS

<u>Year/Make/Model</u>	<u>Mechanic</u>	<u>Fast Idle RPM/HC/CO</u>	<u>Oxy Disconnect RPM/HC/CO</u>	<u>Oxy to Ground RPM/HC/CO</u>	<u>Oxy to +VE RPM/HC/CO</u>	<u>Closed Loop Working?</u>	<u>Did Air Pump Dump?</u>	<u>Comments</u>
<u>1982 Plymouth Horizon</u>								
	Tom	1300/0/0	1300/0/0	1300/0/0	1100/0/0	Yes (see comment)	No	Carb switch must be disconnected to operate closed loop.
Defect: None	Tim	2000/-/-	No change	No change	1500/10/.01	Yes (see comment)	No	System is working in gear, but emissions are so negligible and so slight it is almost impossible to check effectively.
<u>1983 Chevrolet Camaro</u>								
	Tom	1100/30/0	1200/50/.3	1200/50/1.0	950/30/0	Yes	No	
Defect: EGR open always	Tim	1450/40/.005	1400/10/.8	No change	1200/0/.5	Yes (see comment)	Yes, Always	When air pump discon- nected from catalyst - CO to 8 percent. Re- connect OXS - normal.
<u>1984 Toyota Corolla</u>								
	Tom	NTC/20/0	No change/ 100/.5	No change/ 100/.5	Drop/200/.5	Yes	-	
Defect: PLS blocked	Tim	1250/35/.02	1250/150/.7	1250/130/.4	1150/150/1.2	Yes (see comment)	-	Air hose off vacuum control.

TABLE 3-6 (cont'd)  
CLOSED LOOP SYSTEM CHECK FOR CARB/3CL/OXD SYSTEMS

<u>Year/Make/Model</u>	<u>Mechanic</u>	<u>Fast Idle RPM/HC/CO</u>	<u>Oxy Disconnect RPM/HC/CO</u>	<u>Oxy to Ground RPM/HC/CO</u>	<u>Oxy to +VE RPM/HC/CO</u>	<u>Closed Loop Working?</u>	<u>Did Air Pump Dump?</u>	<u>Comments</u>
<u>1983 Pontiac Grand Prix</u>								
	Tom	1100/0/0	1170/0/0	1170/0/0	1000/0/0	Yes	Yes (see comment)	When carb. solenoid disconnected.
Defect: Air leak at carb base	Tim	1100/800/.2 (see comment)	1100/-/- 1200/0/0	1200/0/0	drop to 1100/0/0	Yes	-	Before fixing air leak.
<u>1984 Toyota SR-5</u>								
	Tom	1500/0/0	1500/0/0	1500/0/0	Slight drop/ 0/0	Yes	None	Two vacuum sensors -- lower sensor must be given vacuum to operate closed loop.
Defect: None	Tim	1750/80/.1	Same	1750/250.3	1600/100/.15	Yes	-	Put 15lbs+ to lower vacuum solenoid.
<u>1982 Pontiac 2000 (PMP)</u>								
	Tom	NTC/10/0	NTC/10/0	NTC/10/0	NTC/30/0 (see comment)	Yes	Yes	Speed drop to misfire.
Defect: MCS short	Tim	2000/400/7 1300/400/7.0	1500/100/ 1.2-1.4	1300/100/2.2	-/100/2.2 (see comment 1)	No	No (see comment 2)	(1) Instant 200 RPM drop to 1300. (2) OXS gives .8 volt @ 1600 RPM.

TABLE 3-7

## DEFECTS INTRODUCED AND IDENTIFIED IN CARB/3CL/OXD SYSTEMS

<u>Year/Make/Model</u>	<u>Mechanic</u>	<u>Additional Checks</u>	<u>Defects Identified</u>	<u>Defects Introduced</u>	<u>Comments</u>
<u>1983 Dodge Aries</u>					
	Tom	CTS -- no change.	Computer not operative.	None, as CL did not work as received.	Later discovered to be microswitch problem.
	Tim	MCS not clicking but giving 2° dwell readings.	Computer not operative.	As above.	
<u>1984 Plymouth Reliant</u>					
	Tom		Computer not operative.	Diverter valve vacuum cutoff.	Later discovered to be microswitch problem.
	Tim		Ball bearing in line (vacuum) to diverter valve.	None, as CL did not work.	Closed loop not working, computer defective?
<u>1983 Buick Century</u>					
	Tom	CTS open: speed rise/0/.01 CTS short: speed rise/0/.01 TPS open: speed rise/30/0 (see comment)	OXS grounded.	CTS disconnected.	No tach connection.
	Tim		CTS cut.	OXS grounded.	

TABLE 3-7 (cont'd)  
DEFECTS INTRODUCED AND IDENTIFIED IN CARB/3CL/OXD SYSTEMS

<u>Year/Make/Model</u>	<u>Mechanic</u>	<u>Additional Checks</u>	<u>Defects Identified</u>	<u>Defects Introduced</u>	<u>Comments</u>
<u>1984 Ford Tempo</u>					
	Tom	CTS open 1280/20/0 CTS short 1740/30/0	Wire to TPS disconnected.	Vacuum to MCS disconnected.	Diverter valve access difficult; EGR inoperative; possibly only works in gear.
	Tim		Diverter valve vacuum line plugged.	TPS disconnected.	
<u>1984 Toyota Corolla</u>					
	Tom	Good access to all components.	See comment.	See comment.	Due to system peculiarities, no defects could be introduced (see text).
	Tim	PLS disconnected; O <sub>2</sub> connected 850/220/.4 disconnect 850/220/.8 ground 850/170/.2 battery + ve 850/160/.2	See comment.	See comment.	As above.

TABLE 3-7 (cont'd)  
 DEFECTS INTRODUCED AND IDENTIFIED IN CARB/3CL/OXD SYSTEMS

<u>Year/Make/Model</u>	<u>Mechanic</u>	<u>Additional Checks</u>	<u>Defects Identified</u>	<u>Defects Introduced</u>	<u>Comments</u>
<u>1981 Chevrolet Malibu</u>					
	Tom	PMP dumped: 1540/0/0 CTS shorted: 1450/0/0 MCS open: 1450/2/8	N/A	Computer disconnected.	
	Tim	Computer malfunction suspected due to total lack of response from all systems.	No signal to MCS until computer diagnosis circuit is grounded -- code 23 & 55 indicated; open MCS circuit, short or no power to computer.	None.	Lack of coordination prevented defect introduction.
<u>1983 Toyota Tercel</u>					
	Tom		See comment.	None.	Peculiar system; difficult to diagnose.
	Tim	Disconnect Right Vac. Sw. 1800/0/0 Disconnect Left Vac. Sw. 1800/0/0	Disconnected and plugged vac. line from EBCV* to slow air bleed port -- no change; disconnected vacuum from EBCV to main air bleed port -- no change; disconnected wire from computer to EBCV -- no change; 1800 RPM → pull off computer wire to EBCV, quick CO surge, then back to normal.	None.	As above.

\*EBCV = Electric Bleed Control Valve

TABLE 3-7 (cont'd)  
DEFECTS INTRODUCED AND IDENTIFIED IN CARB/3CL/OXD SYSTEMS

<u>Year/Make/Model</u>	<u>Mechanic</u>	<u>Additional Checks</u>	<u>Defects Identified</u>	<u>Defects Introduced</u>	<u>Comments</u>
<u>1984 Olds Cutlass</u>					
	Tom	Freq. valve open - pump dumps NTC/100/.8 CTS open - air pump dumps NTC/50/.3	Frequency valve open.	See comment.	EGR was inoperative as received.
	Tim		See comment.	Disconnected frequency valve.	As above.
<u>1984 Dodge Omni</u>					
	Tom		See comment.	None.	Computer out.
	Tim	Entire system is grounding somewhere; CTS, TPS ok -- carburetor always grounded, as are frequency solenoid leads; suspect bad computer.	See comment.	None.	Computer out.
<u>1983 Chevrolet Monte Carlo</u>					
	Tom	CTS open 1500/20/.6 short 1410/10/.2 TPS open 1600/50/1.6	OXS disconnect.	Air pump dumps always; vacuum line.	Had to splice OXS wire to conduct test.
	Tim		Air pump always dumps.	OXS disconnect.	Vac. line repaired.



TABLE 3-7 (cont'd)

## DEFECTS INTRODUCED AND IDENTIFIED IN CARB/3CL/OXD SYSTEMS

<u>Year/Make/Model</u>	<u>Mechanic</u>	<u>Additional Checks</u>	<u>Defects Identified</u>	<u>Defects Introduced</u>	<u>Comments</u>
<u>1982 Plymouth Horizon</u>					
	Tom	CTS -- no change.	None.	None.	Microswitch discovered on Chrysler cars.
	Tim	See comment.	None.	None.	Unable to discover switch, but CL works in gear under load.
<u>1983 Chevrolet Camaro</u>					
	Tom	CTS open: 1200/100/1.1 CTS short: 1150/50/.3 TPS disc: 1230/300/6.0	TPS cut (wires).	EGR open always.	
	Tim		Couldn't find any CL problems but found the idle to be rough; EGR lines improperly connected.	Cut TPS wire.	
<u>1984 Toyota Corolla</u>					
	Tom	CTS open -- no change; short -- no change.	Vacuum line to closed loop control plugged.	PLS blocked.	Must disconnect middle vac. hose to operate closed loop.
	Tim		Couldn't find any.	Incapacitated close-loop solenoid.	(PLS block not detected.)

TABLE 3-7 (cont'd)

## DEFECTS INTRODUCED AND IDENTIFIED IN CARB/3CL/OXD SYSTEMS

<u>Year/Make/Model</u>	<u>Mechanic</u>	<u>Additional Checks</u>	<u>Defects Identified</u>	<u>Defects Introduced</u>	<u>Comments</u>
<u>1983 Pontiac Grand Prix</u>					
	Tom	CTS open: 1200/100/4.5 CTS short: 1120/0/0 TPS open: 1228/40/6.5 TPS short: 1090/0/0 1170/0/0	MCS shorted -- no noise during ign. on.	Air leak at carb base.	
	Tim		Vacuum leak -- wire in intake manifold (propping carb up from base).	Shorted MCS.	
<u>1984 Toyota SR-5</u>					
	Tom	CTS open -- no change.	None.	None.	Peculiar system, see text.
	Tim		None.	None.	As above.
<u>1982 Pontiac 2000 (PMP)</u>					
	Tom	MCS open: speed rise/100/1.8 CTS open: speed drop/50/1.8	OXS shorted to ground.	Shorted MCS.	Good access to all components.
	Tim		MCS not clicking.	OXS short.	

TABLE 3-8

## DIAGNOSIS OF EGR AND SECONDARY AIR IN TBI SYSTEMS

<u>Year/Make/Model</u>	<u>Mechanic</u>	<u>Diverter Valve</u>	<u>Check Valve</u>	<u>EGR Valve Working?</u>	<u>EGR at Idle?</u>	<u>EGR at Part Throttle</u>	<u>Cold Temp Vacuum Cutoff?</u>	<u>Comments</u>
<u>1983 Renault Alliance</u>								
	Tom	None	-	Yes	Yes	Yes	NT	
Defect: None	Tim	None	-	Yes	Closed	Yes	None locatable	
<u>1983 Cadillac deVille (PMP)</u>								
	Tom	Works	-	Yes	No	Yes	NT	
Defect: TPS shorted	Tim	Not Operating (see comment 1)	-	No	Closed	Closed	Works when warm (see comment 2)	(1) Diverting to air cleaner. (2) Diverter valve and EGR solenoid getting vacuum at input terminals.
<u>1983 Chevrolet Celebrity</u>								
	Tom	None	-	See comment 1	-	-	See comment 2	(1) EGR not visible. (2) Direct to throttle body.
Defect: Air leak	Tim	None	-	Yes	Closed	Closed	NT	Used mirror to locate EGR.
<u>1983 Renault Alliance</u>								
	Tom	None	-	Yes	No	Yes	None	
Defect: TPS shorted	Tim	None	-	Yes	Closed	Part open	None	

TABLE 3-8 (cont'd)

## DIAGNOSIS OF EGR AND SECONDARY AIR IN TBI SYSTEMS

<u>Year/Make/Model</u>	<u>Mechanic</u>	<u>Diverter Valve</u>	<u>Check Valve</u>	<u>EGR Valve Working?</u>	<u>EGR at Idle?</u>	<u>EGR at Part Throttle</u>	<u>Cold Temp Vacuum Cutoff?</u>	<u>Comments</u>
<u>1984 Ford T-bird (PMP)</u>								
	Tom	Works	-	Yes	No	Yes	Yes	
Defect: Vacuum leak to PMP; dump always	Tim	See comment 1	Yes	Yes (see comment 2)	Closed	Open @ 1500	See comment 3	(1) Solenoid/vacuum activated -- check valve in line to catalyst and intake manifold. (2) ≈1500 w/back pressure. (3) Solenoid control, presumably with computer command.
<u>1983 Chevrolet Citation</u>								
	Tom	None	-	Yes (see comment)	No	Yes	Yes	EGR checked for movement.
Defect: No gap #4 plug; high HC	Tim	None	-	Yes (see comment)	No	Yes	NT	Standard vacuum.
<u>1984 Ford Crown Victoria (PMP)</u>								
	Tom	Works	-	Yes (see comment)	No	Yes	Yes	Checked for movement.
Defect: MPS disconnected; rich running	Tim	Works	-	Yes (see comment)	No	Yes	NT	Std. vacuum operated.

TABLE 3-8 (cont'd)

## DIAGNOSIS OF EGR AND SECONDARY AIR IN TBI SYSTEMS

<u>Year/Make/Model</u>	<u>Mechanic</u>	<u>Diverter Valve</u>	<u>Check Valve</u>	<u>EGR Valve Working?</u>	<u>EGR at Idle?</u>	<u>EGR at Part Throttle</u>	<u>Cold Temp Vacuum Cutoff?</u>	<u>Comments</u>
<u>1984 Lincoln Town Car (PMP)</u>								
	Tom	Works	-	Yes (see comment)	No	Yes	Yes	Checked for movement.
Defect: MPS shorted	Tim	Works	Yes	Yes (see comment)	No	Yes	NT	Vacuum operated.
<u>1984 Pontiac Firenza</u>								
	Tom	None	-	Yes (see comment)	No	Yes	Yes	Checked for movement.
Defect: TPS shorted	Tim	None	-	Yes (see comment)	No	Yes	NT	Vacuum operated -- standard.
<u>1984 Chrysler E-Class (PLS)</u>								
	Tom	Works	Yes	Yes (see comment)	No	Yes	Yes	Checked for movement.
Defect: Small hole in MPS hose	Tim	Works	-	See comment	-	-	NT	No EGR -- couldn't find.
<u>1983 Mercury Grand Marquis (PMP)</u>								
	Tom	Works	Yes	Yes	No	Yes	Yes	
Defect: Computer out as received	Tim	Good	-	Yes	No	No	NT	

TABLE 3-8 (cont'd)  
DIAGNOSIS OF EGR AND SECONDARY AIR IN TBI SYSTEMS

<u>Year/Make/Model</u>	<u>Mechanic</u>	<u>Diverter Valve</u>	<u>Check Valve</u>	<u>EGR Valve Working?</u>	<u>EGR at Idle?</u>	<u>EGR at Part Throttle</u>	<u>Cold Temp Vacuum Cutoff?</u>	<u>Comments</u>
<u>1984 Buick Skylark</u>								
	Tom	None	-	Yes (see comment)	No	Yes	Yes	Valve checked for movement.
Defect: Small hole in MPS hose	Tim	None	-	Yes	No	Yes	None	
<u>1984 Pontiac 6000</u>								
	Tom	None	-	Yes (see comment)	No	Yes	Yes	Valve movement.
Defect: MPS hose routed incorrectly	Tim	None	-	Yes	Yes (see comment)	Yes	NT	Lines reversed (see defects).
<u>1982 Pontiac Firebird (PMP)</u>								
	Tom	Leaking (broken)	-	Yes (see comment)	No	Yes	Yes	Movement checked.
Defect: None	Tim	Works (see comment)	-	Yes	No	Yes	-	Diverter valve is broken - emissions are very high.

TABLE 3-9  
CLOSED LOOP SYSTEM CHECK FOR TBI SYSTEMS

<u>Year/Make/Model</u>	<u>Mechanic</u>	<u>Fast Idle RPM/HC/CO</u>	<u>Oxy Disconnect RPM/HC/CO</u>	<u>Oxy to Ground RPM/HC/CO</u>	<u>Oxy to +VE RPM/HC/CO</u>	<u>Closed Loop Working?</u>	<u>Did Air Pump Dump?</u>	<u>Comments</u>
<u>1983 Renault Alliance</u>								
	Tom	950/<10/<.1 (see comment)	950/<10/<.1	950/<10/<.1	840/<10/<.1	Yes	No	In gear.
Defect: None	Tim	650/200/.6 (Idle)	650/100/ .1-1.0	650/100/.1	700/250/1.5 500/350/4.5	No (at idle)	-	Not working at low RPM.
<u>1983 Cadillac deVille (PMP)</u>								
	Tom	NTC/0/.1	NTC/10/.1	NTC/10/.1	NTC/190/.1 (speed drop)	Yes	No	
Defect: TPS shorted	Tim	700/800/.3	700/700/.4	700/400/3-5	700/400/<.5	No	Yes (always)	
<u>1983 Chevrolet Celebrity</u>								
	Tom	NTC/20/.3	NTC/10/.5 (see comment 1)	NTC/40/2.0 (see comment 1)	NTC/10/.1 (see comment 2)	Yes	No	(1) No change. (2) Slight speed drop.
Defect: Air leak	Tim	1100/100/1.3	1100/90/1.13	1100/250/3.5	900/60/.09	Yes	No	Sensor voltage -- disconnected OXS .1V to positive 0V to negative .6V

TABLE 3-9 (cont'd)  
CLOSED LOOP SYSTEM CHECK FOR TBI SYSTEMS

<u>Year/Make/Model</u>	<u>Mechanic</u>	<u>Fast Idle RPM/HC/CO</u>	<u>Oxy Disconnect RPM/HC/CO</u>	<u>Oxy to Ground RPM/HC/CO</u>	<u>Oxy to +VE RPM/HC/CO</u>	<u>Closed Loop Working?</u>	<u>Did Air Pump Dump?</u>	<u>Comments</u>
<u>1983 Renault Alliance</u>								
	Tom	1600/10/0	1600/20/.1	No change	1300/0/0 (see comment)	Yes	No	Slight delay.
Defect: TPS shorted	Tim	800/170/.18	900/270/1.9	800/150/1.1	700/80/.02	Yes	Yes	
<u>1984 Ford T-Bird (PMP)</u>								
	Tom	NTC/50/.1	NTC/70/.1 (see comment 1)	NTC/70/.1 (see comment 1)	NTC/40/.05 (see comment 2)	Yes	No	(1) No change. (2) Speed drop. (3) Relay suspected - once defect in- duced, closed loop had to be reset by restart- ing motor after disconnecting battery.
Defect: Vacuum leak to PMP	Tim	650/40/.01 (see comment 1)	650/40/.01	650/40/.01	650/40/.01	No (see comment 2)	No	(1) Idle. (2) No response; lean mixture but no lean misfire.
<u>1983 Chevrolet Citation</u>								
	Tom	1450/50/.6	1450/50/.3	1500/450/10+	1100/400/.1	Yes	None	
Defect: No gap in #4 plug	Tim	1700/30/.2	1800/100/1.2	1500/2000/10	1000/100/.5	Yes	No	



TABLE 3-9 (cont'd)  
CLOSED LOOP SYSTEM CHECK FOR TBI SYSTEMS

<u>Year/Make/Model</u>	<u>Mechanic</u>	<u>Fast Idle RPM/HC/CO</u>	<u>Oxy Disconnect RPM/HC/CO</u>	<u>Oxy to Ground RPM/HC/CO</u>	<u>Oxy to +VE RPM/HC/CO</u>	<u>Closed Loop Working?</u>	<u>Did Air Pump Dump?</u>	<u>Comments</u>
<u>1984 Ford Crown Victoria (PMP)</u>								
	Tom	1100/40/0	1110/30/0	780/0/0 (see comment 1)	625/0/0 (see comment 1)	Yes (see com- ment 2)	No (see com- ment 3)	(1) In gear. (2) Must be in gear. (3) During TPS test only.
Defect: MPS disconnected	Tim	NTC/--/9	NTC/200/9	See comment	See comment	See comment	?	Car stalled persis- tently; could not keep running.
<u>1984 Lincoln Town Car (PMP)</u>								
	Tom	1100/10/0	1100/0/0	790/200/4.2 (see comment)	650/0/0	Yes	No	In gear.
Defect: MPS shorted	Tim	2000/500/3	2000/250/1.75	2000/75/.5	1400/800/4	Yes	-	
<u>1984 Pontiac Firenza</u>								
	Tom	1800/0/0	1800/0/0	1950/250/10	1410/0/0	Yes	None	
Defect: TPS shorted	Tim	1900/100/1.0	-	2200/400/3	1600/50/.1	Yes	-	
<u>1984 Chrysler E-Class (PLS)</u>								
	Tom	1950/50/.2	1800/40/0	2150/270/6.0	1470/80/0	Yes	No	
Defect: Small hole in MPS hose	Tim	1000/200/2.5	Same	Same	Same	No	-	

TABLE 3-9 (cont'd)  
CLOSED LOOP SYSTEM CHECK FOR TBI SYSTEMS

<u>Year/Make/Model</u>	<u>Mechanic</u>	<u>Fast Idle RPM/HC/CO</u>	<u>Oxy Disconnect RPM/HC/CO</u>	<u>Oxy to Ground RPM/HC/CO</u>	<u>Oxy to +VE RPM/HC/CO</u>	<u>Closed Loop Working?</u>	<u>Did Air Pump Dump?</u>	<u>Comments</u>
<u>1983 Mercury Grand Marquis (PMP)</u>								
	Tom	1300/0/0	1580/400/0.8	1500/400/0.8	1500/400/0.8 (see comment 1)	No	Yes (see comment 2)	(1) No change. (2) During first idle.
Defect: Computer out as received	Tim	1100/20/.02	Same	Same	Same	No	No	
<u>1984 Buick Skylark</u>								
	Tom	1380/20/1.3	1350/0/0	1430/200/4.5	1200/0/0	Yes	None	
Defect: Small hole in MPS hose	Tim	1200/200/.3	1200/250/1.4	1200/800/7.5	1100/80/.02	Yes	-	
<u>1984 Pontiac 6000</u>								
	Tom	1200/0/0	1500/100/2.5	1500/650/8.0	1300/0/0	Yes	None	
Defect: MPS hose routed incorrectly	Tim	1850/100/.3	1650/100/.1	2000/120/1.8	1200/no change	Yes	-	
<u>1982 Pontiac Firebird</u>								
	Tom	1150/30/1.0	1150/30/1.0	-	See comment	Yes	No	Died (rich running?)
Defect: None	Tim	1150/100/.5	1150/60/1.6	1150/60/1.6	See comment	Yes	No	Makes mixture so rich it stalls.

TABLE 3-10

## DEFECTS INTRODUCED AND IDENTIFIED IN TBI SYSTEMS

<u>Year/Make/Model</u>	<u>Mechanic</u>	<u>Additional Checks</u>	<u>Defects Identified</u>	<u>Defects Introduced</u>	<u>Comments</u>
<u>1983 Renault Alliance</u>					
	Tom	CTS did not effect speed or exh TPS open: 950/<10/<.1 TPS short: 1120/20/2.0	OXS short found.	None.	Closed loop functional only with car in forward gear. Radiator fan slowed motor noticeably. Good access to most components.
	Tim	OXS voltage 1.4 volts between grounded sensor and hot. Sensor grounded -- not producing voltage. Not grounded -- suspect test instrument. Idle and CO/HC readings increase during closed- loop check.	See comments.	OXS short.	Systems responses become more normal @2000 RPM, although grounding harness causes no change. Closed-loop check drops RPM fractionally but with little or no change in HC/CO readings. Overall systems checks do not seem to work well with this car at normal idle speeds w/car in neutral.

TABLE 3-10 (cont'd)

## DEFECTS INTRODUCED AND IDENTIFIED IN TBI SYSTEMS

<u>Year/Make/Model</u>	<u>Mechanic</u>	<u>Additional Checks</u>	<u>Defects Identified</u>	<u>Defects Introduced</u>	<u>Comments</u>
<u>1983 Cadillac deVille (PMP)</u>					
	Tom	CTS open: NTC/10/.1 Vac.sens. open: NTC/10/.1 (Engine light on) TPS shorted: NTC/50/.5 (air pump dumped).	None.	TPS shorted; CO and HC off scale.	Computer readout not accurate, memoray erased, but no correct diagnos- tic.
	Tim		No EGR, diverter valve dumps air, incorrect vacuum routing.	None.	Final reading - EGR operative, air to converter 600/500/.4
<u>1983 Chevrolet Celebrity</u>					
	Tom	CTS open: speed rise/20/.1 CTS short: speed rise/10/.3	EGR valve blocked.	Vac. leak NTC/1400/.5+ varying.	
	Tim	As indicated by the OXS check (no engine response -- high CO when grounding sensor harness).	Vac. leak.	Blocked EGR valve.	
<u>1983 Renault Alliance</u>					
	Tom	CTS -- no change.	None.	TPS shorted NTC/400/4.0	
	Tim		No start with TPS disconnect as no	Unable to start. No defect intro-	

TABLE 3-10 (cont'd)  
DEFECTS INTRODUCED AND IDENTIFIED IN TBI SYSTEMS

<u>Year/Make/Model</u>	<u>Mechanic</u>	<u>Additional Checks</u>	<u>Defects Identified</u>	<u>Defects Introduced</u>	<u>Comments</u>
<u>1984 Ford T-Bird</u>					
	Tom	CTS open: no change/40/.1 CTS short: no change/40/.05 MPS open: speed up/160/.2 MPS Short: drop and rise/30/.05	*	Vac. leak to air -- dumps always.	Electronic defects.
	Tim		Vac. leak to hose for diverter valve.	*	Air pump works at low pressure, diagnosis diffi- cult.
<u>1983 Chevrolet Citation</u>					
	Tom	CTS open: 1870/20/.4 CTS short: 1850/20/.4 TPS Open: 1650/20/.3	Shorted TPS.	No gap #4 plug -- high HC.	
	Tim	Engine has serious misfire.	Found crud in spark plug cap on #4 Cyl and #3 -- #4 plug, no gap.	Shorted out TPS.	Plug defect detect- ed from rough run- ning.

TABLE 3-10 (cont'd)  
 DEFECTS INTRODUCED AND IDENTIFIED IN TBI SYSTEMS

<u>Year/Make/Model</u>	<u>Mechanic</u>	<u>Additional Checks</u>	<u>Defects Identified</u>	<u>Defects Introduced</u>	<u>Comments</u>
<u>1984 Ford Crown Victoria</u>					
	Tom	TPS short Green/Orange NTC/30/4.0 Air pump dumped TPS open 1350/0/0 TPS short 1060/10/0 MPS open 1420/0/0 MPS short 1030/10/0	Found TPS shorted, ran rich.	MPS disconnected, rich running.	
	Tim		Disconnected MPS.	Shorted TPS.	
<u>1984 Lincoln Town Car</u>					
	Tom	MPS open 950/OS/7.0 MPS short died/0/0 TPS open 1000/20/0 TPS short 1050/200/8.5 Other combinations -- died.	MPS shorted.	MPS shorted.	CTS open 1260/0/.10 short 1250/0/.10 Car had some sort of memory that would remain until car was restarted.
	Tim	Very rich mixture; checked vacuum mix- ture; final 750/100/.6	Wire to vac. sensor cut.	Recut wire to vac. sensor.	Voltage readings from sensor were .2 + .4.

TABLE 3-10 (cont'd)

## DEFECTS INTRODUCED AND IDENTIFIED IN TBI SYSTEMS

<u>Year/Make/Model</u>	<u>Mechanic</u>	<u>Additional Checks</u>	<u>Defects Identified</u>	<u>Defects Introduced</u>	<u>Comments</u>
<u>1984 Pontiac Firenza</u>					
	Tom	CTS open: no change CTS short: no change TPS open: 1920/0/0	Vacuum switch open rich running.	TPS shorted.	
	Tim	Normal idle: 1150/130/1.75 Grounded OXS harness: NTC/225/7.0	TPS short.	Disconnected vac. switch.	Diagnostic readings: CTS, TPS, harness Computer malfunction.
<u>1984 Chrysler E-Class</u>					
	Tom	MPS Open 1800/0S/0S CTS open 1800/40/0 CTS short 1800/40/0 (see comment).	Hole in MPS hose.	Hole in MPS hose.	TPS - no check possible due to one piece harness.
	Tim	At idle - output voltage of OXS -- none; under accel - .1 volt; checked MCS; put in gear -- NTC/20/.01.	Cut vac. pres. sens. line.	None.	Defect not located.

TABLE 3-10 (cont'd)  
DEFECTS INTRODUCED AND IDENTIFIED IN TBI SYSTEMS

<u>Year/Make/Model</u>	<u>Mechanic</u>	<u>Additional Checks</u>	<u>Defects Identified</u>	<u>Defects Introduced</u>	<u>Comments</u>
<u>1983 Mercury Grand Marquis</u>					
	Tom	CTS open 1820/0/.3 CTS short 1600/0/0 MPS open 1320/0S/3.0 MPS short NTC/0/0	None (Computer out).	None, closed loop inoperative as received.	TPS open 1500/0/0 short 1200/0/0
	Tim		None (Computer out).	None (Computer out).	
<u>1984 Buick Skylark</u>					
	Tom	CTS open 1820/0/.3 CTS short 1820/0/.3 TPS open 1380/100/.3 TPS short NTC/1000/0S MPS open 800/0S/0S	OXS disconnected.	Small hole in MPS hose.	
	Tim		Manifold pressure sensor line had hole.	Cut wire to harness from OXS.	
<u>1984 Pontiac 6000</u>					
	Tom	CTS open 1950/0/0 short 1950/0/0 TPS open 1500/10/0 short 1500/1000/5.0 MPS open 820/0S/0S	None found.	MPS hose routed incorrectly; rich running.	Did not check OXS physically.
	Tim		Vacuum lines to EGR and manifold vacuum were reversed.	Pinched all openings on OXS.	



TABLE 3-10 (cont'd)  
 DEFECTS INTRODUCED AND IDENTIFIED IN TBI SYSTEMS

<u>Year/Make/Model</u>	<u>Mechanic</u>	<u>Additional Checks</u>	<u>Defects Identified</u>	<u>Defects Introduced</u>	<u>Comments</u>
<u>1982 Pontiac Firebird</u>					
	Tom	CTS open 1400/40/.6 TPS open 1000/100/.2 TPS short 1150/250/7.0 MPS open 1200/240/6.5	OXS open, melted wire.	None.	
	Tim		None.	Disconnected wire from OXS to harness.	

TABLE 3-11

## CLOSED LOOP SYSTEM CHECK FOR MFI/3CL SYSTEMS

<u>Year/Make/Model</u>	<u>Mechanic</u>	<u>Fast Idle RPM/HC/CO</u>	<u>Oxy Disconnect RPM/HC/CO</u>	<u>Oxy to Ground RPM/HC/CO</u>	<u>Oxy to +VE RPM/HC/CO</u>	<u>Closed Loop Working?</u>	<u>Did Air Pump Dump?</u>	<u>Comments</u>
<u>1983 VW Rabbit</u>								
	Tom	1200/10/.5	1200/0/0	1200/0/0	700/0/0	Yes	None	
Defect: Air leak	Tim	1300/50/.3	1300/30/.2	1250/150/6	700/30/.05	Yes	-	
<u>1984 VW Rabbit</u>								
	Tom	1120/30/0	1120/30/0	1200/110/1.5	530/30/0	Yes	None	
Defect: CO adjusted to 3.0 percent at fuel distribution	Tim	1800/01/.2	2000/100/7.0	No change	1800/30/.1	Yes	-	
<u>1983 BMW 320i</u>								
	Tom	1100/70/.6	900/150/.4	900/150/.4	Died	Yes	None	
Defect: Bad spark plug	Tim	1700/2000+/ 1.2	1400/2000+/ .01	1750/2000+/ 3.5	800/2000+/ .1	Yes	-	
<u>1981 Saab 900T</u>								
	Tom	1200/0/.5	1500/0/2.0	1500/0/2.0	900/0/0	Yes	None	
Defect: Bad injector	Tim	1500/5/.2	1600/50/3.2	No change	1100/20/0	Yes	-	

TABLE 3-11 (cont'd)  
 CLOSED LOOP SYSTEM CHECK FOR MFI/3CL SYSTEMS

<u>Year/Make/Model</u>	<u>Mechanic</u>	<u>Fast Idle RPM/HC/CO</u>	<u>Oxy Disconnect RPM/HC/CO</u>	<u>Oxy to Ground RPM/HC/CO</u>	<u>Oxy to +VE RPM/HC/CO</u>	<u>Closed Loop Working?</u>	<u>Did Air Pump Dump?</u>	<u>Comments</u>
<u>1983 Peugeot 505 (PLS)</u>								
	Tom	1300/0/0	1160/0/0	1300/0/0	750/0/0	Yes	None	
Defect: Frequency valve disconnected	Tim	1400/30/.02	1400/250/9.0	1400/50/.3	900/10/.01	Yes (see comment)	-	After reconnection of frequency valve.
<u>1983 Volvo 245 Turbo</u>								
	Tom	1500/80/1.0	1660/100/1.0	1660/100/1.0	1250/0/0	Yes	None	
Defect: Frequency valve disconnected	Tim	1550/0/.01	1700/100/2.4	1600/100/5.5	1200/60/.1	Yes	-	

TABLE 3-12

## DEFECTS INTRODUCED AND IDENTIFIED IN MFI/3CL SYSTEMS

<u>Year/Make/Model</u>	<u>Mechanic</u>	<u>Additional Checks</u>	<u>Defects Identified</u>	<u>Defects Introduced</u>	<u>Comments</u>
<u>1983 VW Rabbit</u>					
	Tom	No other sensors.	Altered air flow sensor NTC/300/3.0	Air leak.	All checks very easy. Tachometers on most controls.
	Tim		Air leak.	Altered air flow sensor.	
<u>1984 VW Rabbit</u>					
	Tom	No other checks.	None.	CO adjusted to 3.0 percent at fuel distributor.	
	Tim		Idle mixture changed.	None.	
<u>1983 BMW 320i</u>					
	Tom	CTS open - no change. Wires to warm up regulator disconnected. Slow RPM drop during warm up, no change when warm.	OXS disconnected.	Bad spark plug; (high HC)	
	Tim		#1 plug bad.	Disconnected OXS from harness.	

TABLE 3-12 (cont'd)

## DEFECTS INTRODUCED AND IDENTIFIED IN MFI/3CL SYSTEMS

<u>Year/Make/Model</u>	<u>Mechanic</u>	<u>Additional Checks</u>	<u>Defects Identified</u>	<u>Defects Introduced</u>	<u>Comments</u>
<u>1981 Saab 900T</u>					
	Tom	No change - warm running w/warm up. Regulator wires disconnected.	Mixture adjusted (too rich at distributor).	Bad injector (rich running).	
	Tim		Bad injector on Cyl #4 (HC & CO high).	Adjusted idle mixture (rich).	
<u>1983 Peugeot 505</u>					
	Tom	Warm up regulator wire disconnected - slow CO drop at warm up but no change once warm.	Air leak at vac. hose (lean running).	Frequency valve disconnected (lean running).	
	Tim		Frequency valve electrical connection disconnected.	Disconnected vacuum line.	Throttle has micro-switch. At closed throttle, closed loop would not work. Worked when throttle was opened.
<u>1983 Volvo 245T</u>					
	Tom		OXS disconnected.	Frequency valve disconnected.	
	Tim		Frequency valve	Cut OXS (ran rich).	

TABLE 3-13

## DIAGNOSIS OF EGR AND SECONDARY AIR IN EFI/3CL SYSTEMS

<u>Year/Make/Model/</u>	<u>Mechanic</u>	<u>Diverter Valve</u>	<u>Check Valve</u>	<u>EGR Valve Working?</u>	<u>EGR at Idle?</u>	<u>EGR at Part Throttle</u>	<u>Cold Temp Vacuum Cutoff?</u>	<u>Comments</u>
<u>1983 Nissan Maxima</u>								
	Tom	None	-	Yes	No	Yes	Yes	
Defect: Adjusted TPS	Tim	None	-	Yes	No	Yes	NT	
<u>1983 Volvo 244</u>								
	Tom	None	-	None	-	-	NT	
Defect: Vacuum fuel pressure regulator plugged	Tim	None	-	None	-	-	NT	
<u>1983 Toyota Starlet</u>								
	Tom	None	-	None	-	-	NT	
Defect: CTS short	Tim	None	-	None	-	-	NT	
<u>1983 Nissan Maxima</u>								
	Tom	None	-	Yes (see comment)	No	Yes	Yes	Visual.
Defect: TPS shorted	Tim	None	-	Yes (see comment 1)	No	No (see comment 2)	NT	(1) Std vac type. (2) 2000 RPM -- opens at part throttle.

TABLE 3-13 (cont'd)

## DIAGNOSIS OF EGR AND SECONDARY AIR IN EFI/3CL SYSTEMS

<u>Year/Make/Model/Sup</u>	<u>Mechanic</u>	<u>Diverter Valve</u>	<u>Check Valve</u>	<u>EGR Valve Working?</u>	<u>EGR at Idle?</u>	<u>EGR at Part Throttle</u>	<u>Cold Temp Vacuum Cutoff?</u>	<u>Comments</u>
<u>1984 Toyota Camry</u>								
	Tom	None	-	Yes (see comment)	No	Yes	Yes	Valve movement checked.
Defect: OXS disconnected	Tim	None	-	Yes	No	Yes	NT	
<u>1984 BMW 318</u>								
	Tom	None	-	None	-	-	NT	
Defect: #4 injector wire disconnected	Tim	None	-	None	-	-	NT	
<u>1983 Toyota Celica</u>								
	Tom	None	-	Yes (see comment)	No	Yes	Yes	Valve movement.
Defect: CTS disconnected	Tim	None	-	Yes	No	Yes	NT	
<u>1983 Volvo 244</u>								
	Tom	None	-	None	-	-	NT	
Defect: Vac. line to fuel press. line plugged	Tim	None	-	None	-	-	NT	

TABLE 3-14

## CLOSED LOOP SYSTEM CHECK FOR EFI/3CL SYSTEMS

<u>Year/Make/Model</u>	<u>Mechanic</u>	<u>Fast Idle RPM/HC/CO</u>	<u>Oxy Disconnect RPM/HC/CO</u>	<u>Oxy to Ground RPM/HC/CO</u>	<u>Oxy to +VE RPM/HC/CO</u>	<u>Closed Loop Working?</u>	<u>Did Air Pump Dump?</u>	<u>Comments</u>
<u>1983 Nissan Maxima</u>								
	Tom	1892/10/0	1129/190/7.3	1110/190/7.3	820/30/0	Yes	No	
Defect: Adjusted TPS	Tim	650/90/.02	1000/230/7	1000/230/7.0	850/60/.05	Yes	-	
<u>1983 Volvo 244</u>								
	Tom	1500/0/0	1500/20/.1	1500/20/.1	1000/0/0	Yes	None	
Defect: Vacuum fuel pressure regulator plugged	Tim	620/90/1.2	620/100/1.3	Pulse to 700/200/5.	620/80/.12 (see comment)	Yes	-	Reconnect: 600/80/.6.
<u>1983 Toyota Starlet</u>								
	Tom	1700/50/0	1900/420/6.0	1900/400/6.0	1100/100/.1	Yes	None	
Defect: CTS short	Tim	750/150/.6	750/150/.6	750/170/.7	750/170/.7	No	-	Instrument drift on all system checks.
<u>1983 Nissan Maxima</u>								
	Tom	1380/10/0	1400/10/0	1400/10/0	1200/10/0	Yes (see comment)	None	Speed drop -- no change in exhaust readings.
Defect: TPS shorted	Tim	1400/60/.03	1400/25/.025	No change	No change	No	See comment	At idle, system worked (800 RPM).



TABLE 3-14 (cont'd)  
CLOSED LOOP SYSTEM CHECK FOR EFI/3CL SYSTEMS

<u>Year/Make/Model</u>	<u>Mechanic</u>	<u>Fast Idle RPM/HC/CO</u>	<u>Oxy Disconnect RPM/HC/CO</u>	<u>Oxy to Ground RPM/HC/CO</u>	<u>Oxy to +VE RPM/HC/CO</u>	<u>Closed Loop Working?</u>	<u>Did Air Pump Dump?</u>	<u>Comments</u>
<u>1984 Toyota Camry</u>								
	Tom	NTC/0/.1	Rise/100/.4	Rise/100/.4	Drop/0/0	Yes	None	
Defect: OXS disconnected	Tim	1150/150/2.2	1150/140/3.0	No change	No change	No	-	Harness wire disconnected.
<u>1984 BMW 318</u>								
	Tom	1380/0/0	1420/100/1.0	1420/100/1.0	1030/0/0	Yes	None	
Defect: #4 injector wire disconnected	Tim	1250/20/.01	1400/100/.9	1400/100/.8	1000/40/.01	Yes	-	
<u>1983 Toyota Celica</u>								
	Tom	2000/.1/0	2100/190/6.0	2100/190/6.0	1800/0/0	Yes	No	
Defect: CTS disconnected	Tim	1500/70/0	1600/350/6	No change	1250/50/.01	Yes	-	
<u>1983 Volvo 244</u>								
	Tom	1200/40/.5	950/40/1.0	950/40/1.0	800/50/.2	Yes	No	
Defect: Vac. line to fuel press. line plugged	Tim	1100/100/.05	1200/110/3.0	1100/100/4.8	800/40/.08	Yes	-	

TABLE 3-15

## DEFECTS INTRODUCED AND IDENTIFIED IN EFI/3CL SYSTEMS

<u>Year/Make/Model</u>	<u>Mechanic</u>	<u>Additional Checks</u>	<u>Defects Identified</u>	<u>Defects Introduced</u>	<u>Comments</u>
<u>1983 Nissan Maxima</u>					
	Tom	TPS open: 1047/10/0 TPS shorted: 1120/200/5.5 Idle switch open: 1150/5/0	CTS shorted	Adjusted TPS (ran rich).	Second trip - cyl. head temp shorted.
	Tim		TPS out of adjustment.	CTS short.	
<u>1983 Volvo 244</u>					
	Tom	CTS open 2570/300/3.5 short 1500/20/0	Airflow wire shorted NTC/50/.8.	Vac. fuel pressure regulator plugged.	
	Tim	TPS - ok (see comment) CTS - ok; harness and connections - ok.	See comment.	Changed resistance from air flow meter from 250 $\Omega$ to 0 $\Omega$ . Increased CO from $\approx$ .5 to $\approx$ 1.0, HC at 100.	Defect in fuel pressure circuit -- restricted vacuum control line to pressure regulator.
<u>1983 Toyota Starlet</u>					
	Tom	CTS open 1150/0S CTS short 1750/190/.15	None.	CTS short.	
	Tim	CTS open 1100/50/.01	None.	None.	Defect not found under hot conditions as it does not influence emissions.

TABLE 3-15 (cont'd)  
 DEFECTS INTRODUCED AND IDENTIFIED IN EFI/3CL SYSTEMS

<u>Year/Make/Model</u>	<u>Mechanic</u>	<u>Additional Checks</u>	<u>Defects Identified</u>	<u>Defects Introduced</u>	<u>Comments</u>
<u>1983 Nissan Maxima</u>					
	Tom	CTS open 1600/400/10 CTS short 1520/0/0	EGR open.	TPS shorted (rich mixture).	
	Tim		TPS short.	Reroute EGR lines for full vac. at idle (see comment).	Tried to disconnect air temp sensor -- could not because integrated with throttle body.
<u>1984 Toyota Camry</u>					
	Tom	CTS open: no change CTS short: died TPS: too difficult to check Airflow sensor open: lean running.	TPS adjusted (rich).	OXS disconnected.	
	Tim	Checked coolant temp sensor - good; TPS - good.	OXS line to harness cut.	Adjusted TPS (rich) (2 notches on the plastic gear counter-clockwise).	

TABLE 3-15 (cont'd)  
 DEFECTS INTRODUCED AND IDENTIFIED IN EFI/3CL SYSTEMS

<u>Year/Make/Model</u>	<u>Mechanic</u>	<u>Additional Checks</u>	<u>Defects Identified</u>	<u>Defects Introduced</u>	<u>Comments</u>
<u>1984 BMW 318</u>					
	Tom	CTS open - no chg vac. fuel press open - no chg. (OXS compensates for pressure change.)	Air leak located in intake manifold (lean running).	#4 injector wire disconnected.	
	Tim		#4 injector wire cut.	Introduced vacuum leak into idle circuit.	Injector defect found from rough running.
<u>1983 Toyota Celica</u>					
	Tom	Fuel press. vac. line open: 2000/20/0 CTS open: 1500/OFF/OFF	Rich running. Air flow meter adjusted.	Disconnected CTS.	
	Tim		CTS disconnected.	Adjusted air flow meter to run rich.	
<u>1983 Volvo 244</u>					
	Tom	CTS 2200/3.5/250 short 1300/0/10 fuel press. line plug 1070/30/.7	Air mass meter shorted.	Vac. line to fuel press. line plugged.	
	Tim		Vac. line to fuel press. line plugged.	Shorted air mass meter wire.	

#### 4. MECHANICS COMMENTS ON THE DIAGNOSTIC PROCEDURE

After completion of the validation testing, both mechanics were asked to submit their own judgment of the strengths and weaknesses of the recommended diagnostic procedures and suggest improvements. The impressions are detailed below, and is provided in their own words with only minor editorial changes, as required, for clarification.

##### MECHANICS COMMENTS AND RECOMMENDATIONS

###### Secondary Air

The secondary air diagnostic procedure was thorough and seems to be a reasonable system for evaluating both air pumps and pulse air systems. On certain cars (General Motors transverse 4 cyl) the diverter valves were difficult to gain access to and checking them would be a complicated, time-consuming procedure.

Another possible problem area is that in using the equipment specified, secondary air problems may never show symptoms. One could check for airflow to a dual-bed converter or exhaust manifold, but air volume and actual effect could not be checked. Also, as it would be hard to know exactly when the diverter valve should be doing what. Most cars in the test ran so clean that disconnecting the secondary air systems showed little change in CO/HC.

###### EGR

EGR check was thorough and would give adequate information on EGR valve performance. One problem area is that some manufacturers have temperature controls, others, transmission controls, and some no vacuum controls at all. Lack of vacuum operation might lead to a question of what type

of control is being used, with no obvious solution. Also, measuring EGR's effect during actual driving is beyond the scope of this test. Check generally consisted of manually opening valve and checking effect, and checking valve for vacuum and operation.

#### Closed-loop System

Closed-loop system test generally went well with the following observations:

- Dwell meter checks were not dependable, particularly for CIS injection cars. Frequently no change in dwell was found even when it was apparent system was operative.\*
- Replacing the computer when dwell readings were suspect was financially prohibitive. Computers were generally \$200-\$400 and not returnable. The manufacturers' manuals say a good quality dwell meter should suffice, but we found that to be inaccurate.
- Certain systems showed unusual control functions that would be impossible to ascertain without some prior knowledge.

Renaults and Chryslers both either had to be in gear or had closed throttle switches that had to be switched on. Often the method used for producing fast idle during test would be to close switch and make closed-loop inoperative.

Some Ford models (big V-8's, Thunderbirds, and Lincolns) had a memory that would disconnect the closed-loop if a defect was introduced. It was necessary to disconnect the battery to erase memory after defect was repaired in order to make closed-loop work again.

---

\*EEA traced the dwell meter problem to the use of a low impedance dwell meter by one of the mechanics.

Some Hondas and Toyotas were required to be in gear and wheels turning at 25 mph (speedo switch) for closed-loop to work. The 1984 Corolla SR5 allowed the closed-loop to work only under special load situations. Honda and Toyota had different mixture control mechanisms than most vehicles. Toyota, in particular, used an air control for closed-loop operation. The closed-loop would only work when vacuum was sent to one small solenoid next to the mixture control solenoid. It will be necessary to list these exceptions, plus any others in the procedure, or computer failure will be diagnosed frequently.

Feedback carburetor controls procedure worked well on American cars. On CIS (Bosch K-Jetronic) cars it would also be possible for the warm up regulator to cause rich running which the closed-loop could not compensate for. This should be included in the recommended diagnostics.

This procedure for E.F.I. parallels most manufacturers' procedures for E.F.I. diagnosis and although it appears comprehensive, it can be terribly time-consuming. Many of the checks, such as T.P.S. or airflow sensor, could not be done without additional information such as wiring codes and resistance readings. Access to several of these parts was difficult, particularly the computers, as would be purchase and replacement. Again, replacing computers can be expensive and guessing is not very cost-effective.

Our experience with the E.F.I. systems outside this test (actual conditions) has been most troublesome. Tracing poor performance problems that are not tune-up related that cause high emissions are extremely difficult.

We found the internal diagnostic checks on GM cars to be inconsistent. Often we would get trouble codes that did not relate to the problem involved even after the computer's memory had been cleared. Clearing

the memory should be added to the procedure. MAP sensors should be added to the procedure as their failure causes severe rich running.

### CONCLUSION

We feel that the closed-loop systems as now designed are an excellent pollution control device. This test was very illuminating to both shops but had certain deficiencies. These were:

- The lack of actual failed parts could be a severe hinderance of the judgment of our work. It is hard to tell if the defects we induced are similar to actual occurrences in the field, making it difficult to determine whether the procedure will aid in diagnosis in some cases. We found the closed-loop check to be adequate. However, it is possible that the secondary air, EGR, and E.F.I. checks may not cover the actual symptoms encountered upon actual failure of a part.
- The variations in models of cars used in this test did not cover all possible makes/models. Even so, the number of peculiarities found was significant. Had the test mix been greater, a proportionately larger number of problems could be anticipated.
- Outside mechanics should have been used to test the procedure. As the test progressed, we became adept at finding the "sabotaged" problems. A mechanic unfamiliar with these problems and procedures would not have been influenced by our "behind the scenes" knowledge.

### Major Recommendation

Inasmuch as the closed-loop systems of the future will be E.F.I. oriented, a comprehensive and accurate testing procedure should be established. We are no better able to trace E.F.I. problems of intermittent nature now than prior to the inception of this test.



## 5. REVISED DIAGNOSTIC PROCEDURES

### 5.1 OVERVIEW OF REVISIONS

The vehicles tested during the validation provided a number of examples where the diagnostic procedures needed to be modified or revised. We have summarized the problems encountered during validation in Table 5-1. Based on these data, and the mechanics' comments on the test procedure, the following revisions to the recommended procedures were made:

- Secondary Air System - No major revisions were required as the diagnostics proved adequate. However, some minor wording changes that clarify when engine should be running or off is included to prevent any confusion. EEA also recommends that mechanics be instructed about the differences between a single-bed and a dual-bed catalyst system in their secondary system operation.
- EGR Systems - We have added the caution that in many cars, EGR is turned on only with vehicle in gear. Other minor wording changes to clarify engine operation during each check are included.
- Closed-Loop System - Mechanics have been cautioned about the existence of switches at the throttle that turn on the closed-loop, and are advised to try with the car in gear or on a dynamometer (if available). These cautions are to prevent closed-loop clamps at idle from defeating the diagnostic. Wording on the diagnostic charts have been modified so that the sequence of events - in case of no response from the closed-loop - becomes evident.
- Feedback Carburetors - This diagnostic chart was one of the most successful in its original form, and the only minor correction is the requirement to repeat the test with vehicle in gear or on a dynamometer, as described in the closed-loop system check.
- Bosch K-Jetronic System - Another diagnostic chart that was successful in its original form. However, as recommended by mechanics, the system behavior and the check for the thermo-sensor (used in warmup) is now added to the diagnostics.

TABLE 5-1  
SUMMARY OF PROBLEMS ENCOUNTERED

<u>Vehicle</u>	<u>Problem</u>	<u>Cause</u>	<u>Action Recommended</u>
Isuzu I-Mark	Difficult to check EGR and diverter valve	No access to either valve	Use vacuum check only for EGR. Use hand-held mirror for inspecting diverter valve.
Mitsubishi Tredia	No response to closed-loop check	Unable to determine	Check if any special procedure is required for turning on closed-loop.
Buick Regal	EGR not functioning during test at idle	Transmission must be in "drive" to turn EGR on	Modify diagnostic procedure to include check with transmission in drive
Chrysler New Yorker (2.6 Litre)	One piece TPS difficult to check	Access to connection limited	--
Nissan Sentra	"Spike" response when oxygen sensor harness is grounded	Computer probably recognizes disconnect of oxygen sensor	Modify diagnostic procedure to allow for "spike" response
All Chrysler 2.2 litre	No response to closed-loop check	Microswitch on throttle turns off closed-loop at idle	Modify diagnostic to specify performing closed-loop check with throttle opened using accelerator

TABLE 5-1 (cont'd)

<u>Vehicle</u>	<u>Problem</u>	<u>Cause</u>	<u>Action Recommended</u>
All closed-loop carburetted Toyotas	No response to closed-loop check at idle or in-gear	Unique air-bleed system that uses closed-loop only at load	Diagnostic inapplicable, must use manual.
Fuel-injected Ford (1984 and later)	System does not respond to repair	Computer memory must be reset after repair	Disconnect battery terminal and reconnect to erase memory
Ford LTD	No response to closed-loop check at idle	Vehicle must be in-gear for closed-loop turn on	As for Buick Regal
Renault Alliance	No response to closed-loop check at times	Intake air must be above 60°F for closed-loop turn on	Modify diagnostic procedure to ensure fully warmed up engine with "stove" in place
Nissan Maxima/ Toyota Starlet	Mechanic unable to identify problems with airflow sensor or manifold pressure sensor	No procedure in recommended diagnostics	Include check of these components in this diagnostic procedure
Electronically fuel-injected systems	Difficult to trace source of problem	No physical check possible of sensors	If sensor failure is suspected, either replace or check with service manual

- Electronically Fuel-Injected Systems - As derived from the validation procedure, checks for the manifold pressure sensor/airflow sensor and vacuum connectors to the manifold pressure sensor are included. Additional cautions are introduced to try check with car in gear, and to clear the "keep-alive" memory (whenever applicable) after repairs are made. EEA recognizes the difficulty with identifying the various sensors and the difficulty in checking them when harness connectors are complex, but no meaningful general system to decode the wiring diagram is possible.

## 5.2 DIAGNOSTIC PROCEDURES

The revised recommended procedures are fully described in Tables 5-2 through 5-7. The revisions will result in diagnostic applicable to most makes and models, but not to carburetted Toyotas and Hondas. There are also some obvious limitations in the generalized procedures as applied to all electronic fuel injection, as at some stage a detailed wiring diagram may be required.

The diagnostics requires that the systems must be checked in the following sequence:

- Secondary air system
- EGR system
- Fuel system
- Catalyst

TABLE 5-2  
SECONDARY AIR SYSTEMS WITH AIR PUMP

Ensure air pump is connected and belts are tight. Check for any obviously cracked or broken hoses before starting engine.

Performance Test

- (1) Dual-Bed Catalyst Systems - After car is warmed up, check for air supply to catalyst by removing the hose connecting diverter valve to catalyst when engine is running.

If Air Supply to Catalyst - System OK

If no Air Supply to Catalyst - Check for air and air supply from pump outlet to exhaust manifold

Caution - If air is being diverted to atmosphere or air cleaner, it may be because of "closed-loop" problems (see closed-loop check).

<u>Test Response</u>	<u>Probable Cause</u>	<u>Action</u>
No Air from Pump	Pump Failure Loose Drive belt Leaks in hose	Replace Pump. Tighten. Replace hose or hose fitting.
Air supply to exhaust manifold	Vacuum present at switch valve  Switch valve inoperative	Check vacuum hose routings. Check computer.*  Replace valve.
Air dumped to air cleaner/atmosphere	Diverter valve inoperative	Check computer.* Replace diverter valve.
Heat damage to hoses and air pump	Check valve inoperative	Replace check valve.
Backfire during deceleration	Diverter valve inoperative	Replace diverter valve.

---

\*See "closed-loop" system performance check.

TABLE 5-2  
SECONDARY AIR SYSTEMS WITH AIR PUMP  
(Continued)

- (2) Single-Bed Catalyst System - After car is warmed up, check for air supply to air cleaner or atmosphere with engine running.

Caution - If air pump is supplying air to exhaust manifold, it may be because of "closed-loop" problems (see closed-loop check)

<u>Test Response</u>	<u>Probable Cause</u>	<u>Action</u>
Air supply to exhaust manifold	Vacuum present at switch valve	Check vacuum hose routings. Check temperature sensor.*
No air from pump	Pump failure Loose drive belt Leaks in the hose or hose fittings	Replace pump. Tighten belts. Replace hose or hose fittings.
Heat damage to hoses and/or air pump	Check valve inoperative	Replace check valve.
Backfire during deceleration	Diverter valve inoperative	Replace diverter valve.

#### PULSE AIR SYSTEM

Performance Test - With engine running, check for hissing noise near pulse air valve. With engine off, see if rubber hose or air valve exhibits heat damage. Apply a vacuum to the rubber hose connecting pulse air valve to air cleaner. Valve should hold vacuum for two seconds. Replace valve if there are signs of heat damage or it does not hold vacuum for two seconds.

---

\*See closed-loop system check.

TABLE 5-3  
 DIAGNOSIS OF EGR SYSTEMS  
 (Backpressure and Ported Vacuum System)

System Performance Check: With engine off, place finger under EGR valve and push on diaphragm. EGR valve should move freely from open to close (or replace EGR valve). With vehicle in "Park" or "Neutral" and engine running, open throttle to increase engine rpm to 2000. EGR diaphragm should move up (valve open). With backpressure EGR, exhaust must be blocked partially to create enough backpressure for EGR to open. Close throttle on engine and EGR valve should close.

Caution - In some cars, EGR vacuum is turned on only when car is in gear.

<u>Test Response</u>	<u>Probable Cause</u>	<u>Action</u>
EGR valve does not open on system check	Vacuum hoses improperly connected or leaking	Check and replace hose.
	Defective EGR valve	Connect external vacuum to EGR valve. With engine at fast idle apply vacuum to valve. If valve does not open, replace.
Valve does not open on system check, opens with external vacuum	Place car in gear with brake on. Check for EGR valve movement	
	Defective thermal vacuum switch (TVS)*	Disconnect TVS and bypass it. If EGR valve opens, replace TVS.
	Defective control plugged vacuum passage	Check EGR vacuum at carburetor of manifold. Clean vacuum passages.

---

\*In some cars, the EGR vacuum is controlled by an electrical solenoid that is turned on by the computer. If solenoid is inoperative, replace or else check computer.

TABLE 5-3  
 DIAGNOSIS OF EGR SYSTEMS  
 (Backpressure and Ported Vacuum System)  
 (Continued)

<u>Test Response</u>	<u>Probable Cause</u>	<u>Action</u>
EGR valve open at idle	Vacuum control defective	Disconnect vacuum hose from valve. If valve closes, check carburetor for sticking throttle. If valve opens, replace EGR valve.
Engine rough at idle with EGR valve closed	High EGR leakage with valve closed	Remove EGR valve and inspect to ensure poppet is seated. Clean deposits, if necessary or replace.



TABLE 5-4

CLOSED-LOOP SYSTEM PERFORMANCE CHECK AND  
OXYGEN SENSOR CHECK

Common For All Closed-Loop Cars  
Except Carburetted Toyota and Honda Cars

1. Disconnect at harness connection at oxygen sensor.
2. Connect voltmeter (use high-impedance voltmeter) to oxygen sensor. Start car and warm-up at fast idle.
3. Touch oxygen sensor harness lead with one finger. Using the other hand, touch battery positive (+) terminal (engine in fast idle).
4. If system is okay:
  - Engine speed will decrease when touching battery + terminal. Speed decrease will be audible, in excess of 100 rpm.
  - Engine speed will increase if the harness lead is grounded (-). Speed increase will be audible, in excess of 100 rpm.

Caution - In many cars, closed-loop is turned on with a throttle switch (Chrysler cars) or in gear (Mitsubishi, Renault). If there is no response, try test with foot on brake or clutch, and vehicle in gear. Try test on dynamometer with vehicle in gear, if possible.

5. As engine speed increases and decreases voltmeter connected to oxygen sensor should read 0.5 to 1 volt when engine speed is high, 0 to 0.2 volts when engine speed is low. Disconnect air pump for dual-bed catalyst systems. If system is okay, no voltage on oxygen sensor, check CO reading with the harness lead grounded. If CO reading is higher (>2 percent), replace oxygen sensor. If CO reading is low, check for vacuum leaks, adjust idle mixture to specification and repeat test (idle mixture adjustment not applicable for EFI systems).
6. If system does not respond, go to appropriate detailed diagnostics depending on whether car has converter, Bosch EIS fuel injection or electronic fuel injection.

Note: If secondary air is being diverted to atmosphere on GM and Ford cars, this is an indicator that the closed-loop system is malfunctioning. However, no modification to the system performance check is required.

TABLE 5-5  
DIAGNOSTIC METHOD FOR FEEDBACK CARBURETORS

1. Connect dwell meter to carburetor solenoid.
2. Turn engine on. Carburetor solenoid should click audibly. Dwell meter should read a constant value of 18-30°.
3. Start car and warmup. Perform closed-loop system performance check. Dwell meter must read low when harness is grounded, high when finger is touching battery.

<u>Test Response</u>	<u>Probable Cause</u>	<u>Action</u>
No dwell meter reading	Loose connection to solenoid	Repair.
	Computer inoperative	Replace computer.
	Disconnected ground	Check ground lead and tightened.
No audible clicking (dwell okay)	Try with car in gear*	
	Carburetor solenoid inoperative	Clean solenoid, or replace.
Low dwell (< 30°) with finger touching battery	Loose connection in oxygen sensor wire	Check continuity and replace.
	Coolant Temperature sensor failed (open)	Check connections to sensor. Check resistance and replace sensor if open.**
	Computer inoperative	Replace computer.
	Throttle position sensor (TPS) inoperative	Check connections to TPS. Measure resistance of TPS with throttle closed and open. Replace TPS if resistance out of specification.

---

\*Use brake or clutch to prevent motion, or use dynamometer if available.

\*\*Use brake or clutch to prevent motion, or use dynamometer if available.

TABLE 5-5  
 DIAGNOSTIC METHOD FOR FEEDBACK CARBURETORS  
 (Continued)

<u>Test Response</u>	<u>Probable Cause</u>	<u>Action</u>
High dwell ( $>50^\circ$ ) with oxygen sensor connector grounded	Coolant Temperature sensor failed (short)	Check connections. Check sensor resistance and replace if shorted.
	Computer inoperative	Replace computer.

TABLE 5-6  
DIAGNOSTIC METHOD FOR BOSCH K-JETRONIC FUEL SYSTEM

1. Connect dwell meter (high-impedance)\* to frequency valve input or to test socket, if available.
2. Turn ignition on. Frequency valve must click audibly. Dwell (on 4-cylinder scale) must be about 60°.
3. Perform closed-loop system performance test. Dwell meter must go from 90° when harness is grounded to less than 50° when finger is touching battery.
4. If system performance check fails and engine is running lean (i.e., rough idle) check for vacuum leaks or clogged injectors.

<u>Test Response</u>	<u>Probable Cause</u>	<u>Action</u>
No audible clicking (dwell meter reads 60°)	Frequency valve inoperative	Replace frequency valve.
No dwell meter reading	Frequency valve failed	Check resistance. If lower than 3 ohms, replace.
	No connection between computer valve	Check harness for continuity.
	Bad computer	Replace computer.
	Disconnected ground	Check ground lead and tighten.
System performance check fails (no change in speed)	Bad connection in wiring harness for oxygen sensor connection	Check continuity, replace wire or connector
	Computer inoperative	Replace computer.
	Air flow sensor damaged or incorrectly set	Set idle adjustment in air flow sensor, repair if necessary.
System performance check OK, CO high	Memo-Sensor for cold start warmup fails	Check and replace as necessary.

---

\*Caution: Low impedance dwell meters may not provide any response.

TABLE 5-7

DIAGNOSTIC METHOD FOR ELECTRONICALLY FUEL-INJECTED SYSTEMS

Note: These tests are applicable to all electronically fuel-injected systems.

1. Disconnect air pump by removing hose connection (if applicable). Insert CO probe in tailpipe. Proceed as in system performance test. Try with car in gear if system performance check fails in neutral.
2. If engine is running rough at idle, check for vacuum leaks.
3. Ground sensor harness. Engine should speed up from fast idle.

<u>Test Response</u>	<u>Probable Cause</u>	<u>Action</u>
No engine response CO very high (3 percent)	Manifold Pressure Sensor (MPS) or Air Flow Sensor (AFS)	Check if vacuum hose is connected to MPS. Check for open or short in MPS or AFS.
No engine response CO high	Coolant Temperature Sensor (CTS)	Check if sensor is shorted or open at harness. Replace if necessary.
	Throttle Position Sensor (TPS)	Check movement of sensor. Check if sensor is shorted or open and replace.
	Harness	Check connections to CTS, TPS, and injectors. Repair as necessary.
	Computer Air Flow Sensor (if applicable)	Check for Idle adjustment.

TABLE 5-7  
 DIAGNOSTIC METHOD FOR ELECTRONICALLY FUEL-INJECTED SYSTEMS  
 (Continued)

<u>Test Response</u>	<u>Probable Cause</u>	<u>Action</u>
No engine response CO low	Fuel pressure	Check if fuel pressure regulator is damaged. Check if fuel pressure from pump is at specification.
	Injectors	Check injector spray. Clean or replace as necessary.
	Repeat checks for high CO case.	
Engine responds CO high	Fuel Pressure	As above.
	Injectors	As above.

## 6. CATALYST DIAGNOSTICS

### 6.1 OVERVIEW

Although the diagnostics of secondary air, EGR and the fuel system were developed under Phase I of this study, it was not possible to develop adequate diagnostics for catalysts. However, based on theoretical principles, we developed two checks that could be potentially useful in diagnosing failed catalysts. They are:

- Disconnecting a spark plug and checking (with engine running at fast idle) the tailpipe HC emissions. We had postulated, based on a small sample, that a good catalyst could have tailpipe emissions of less than 1,000 ppm HC whereas a bad catalyst could exceed 1,500 ppm HC, while tailpipe readings in between 1,000 and 1,500 ppm would signify a partially deteriorated catalyst.
- Removing the oxygen sensor and checking HC emissions before and after the catalyst, by inserting the emissions probe through the oxygen sensor part. This test was to be conducted at fast idle.

At the request of the ARB, we added a third check, which was to measure the temperature of the exhaust pipe before and after the catalyst.

Due to funding limitations, only a small number of cars could be tested. A major problem encountered was in obtaining catalysts that were definitely damaged or poisoned. We obtained used catalysts that, in many instances, appeared partially clogged probably as a result of poisoning. Additionally, these catalysts were doused with leaded gasoline and lit off, to ensure that thermal damage and lead poisoning occurred. To prevent any unburnt remaining gasoline from giving spurious emission readings, vehicles were driven with the 'bad' catalysts until idle emissions were relatively stable and showed no further signs of decrease. These catalysts were contrasted with the 'as received' catalysts on the

rented cars to provide a measure of emission characteristics of 'good' vs. 'bad' catalysts. All of the vehicles tested were relatively new, except for the Volvo 244, which had approximately 50,000 miles on the odometer.

## 6.2 RESULTS OF TESTING

A total of 12 cars were tested, and included a wide variety of vehicles - European, Japanese and domestic - featuring all types of fuel systems. Due to difficulty in obtaining dual-bed catalysts that were malfunctioning or disabled, we had to limit the number of dual-bed vehicles tested to two. However, as described below, the method recommended for checking catalysts makes it immaterial if the catalyst is single-bed or dual-bed.

As a precondition to all catalyst checks, it is required that the engine emission control components not be malfunctioning. This is necessary because three-way catalysts operate only when the closed-loop system is functioning. If the exhaust gas mixture is very rich, then even a operational catalyst will be unable to oxidize the HC and CO emissions. Thus, all tests were conducted on vehicles with no additional malperformances present. A few preliminary tests revealed:

- With the engine operating properly, engine-out emissions are typically very low at idle or fast idle.
- Vehicle utilizing secondary air have engine-out and tailpipe emissions that are at the measurement threshold. Additionally, the secondary air cools the exhaust so much that temperature readings are nearly constant across the catalyst.

As a result, it was decided to test all vehicles with: 1) secondary air disconnected or dumped, whenever applicable and, 2) one spark plug disconnected to increase engine-out unburnt HC. The results of the tests are summarized in Table 6-1.



TABLE 6-1  
CATALYST DIAGNOSTICS

Model		As Received		With One Spark Plug Disconnected						
		HC/CO Check		HC/CO Check			Temperature Check			
		Good Catalyst	Pre-Catalyst	Good Catalyst	Bad Catalyst	Pre-Catalyst	Good Catalyst		Bad Catalyst	
							In	Out	In	Out
1984 Chevrolet Citation	HC	50	100	200	OS	OS	310	207	320	200
	CO	.6	.6	.7	2.6	2.6				
1984 VW Rabbit	HC	30	30	400	1900	1500	230	425	225	220
	CO	0	.6	1.8	1.2	1.1				
1984 Mitsubishi Tredia	HC	10	100	400	1100	1100	205	280	210	210
	CO	0	.1	.1	.05	.05				
1983 Pontiac Grand Prix (6c1)*	HC	0	110	200	200	OS	255	337	260	300
	CO	0	0	0	0	.5				
1984 Toyota Camry	HC	0	10	400	OS	OS	360	490	330	365
	CO	.1	.1	.6	.7	.7				
1983 Buick Skylark	HC	20	20	600	OS	OS	178	310	172	112
	CO	1.3	.3	.1	.3	.3				
1983 BMW 320i	HC	70	70	400	OS	OS	220	310	215	230
	CO	.6	.6	.6	.5	.6				
1984 Nissan Sentra	HC	0	0	900	OS	OS	350	420	340	350
	CO	.1	.6	.6	.8	.8				

\*Air pump not dumped.

OS = off scale.

TABLE 6-1  
 CATALYST DIAGNOSTICS (cont'd)

<u>Model</u>	<u>As Received</u>			<u>With One Spark Plug Disconnected</u>						
	<u>HC/CO Check</u>			<u>HC/CO Check</u>				<u>Temperature Check</u>		
		<u>Good Catalyst</u>	<u>Pre-Catalyst</u>	<u>Good Catalyst</u>	<u>Bad Catalyst</u>	<u>Pre-Catalyst</u>	<u>Good Catalyst</u>		<u>Bad Catalyst</u>	
		<u>In</u>	<u>Out</u>				<u>In</u>	<u>Out</u>	<u>In</u>	<u>Out</u>
1981 Volvo 244*	HC	170	200	1150	OS	OS	305	630	310	310
	CO	.6	1.0	.4	.4	.4				
1982 VW Rabbit	HC	70	70	400	1800	OS	310	420	310	340
	CO	.4	.4	.5	.8	.5				
1983 VW Jetta	HC	110	135	1000	OS	OS	270	345	256	178
	CO	.2	.2	1.2	2.5	2.5				
1984 Pontiac Bonneville (6c1)	HC	10	50	100**	OS	1500	400	485	390	400
	CO	0.1	0.1	0.2**	0.2	0.1				

\*Car had over 40,000 miles on odometer.

\*\*Secondary air dumped.

OS = off scale.

As can be seen, the first test that measured HC and CO at the tailpipe only, shows that in every case except one (the Volvo 244), HC emissions with a good catalyst were consistently below 1,000 ppm. The Volvo 244, a vehicle with nearly 50,000 miles of use, was the only one to show emissions of over 1,000 ppm with the as received (or 'good') catalyst, and EEA suspects that the catalyst was partially deteriorated. With the 'bad' catalyst, HC emissions were usually off-scale (over 2,000 ppm). Note that one car was tested with secondary air, and the influence of secondary air was so pervasive that emissions were unaffected by the catalyst. In another case, in the Mitsubishi Tredia - the 'bad' catalyst yielded HC emissions of only 1,100 ppm, and EEA suspects that the pulse-air system was not correctly sealed, as engine-out emissions (as measured through the oxygen sensor port) at fast idle was only 1,100 ppm.

The second test involved disconnecting the oxygen sensor, removing it from the exhaust port and placing the emission probe through the port to sample exhaust. As stated, the test was conducted at fast idle with no secondary air and one spark plug disconnected. In all cases, the 'pre-catalyst' HC emission reading was substantially higher (by a factor of at least 3) than the tailpipe reading with a good catalyst, but not with a bad catalyst. In some cases the tailpipe reading with a bad catalyst is shown to be higher than the pre-catalyst reading in Table 6-1. This was because the value for pre-catalyst emissions shown were taken with the 'good' catalyst in place, but engine out emissions sometimes increased with the 'bad' catalyst because of the increased back pressure.

The 'pre-catalyst' emissions test with the oxygen sensor removed proved difficult to conduct in several cases because of the tight clearance between various engine components or the firewall and the oxygen sensor. Mechanics stated that an emissions probe with a tip shaped like the oxygen sensor that could be directly screwed into the port would be a great help in performing the test.

The final test involving measuring pre- and after-catalyst temperature measurements. The catalyst itself is thermally insulated and the measurements were required to be done on the exhaust pipe close to the catalyst. Since there is some rust on the pipe, the thermocouples were mounted on the exhaust pipe after rust had been ground off, exposing bare metal. The temperature check was very successful in all cars except one. When successful, the 'good' catalyst recorded temperature increases of 75°F or more (typically 100°F). Bad catalysts, however, recorded temperature increases of 0-30°F. In one case, however, a temperature decrease was recorded for both 'good' and 'bad' catalysts. We later found that this was because the exhaust pipe to the catalyst was double-walled to conserve heat; this presents a problem for which there is no easy solution.

### 6.3 CONCLUSIONS

Catalyst tests can be conducted only if the rest of the emission control components are operating properly. If tests are conducted at idle, it is required to:

- Disable any secondary air to the exhaust.
- Disconnect one spark plug, and wait for about one minute until exhaust emissions are stable.
- Temperature difference defined as catalyst out-catalyst in temperature.

The following checks are then possible:

- 1) Measure tailpipe HC. If readings are less than 1,000 ppm, catalyst is okay. If readings are in excess of 1,500 ppm, catalyst is damaged. Catalyst is partially damaged between 1,000 and 1,500 ppm. (This test assumes that with all spark plugs connected, tailpipe HC should not exceed emission warranty requirements with a good catalyst, i.e., engine-out HC is normal.) This test is the easiest to conduct.

- 2) Disconnect oxygen sensor and remove. Insert emission probe through oxygen sensor port and measure 'pre-catalyst' HC. If pre-catalyst HC is greater than tailpipe HC by a factor of three or more, catalyst is good. Catalyst is bad if the pre-catalyst HC is equal to the tailpipe HC, and partially damaged if readings are between those specified for 'good' and 'bad'. This test does not require the assumption of low engine-out HC emissions, but access to the oxygen sensor port is difficult, and the test is time consuming.
- 3) Grind rust off exhaust pipe immediately before and after the catalyst. If temperature differential (catalyst out -catalyst in) is positive and over 75°F, catalyst is good. If below 25°F or negative, catalyst is bad, and partially damaged if between the two. This test, however, will not work if the exhaust pipe is double-walled. The test is also time consuming to conduct, and may be difficult to perform at cold ambient temperatures.

Manufacturers -- especially GM and Ford -- have expressed concerns about catalyst damage due to overheating if the vehicle is operated with one spark plug not working. Earlier tests conducted with one spark plug disconnected did not require disablement of secondary air. EEA believes that much of the manufacturers concerns should be alleviated by requiring disconnection of secondary air. (This removes the source of excess oxygen that can lead to high temperatures in the catalyst.) As an added caution, EEA suggests that the engine be operated only at no load conditions for no longer than 5 minutes with one spark plug disconnected.



APPENDIX A  
FORM USED BY MECHANICS FOR REPORT DATA

CAR - MAKE/MODEL/YEAR

- |    |                  |                 |           |               |      |
|----|------------------|-----------------|-----------|---------------|------|
| 1) | Emission Control | CARB            | TBI       | EFI           | MFI  |
|    | (Circle)         | Air Pump        | Pulse Air | None          |      |
|    |                  | Back Pressure   | EGR       | Ported EGR    | None |
|    |                  | Single Catalyst |           | Dual Catalyst |      |

2) Secondary Air Check (Describe)

- Air Pump/Pulse Air
- Diverter Valve
- Check Valve

3) EGR Check (Describe)

Valve working?

EGR at idle?

EGR at part throttle?

Cold temp Vac cutoff?

4) System Performance Check

- |                          |                              |     |    |    |
|--------------------------|------------------------------|-----|----|----|
|                          |                              | RPM | HC | CO |
| <input type="checkbox"/> | Fast Idle (as is)            |     |    |    |
| <input type="checkbox"/> | Oxy Sensor Disconnect        |     |    |    |
| <input type="checkbox"/> | Oxy Sensor Harness to Ground |     |    |    |
| <input type="checkbox"/> | Oxy Sensor or harness to +VE |     |    |    |

Closed Loop Working? (yes or no)

Did Air Pump Dump During Check? (yes or no)

When?



5) Describe Next Checks (include RPM, HC, CO) in sequence.

6) Defect(s) Identified (note if corrected.

7) Defect(s) Introduced



APPENDIX B  
LIST OF ABBREVIATIONS

*	Missing data
CARB	Carburetor
CL	Closed-loop
CTS	Coolant temperature sensor
Cat.	Catalyst
Div.	Diverter valve
EGR	Exhaust gas recirculation
EFI	Electronic fuel injection
Exh.	Exhaust
MCS	Mixture control solenoid
MFI	Mechanical fuel injection
MPS	Manifold pressure sensor
NT	Not tested
NTC	No tach connection
OS	Off scale
OXS	Oxygen sensor
PLS	Pulse air
PMP	Air pump
TBI	Throttle-body fuel injection
TPS	Throttle position sensor
Vac.	Vacuum

