



**California Low Carbon Fuel Standard §95489(c):
Application for LCFS Credits for
Producing and Transporting Crudes Using Innovative Methods**

Cahn Solar Plant

Site Location:
Chevron's Lost Hills Oil Field
SE SE SEC 4 27 21
Lost Hills, CA 93249



March 2020

Executive Summary

Chevron U.S.A. Inc. has contracted with SunPower Corporation to design and build a 29MW_{AC} solar photovoltaic plant on approximately 220 acres of Chevron's land adjacent to Chevron's Lost Hills oil field in Kern County, California. Construction is near completion with an expected commercial operation date in March 2020. The plant design is also planned to incorporate lithium ion batteries with a 20 megawatt-hour (MWh) capacity that will be DC-coupled with the solar inverters. The addition of the battery storage component is currently undergoing a System Impact Study by PG&E and is expected to be constructed and online during the fourth quarter of 2020.

Chevron will purchase all the output of the Solar Plant under a Power Purchase Agreement. The purchased electricity will partially displace the energy currently consumed from Pacific Gas & Electric with renewable solar energy generated on-site to be used by the oilfield operations. Solar energy generated in excess of Chevron's real-time demand will be exported to Pacific Gas & Electric according to California's Net Energy Metering 2.0 program. The battery modules will store energy generated by the solar arrays during peak solar output, reducing the excess power exported to the grid, and will dispatch it later when solar output is lower for consumption by the oil field.

As described further in this application, Chevron estimates that approximately 38,700 MWh of solar electricity from the PV Plant will displace field power on an annual basis, resulting in 19,800 metric tons of LCFS credits being generated.

After the battery plant is commissioned, an additional 5,300 MWh per year of solar energy will be stored in batteries that will also be consumed by oil field operations. This results in an additional 2,700 metric tons of LCFS credits, for a total of 22,500 metric tons when battery storage capability is fully functional.

Table of Contents

1. Project Description
2. Net Energy Metering
3. Electrical Diagrams
4. Maps and Project Location
5. Estimate of LCFS Credits
6. Battery Storage and Estimated Additional Credits
7. Opt-in Producer
8. Confidential Business Information

List of Appendices

Appendix A: Electrical Diagrams

Appendix B: Maps

Appendix C: Credit Calculations

Appendix D: Estimated Power Generation

Appendix E: Refining of Lost Hills Oil

Appendix F: Sample Calculations Using Proposed Metering Approach

Appendix G: Recordkeeping and Reporting Plan

1. Project Description

Chevron operates a portion of the Lost Hills oil field in Kern County, California located near the intersection of Interstate 5 and State Highway 46. Historically Chevron has purchased electricity for use in the field from Pacific Gas & Electric (PG&E). This LCFS application is for a solar electricity and energy storage plant (“Solar Plant”) under construction at Lost Hills that will partially displace the energy consumed from PG&E with renewable solar energy generated on-site to be used by the oilfield operations. The Solar Plant consists of several arrays of photovoltaic (“PV”) panels, inverters and a substation with transformers to step up power voltage to 70kV for export to Chevron. The design is also planned to incorporate lithium ion batteries that will be DC-coupled with the solar inverters.

SunPower Corporation designed and is constructing the Solar Plant. The PV panels used are SunPower P-series modules that are composed of mono-crystalline Silicon cells, assembled in an efficient shingled design and protected by SunPower’s specially engineered encapsulant. The project incorporates a single-axis tracking system to optimize power production. Ten inverters manufactured by Power Electronics will convert DC power to AC. The battery modules will store energy generated by the solar arrays during peak solar output, reducing the excess power exported to the grid, and will dispatch it later when solar output is lower for consumption by the oil field.

The Solar Plant is designed to produce a maximum of 29MW_{AC} (megawatts of alternating current) with an estimated initial annual production of approximately 75,000 megawatt-hours (MWh). Output of the PV panels is expected to degrade by approximately 0.5% per year. The battery storage component will have 20 MWh of capacity. Battery capacity is expected to degrade by approximately 2.5% per year. The PV panels, inverters, and sub-station are under construction with a planned commercial operation date during March 2020. The addition of the battery storage component is currently undergoing a System Impact Study by PG&E and is expected to be constructed and online during the fourth quarter of 2020.

The Solar Plant is owned by Solar Star Lost Hills, LLC (“Solar Star”) on approximately 220 acres of Chevron-owned land adjacent to the Lost Hills oil field. Chevron will purchase all of the output of the Solar Plant under a Power Purchase Agreement. Energy that Chevron purchases from Solar Star will be used to power oil production and fluid handling facilities in the Lost Hills oil field with a de minimis amount consumed in the oil field control room and field office. Solar energy generated in excess of Chevron’s real-time demand will be exported to PG&E according to California’s Net Energy Metering 2.0 program (see the following section for additional description).

The Solar Plant will be intertied solely to Chevron’s 70kV sub-station. Solar energy generated by Solar Star will be metered at the solar site boundary by a Schweitzer Engineering Laboratories Model SEL-735 power and revenue quality meter.

Chevron’s sub-station contains step-down transformers to 12kV and interconnects to Chevron’s proprietary electricity distribution system in the Lost Hills oil field. Chevron’s sub-station also incorporates a bi-directional meter that will measure export of excess solar energy to the PG&E grid and imports of grid electricity used by Chevron when solar energy production is not adequate to meet Chevron’s demand.

This meter is also a Schweitzer Engineering Laboratories Model SEL-735, a power and revenue quality meter.¹

Both meters described above are custody-transfer quality that will exceed ANSI C12.20-2015 0.1 and IEC 62053-22:2003 0.2 accuracy class requirements and will be routinely re-calibrated to ensure they continue to operate within their accuracy. Meter readings will be logged and archived by Chevron. Records will be kept by Chevron and available upon request pursuant to § 95489(c)(4) of the LCFS regulation.

The graph below depicts the estimated solar generation output on an average summer day split between the power consumed directly in the oil field and the excess power exported to the grid.

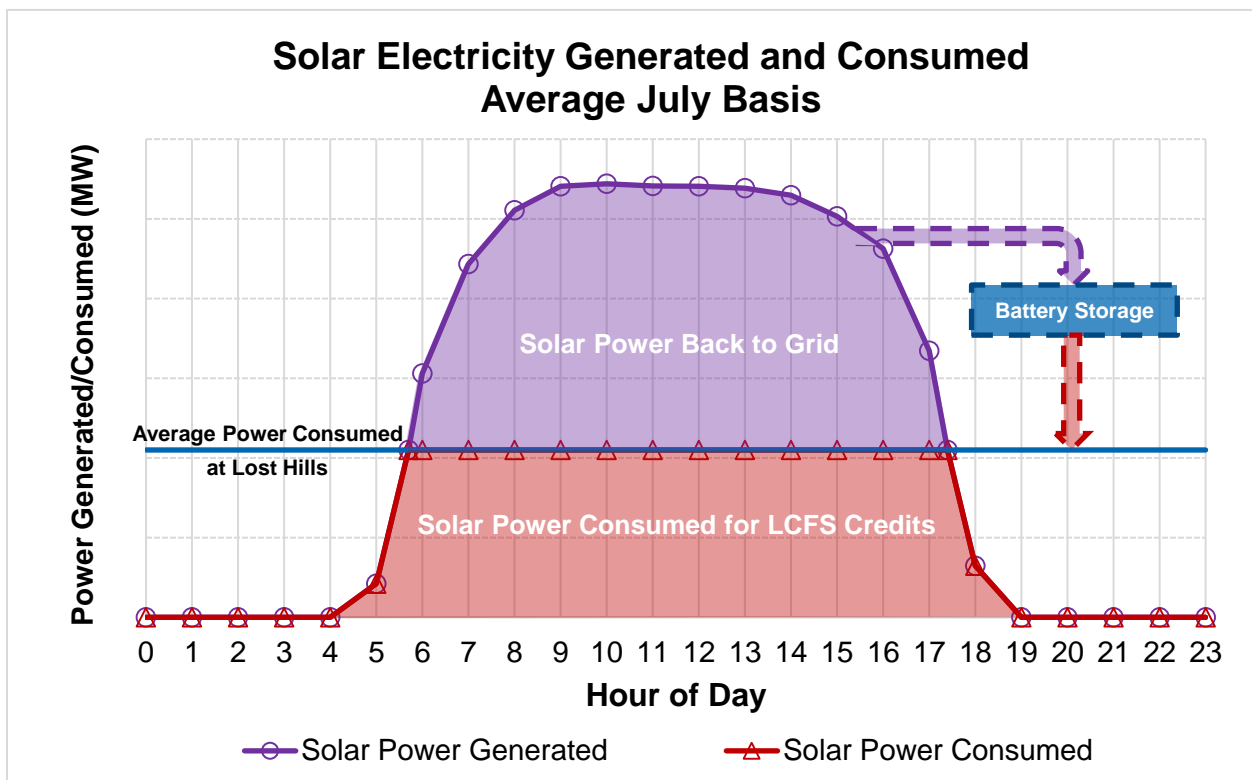

2. Net Energy Metering

Net Energy Metering (NEM) initially began in California in 1996 to encourage private investment in renewable energy. NEM is a billing system that credits an electricity customer that installs and operates a renewable energy facility for the excess electricity produced that is sent to the electric grid. Since its initial adoption, NEM policy has been modified and expanded several times by state legislative action and decisions of the California Public Utilities Commission (CPUC).

¹See https://static.selinc.com/assets/Literature/Product%20Literature/Flyers/735_PF00261.pdf?v=20191007-152325 for the general specifications for this meter.

In January 2016, the CPUC enacted a significant revision to NEM policy called NEM 2.0. One important change enacted under NEM 2.0 was the removal of the 1MW facility size limit which now allows for larger facilities such as the Lost Hills Solar Plant to operate under the provisions of NEM. NEM 2.0 also requires that customers with solar generation equipment be charged using Time of Use rates.

Historically Chevron has purchased electricity from PG&E at the Lost Hills oil field under the E20 industrial tariff. The E20 tariff contains three primary charges: energy, demand and non-bypassable charges. After the Solar Plant goes online, Chevron will continue to pay demand charges for use of the grid and non-bypassable charges on the full amount of electricity consumed from the grid.

However, the energy portion of Chevron’s bill will be eligible for net energy metering. Solar energy generated in excess of Chevron’s demand will be exported to PG&E and valued at the time of use price in effect at the time of export. The value of exported power will be netted against the cost of the energy that Chevron imports from PG&E during hours that solar is not producing. Imported power will also be valued at the time of use price in effect at the time of import.

Confidential business information has been redacted by the applicant.

The drawing at the right shows Chevron’s metering plan. Net Meter “A” is the bi-directional meter located at Chevron’s sub-station that measures the export of excess solar to PG&E and the import of PG&E power when the solar array power generation does not fully meet oil field demand. PV Meter “B,” connected to Chevron’s sub-station and under Solar Star’s operational control, will measure the power generated and supplied by the Solar Plant (direct solar from the PV system and stored battery power).

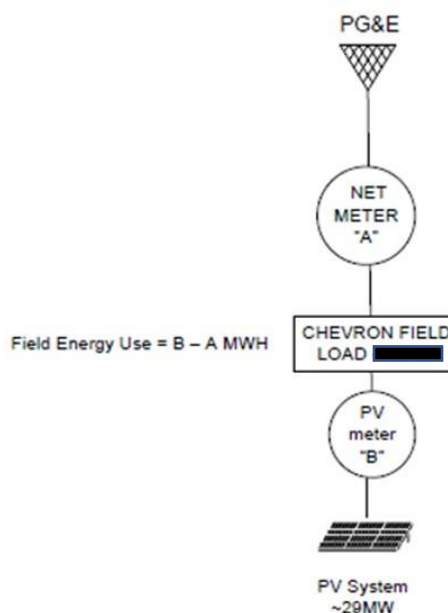

Solar power generated will first flow to the oil field with excess energy exported to PG&E being measured at Meter “A”. During hours that solar generation exceeds oil field demand, solar power consumed by the oil field will be measured as Meter “B” minus Meter “A”. During hours that solar generation is less than oil field demand, solar power consumed at the oil field will be measured as the output of Meter “B”.

The function of Meters “A” and “B” will remain the same after battery storage is commissioned at the Solar Plant. The only difference will be an increase in the measured quantity of electricity consumed by the oil field during the late afternoon/early evening and a decrease in the excess energy exported to the grid during daytime.

The table below shows sample calculations for the two cases described above as well as an evening case when no solar power is being generated. For a typical mid-day, peak generation case, the amount of

electricity measured at Meter B exceeds oil field demand and electricity is exported as measured at Meter A; the difference in meter readings reflects the oilfield demand. The second case in the table represents late afternoon when oil field demand exceeds the solar supply and additional make-up power is drawn from the PG&E network. The third case in the table shows an evening case when oil field demand is completely met by power from the PG&E network.

Examples: (Units are MW generation for one hour)	PV Solar Meter B (MW Out)	Net Meter A (MW In)	Net Meter A (MW Out)	Solar Power Used in Field (Meter B – Meter A Out)	Total Oil Field Demand
Mid-day (peak generation)	29	0			
Late afternoon	5		0	5	
Evening	0		0	0	

Confidential business information has been redacted by the applicant.

3. Electrical Diagrams

Please refer to Appendix A for the one-line diagrams that depict the major components of the Solar Plant and the interconnection to Chevron’s sub-station.

4. Maps and Project Location

Please refer to Appendix B for maps that show the location of the Solar Project. GPS coordinates are approximately at Latitude 35.606300 North and Longitude 119.68985 West. The project covers approximately 220 acres of land. The oil field is adjacent to the west side of the Solar Plant.

5. Estimate of LCFS Credits

As described above, the solar array at Lost Hills generates more power than required by the field during the day, and excess power generated is exported to the grid according to the Net Energy Metering 2.0 program. Once battery storage capability comes on-line, a portion of the excess power will be stored for later use in the field. This is an important consideration, as only electricity consumed on-site is eligible for Innovative Crude credits (see § 95489(c)(1)(A)(3) of the LCFS regulation).

An estimate of field power displaced directly by solar electricity for a typical meteorological year was based on detailed modeling performed by SunPower that assessed power consumed by the field and power generated by the solar array on an hourly basis for a complete year. If solar power generated during an hour was less than power consumed by the field, that entire amount was assigned to the LCFS program. If solar power was greater than the power consumed by the field during an hour, only the amount up to field consumption was assigned to the LCFS program, with the remainder being exported to the grid or stored on-site in batteries for later use.

As described in Appendix C, we estimate that approximately 38,700 MWh of solar electricity will displace field power on an annual basis, resulting in 19,800 metric tons of LCFS credits being generated. Because

the emission reduction exceeds the threshold of 5,000 metric tons as required by § 95489(c)(1)(E), this project qualifies for LCFS credits under the Innovative Crude provisions of the regulations.

6. Battery Storage and Estimated Additional Credits

Appendix C also presents an estimate of the additional LCFS credits associated with battery storage and subsequent consumption of that power by the oil field. On an annual basis, the combined solar power (direct solar plus battery consumption) used by the Lost Hills field is estimated to be approximately 44,000 MWh, which represents 5,300 MWh of power associated with battery storage. This results in an additional 2,700 metric tons of LCFS credits, for a total of 22,500 metric tons when battery storage capability is fully functional.

7. Opt-in Producer

Chevron is the applicant for the LCFS credits under the Innovative method for crude oil production using solar electricity that will be generated by the solar plant developed and constructed by SunPower. According to the Power Purchase Agreement with Solar Star, Chevron will retain ownership of all environmental attributes of the project including any LCFS credits or Renewable Energy Credits (RECs).

Per § 95489 (c)(1)(D) of the LCFS regulation, Chevron will be the opt-in producer and will generate the Innovative Crude credits.

8. Confidential Business Information

The following information provided with this application is identified as confidential business information:

- Information related to the electrical demand for the Lost Hills oil field.
- Information in Appendix E which relates to the sale of crude to third parties, subsequent means of transport for oil deliveries to California refineries, and the specific refineries to which crude is delivered.
- Detailed electrical use for the Lost Hills oil field contained in the example calculations shown in Appendix F.

Appendix A: Electrical Diagrams

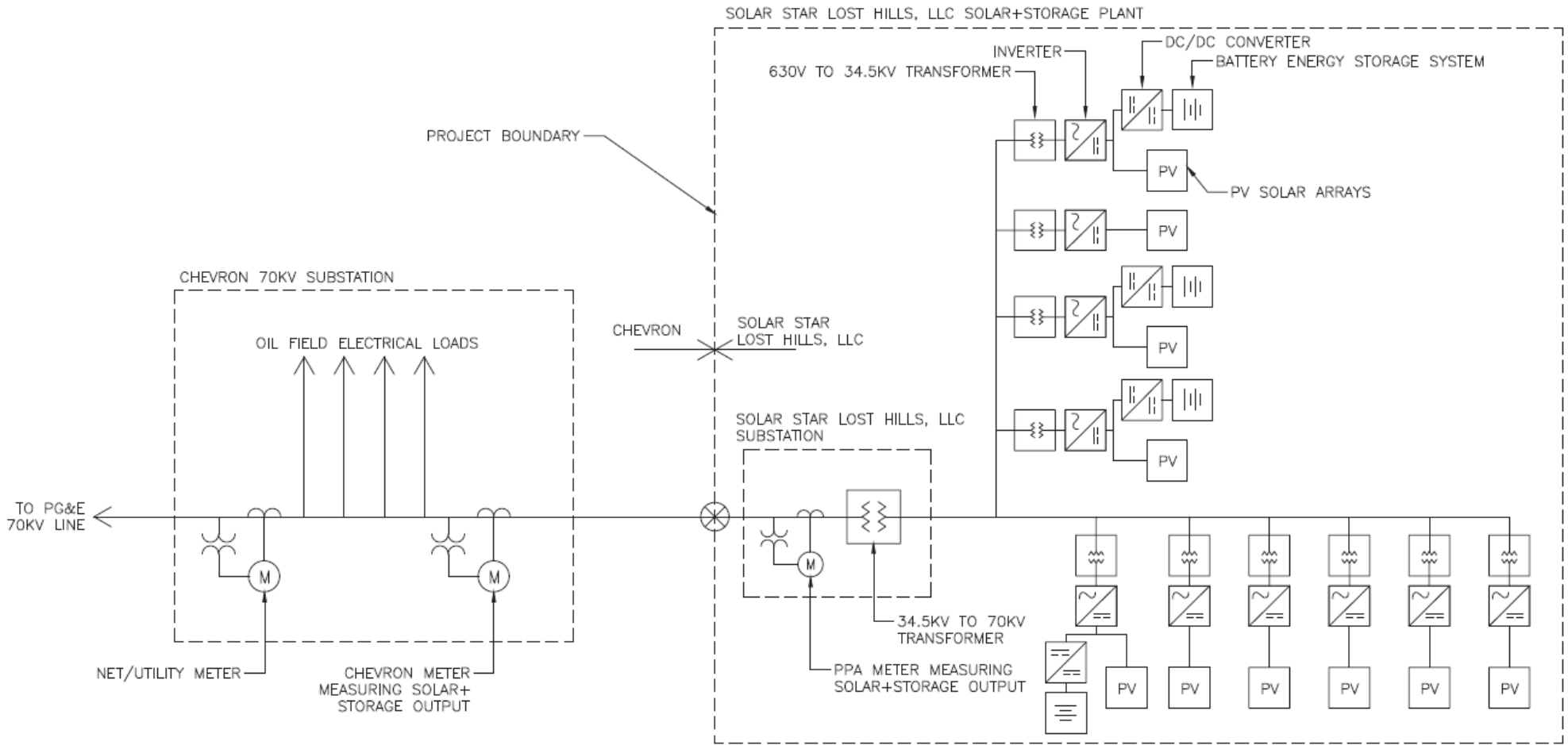

Appendix B: Maps

Project Location – Near the town of Lost Hills, California



Project Location – One hour north of Bakersfield at State Highway 46

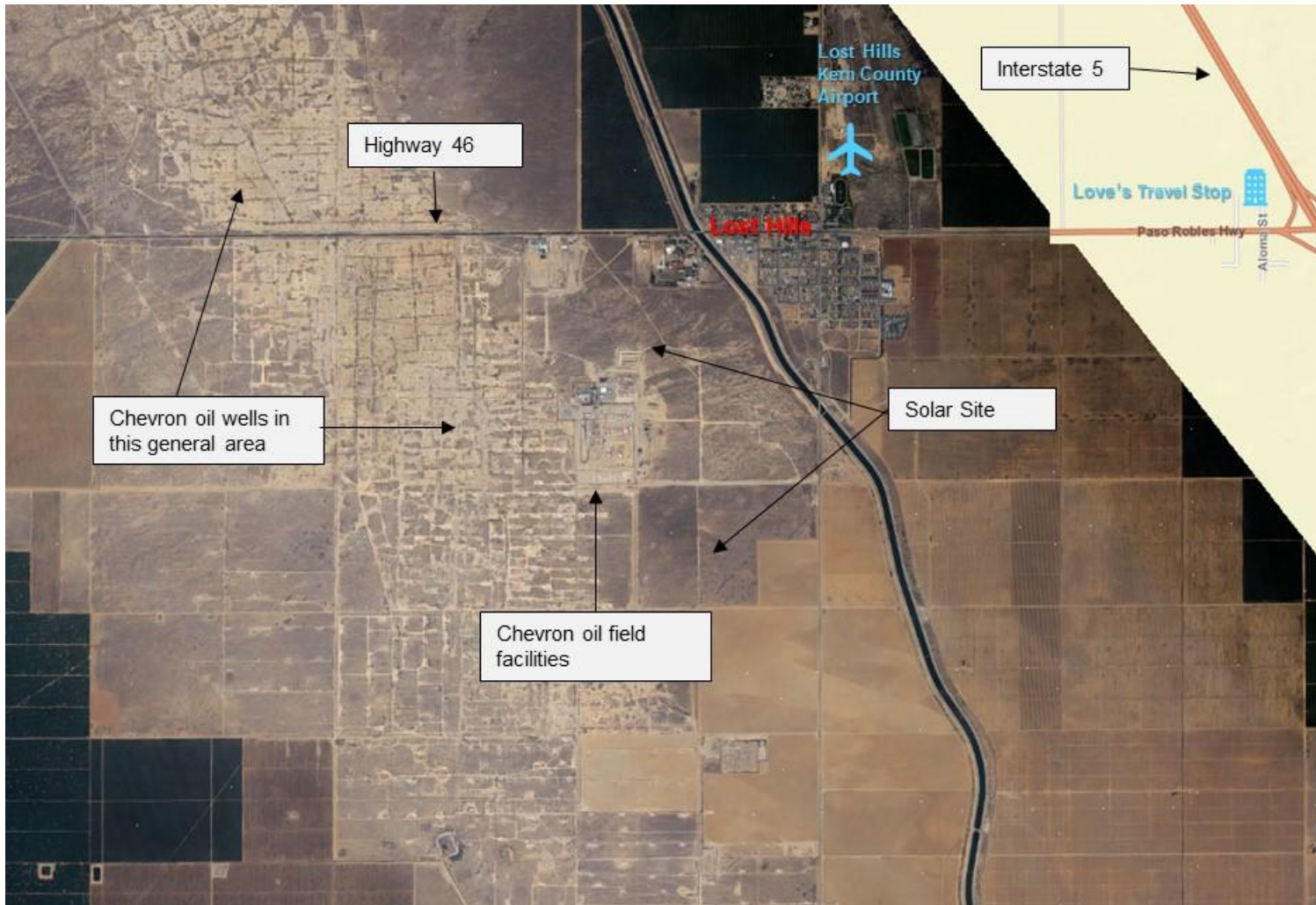

Project Site and Layout

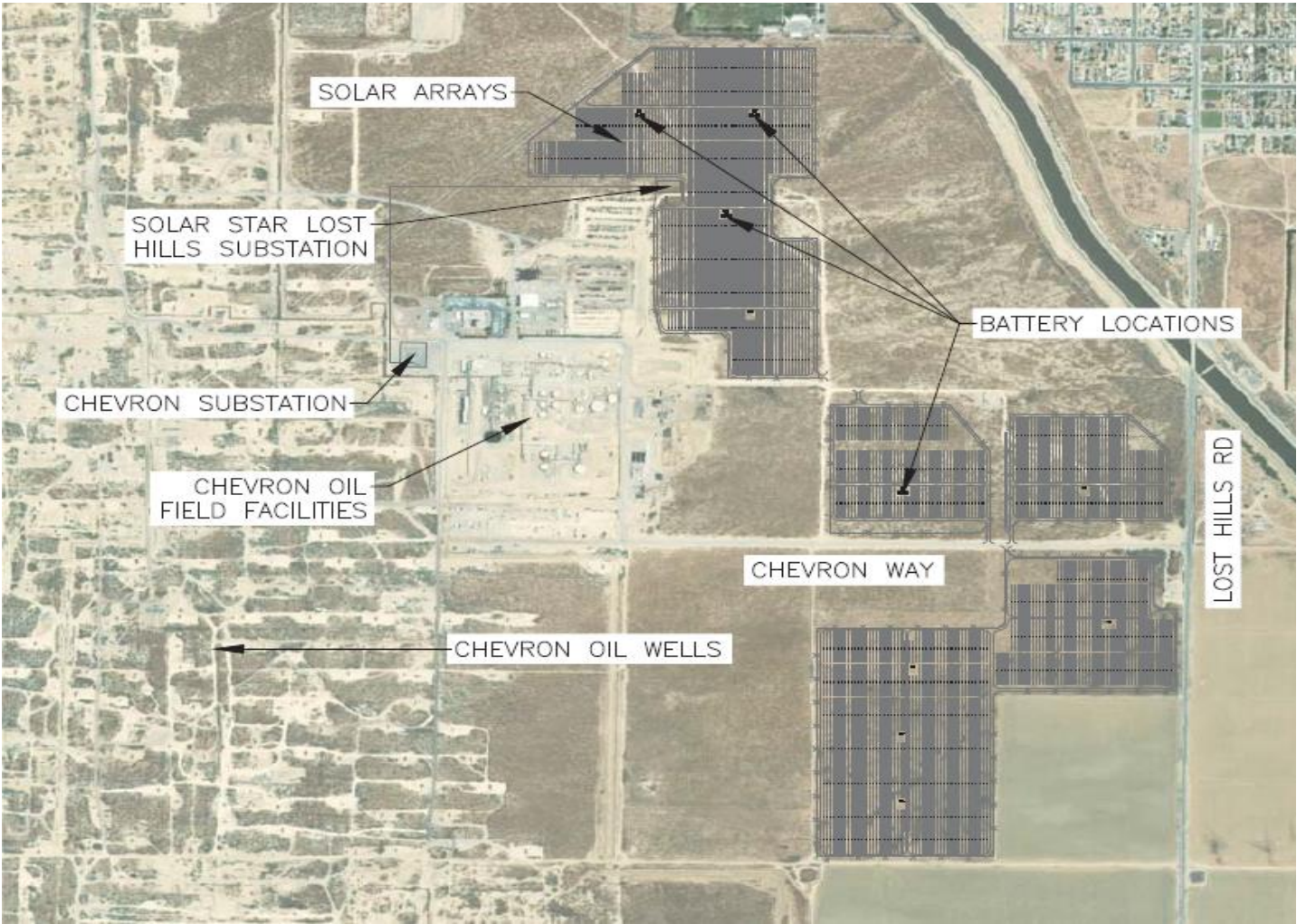

Appendix C: Credit Calculations

Section 95489(c)(1)(F) of the LCFS regulations presents the formula for calculating Innovative Crude credits using solar or wind-based electricity:

$$Credits_{Innov}(MT) = 511 \times \frac{E_{electricity} \times f_{renew}}{V_{crudeproduced}} \times V_{Innov} \times C$$

Where:

$Credits_{Innov}(MT)$ are the amount of LCFS credits generated using the innovative method

$E_{electricity}$ is the overall electricity consumed to produce or transport crude, in kWh

f_{renew} is the fraction of electricity consumed that is produced using qualifying solar or wind power

$V_{crudeproduced}$ is the volume, in barrels, of crude produced using the innovative method

V_{Innov} is the volume, in barrels, of crude produced using the innovative method delivered to California refineries

$C = 1.0 \times 10^{-6} \frac{MT}{gCO2e}$ = conversion factor from grams to metric tons

And:

$\frac{V_{Innov}}{V_{crudeproduced}} =$ fraction of crude delivered to California refineries = 1.0

$E_{electricity} \times f_{renew} =$ total solar electricity consumed in the field

The governing equation above then simply reduces to:

$$Credits_{Innov}(MT) = 511 \times Electricity_{solar} \times C$$

Credits for Solar Consumed Directly in Field – Table C-1 presents average hourly solar power supplied directly to the oilfield by month based on SunPower’s PVSIm software. On an annual basis, this amounts to 38,711,000 kWh of electricity. The credits are then calculated as:

$$Credits_{Innov}(MT) = 511 \times 38,711,000 \times \left[1.0 \times 10^{-6} \frac{MT}{gCO2e} \right] = 19,781 MT$$

Additional Credits for Battery Storage – Table C-2 presents average hourly direct solar plus stored power supplied to the oilfield, also based on SunPower’s PVSIm software. On an annual basis, this amounts to 44,107,000 kWh of electricity. The increment associated with stored solar supplied to the field is 5,396,000 kWh of electricity, which amounts to:

$$Credits_{Innov}(MT) = 511 \times 5,396,000 \times \left[1.0 \times 10^{-6} \frac{MT}{gCO2e} \right] = 2,757 MT$$

When battery storage capability is fully functional, the overall LCFS credits associated with the Lost Hills solar project is expected to be 22,538 metric tons per year in the first year.

Table C-1: Average Hourly Solar Power Supplied Directly to Field (MW)

Hour of Day	Month												<u>Annual</u>	
	<u>1</u>	<u>2</u>	<u>3</u>	<u>4</u>	<u>5</u>	<u>6</u>	<u>7</u>	<u>8</u>	<u>9</u>	<u>10</u>	<u>11</u>	<u>12</u>		
0	0.00	0.00	0.00	0.00	0.00	0.00	0.00	0.00	0.00	0.00	0.00	0.00	0.00	
1	0.00	0.00	0.00	0.00	0.00	0.00	0.00	0.00	0.00	0.00	0.00	0.00	0.00	
2	0.00	0.00	0.00	0.00	0.00	0.00	0.00	0.00	0.00	0.00	0.00	0.00	0.00	
3	0.00	0.00	0.00	0.00	0.00	0.00	0.00	0.00	0.00	0.00	0.00	0.00	0.00	
4	0.00	0.00	0.00	0.00	0.00	0.00	0.00	0.00	0.00	0.00	0.00	0.00	0.00	
5	0.00	0.00	0.00	0.00	0.00	0.00	0.00	0.00	0.00	0.00	0.00	0.00	0.00	
6	0.00	0.02	0.02	0.19	2.32	3.41	1.88	0.24	0.01	0.00	0.05	0.00	0.00	
7	0.61	4.70	3.13						6.21	1.45	5.36	1.45		
8	5.71													
9	6.68													
10														
11														
12														
13														
14														
15														
16	2.99													
17	0.01	0.35												
18	0.00	0.00	3.38						3.57	0.08	0.00	0.00	0.00	
19	0.00	0.00	0.00	0.12	1.44	4.05	3.10	0.75	0.01	0.00	0.00	0.00	0.00	
20	0.00	0.00	0.00	0.00	0.00	0.00	0.00	0.00	0.00	0.00	0.00	0.00	0.00	
21	0.00	0.00	0.00	0.00	0.00	0.00	0.00	0.00	0.00	0.00	0.00	0.00	0.00	
22	0.00	0.00	0.00	0.00	0.00	0.00	0.00	0.00	0.00	0.00	0.00	0.00	0.00	
23	0.00	0.00	0.00	0.00	0.00	0.00	0.00	0.00	0.00	0.00	0.00	0.00	0.00	
Days per Month:	31	28	31	30	31	30	31	31	30	31	30	31	31	365
Monthly Sum (MWh):	2,017	2,466	3,168	3,609	4,033	4,085	4,177	3,995	3,461	3,064	2,530	2,106	2,106	38,711
Monthly LCFS Credits (MT):	1,030	1,260	1,619	1,844	2,061	2,088	2,134	2,041	1,769	1,566	1,293	1,076	1,076	19,781

Table C-2: Average Hourly Solar + Storage Supplied to Field (MW)

Hour of Day	Month												<u>Annual</u>	
	<u>1</u>	<u>2</u>	<u>3</u>	<u>4</u>	<u>5</u>	<u>6</u>	<u>7</u>	<u>8</u>	<u>9</u>	<u>10</u>	<u>11</u>	<u>12</u>		
0	0.00	0.00	0.00	0.00	0.00	0.00	0.00	0.00	0.00	0.00	0.00	0.00	0.00	
1	0.00	0.00	0.00	0.00	0.00	0.00	0.00	0.00	0.00	0.00	0.00	0.00	0.00	
2	0.00	0.00	0.00	0.00	0.00	0.00	0.00	0.00	0.00	0.00	0.00	0.00	0.00	
3	0.00	0.00	0.00	0.00	0.00	0.00	0.00	0.00	0.00	0.00	0.00	0.00	0.00	
4	0.00	0.00	0.00	0.00	0.00	0.00	0.00	0.00	0.00	0.00	0.00	0.00	0.00	
5	0.00	0.00	0.00	0.00	0.00	0.00	0.00	0.00	0.00	0.00	0.00	0.00	0.00	
6	0.00	0.00	0.02	0.16	2.30	3.39	1.86	0.21	0.00	0.00	0.03	0.00	0.00	
7	0.58	4.67	3.10	7.67					6.18	1.42	5.33	1.42		
8	5.69													
9	5.73													
10	6.35													
11	6.86													
12														
13														
14														
15														
16														
17	6.48												6.25	
18	3.38	6.47									2.97	1.71		
19	0.06	1.68	5.10	6.13						6.06	0.36	0.00		
20	0.00	0.00	4.98	5.88	6.12					0.91	0.00	0.00		
21	0.00	0.00	0.00	0.00	0.00	0.00	0.00	0.00	0.00	0.00	0.00	0.00		
22	0.00	0.00	0.00	0.00	0.00	0.00	0.00	0.00	0.00	0.00	0.00	0.00		
23	0.00	0.00	0.00	0.00	0.00	0.00	0.00	0.00	0.00	0.00	0.00	0.00		
Days per Month:	31	28	31	30	31	30	31	31	30	31	30	31		365
Monthly Sum (MWh):	2,339	2,884	3,644	4,010	4,456	4,530	4,655	4,504	4,027	3,591	2,994	2,472		44,107
Monthly LCFS Credits (MT):	1,195	1,474	1,862	2,049	2,277	2,315	2,379	2,301	2,058	1,835	1,530	1,263		22,539

Appendix D: Estimated Power Generation

A typical meteorological year was used to estimate the electrical power generation using SunPower's PVSIM software. Estimated monthly solar electrical power generation is shown in the chart below.

1. Solar Consumed is the solar power used directly by the field in real time
2. Storage Consumed is solar power stored in the batteries and used directly by the field
3. NEM Exports shows the excess solar power exported to the grid for utility bill credits

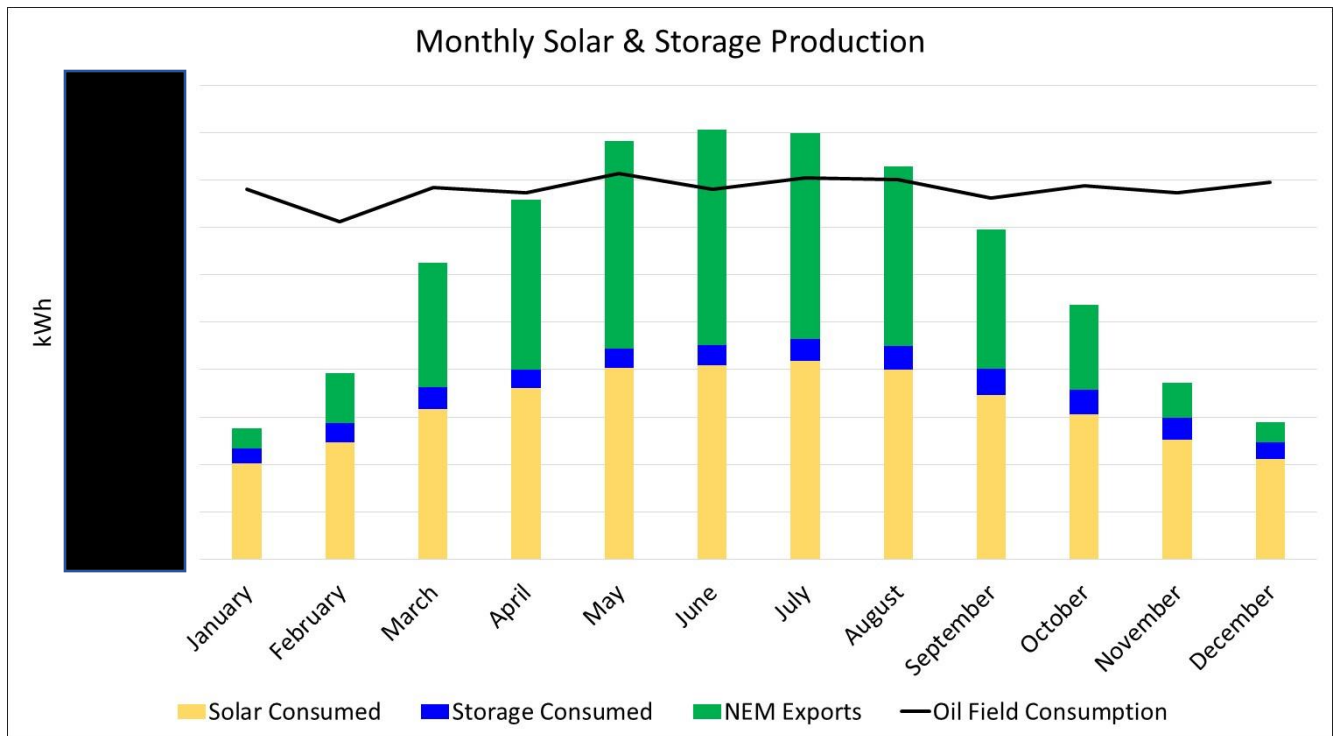

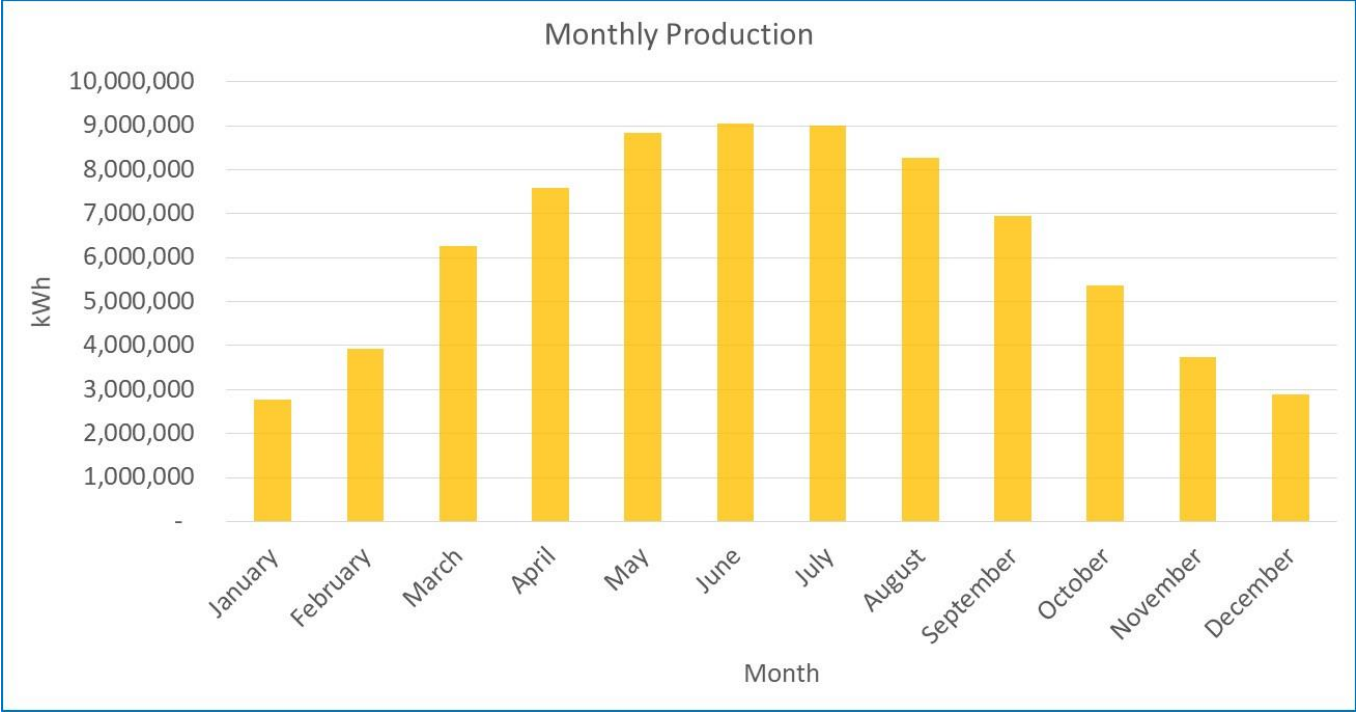

Power generation on a typical winter and summer day, with and without battery storage is shown on the charts below.

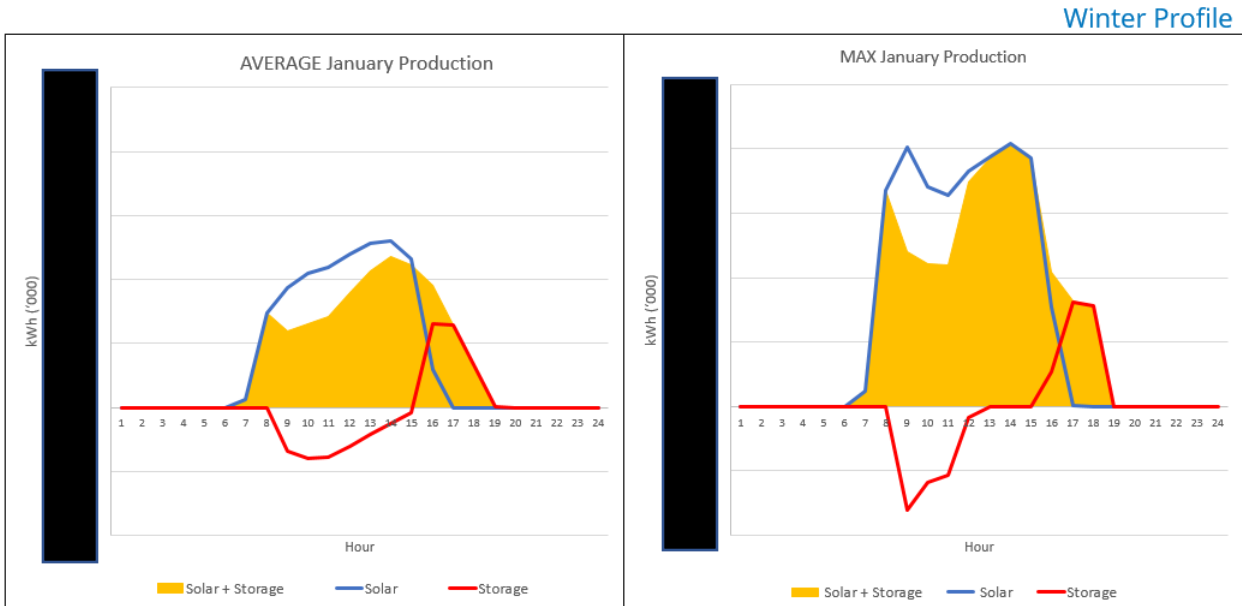

Summer Profile

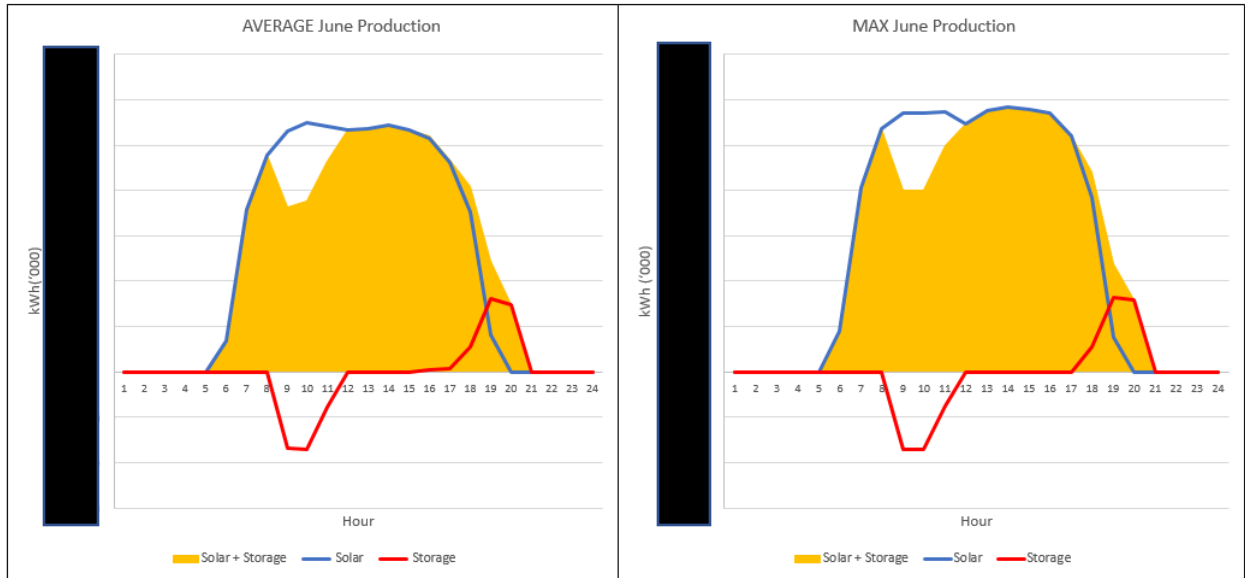

Appendix E: Refining of Lost Hills Crude

The sale of Lost Hills oil is managed by Chevron's Crude Supply and Trading team. Currently, Lost Hills oil is being sold [REDACTED] pipeline that goes to [REDACTED] in the [REDACTED] and [REDACTED]. In the [REDACTED], [REDACTED] and [REDACTED] are the major customers. Lost Hills crude is marketed and transported to refiners under the name "SJVL" which stands for San Joaquin Valley Light.

Appendix F: Sample Calculations Using Proposed Metering Approach

As requested by CARB staff, this appendix presents sample calculations for the solar power used in the Lost Hills oil field that is eligible for LCFS credits as allowed under §95489(c) of the regulations, *Credits for Producing and Transporting Crudes using Innovative Methods*. Two cases are presented: (1) Solar PV Only and (2) Solar PV with Battery Storage and Discharge.

A detailed diagram of the metering approach for the solar plant and oil field is shown in Figure F-1. As described in the body of this report, electricity produced by the solar plant will exceed the field load during the day, and power in excess of the field load will be exported to PG&E. At night, the field will be powered by the PG&E grid. Two meters will be used to collect data on power consumption and generation:

- Net Meter “A” measures power imported from (kWh IN) and exported to (kWh OUT) PG&E
- PV Meter “B” measures solar and battery power exported from (kWh OUT) and imported to (kWh IN) the Solar Plant

These two meters will be configured such that separate channels will be used to record power imported versus power exported. As a result, there will be four data streams for which power will be recorded in 15-minute intervals. The meters will record power cumulatively, and the meters will be reset to zero on either a monthly basis or another interval depending on operational conditions.

Table F-1 below shows a simplified example of meter readings and computed data for a short time period in the morning during which the PV system becomes active and begins to generate electricity. Cumulative raw data from the meters are shown in columns A to D, while 15-minute interval data calculated by taking the difference between one cumulative reading and the next (e.g., from 5:30 AM to 5:45 AM) are shown in columns E to H. Column I shows the resulting values for PV solar that is consumed in the oil field and eligible to generate LCFS credits. Sample calculations using the simplified data in Table F-1 are presented below.

Figure F-1: Lost Hills Solar Metering Configuration

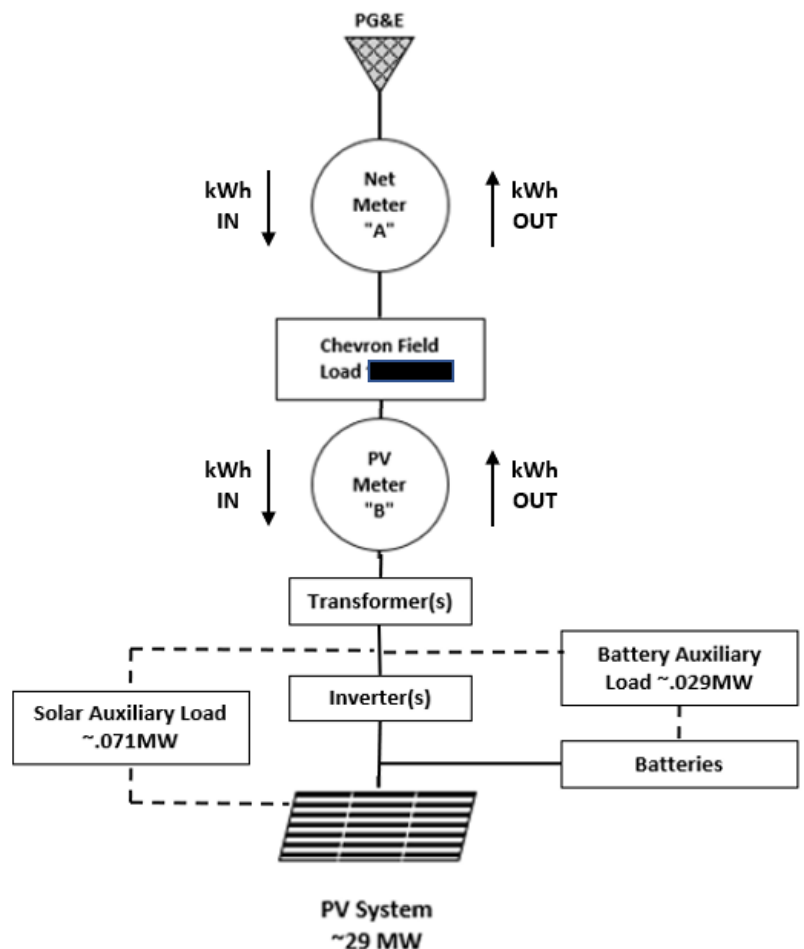

Table F-1: Simplified Example of Meter Readings and Calculated Data

Time	Cumulative Raw Data from Meters				Interval Data Computed from Cumulative Data				Solar to Field kWh
	PV Meter B kWh IN	PV Meter B kWh OUT	Net Meter A kWh IN	Net Meter A kWh OUT	PV Meter B kWh IN	PV Meter B kWh OUT	Net Meter A kWh IN	Net Meter A kWh OUT	
5:15AM	0	0	0	0	--	--	--	--	--
5:30AM	10	0	█	█	10	0	█	█	0
5:45AM	20	0	█	█	10	0	█	█	0
6:00AM	20	160	█	█	0	160	█	█	█
6:15AM	20	410	█	█	0	250	█	█	█
6:30AM	20	840	█	█	0	430	█	█	█
Column	A	B	C	D	E	F	G	H	I

The example data shown in Table F-1 assumes that the cumulative meter readings were reset to zero at 5:15 AM. Thus, 15-minute interval data computed from the raw meter data are shown to begin at 5:30 AM. Three sample calculations for the highlighted cells in Table F-1 are presented below.

Interval Data for PV Meter B - kWh IN @ 5:45 AM (Column E):

Cumulative PV Meter B - kWh IN @ 5:30 AM (Column A) = 10

Cumulative PV Meter B - kWh IN @ 5:45 AM (Column A) = 20

Interval Data for PV Meter B - kWh IN @ 5:45 AM = 20 - 10 = 10 kWh

This value represents a small auxiliary load to the solar plant when PV solar is not being generated and battery storage is not being discharged. Based on CARB guidance, this value is ignored in estimating power for LCFS credits.

Interval Data for PV Meter B - kWh OUT @ 6:15 AM (Column F):

Cumulative PV Meter B - kWh OUT @ 6:00 AM (Column B) = 160

Cumulative PV Meter B - kWh OUT @ 6:15 AM (Column B) = 410

Interval Data for PV Meter B - kWh OUT @ 6:15 AM = 410 - 160 = 250 kWh

This value represents power being generated by the PV system (or battery storage during discharge) and being sent to the oil field. If this value is greater than the field demand, excess will be exported to the grid, which for this example is shown in column H as █ kWh measured by Net Meter A - kWh OUT.

Solar Power to Field @ 6:15 AM (Column I):

Interval Data PV Meter B - kWh OUT @ 6:15 AM (Column F) = 250

Interval Data Net Meter A - kWh OUT @ 6:15 AM (Column H) = █

Solar Power to Field @ 6:15 AM = 250 - █ = █ kWh

This value represents power being consumed by the oil field and eligible for LCFS credits. It is calculated by the formula: IF Column F = 0;

Then Column I = 0;

Else Column I = Column F - Column H;

Two more detailed, 24-hour examples are presented in the tables that follow. The first (Table F-2) assumes only PV generation, while the second (Table F-3) represents PV generation coupled with battery storage and discharge. The data in these examples are based on SunPower modeling of a mid-March day.

Table F-2: Example Calculation of Daily Solar PV Power to Oilfield (No Battery Storage)

Solar PV Only (No Battery Storage)									
Time	Cumulative Raw Data from Meters				Interval Data Computed from Cumulative Data				Solar to Field kWh
	PV Meter B kWh IN	PV Meter B kWh OUT	Net Meter A kWh IN	Net Meter A kWh OUT	PV Meter B kWh IN	PV Meter B kWh OUT	Net Meter A kWh IN	Net Meter A kWh OUT	
0:15	18	0		0	18	0		0	0
0:30	36	0		0	18	0		0	0
0:45	53	0		0	18	0		0	0
1:00	71	0		0	18	0		0	0
1:15	89	0		0	18	0		0	0
1:30	107	0		0	18	0		0	0
1:45	124	0		0	18	0		0	0
2:00	142	0		0	18	0		0	0
2:15	160	0		0	18	0		0	0
2:30	178	0		0	18	0		0	0
2:45	195	0		0	18	0		0	0
3:00	213	0		0	18	0		0	0
3:15	231	0		0	18	0		0	0
3:30	249	0		0	18	0		0	0
3:45	266	0		0	18	0		0	0
4:00	284	0		0	18	0		0	0
4:15	302	0		0	18	0		0	0
4:30	320	0		0	18	0		0	0
4:45	337	0		0	18	0		0	0
5:00	355	0		0	18	0		0	0
5:15	373	0		0	18	0		0	0
5:30	391	0		0	18	0		0	0
5:45	408	0		0	18	0		0	0
6:00	426	0		0	18	0		0	0
6:15	444	0		0	18	0		0	0
6:30	462	0		0	18	0		0	0
6:45	479	0		0	18	0		0	0
7:00	479	751			0	751		0	
7:15	479	2751			0	2000			
7:30	479	5851			0	3100			
7:45	479	10151			0	4300			
8:00	479	15651			0	5500			
8:15	479	21751			0	6100	0		
8:30	479	28076			0	6325	0		
8:45	479	34526			0	6450	0		
9:00	479	41076			0	6550	0		
9:15	479	47710			0	6635	0		
9:30	479	54385			0	6675	0		
9:45	479	61085			0	6700	0		
10:00	479	67720			0	6635	0		
10:15	479	74195			0	6475	0		
10:30	479	80570			0	6375	0		
10:45	479	86870			0	6300	0		
11:00	479	93150			0	6280	0		
11:15	479	99387			0	6237	0		
11:30	479	105617			0	6230	0		
11:45	479	111837			0	6220	0		

12:00	479	118047			0	6210	0		
12:15	479	124242			0	6194	0		
12:30	479	130436			0	6194	0		
12:45	479	136630			0	6194	0		
13:00	479	142880			0	6250	0		
13:15	479	149180			0	6300	0		
13:30	479	155583			0	6402	0		
13:45	479	162033			0	6450	0		
14:00	479	168583			0	6550	0		
14:15	479	175233			0	6650	0		
14:30	479	181933			0	6700	0		
14:45	479	188533			0	6600	0		
15:00	479	195133			0	6600	0		
15:15	479	201633			0	6500	0		
15:30	479	208033			0	6400	0		
15:45	479	214133			0	6100	0		
16:00	479	219583			0	5450	0		
16:15	479	223983			0	4400	0		
16:30	479	227583			0	3600	0		
16:45	479	230583			0	3000	0		
17:00	479	232983			0	2400	0		
17:15	479	234683			0	1700	0		
17:30	479	235683			0	1000	0		
17:45	497	235683			18	0	0	0	0
18:00	515	235683			18	0	0	0	0
18:15	533	235683			18	0	0	0	0
18:30	550	235683			18	0	0	0	0
18:45	568	235683			18	0	0	0	0
19:00	586	235683			18	0	0	0	0
19:15	604	235683			18	0	0	0	0
19:30	621	235683			18	0	0	0	0
19:45	639	235683			18	0	0	0	0
20:00	657	235683			18	0	0	0	0
20:15	675	235683			18	0	0	0	0
20:30	692	235683			18	0	0	0	0
20:45	710	235683			18	0	0	0	0
21:00	728	235683			18	0	0	0	0
21:15	746	235683			18	0	0	0	0
21:30	763	235683			18	0	0	0	0
21:45	781	235683			18	0	0	0	0
22:00	799	235683			18	0	0	0	0
22:15	817	235683			18	0	0	0	0
22:30	834	235683			18	0	0	0	0
22:45	852	235683			18	0	0	0	0
23:00	870	235683			18	0	0	0	0
23:15	888	235683			18	0	0	0	0
23:30	905	235683			18	0	0	0	0
23:45	923	235683			18	0	0	0	0
24:00	941	235683			18	0	0	0	0
kWh/day for LCFS Credit:									109,015

Table F-3: Example Calculation of Daily Solar PV Power to Oilfield with Battery Storage and Discharge

Solar PV with Battery Storage and Discharge									
Time	Cumulative Raw Data from Meters				Interval Data Computed from Cumulative Data				Solar to Field kWh
	PV Meter B kWh IN	PV Meter B kWh OUT	Net Meter A kWh IN	Net Meter A kWh OUT	PV Meter B kWh IN	PV Meter B kWh OUT	Net Meter A kWh IN	Net Meter A kWh OUT	
0:15	25	0		0	25	0		0	0
0:30	50	0		0	25	0		0	0
0:45	75	0		0	25	0		0	0
1:00	100	0		0	25	0		0	0
1:15	125	0		0	25	0		0	0
1:30	150	0		0	25	0		0	0
1:45	175	0		0	25	0		0	0
2:00	200	0		0	25	0		0	0
2:15	225	0		0	25	0		0	0
2:30	250	0		0	25	0		0	0
2:45	275	0		0	25	0		0	0
3:00	300	0		0	25	0		0	0
3:15	325	0		0	25	0		0	0
3:30	350	0		0	25	0		0	0
3:45	375	0		0	25	0		0	0
4:00	400	0		0	25	0		0	0
4:15	425	0		0	25	0		0	0
4:30	450	0		0	25	0		0	0
4:45	475	0		0	25	0		0	0
5:00	500	0		0	25	0		0	0
5:15	525	0		0	25	0		0	0
5:30	550	0		0	25	0		0	0
5:45	575	0		0	25	0		0	0
6:00	600	0		0	25	0		0	0
6:15	625	0		0	25	0		0	0
6:30	650	0		0	25	0		0	0
6:45	675	0		0	25	0		0	0
7:00	675	751			0	751		0	
7:15	675	2751			0	2000			
7:30	675	5851			0	3100			
7:45	675	10151			0	4300			
8:00	675	15651			0	5500			
8:15	675	19587			0	3936	0		
8:30	675	23748			0	4161	0		
8:45	675	28034			0	4286	0		
9:00	675	32420			0	4386	0		
9:15	675	36902			0	4482	0		
9:30	675	41425			0	4522	0		
9:45	675	45972			0	4547	0		
10:00	675	50454			0	4482	0		
10:15	675	55013			0	4558	0		
10:30	675	59471			0	4458	0		
10:45	675	65771			0	6300	0		
11:00	675	72051			0	6280	0		
11:15	675	78289			0	6237	0		
11:30	675	84519			0	6230	0		
11:45	675	90739			0	6220	0		

12:00	675	96949			0	6210	0		
12:15	675	103143			0	6194	0		
12:30	675	109337			0	6194	0		
12:45	675	115532			0	6194	0		
13:00	675	121782			0	6250	0		
13:15	675	128082			0	6300	0		
13:30	675	134484			0	6402	0		
13:45	675	140934			0	6450	0		
14:00	675	147484			0	6550	0		
14:15	675	154134			0	6650	0		
14:30	675	160834			0	6700	0		
14:45	675	167434			0	6600	0		
15:00	675	174034			0	6600	0		
15:15	675	180534			0	6500	0		
15:30	675	186934			0	6400	0		
15:45	675	193034			0	6100	0		
16:00	675	198484			0	5450	0		
16:15	675	202884			0	4400	0		
16:30	675	206484			0	3600			
16:45	675	209484			0	3000			
17:00	675	211884			0	2400			
17:15	675	213584			0	1700			
17:30	675	216193			0	2609			
17:45	675	217802			0	1609		0	
18:00	675	219411			0	1609		0	
18:15	675	221020			0	1609		0	
18:30	675	222611			0	1591		0	
18:45	675	224201			0	1591		0	
19:00	675	225792			0	1591		0	
19:15	675	227383			0	1591		0	
19:30	675	228957			0	1574		0	
19:45	675	230531			0	1574		0	
20:00	675	232105			0	1574		0	
20:15	675	233678			0	1574		0	
20:30	700	233678			25	0		0	
20:45	725	233678			25	0		0	
21:00	750	233678			25	0		0	0
21:15	775	233678			25	0		0	0
21:30	800	233678			25	0		0	0
21:45	825	233678			25	0		0	0
22:00	850	233678			25	0		0	0
22:15	875	233678			25	0		0	0
22:30	900	233678			25	0		0	0
22:45	925	233678			25	0		0	0
23:00	950	233678			25	0		0	0
23:15	975	233678			25	0		0	0
23:30	1000	233678			25	0		0	0
23:45	1025	233678			25	0		0	0
24:00	1050	233678			25	0		0	0
kWh/day for LCFS Credit:									128,109

Appendix G: Recordkeeping and Reporting Plan

In accordance with §95489 Subchapter C, Article 4, Sections A-D, Chevron plans to report the following items on a quarterly basis in order to consistently earn LCFS credits:

- A. The volume of barrels of crude oil produced or transported under the market name “SJVL” – indicating light crude oil produced in Lost Hills, California
- B. If blending is applicable, the name and volume fraction of the blend that is produced under the innovative crude method
- C. Pipeline statements documenting that the innovative crude oil produced was supplied to one or more California refinery gates and the volume of barrels delivered to each
- D. Solar-specific:
 1. Metered data on solar electricity consumed for crude oil production during the quarter (kWh)
 2. Metered data on **total** electricity consumed for crude oil production during the quarter (kWh)
 3. A letter attesting that all solar electricity eligible for LCFS credits was supplied directly for crude oil production and that it did not produce renewable energy certificates or other credited environmental attributes, other than the market-based compliance mechanism set forth in title 17, California Code of Regulations Chapter 1, Subchapter 10, article 5 (commencing with section 95800)