

Reporting Guidance for Electricity Generating and Cogeneration Units for California's Mandatory Greenhouse Gas Reporting Regulation

Introduction

This document describes the reporting requirements for operators of electricity generating units (including cogeneration) subject to the Regulation for the Mandatory Reporting of Greenhouse Gas Emissions (title 17, California Code of Regulations, sections 95100-95158) (regulation or MRR).

Unlike MRR, this guidance does not have the force of law, does not establish new mandatory requirements for greenhouse gas (GHG) reporting, and in no way supplants, replaces, or amends any of the legal requirements of the Regulation. Conversely, an omission or truncation of regulatory requirements in this guidance does not relieve operators of their legal obligation to fully comply with all requirements of MRR.

The reporting requirements for Electricity Generation Units (EGU) are specified in section 95112 of MRR, with references to Title 40, United States Environmental Protection Agency (U.S. EPA) Code of Federal Regulation (CFR), Part 98 Subparts C and D, and to section 95115 of MRR for emissions calculation methods and fuel sampling and monitoring requirements. Because 40 CFR Part 98 does not require reporting of the energy generation information required in section 95112, section 95112 requirements have no counterpart in 40 CFR Part 98. Although Subpart D of the U.S. EPA regulation is titled "Electricity Generation," it only provides instruction for emissions reporting for Part 75 generation units. Under the federal reporting program, any applicable non-Part-75 EGUs are treated as general stationary fuel combustion sources, while MRR includes the same reporting requirements for both Part 75 and non-Part 75 EGUs.

This document focuses on rule applicability, reporting requirements, system energy accounting, verification requirements, and several example scenarios for various generation configurations. The current document includes a correction to two figures (example 3b and 4), along with a clarification for cooling energy (page 3).

1 Applicability

The reporting requirements in section 95112 of MRR apply to the following facilities:

Guidance for California's Mandatory Greenhouse Gas Emissions Reporting

- Part 75 power plants, regardless of emissions level, until cessation requirements are met.
- Stand-alone power plants and cogeneration facilities with greater than or equal to 10,000 metric tons carbon dioxide equivalent (MTCO₂e) of emissions.
- Industrial, commercial, or institutional facilities with an on-site EGU that have greater than or equal to 10,000 MTCO₂e of total facility emissions.
- Operators subject to reporting that have any non-fuel-based renewable electricity generating unit, such as solar panels, with nameplate generating capacity of greater than 0.5 megawatts (MW) (section 95112(g)).
- Operators applying for legacy contract transition assistance under section 95894 of the Cap-and-Trade Regulation (sections 95112(a) and (i) of MRR).

2 EGU Reporting Requirements

2.1 Options for <1 MW Facilities

Reporting of EGU data items listed in section 95112 is optional for operators with total nameplate generating capacity less than 1 MW from fuel-based generation. However, the operator still needs to report any fuel-combusting EGU as a stationary combustion source pursuant to the first paragraph of section 95115 and 40 CFR Part 98 Subpart C.

Note: Legacy contract applicants, regardless of capacity, must comply with the requirements of section 95112(i). Also, on-site renewable electricity generation with a generating capacity greater than 0.5 MW has separate requirements as specified in section 95112(g) of MRR (see section 2.8 of this document for more information).

2.2 Bigeneration versus Cogeneration

“Bigeneration” refers to an EGU that simultaneously produces electricity and steam from the same fuel source but *does not* utilize waste heat as is done with a cogeneration system. An example of bigeneration would be a boiler generating steam that is split into two streams, where one stream powers a steam turbine to generate electricity, and the other stream is used for other industrial, commercial, heating, and cooling purposes. The definition of a “bigeneration unit” can be found in section 95102(a). See Example 4 for a graphical illustration of a bigeneration system.

2.3 Total Thermal Output

Operators of cogeneration and bigeneration units must report the unit’s “total thermal output” as defined in section 95102(a), which is the total amount of usable thermal energy that can potentially be made available for use in any industrial or commercial

Guidance for California's Mandatory Greenhouse Gas Emissions Reporting

processes, heating or cooling applications, or delivered to other end users. The total thermal output value does not include any thermal energy used directly for electricity generation (e.g., steam used to drive a steam turbine generator for electricity generation), and it also excludes the heat content of returned condensate and makeup water. The total thermal output includes the following:

- Thermal energy provided or sold to a particular end-user (section 95112(a)(5)(A))
- Separately quantify and report the subset of generated thermal energy that is used to produce cooling energy e.g., chilled water) or distilled water for a particular end-user outside of the facility boundary (section 95112(a)(5)(A))
- Parasitic thermal energy used for supporting power generation that has been included in the quantity reported under section 95112(b)(3) but *that is not accounted for* in the quantities reported under sections 95112(a)(5)(A) and (C). These processes may include, but are not limited to, steam used for power augmentation, NO_x control, de-aerator, cooling tower. If the steam used at those applications has not been included in the quantity reported under section 95112(b)(3), this data item should be zero (section 95112(a)(5)(B)),
- Thermal energy used in other on-site processes or applications (e.g., manufacturing or production process, heating/cooling applications) that are not in support of, or a part of, the electricity generation system (section 95112(a)(5)(C)), and
- Thermal energy that is vented, radiated, wasted, discharged, or otherwise not utilized.

Data associated with these thermal outputs are entered into Subpart A of Cal e-GGRT, as shown in Figures 1 and 2 which follow.

To understand how a facility uses and wastes generated thermal energy, “total thermal output” can be compared to the disposition of thermal energy quantities reported under section 95112(a)(5). The sum of the three quantities reported under section 95112(a)(5) should be less than or equal to the total thermal output quantity reported under section 95112(b)(3), with the difference between the two numbers being the amount of thermal energy not utilized for any useful purpose. For example, for an industrial facility with an on-site cogeneration unit that uses all the steam generated by the cogeneration unit in manufacturing process in the facility, the amount of generated thermal energy not utilized by other useful industrial applications would be calculated as: “total thermal output” quantity reported under section 95112(b)(3), minus the quantity reported under section 95112(a)(5)(C) for generated thermal energy that is used by those on-site industrial processes or operations and heating or cooling

Guidance for California's Mandatory Greenhouse Gas Emissions Reporting

applications, and minus the quantity reported under section 95112(a)(5)(B) for thermal energy used for supporting power production.

Figure 1 – Electricity Generation, Data Entry in Subpart A

ELECTRICITY GENERATION	
Does this facility have the capacity to generate electricity?	<input checked="" type="radio"/> Yes <input type="radio"/> No
ELECTRICITY GENERATING UNIT BASIC INFORMATION	
CEC ID	<input type="text"/> Separate each ID with a comma if more than one.
EIA ID	<input type="text"/> Separate each ID with a comma if more than one.
FERC QFID	<input type="text"/> Separate each ID with a comma if more than one.
CAISO ID	<input type="text"/> Separate each ID with a comma if more than one.
Total Facility Nameplate Generating Capacity:	<input type="text"/> MW
Facility Type	Select <input type="text"/>
Facility's Energy Disposition	Select <input type="text"/>
DISPOSITION OF GENERATED ELECTRICITY [95112(a)(4)]	
<input type="checkbox"/> Generated Electricity for Grid Disposition [95112(a)(4)(A)]	
<input type="checkbox"/> Generated Electricity for Other Users Disposition [95112(a)(4)(B)]	
Generated electricity for on-site industrial applications not related to electricity generation [95112(a)(4)(C)]	<input type="text"/> MWh
PORTION OF GENERATED ELECTRICITY USED TO PRODUCE COOLING ENERGY FOR OTHER END-USERS OR FOR ON-SITE INDUSTRIAL PROCESS NOT IN SUPPORT OF THE POWER GENERATION SYSTEM [95112(a)(4)(C)1-2]	
<input type="checkbox"/> Portion of Generated Electricity used to Produce Cooling Energy For Other End-Users or For On-site Industrial Process Not in Support of the Power Generation System [95112(a)(4)(C)1-2]	

Figure 2 – Cogeneration, Data Entry in Subpart A

COGENERATION / BIGENERATION

Do reported emissions include emissions from a cogeneration/bigeneration unit? Yes No Not applicable because reporting as a fuel or CO2 supplier

COGENERATION / BIGENERATION OPERATOR

If your facility includes cogeneration/bigeneration units, upload a simplified block diagram of the unit(s). [95112(a)(6)]

No file selected.

DISPOSITION OF GENERATED THERMAL ENERGY FOR OTHER USERS FROM COGENERATION/BIGENERATION UNITS[95112(a)(5)(A)]

End-User Name	ARB ID	NAICS	Thermal Energy Provided or Sold (MMBtu)	Energy Product Provided	Delete
ACME	123456	211111	5000	Superheated Steam	✖

[+ ADD End-User Disposition](#)

Provide the following if the facility provides thermal energy from a cogeneration or bigeneration unit.

Parasitic Steam Use: MMBtu
Generated thermal energy used for supporting power production (excluding steam used directly for generating electricity) [95112(a)(5)(B)]

Generated thermal energy for on-site industrial applications not related to electricity generation [95112(a)(5)(C)] MMBtu

PORTION OF GENERATED THERMAL ENERGY USED TO PRODUCE COOLING ENERGY OR DISTILLED WATER FOR OTHER END-USERS OR FOR ON-SITE INDUSTRIAL PROCESS NOT IN SUPPORT OF THE POWER GENERATION SYSTEM [95112(a)(5)(C)1-2]

[+ Portion of Generated Thermal Energy Used to Produce Cooling Energy or Distilled Water for Other End-Users or For On-Site Industrial Process not in support of the Power Generation System. \[95112\(a\)\(5\)\(C\)1-2\]](#)

Figure 3 – Electricity Generating Unit, Data Entry in Subpart C

ELECTRICITY GENERATING UNITS		
Does this Configuration have the capacity to generate electricity? <input checked="" type="radio"/> Yes <input type="radio"/> No		
PART 75 UNIT INFORMATION		
Is this configuration a Part 75 unit? <input type="radio"/> Yes <input type="radio"/> No		
ELECTRICITY GENERATING UNITS BASIC INFORMATION		
Nameplate Generating Capacity	<input type="text"/>	MW
Prime Mover Technology	Select <input type="text"/>	
Type of Thermal Energy Generation	Select <input type="text"/>	
ENERGY GENERATION INFORMATION		
Gross Generation	<input type="text"/>	MWh
Net Generation	<input type="text"/>	MWh
Total Thermal Output (for Cogeneration or Bigeneration) [95112(b)(3)]	<input type="text"/>	mmBtu
OTHER ENERGY INPUTS DATA		
Other Steam Used for EGU [95112(b)(8)]	<input type="text"/>	mmBtu
Input Steam to the Steam Turbine (for bottoming cycle cogeneration units only)	<input type="text"/>	MMBtu
Output of the Heat Recovery Steam Generator (for bottoming cycle cogeneration units only)	<input type="text"/>	MMBtu
SUPPLEMENTAL FIRING INFORMATION (95112(b)(7), IF APPLICABLE)		
Fuel	Percent of Fuel	Purpose of the Supplemental Firing
No Fuel and Unit Types Present		
ADD Supplemental Fuel		

2.4 Net and Gross Electricity Generation

Gross generation is the total electrical output of the EGU, while net generation is gross generation minus parasitic load. Gross and Net Generation are entered into Subpart C of Cal e-GGRT, as shown in Figure 3, previously. In the case of cogeneration, net power generated includes electricity generated that was consumed on-site for the purposes of an industrial production process that is not power generation, power provided directly to particular end users, as well as wholesale power provided to the grid. An engineering estimate of station service or generating unit service power requirements is acceptable. While this engineering estimate does not need to meet calibration requirements of section 95103(k), because it is not emissions or covered product data, the facility operator must be able to demonstrate to the verifier and CARB that the chosen estimation method is reasonable and based on good engineering principles.

Net power generation is used for evaluating efficiency of the generating units. Electricity consumed at the facility when the EGUs were not operating should not be counted against net generation, as doing so would make the EGU appear less efficient. Electricity acquired from sources outside the facility boundary should also not be counted against net generation, but should be accounted in the electricity purchased/acquisition quantity under section 95104(d)(1). Excluding electricity from sources outside the facility boundary is especially important for an EGU with a low capacity factor.¹ Operators should not report a negative net generation number if the station service power requirement is greater than total generation for the year. Instead, operators should exclude from net power generation the power requirements during unit downtime or unit standby, and report that electricity consumption under section 95104(d)(1).

However, for an EGU with a high capacity factor, the facility operator may evaluate whether performing an engineering calculation to separate the parasitic loads during unit operation and unit downtime would result in a significant gain in the system efficiency figure. If the gain in the system efficiency figure is insignificant, the facility operator may report net generation quantity without disaggregating the electricity load during unit operation and unit downtime.

¹ As generally understood in relation to EGU, capacity factor is the ratio of the electrical energy produced by a generating unit for a given period of time to the electrical energy that could have been produced at continuous full power operation during the same period.

2.5 Electricity Generation System Aggregation

Facility operators may aggregate the individual units in an electricity generating system if all the units are integrated into the system. An electricity generating system can be a cogeneration system, a bigeneration system, a combined cycle electricity generation system, or a system with boilers producing steam to feed steam turbine generators. As a general rule, units are considered “integrated” into a single system if the units that generate electricity or thermal energy are not the same units that consume fuels, and the energy output from the system cannot be traced to fuel input at related fuel combustion units in an undivided path in a system energy accounting diagram. If there is more than one system present at the facility, each system must be reported separately. See Section 3 of this document for additional guidance. Guidance for reporting of electricity generation systems can also be found in Examples 1-6 in Section 5 of this document. The [Guidance for Aggregation of Emitting Units](#) also has additional detail on unit aggregation.

2.6 Steam Requirements for Supporting the Electricity Generation System

An electricity generating facility may have power augmentation, de-aeration, NO_x control, or cooling towers that use some of the steam generated by the electricity generating system. An operator must report these steam uses under sections 95112(a)(5)(B) (parasitic steam use) or section 95112(b)(3) (total thermal output) depending on how the electricity generation system boundary is drawn. These data elements are reported in either Subpart A (see Figure 2) or Subpart C (see Figure 3).

If a facility operator considers these thermal energy uses as outside of the electricity generation system boundary, the operator must include the thermal energy in the “total thermal output” quantity (section 95112(b)(3)) and separately report this thermal energy amount in section 95112(a)(5)(B). The sum of the three quantities reported under section 95112(a)(5) corroborate the total thermal output quantity in section 95112(b)(3). However, if the operator considers these applications as within the system boundary, such that the steam used for these applications has not been included in the “total thermal output” quantity reported under section 95112(b)(3), the thermal energy amount in section 95112(a)(5)(B) should be zero. The facility operator should review the availability of the steam meters and the system configuration to decide which option to choose. It is acceptable to use an engineering estimate to calculate the steam flows if there are no steam meters to directly measure all the energy flows required by the regulation. As explained above, the quantity reported under section 95112(b)(3) is the amount of generated thermal energy that leaves the system boundary, and the three quantities reported under section 95112(a)(5) describe what happens to the generated thermal energy after it leaves the system boundary. Whichever way the operator draws

the system boundary and maps the energy flows to the data items in sections 95112(a) and (b), the energy input and output must be fully accounted for.

2.7 Returned Condensate

Most electricity generation facilities with steam turbine generators or heat recovery steam generators (HRSG) have a returned condensate loop to provide feedwater for the boilers and HRSGs. To avoid double counting of the energy in the steam-water loop, the enthalpy of the generated thermal energy must not include the enthalpy of the returned condensate or any makeup water acquired from outside of the facility boundary. The operator can exclude the enthalpy of the feedwater (including returned condensate and makeup water) by simply using the temperature of the feedwater as the reference temperature for the enthalpy calculation of the generated thermal energy. If the steam meters and the computerized data acquisition system are set up such that the reference temperature of the generated steam is different from the temperature of the feedwater, the operator must make an adjustment calculation when reporting thermal energy output.

2.8 Non-Fuel-Based Renewable EGU

To complete the facility energy accounting at facilities already subject to GHG reporting, operators with on-site renewable energy generation systems greater than 0.5 MW must report basic information on such systems, including nameplate capacity and electricity sold to the grid or other end users (section 95112(g)). The data are reported in Subparts A and C of Cal e-GGRT (see Figures 1-3), and this requirement completes the facility energy balance and also ensures fair accounting of energy efficiencies among facilities in the same industry sector. In the reporting tool, facility operators are to create a Subpart C unit configuration with zero fuel and zero emissions, but fill out the EGU and electricity generation data as required by section 95112. The nameplate generating capacity of the non-fuel-based renewable EGU should be included in the facility total nameplate capacity.

2.9 Facility Type and Facility Energy Disposition Selection

Section 95112(a)(3) of the regulation requires facility operators to indicate the type of facility. Specifically, the selections are made for the Facility Type and the Facility's Energy Deposition fields in Subpart A of Cal e-GGRT, as shown in Figure 1. The sections in the tool indicate whether the facility is a:

- stand-alone electricity generating facility;
- independently operated cogeneration facility co-located with the thermal host;

Guidance for California's Mandatory Greenhouse Gas Emissions Reporting

- independently operated bigeneration facility co-located with the thermal host;
- independently operated and sited cogeneration facility;
- independently operated and sited bigeneration facility;
- industrial/institutional/commercial facility with electricity generation capacity;
- reporting non-fuel-based renewable EGU only; or
- geothermal facility.

These terms are defined in section 95102(a). The difference between an independently operated cogeneration/bigeneration facility co-located with the thermal host and an independently operated and sited cogeneration/bigeneration facility is that the former is located on contiguous property as the thermal host and/or is located within the same property fence line; the latter is located on separate properties that are not contiguous. Treatment of facility boundaries for both of these facility types is the same. However, if the cogeneration/bigeneration operator and the thermal host have any common operational control or common ownership, and they are located on contiguous or adjacent properties, they must be included in a single facility boundary pursuant to the "facility" definition (section 95102(a)). In this case, this facility becomes an industrial/institutional/commercial facility with electricity generation capacity, and any applicable emission sources of the thermal host must also be included in the combined GHG report of the cogeneration/bigeneration facility and thermal host.

Section 95112(a)(3) also requires facility operators to indicate whether the electricity generation facility is a grid-dedicated facility or a facility that does not provide any generated energy outside of the facility boundary. The term "grid-dedicated facility" is defined in section 95102(a). To be considered a "facility that does not provide any generated energy outside of the facility boundary," the facility must not provide or sell any generated electricity and thermal energy to any entities outside of the facility boundary. This selection is made in Subpart A of the tool, as shown in Figure 1. **Note:** The facility boundary is defined by the "facility" definition in section 95102(a) and not necessarily by the fence line of the physical property. Reporting under sections 95112(a)(4)-(6) is optional for facilities that do not provide or sell any generated energy outside of the facility boundary (see section 95112(a)). If a facility is neither a "grid-dedicated facility" nor a "facility that does not provide or sell any generated energy outside of the facility boundary," the facility operator should select the "none of the above" option in the Cal e-GGRT pull-down menu. Example 6 in Section 5 of this document is a "grid-dedicated facility," while facilities in Examples 1-5 would select "none of the above" for the Facility's Energy Disposition.

2.10 Reporting of Supplemental Firing Information

If there is supplemental firing within the boundary of an electricity generating system that is being reported as an aggregated unit configuration, the fuel consumption for supplemental firing must be reported in the total fuel quantity for the system along with the primary fuel consumption. In Cal e-GGRT, data fields have been added for reporting supplemental firing information. Reporters will report the total summed fuel consumption of the electricity generating system in the *Fuel-Specific Emissions Information* sub-module, and then separately indicate the portion of fuel consumption (as a percentage of the total fuel use by the system) that is supplemental firing in the supplemental firing data fields of the *Configuration Information* sub-module in the unit configuration. See the bottom of Figure 3 for where the supplemental firing data is entered in Cal e-GGRT. Cal e-GGRT does not double count the supplemental firing fuel when summing the facility fuel use and emissions.

3 System Energy Accounting, Section 95112(a)-(b)

The requirements in sections 95112 and 95104(d) of MRR provide a framework to comprehensively account for the energy inputs and outputs of the EGU and electricity generating system. Section 95112(a) accounts for the disposition of the generated energy at the facility level, while section 95112(b) accounts the energy inputs and outputs of the electricity generating system. To ensure that system energy flows are completely accounted for, a system energy diagram is critical. Facility operators should follow the steps below in reporting the information in sections 95112(a) and (b). Skipping any of these steps has led to instances of operators reporting erroneous information in previous years.

1. Draw a simplified block diagram (sections 95112(a)(6) and 95102(a)) to include the following:
 - Equipment associated with the electricity generating system, and any equipment outside of the electricity generating system that may inform energy flows,
 - Flows of energy (e.g., fuel input, electricity output, heat/steam output) shown with arrows and labels, and
 - Relative location of fuel meters and other fuel quantity measurement devices. If necessary, use more than one diagram for legibility.
2. Draw the system boundary of each electricity generating system. See Examples 1-6 in Section 5 of this document for graphical illustrations. Also

see the [Guidance for Aggregation of Emitting Units](#) for further guidance on aggregating units in a system.

3. Identify the energy flows that cross the electricity generating system boundary by identifying the energy flow “arrows” that cross the system boundary box. Map the energy flows to the data items in section 95112(b).
4. Identify the processes, operations, and destinations to which generated energy is supplied. Account for all the energy dispositions by identifying the energy flows that cross the generating system boundary and the facility boundary. Map them to the data items in section 95112(a).
5. Calculate the quantities required by sections 95112(a) and (b), and enter data into the GHG report accordingly.
6. Beginning January 1, 2015, facility operators that are applying for legacy contract assistance under the Cap-and-Trade Regulation have additional block-diagram reporting requirements as specified in sections 95112(a) and 95112(i) of MRR and summarized below. These requirements apply regardless of whether the facility provides any electricity outside the facility boundary.
 - The block diagram must indicate where each energy flow or product is measured, and whether or not it was provided under the legacy contract. All energy products must be labeled with the type of thermal energy product such as steam, hot water, chilled water, or distilled water.
 - All equipment in the system associated with the legacy contract transition assistance, and equipment that produces or consumes energy that is sent to or received from that system, must be separately included and identified in the block diagram. The diagram must also include the amount of fuel consumed in million British thermal units (MMBtu) by each piece of equipment, as well as the associated CO₂e emissions, and the fuel meter(s) where fuel is measured.
 - The block diagram must include an outline showing the boundary of the activities covered by the legacy contract.

Examples 1-6 in Section 5 of this document illustrate the system boundary, energy inputs and outputs at the system level and the facility level, and mapping of the energy flows to the reporting requirements of sections 95112(a) and (b) for six electricity generating facility configurations.

There are many combinations of generating system configurations. Facility operators may need to refer to more than one of these examples when working through the system energy accounting of their specific facility. Also note that in the interest of

presenting a more legible graphical illustration of an energy system analysis, the diagrams in these examples do not show the location of fuel measurement devices and other equipment that may be associated with the system. Therefore, the example diagrams do not meet the requirements for simplified block diagrams as specified in section 95112(a)(6), which must be submitted by cogeneration and bigeneration operators and legacy contract applicants.

4 Verification of Energy Disposition Data

The information required by section 95112 supports important Cap-and-Trade Program activities and other CARB program activities. As required by section 95131(b)(8)(F)3., verifiers must conduct data checks for reported energy disposition (thermal energy and electricity) to ensure conformance with the regulation (e.g., complete block diagrams and data reporting) and determine whether the information is correctly reported in the following three cases:

1. The facility belongs to an industry sector listed in Table 8-1 of section 95870 of the cap-and-trade regulation;
2. The facility is applying for legacy contract transition assistance under the cap-and-trade regulation; or
3. The facility is applying for the limited exemption of emissions from the production of qualified thermal output pursuant to the cap-and-trade regulation.

In other cases, data checks for reported energy disposition must be conducted when warranted by the verifier's risk analysis and sampling plan. When evaluating cogeneration systems for conformance with the requirements in section 95112, verification bodies should first request a copy of the block diagram(s) or system energy accounting diagram(s) in order to ensure full accounting of all thermal energy.

For example, if a detailed block diagram and system balance diagram are provided to the verification body, along with calibration records for steam meters used to report thermal energy, the verification body may identify the data in section 95112 as having a low risk of reporting errors. However, if detailed information is not provided to the verification body, and the accuracy of the metering system used to estimate thermal energy is not well understood by the operator, the verification body may need to spend more time evaluating the thermal energy data.

If a steam meter is not providing quality-assured values, either because it was not calibrated, or because the meter is not designed to accurately measure the type of steam being used in a process, the verification body can accept industry standard engineering estimates or data from other similar meters and processes at other sites as

sufficient evidence that the reported thermal energy is a reasonable estimate and in conformance with the regulation.

Verification bodies may also identify reported electricity data as low risk at most facilities because of a lower uncertainty in metering devices. Like steam production, electricity production is not evaluated for material misstatement.

5 Examples of System Energy Accounting and Reporting Requirements

Example 1. A Cogeneration System and an Auxiliary Boiler

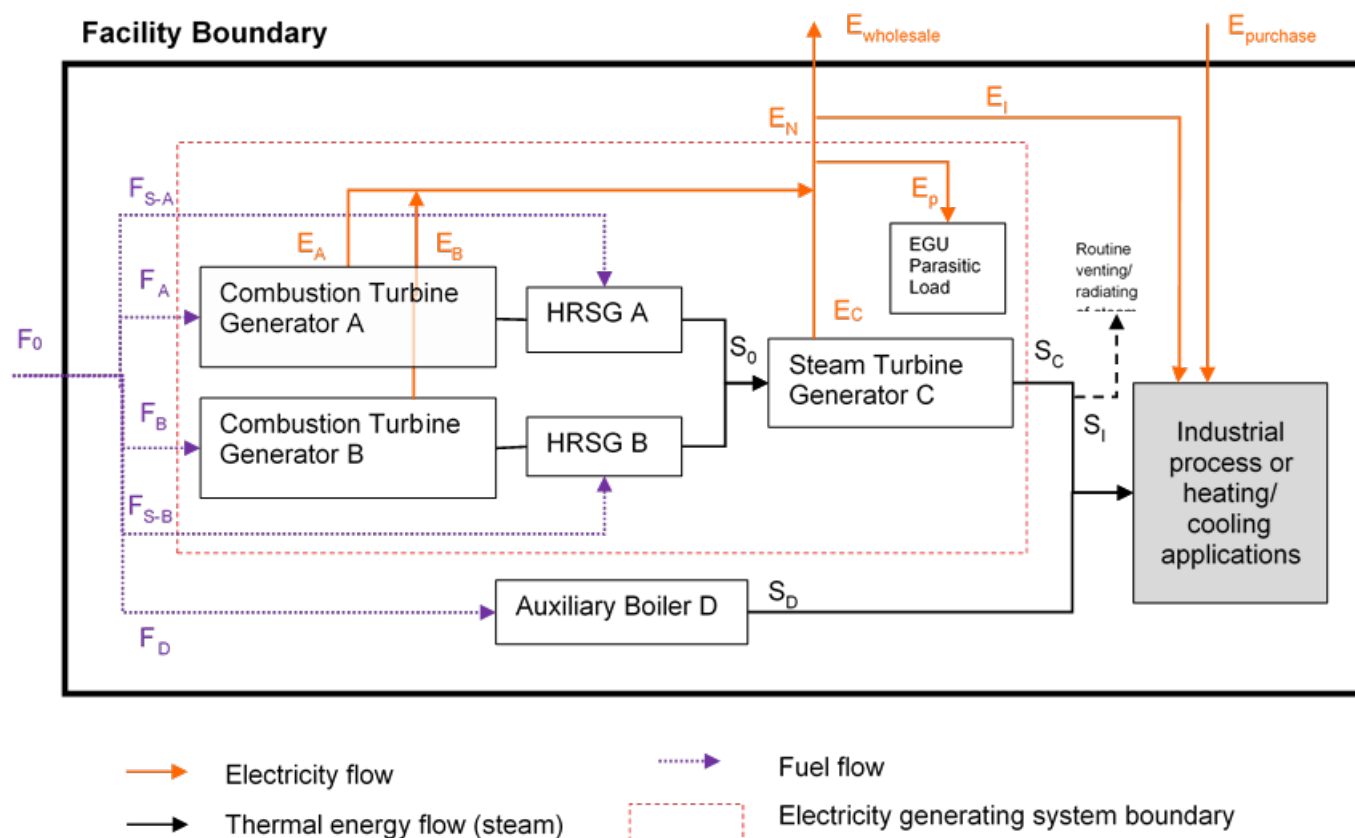

Note: In the interest of presenting a more legible graphical illustration of an energy system analysis, this diagram does not show the location of fuel measurement devices and other equipment that may be associated with the system. Therefore, the diagram as shown does not meet all the requirements of section 95112(a)(6) for a simplified block diagram.

This example shows a cogeneration facility that is an *industrial/institution/commercial facility with electricity generation capacity* (sections 95112(a)(3); 95102(a)). The facility includes two combustion turbine generators, each with a HRSG that produces steam to power a steam turbine generator for electricity generation. When the cogeneration system is not generating steam, an auxiliary boiler supplies steam to the on-site industrial process or heating/cooling (IPHC) applications. Because the auxiliary boiler

does not contribute to electricity generation, it is not considered a part of the electricity generating system and must be reported separately from the cogeneration system.

System Boundary: The cogeneration system boundary is drawn to include the two combustion turbine generators, the two HRSGs, and the steam turbine generator, as shown by the red dashed-line box in the diagram. To identify energy quantities to be reported under section 95112(b), look for any arrows that cross the red dashed-line (F_{S-A} , F_A , F_B , F_{S-B} , S_C , and E_N which is the net generation). Arrows that do not cross the system boundary (S_0 and E_p), should not be reported under section 95112(b) because doing so would result in double counting of energy flows of the system. However, E_p is indirectly accounted for in section 95112(b)(2) by the reporting of gross generation and net generation, which is the sum of gross generation from the three generators (E_A , E_B , and E_C) minus the parasitic load of the electricity generating system (E_p).

Facility-Level Energy Input-Output: The energy quantities reported under section 95112(a) account for the dispositions of the generated energy. In this example, some of the electricity generated by the cogeneration system is sold to a retail provider or electricity marketer who distributes the electricity over the grid (section 95112(a)(4)(A)), and some of the generated electricity is used for on-site IPHC applications (section 95112(a)(4)(C)). This facility does not sell generated electricity to another "particular end-user" facility (as defined in section 95102(a)). Therefore, the quantity reported under section 95112(a)(4)(B) is zero.

Thermal Output: All the steam generated by this cogeneration system is used for the on-site IPHC applications within the facility boundary. If this system is designed to match the steam demand of the IPHC applications, such that there is no routine venting, radiating, wasting, or discharging of the generated steam, S_i (section 95112(a)(5)(C)) and S_C (section 95112(b)(3)) should match. If the system is designed to generate more thermal energy than the IPHC applications require, and routine venting or wasting of steam is done before the steam enters the steam-water loop of the IPHC process, the operator must account for the portion of the generated steam that is not actually utilized by the IPHC process. The generated steam that is not utilized is the difference between S_C (section 95112(b)(3)) and S_i (section 95112(a)(5)(C)).

Steam Requirements of the Generation System: A cogeneration system like this may have power augmentation, a de-aerator, NO_x control, or cooling tower (not shown in the diagram or in Table 1) that uses some of the steam generated by the cogeneration system. If the operator includes these steam uses within the system boundary, such that S_C (section 95112(b)(3)) already excludes these steam requirements, the quantity reported under section 95112(a)(5)(B) is zero. On the other hand, if the steam meter is set up in such a way that these system uses are included in the quantity reported under

section 95112(b)(3), the operator must separately calculate these steam uses and report them under section 95112(a)(5)(B). The operator may use an engineering estimate to calculate the steam flows if there are no steam meters to directly measure all the energy flows required by the regulation.

Unit Aggregation and Reporting Tool Configuration: Reporting this system as one configuration is the most straight-forward and efficient way to complete the energy system accounting for both the operator preparing the GHG report and the government agency staff that analyzes the data. There are alternate ways to set up reporting tool configurations that are also acceptable, but are not preferred. One option is to report as two configurations: one includes the combustion turbine generator A, HRSG A, and the portion of steam turbine generator C allocated to generator-HRSG A; and a second configuration includes the combustion turbine generator B, HRSG B, and the portion of the steam turbine generator C allocated to generator-HRSG B. If this option is chosen, the operator must allocate the steam input and electricity output of the steam turbine generator to the generator-HRSG sets A and B. The operator may use the fuel input as a proxy for the allocation or any other operational parameters that may provide a reasonable engineering estimation. The operator would draw two red dashed-line boxes and identify all the arrows that cross each box to determine the energy quantities that need to be reported under section 95112(b).

Another option is to report as three configurations: one includes the combustion turbine generator A and HRSG A; another includes the combustion turbine generator B and HRSG B; and a third configuration includes the steam turbine generator C. If this option is chosen, the operator would report zero total thermal output for generator-HRSG A and generator-HRSG B (because the steam output from the generator-HRSG is not used for any IPHC applications that are not electricity generation), and report zero fuel use for steam turbine generator. However, this option is not preferred because it complicates the energy accounting exercise for the reporter and increases the likelihood of making reporting errors.

Table 1 shows a mapping of the energy flows in and out of the system boundary with the data items required by sections 95112(a) and (b).

Table 1. Example 1- Mapping of Energy Flows to the Required Data

Section 95112	Item Description	Quantity
(a)(4)(A)	Generated electricity provided to wholesale (grid)	$E_{\text{wholesale}}$
(a)(4)(B)	Generated electricity provided or sold directly to particular end-user	0
(a)(4)(C)	Generated electricity used by on-site industrial processes or operations that are neither in support of or a part of the power generation system	E_I
(a)(5)(A)	Generated thermal energy provided or sold to particular end-user	0
(a)(5)(B)	Generated thermal energy for supporting power production	0 [Note 1]
(a)(5)(C)	Generated thermal energy used by on-site industrial processes or operations (exclude any wasted energy)	S_I
(b)(2)	Gross generation	$E_A + E_B + E_C$
(b)(2)	Net generation	$E_N = (E_A + E_B + E_C) - E_P$
(b)(3)	Total thermal output	S_C
(b)(4)	Fuel consumption by fuel type	$F_A + F_B + F_{S-A} + F_{S-B}$ [Note 2]
(b)(7)	Supplemental firing (in percentage of total fuels combusted in this configuration)	$(F_{S-A} + F_{S-B}) / (F_A + F_B + F_{S-A} + F_{S-B})$ [Note 2]
(b)(8)	Other heat input	0
Section 95104	Item Description	Quantity
(d)(1)	Electricity purchases or acquisition	$E_{\text{purchased}}$
(d)(2)	Thermal energy purchases or acquisition	0
(d)(3)	Electricity provided or sold. (Sections 95112(a)(4)(A) and (a)(4)(B) satisfy this requirement.)	See section 95112(a) requirements
(d)(4)	Cogeneration/ bigeneration thermal energy provided or sold. (Section 95112(a)(5)(A) satisfies this requirement.)	0
(d)(4)	Non-cogen/bigen thermal energy provided or sold	0

Notes:

1. For alternate ways to report this quantity, see the Steam Requirements of the Generation System paragraph of this example and the Steam Requirements for Supporting Electricity Generation System sub-section of Section 2 of this document.
2. See the Reporting of Supplemental Firing Information sub-section of Section 2 of this document.

Example 2. A Cogeneration System with Boilers That Also Contribute to Electricity Generation

Facility Boundary

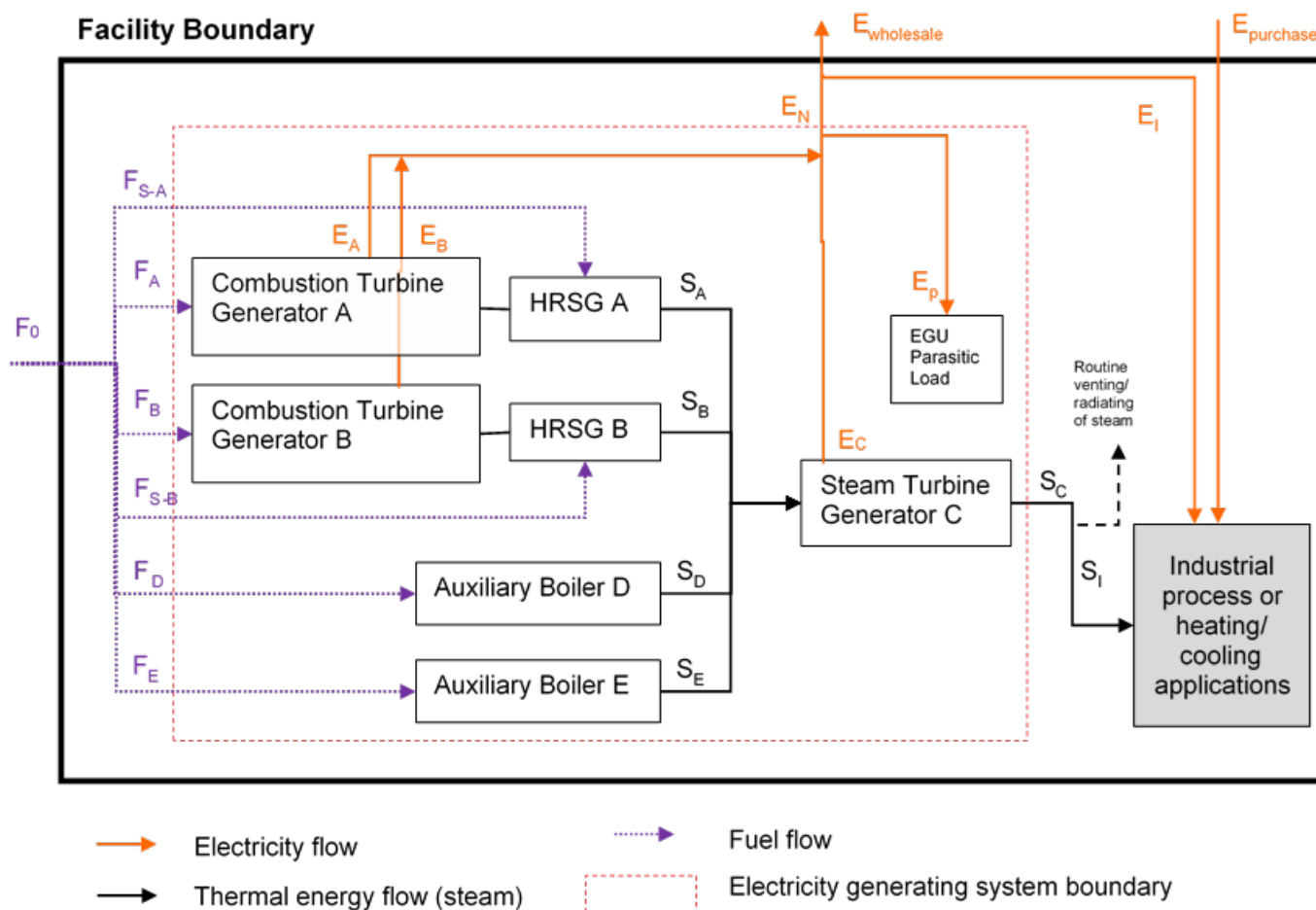

Note: In the interest of presenting a more legible graphical illustration of an energy system analysis, this diagram does not show the location of fuel measurement devices and other equipment that may be associated with the system. Therefore, the diagram as shown does not meet all the requirements of section 95112(a)(6) for a simplified block diagram.

This example shows a cogeneration facility that is an *industrial/institution/ commercial facility with electricity generation capacity* (sections 95112(a)(3) and 95102(a)). The facility includes two combustion turbine generators with HRSG and two boilers that produce steam to power a steam turbine generator. This example is similar to Example 1 except that the steam generated by the two auxiliary boilers also feeds into the steam turbine generator, making the boilers an integral part of the cogeneration system.

System Boundary: The cogeneration system boundary is drawn to include the two combustion turbine generators, the two HRSGs, the two auxiliary boilers, and the steam turbine generator, as shown by the red dashed-line box. To identify energy quantities reported under section 95112(b), look for any arrows that cross the red dashed-line (F_{S-A} , F_A , F_B , F_{S-B} , F_D , F_E , S_C , and E_N which is the net generation). Arrows that do not cross

the system boundary (S_A , S_B , S_D , S_E , and E_p), should not be reported under section 95112(b) because doing so would result in double counting of energy flows in the system. However, E_p is indirectly accounted for in section 95112(b)(2) by the reporting of gross generation net generation, which is the sum of gross generation from the three generators (E_A , E_B , and E_C) minus the parasitic load of the electricity generating system (E_p).

Facility-Level Energy Input-Output: The energy quantities reported under section 95112(a) account for the dispositions of the generated energy. In this example, some of the electricity generated by the cogeneration system is sold to a retail provider or electricity marketer who distributes the electricity over the grid (section 95112(a)(4)(A)), and some of the generated electricity is used for on-site IPHC applications (section 95112(a)(4)(C)). This facility does not sell generated electricity to another "particular end-user" facility (as defined in section 95102(a)). Therefore, the quantity reported under section 95112(a)(4)(B) is zero.

Thermal Output: All the steam generated by this cogeneration system is used for the on-site IPHC applications within the facility boundary. If this system is designed to match the steam demand of the IPHC applications, such that there is no routine venting, radiating, wasting, or discharging of the generated steam, S_i (section 95112(a)(5)(C)) and S_c (section 95112(b)(3)) should match. If the system is designed to generate more thermal energy than the IPHC applications require, and routine venting or wasting of steam is done before the steam enters the steam-water loop of the IPHC process, the operator must account for the portion of the generated steam that is not actually utilized by the IPHC process. The generated steam that is not utilized is the difference between S_c (section 95112(b)(3)) and S_i (section 95112(a)(5)(C)).

Steam Requirements of the Generation System: A cogeneration system like this may have power augmentation, a de-aerator, NO_x control, or cooling tower (not shown in the diagram or in Table 2) that uses some of the steam generated by the cogeneration system. If the operator includes these steam uses within the system boundary, such that S_c (section 95112(b)(3)) already excludes these steam requirements, the quantity reported under section 95112(a)(5)(B) is zero. On the other hand, if the steam meter is set up in such a way that these system uses are included in the quantity reported under section 95112(b)(3), the operator must separately calculate these steam uses and report them under section 95112(a)(5)(B). The operator may use an engineering estimate to calculate the steam flows if there are no steam meters to directly measure all the energy flows required by the regulation.

Unit Aggregation and Reporting Tool Configuration: Reporting this system as one configuration is the most straight-forward and efficient way to complete the energy

system accounting for both the operator preparing the GHG report and the government agency staff that analyzes the data. There are alternate ways to set up reporting tool configurations that are also acceptable, but are not preferred. One option is to report as three configurations: one includes the combustion turbine generator A, HRSG A, and the portion of steam turbine generator C allocated to generator-HRSG A; a second configuration includes the combustion turbine generator B, HRSG B, and the portion of the steam turbine generator C allocated to generator-HRSG B; and a third configuration includes the two auxiliary boilers and the portion of the steam turbine generator C allocated to the auxiliary boilers. If this option is chosen, the operator must allocate the steam input and electricity output of the steam turbine generator to generator-HRSG A, generator-HRSG B, and Auxiliary Boilers D+E. The operator would draw three red dashed-line boxes and identify all the arrows that cross the box to determine the energy quantities that need to be reported under section 95112(b).

Another option is to report as four configurations: one includes the combustion turbine generator A and HRSG A; a second configuration includes the combustion turbine generator B and HRSG B; a third configuration includes Auxiliary Boilers D and E; and a fourth configuration includes the steam turbine generator. If this option is chosen, the operator would report zero total thermal output for generator-HRSG A, generator-HRSG B, Boiler D, and Boiler E (because S_A , S_B , S_D , and S_E are not being used for other IPHC applications that are not electricity generation), report zero fuel use for steam turbine generator, and report the steam extracted from the steam turbine generator as the total thermal output. This option is not preferred because it complicates the energy accounting exercise for the reporter and increases the likelihood of making reporting errors.

Table 2 shows the mapping of the energy flows in and out of the system boundary with the data items required by sections 95112(a) and (b).

Table 2. Example 2- Mapping of Energy Flows to the Required Data

Section 95112	Item Description	Quantity
(a)(4)(A)	Generated electricity provided to wholesale (grid)	$E_{\text{wholesale}}$
(a)(4)(B)	Generated electricity provided or sold directly to particular end-user	0
(a)(4)(C)	Generated electricity used by on-site industrial processes or operations that are neither in support of or a part of the power generation system	E_I
(a)(5)(A)	Generated thermal energy provided or sold to particular end-user	0
(a)(5)(B)	Generated thermal energy for supporting power production	0 [Note 1]
(a)(5)(C)	Generated thermal energy used by on-site industrial processes or operations (exclude any wasted energy)	S_I
(b)(2)	Gross generation	$E_A + E_B + E_C$
(b)(2)	Net generation	$E_N = (E_A + E_B + E_C) - E_P$
(b)(3)	Total thermal output	S_C
(b)(4)	Fuel consumption by fuel type	$F_A + F_B + F_{S-A} + F_{S-B} + F_D + F_E$ [Note 2]
(b)(7)	Supplemental firing (in percentage of total fuels combusted in this configuration)	$(F_{S-A} + F_{S-B}) / (F_A + F_B + F_{S-A} + F_{S-B} + F_D + F_E)$ [Note 2]
(b)(8)	Other heat input	0
Section 95104	Item Description	Quantity
(d)(1)	Electricity purchases or acquisition	$E_{\text{purchased}}$
(d)(2)	Thermal energy purchases or acquisition	0
(d)(3)	Electricity provided or sold. (Sections 95112(a)(4)(A) and (a)(4)(B) satisfy this requirement.)	Same as section 95112(a) requirements
(d)(4)	Cogeneration/ bigeneration thermal energy provided or sold. (Section 95112(a)(5)(A) satisfies this requirement.)	0
(d)(4)	Non-cogen/bigen thermal energy provided or sold	0

Notes:

1. For alternate ways to report this quantity, see the Steam Requirements of the Generation System paragraph of this example and the Steam Requirements for Supporting Electricity Generation System sub-section of Section 2 of this document.
2. See the Reporting of Supplemental Firing Information sub-section of Section 2 of this document.

Example 3a. An Independently Operated Cogeneration Facility with a Thermal Host (Aggregated)

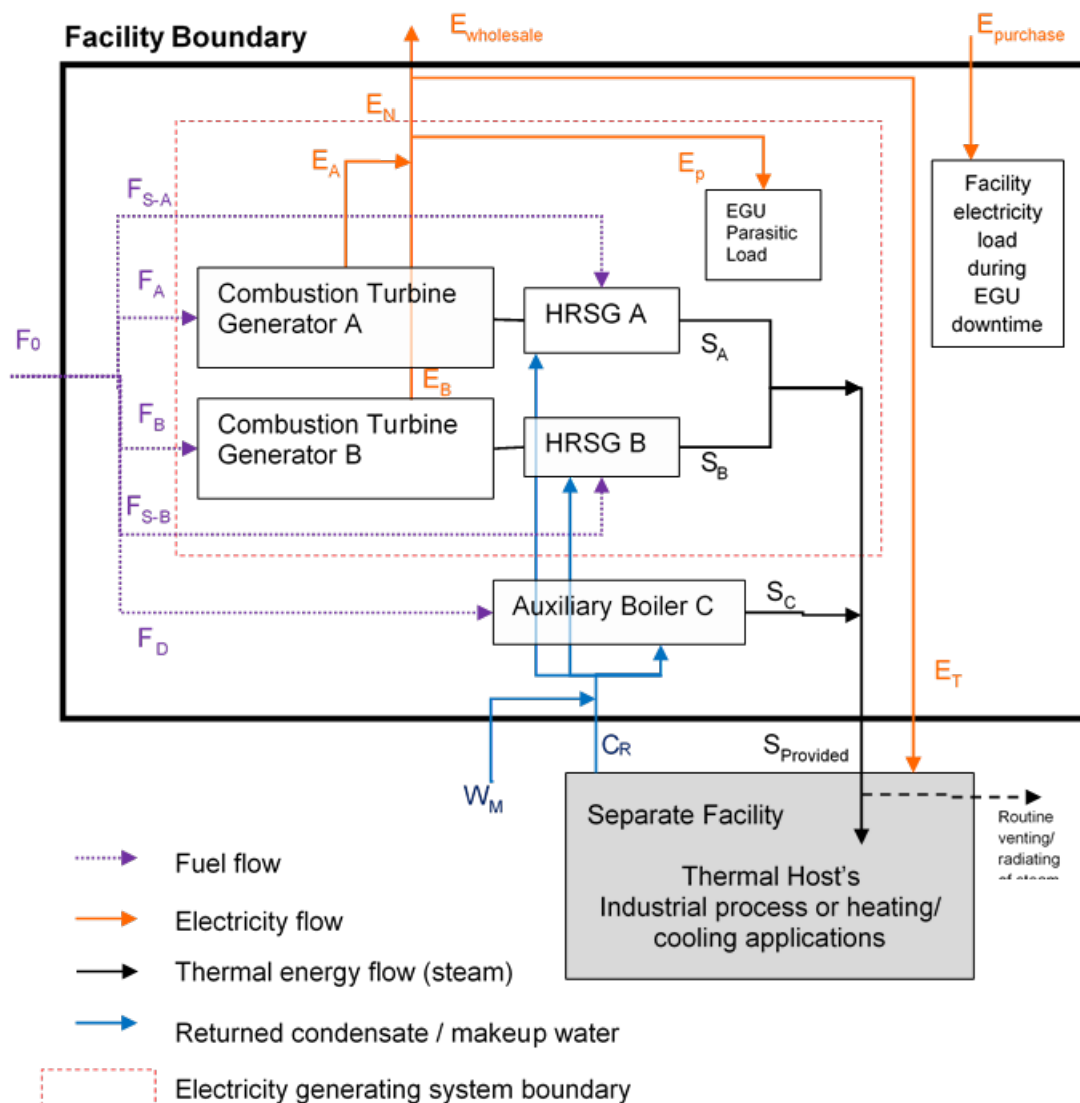

Note: In the interest of presenting a more legible graphical illustration of an energy system analysis, this diagram does not show the location of fuel measurement devices and other equipment that may be associated with the system. Therefore, the diagram as shown does not meet all the requirements of section 95112(a)(6) for a simplified block diagram.

Facility Boundary: This example shows a cogeneration facility that may be either an independently operated cogeneration facility co-located with the thermal host or an independently operated and sited cogeneration facility (sections 95112(a)(3); 95102(a)). For either case, because the facility boundary does not include the thermal host, the operator would account for the energy input and output the same regardless of whether the cogeneration facility is within the same physical fence line on contiguous or adjacent property as the thermal host, or located near the thermal host on non-contiguous or non-adjacent property. For an independently operated cogeneration facility co-located

with the thermal host, the cogeneration facility must have no common operational control and no common ownership as the thermal host. If there is common operational control OR common ownership, OR both, the cogeneration facility and the thermal host must be pulled into the same facility boundary.

The facility in this example includes two combustion turbine generators, each with a HRSG that produces steam for the thermal host. The facility also has an auxiliary boiler to supply additional steam to the thermal host if the cogeneration system does not generate enough steam to meet the thermal host's steam demand. Because the auxiliary boiler is not a part of the electricity generation system, it must be reported separately.

System Boundary: The cogeneration system boundary is drawn to include the two combustion turbine generators and their HRSGs, as shown by the red dashed-line box. To identify energy quantities to be reported under section 95112(b), look for any arrows that cross the red dashed-line (F_{S-A} , F_A , F_B , F_{S-B} , the sum of S_A and S_B , and E_N which is the net generation). Arrows that do not cross the system boundary (e.g., E_p), should not be reported under section 95112(b) because doing so would result in double counting of energy flows of the system. However, E_p is indirectly accounted for in section 95112(b)(2) by the reporting of net generation, which is the sum of gross generation from the two generators (E_A and E_B) minus the parasitic load of the electricity generating system (E_p).

Facility-Level Energy Input-Output: The energy quantities reported under section 95112(a) account for the dispositions of the generated energy. In this example, some of the electricity generated by the cogeneration system is sold to a retail provider or electricity marketer who distributes the electricity over the grid (section 95112(a)(4)(A)), and some of the generated electricity is provided or sold to the thermal host ("particular end user," sections 95112(a)(4)(B) and 95102(a)). Within this facility's boundary, there is no on-site industrial process or operations that are either in support of or a part of the power generation system. Therefore, the quantity specified in section 95112(a)(4)(C) is zero.

Thermal Output: All the steam generated by this cogeneration system is sent to the thermal host. If this system is designed to match the steam demand of the thermal host, such that there is no routine venting, radiating, wasting, or discharging of the generated steam, the operator may report the sum of S_A and S_B as the quantities reported under both sections 95112(b)(3) and 95112(a)(5)(A). If the system is designed to generate more thermal energy than the thermal host requires, and the cogeneration operator must routinely vent, waste, or discharge steam before sending the steam to the thermal host (not as shown in the diagram), the operator must account for the portion of

the generated steam that is wasted, which is the difference the cogeneration steam provided/sold (section 95112(a)(5)(A)) and the sum of S_A and S_B (section 95112(b)(3)). However, if the routine venting, wasting, and discharged of the steam is done by the thermal host and outside of the control of the cogeneration facility operator (as shown in the diagram), the operator does not need to account for the wasted steam in its GHG report, and may report the sum of S_A and S_B as the quantities reported under both sections 95112(b)(3) and 95112(a)(5)(A).

Steam Requirements of the Generation System: A cogeneration system like this may have a de-aerator, NO_x control, or cooling tower that uses some of the steam generated by the cogeneration system (not shown in the diagram). If the operator includes these cogeneration system steam requirements within the system boundary, such that the sum of S_A and S_B (section 95112(b)(3)) that crosses the system boundary already excludes the system steam requirements, the quantity reported under section 95112(a)(5)(B) is zero. On the other hand, if the steam meter is set up in such a way that the system steam requirements are included in the total thermal output quantity reported under section 95112(b)(3), the operator must separately calculate the system steam requirements and report them under section 95112(a)(5)(B). This way the three quantities reported under section 95112(a)(5) corroborate the total thermal output quantity reported under section 95112(b)(3). The operator may use an engineering estimate to calculate the steam flows if there are no steam meters to directly measure all the energy flows required by the regulation.

Returned Condensate: This cogeneration system receives returned condensate from the thermal host. To avoid double counting of the energy in the steam-water loop of the system, the enthalpy of the generated steam (S_A and S_B) should not include the enthalpy of the returned condensate and any makeup water added to the HRSG feedwater. The operator can exclude the enthalpy of the feedwater into the boiler and the HRSGs by simply using the temperature of the feedwater as the reference temperature for the enthalpy calculation of the generated steam (S_A and S_B). If the steam meters and the computerized data acquisition system are set up such that the reference temperature of the generated steam is different from the temperature of the returned condensate, the operator must make an adjustment calculation when reporting total thermal output.

Table 3a shows the mapping of the energy flows in and out of the system boundary with the data items required by sections 95112(a) and (b).

Table 3a. Example 3a- Mapping of Energy Flows to the Required Data

Section 95112	Item Description	Quantity
(a)(4)(A)	Generated electricity provided to wholesale (grid)	$E_{\text{wholesale}}$
(a)(4)(B)	Generated electricity provided or sold directly to a particular end-user	E_T
(a)(4)(C)	Generated electricity used by on-site industrial processes or operations that are neither in support of or a part of the power generation system	0
(a)(5)(A)	Generated thermal energy provided or sold to particular end-user	$S_A + S_B$
(a)(5)(B)	Generated thermal energy for supporting power production	0 [Note 1]
(a)(5)(C)	Generated thermal energy used by on-site industrial processes or operations (exclude any wasted energy)	0
(b)(2)	Gross generation	$E_A + E_B$
(b)(2)	Net generation	$E_N = (E_A + E_B) - E_P$
(b)(3)	Total thermal output	$S_A + S_B$
(b)(4)	Fuel consumption by fuel type	$F_A + F_B + F_{S-A} + F_{S-B}$ [Note 2]
(b)(7)	Supplemental firing (in percentage of total fuels combusted in this configuration)	$(F_{S-A} + F_{S-B}) / (F_A + F_B + F_{S-A} + F_{S-B})$ [Note 2]
(b)(8)	Other heat input	0
Section 95104	Item Description	Quantity
(d)(1)	Electricity purchases or acquisition	$E_{\text{purchased}}$
(d)(2)	Thermal energy purchases or acquisition	0
(d)(3)	Electricity provided or sold. (Sections 95112(a)(4)(A) and (a)(4)(B) satisfy this requirement.)	Same as section 95112(a) requirements
(d)(4)	Cogeneration/ bigeneration thermal energy provided or sold. (Section 95112(a)(5)(A) satisfies this requirement.)	$S_A + S_B$
(d)(4)	Non-cogen/bigeneration thermal energy provided or sold	S_C

Notes:

1. For alternate ways to report this quantity, see the Steam Requirements of the Generation System paragraph of this example and the Steam Requirements for Supporting Electricity Generation System sub-section of Section 2 of this document.
2. See the Reporting of Supplemental Firing Information sub-section of Section 2 of this document.

Example 3b. An Independently Operated Cogeneration Facility with a Thermal Host (Disaggregated)

In Example 3a, the two combustion turbine generators and HRSGs have been combined into one system. Alternately, the operator may also report them as two separate configurations in the reporting tool. (In contrast to Examples 1 and 2, where there is a steam turbine generator that makes disaggregated reporting complicated, unit disaggregation can be easily done in a cogeneration system without a steam turbine generator, such as in this example.) Example 3b shows the system boundary of disaggregated reporting configurations, and Table 3b enumerates the mapping of the energy flows to the reporting requirements.

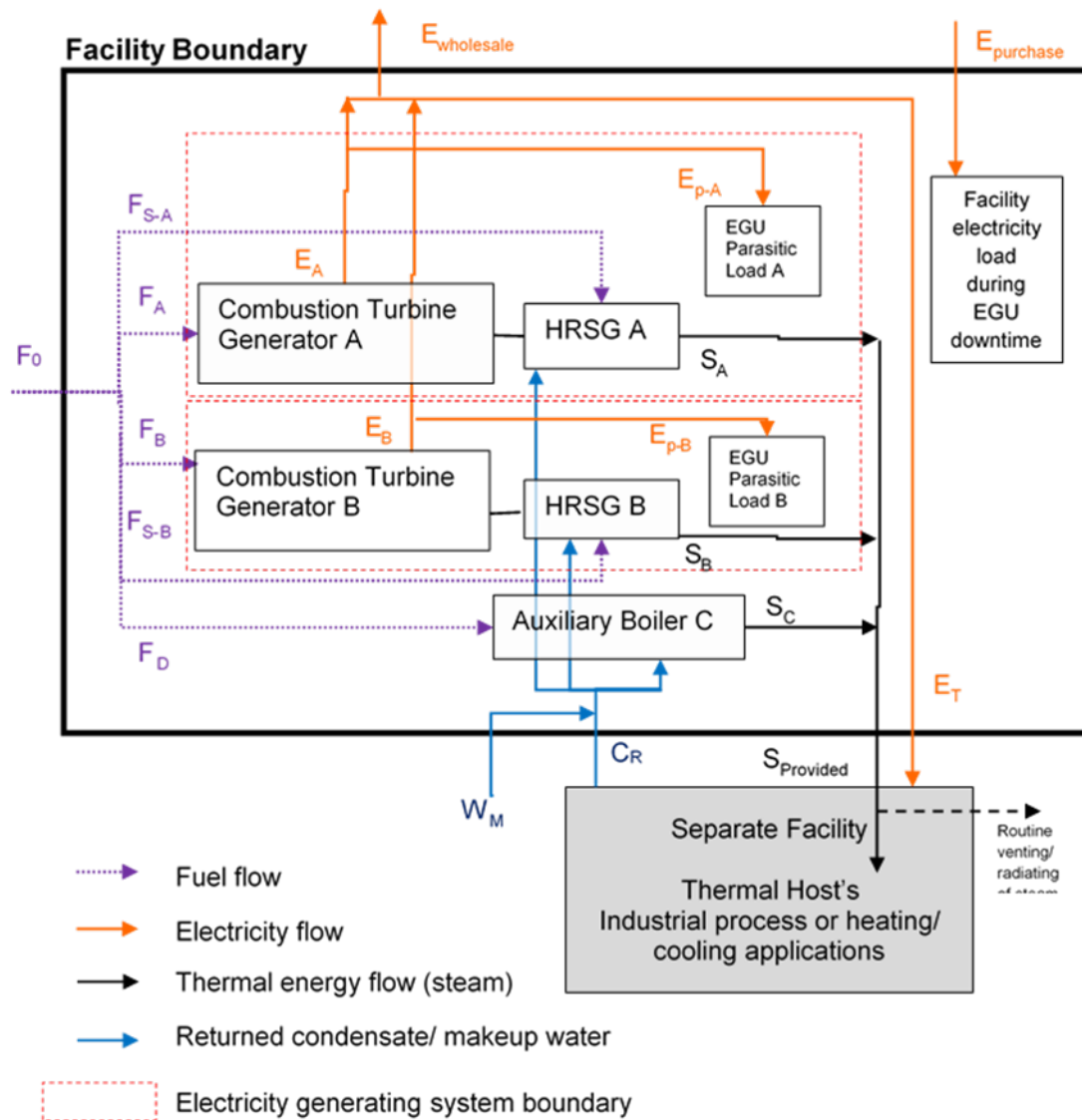

Note: In the interest of presenting a more legible graphical illustration of an energy system analysis, this diagram does not show the location of fuel measurement devices and other equipment that may be associated with the system. Therefore, the diagram as shown does not meet all the requirements of section 95112(a)(6) for a simplified block diagram.

Table 3b. Example 3b- Mapping of Energy Flows to the Required Data

Section 95112	Item Description	Quantity
(a)(4)(A)	Generated electricity provided to wholesale (grid)	$E_{\text{wholesale}}$
(a)(4)(B)	Generated electricity provided or sold directly to a particular end-user	E_T
(a)(4)(C)	Generated electricity used by on-site industrial processes or operations that are neither in support of or a part of the power generation system	0
(a)(5)(A)	Generated thermal energy provided or sold to particular end-user	$S_A + S_B$
(a)(5)(B)	Generated thermal energy for supporting power production	0 [Note 1]
(a)(5)(C)	Generated thermal energy used by on-site industrial processes or operations (exclude any wasted energy)	0
	Unit Configuration A (Generator A + HRSG A):	
(b)(2)	Gross generation	E_A
(b)(2)	Net generation	$E_A - E_{p-A}$ [Note 2]
(b)(3)	Total thermal output	S_A
(b)(4)	Fuel consumption by fuel type	$F_A + F_{S-A}$ [Note 3]
(b)(7)	Supplemental firing (in percentage of total fuels combusted in this configuration)	$F_{S-A} / (F_A + F_{S-A})$ [Note 3]
(b)(8)	Other heat input	0
	Unit Configuration B (Generator B + HRSG B):	
(b)(2)	Gross generation	E_B
(b)(2)	Net generation	$E_B - E_{p-B}$ [Note 2]
(b)(3)	Total thermal output	S_B
(b)(4)	Fuel consumption by fuel type	$F_B + F_{S-B}$ [Note 3]
(b)(7)	Supplemental firing (in percentage of total fuels combusted in this configuration)	$F_{S-B} / (F_B + F_{S-B})$ [Note 3]
(b)(8)	Other heat input	0
Section 95104	Item Description	Quantity
(d)(1)	Electricity purchases or acquisition	$E_{\text{purchased}}$
(d)(2)	Thermal energy purchases or acquisition	0
(d)(3)	Electricity provided or sold. (Sections 95112(a)(4)(A) and (a)(4)(B) satisfy this requirement.)	Same as section 95112(a) requirements
(d)(4)	Cogeneration/ bigeneration thermal energy provided or sold. (Section 95112(a)(5)(A) satisfies this requirement.)	$S_A + S_B$
(d)(4)	Non-cogen/bigen thermal energy provided or sold	S_C

Notes:

1. For alternate ways to report this quantity, see the Steam Requirements of the Generation System paragraph of this example and the Steam Requirements for Supporting Electricity Generation System sub-section of Section 2 of this document.
2. If there are no meters for measuring the parasitic load of the individual units, it is acceptable to use an engineering estimation method.
3. See the Reporting of Supplemental Firing Information sub-section of Section 2 of this document.

Example 4. A Biggeration Facility

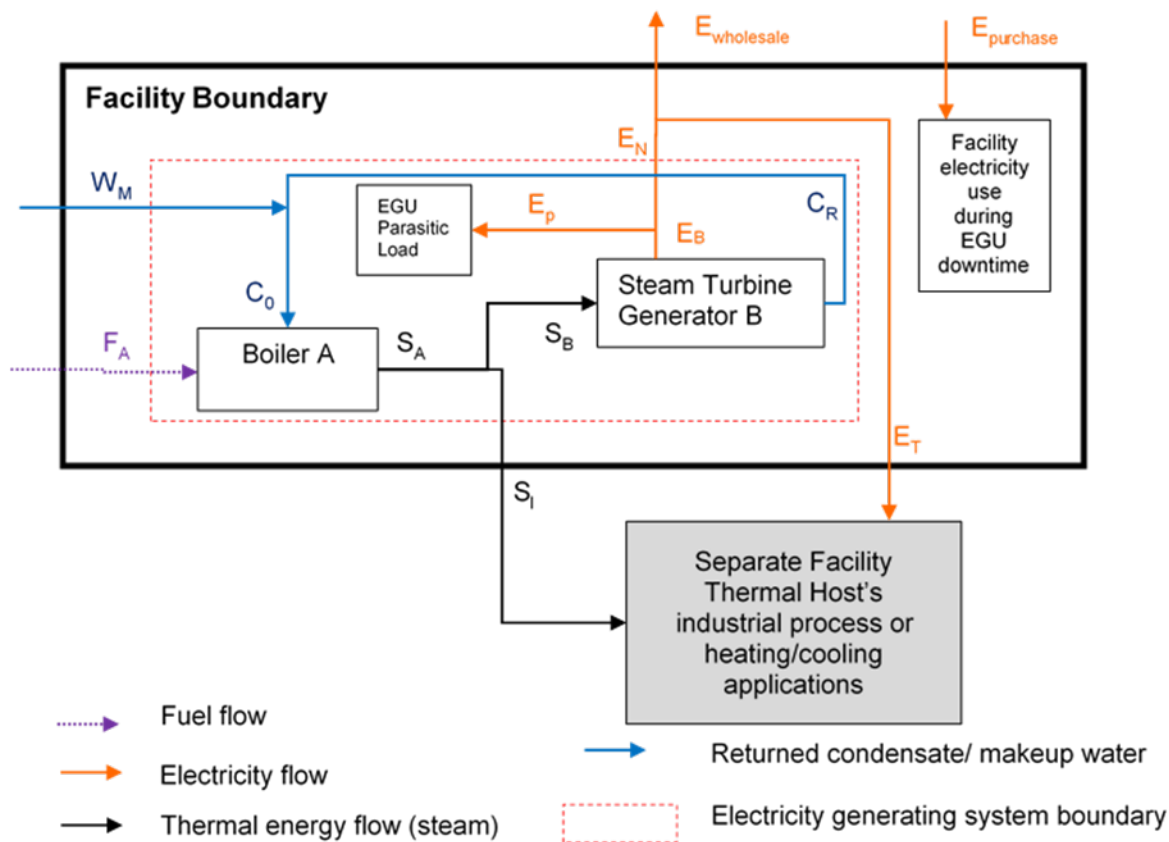

Note: In the interest of presenting a more legible graphical illustration of an energy system analysis, this diagram does not show the location of fuel measurement devices and other equipment that may be associated with the system. Therefore, the diagram as shown does not meet all the requirements of section 95112(a)(6) for a simplified block diagram.

Facility Boundary: This example shows a biggeration facility that may be either an independently operated biggeration facility co-located with the thermal host or an independently operated and sited biggeration facility (sections 95112(a)(3) and 95102(a)). For either case, because the facility boundary does not include the thermal host, the operator would account for the energy input and output the same regardless of whether the cogeneration facility is within the same physical fence line on contiguous or adjacent property as the thermal host, or located near the thermal host on non-contiguous or non-adjacent property. For an independently operated biggeration facility co-located with the thermal host, the biggeration facility must have no common operational control and no common ownership as the thermal host. If there is common operational control OR common ownership, OR both, the biggeration facility and the thermal host must be pulled into the same facility boundary.

The facility in this example includes a boiler and a steam turbine generator. The steam generated by the boiler is split into two streams, one stream feeds the steam turbine

generator (S_B) and the other stream is provided or sold to the thermal host (S_i). The steam condenses after it is utilized at the steam turbine generator B, and the condensate (C_R) is returned to the boiler with additional makeup water (W_M) acquired from outside of the facility boundary.

System Boundary: The bigeneration system boundary is drawn to include the boiler and the steam turbine generator, as shown by the red dashed-line box. To identify energy quantities to be reported under section 95112(b), look for any arrows that cross the red dashed-line (F_A , S_i , and E_N which is the net generation). Arrows that do not cross the system boundary (e.g., S_A , S_B , E_p and C_R), should not be reported under section 95112(b) because doing so would result in double counting of energy flows of the system. However, E_p is indirectly accounted for in section 95112(b)(2) by the reporting of net generation, which is the gross generation (E_B) minus the parasitic load of the electricity generating system (E_p). Also C_R and W_M are implied in the calculations of steam input to the steam turbine (S_B) and the output of the heat recovery steam generator (S_A), as the enthalpy of the boiler feedwater must be excluded from the boiler steam output. See the *Returned Condensate* discussion below for additional information.

Facility-Level Energy Input-Output: The energy quantities reported under section 95112(a) account for the dispositions of the generated energy. In this example, some of the electricity generated by the cogeneration system is sold to a retail provider or electricity marketer who distributes the electricity over the grid (section 95112(a)(4)(A)), and some of the generated electricity is provided or sold to the thermal host ("particular end user," sections 95112(a)(4)(B) and 95102(a)). Within this facility's boundary, there is no electricity used for on-site industrial process or operations that are not in support of or a part of the power generation system. Therefore, the quantity specified in section 95112(a)(4)(C) is zero.

Returned Condensate: The returned condensate from the steam turbine generator (C_R) is mixed with makeup water from outside of the facility boundary (W_M) to provide the feedwater for the boiler (C_0). To avoid double counting of the energy in the steam-water loop of the system, the enthalpy of the generated steam (S_A , S_B , and S_i) should not include the enthalpy of the boiler feedwater (C_0). The operator can exclude the enthalpy of the boiler feedwater by simply using the temperature of the feedwater as the reference temperature for the enthalpy calculation of the generated steam. If the steam meter and the computerized data acquisition system are set up such that the reference temperature of the generated steam is different from the temperature of the feedwater, the operator must make an adjustment calculation when reporting the thermal energy quantities.

Guidance for California’s Mandatory Greenhouse Gas Emissions Reporting

Table 4 shows the mapping of the energy flows in and out of the system boundary with the data items required by sections 95112(a) and (b).

Table 4. Example 4- Mapping of Energy Flows to the Required Data

Section 95112	Item Description	Quantity
(a)(4)(A)	Generated electricity provided to wholesale (grid)	$E_{\text{wholesale}}$
(a)(4)(B)	Generated electricity provided or sold directly to a particular end-user	E_T
(a)(4)(C)	Generated electricity used by on-site industrial processes or operations that are neither in support of or a part of the power generation system	0
(a)(5)(A)	Generated thermal energy provided or sold to particular end-user	S_I
(a)(5)(B)	Generated thermal energy for supporting power production	0 [Note 1]
(a)(5)(C)	Generated thermal energy used by on-site industrial processes or operations (exclude any wasted energy)	0
(b)(2)	Gross generation	E_B
(b)(2)	Net generation	$E_N = E_B - E_P$
(b)(3)	Total thermal output	S_I
(b)(4)	Fuel consumption by fuel type	F_A
(b)(7)	Supplemental firing (in percentage of total fuels combusted in this configuration)	0
(b)(8)	Other heat input	0
Section 95104	Item Description	Quantity
(d)(1)	Electricity purchases or acquisition	$E_{\text{purchased}}$
(d)(2)	Thermal energy purchases or acquisition	0
(d)(3)	Electricity provided or sold. (Sections 95112(a)(4)(A) and (a)(4)(B) satisfy this requirement.)	Same as section 95112(a) requirements
(d)(4)	Cogeneration/ bigeneration thermal energy provided or sold. (Section 95112(a)(5)(A) satisfies this requirement.)	S_I
(d)(4)	Non-cogen/bigen thermal energy provided or sold	0

Notes:

1. For alternate ways to report this quantity, see the Steam Requirements of the Generation System paragraph of this example and the Steam Requirements for Supporting Electricity Generation System sub-section of Section 2 of this document.

Example 5. A Bottoming Cycle Cogeneration Facility

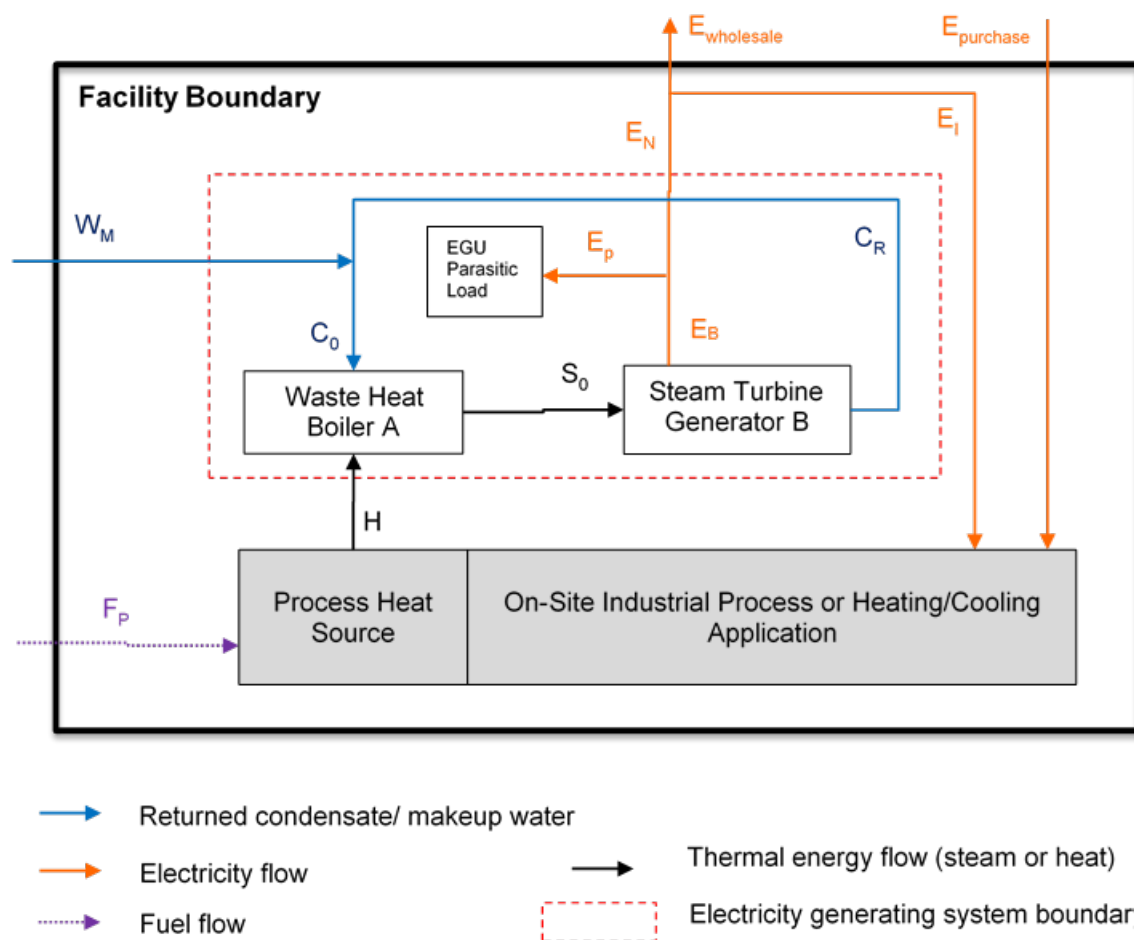

Note: In the interest of presenting a more legible graphical illustration of an energy system analysis, this diagram does not show the location of fuel measurement devices and other equipment that may be associated with the system. Therefore, the diagram as shown does not meet all the requirements of section 95112(a)(6) for a simplified block diagram.

Facility Boundary: This example shows a bottoming cycle cogeneration facility in an *industrial/institutional/commercial facility with electricity generation capacity* (sections 95112(a)(3) and 95102(a)). The cogeneration system generates steam from the waste heat of the industrial process, and the steam generated by the waste heat boiler powers a steam turbine generator for electricity generation.

System Boundary: The cogeneration system boundary includes the waste heat boiler and the steam turbine generator, as shown by the red dashed-line box. To identify energy quantities reported under section 95112(b), look for any arrows that cross the red dashed-line (H and E_N which is the net generation). With the exception of S_0 , which is explicitly required to be reported in section 95112(b)(8) and will not be double counted in energy analysis, arrows that do not cross the system boundary (e.g., C_R , and E_p), should not be reported under section 95112(b) because doing so would result in

double counting of energy flows of the system. However, E_p is indirectly accounted for in section 95112(b)(2) by the reporting of net generation, which is the gross generation (E_B) minus the parasitic load of the electricity generating system (E_p). Also, C_R and W_M are implied in the calculation of the output of the heat recovery steam generator (S_0) and the steam input to the steam turbine (S_0) (section 95112(b)(8)). See the *Returned Condensate* section in Section 2 of this guidance document for additional information.

Facility-Level Energy Input-Output: The energy quantities reported under section 95112(a) account for the dispositions of the generated energy. In this example, some of the electricity generated by the cogeneration system is sold to a retail provider or electricity marketer who distributes the electricity over the grid (section 95112(a)(4)(A)), and some of the generated electricity is used for on-site IPHC applications (section 95112(a)(4)(C)). This facility does not sell generated electricity to another "particular end-user" facility (as defined in section 95102(a)). Therefore, the section 95112(a)(4)(B) quantity is zero.

Thermal Output and Steam Requirements of the Generation System: In the diagram and accompanying Table 5 for this example, there is no total thermal output from this bottoming cycle cogeneration system because the system does not output steam for non-electricity-generation applications. In a scenario where some steam is extracted from the waste heat boiler or steam turbine and is utilized in on-site IPHC application, the operator must report the extracted steam as total thermal output (section 95112(b)(3)). (Note this scenario is not illustrated in the diagram or in Table 5.)

If the facility has a de-aerator or cooling tower that uses some of the steam generated by the cogeneration system (not shown in the diagram and not shown in Table 5), the operator must account for the steam use. The operator has two options for accounting for the steam: (1) If the operator considers the de-aerator or cooling tower a part of the bottoming cycle cogeneration system (i.e., the steam used for those purposes stays within the system boundary) the operator does not need to explicitly account for the energy flows for those uses; (2) If the operator considers the de-aerator or cooling tower not within the cogeneration system boundary, the steam used for de-aerator or cooling tower must be included in the total thermal output quantity (section 95112(b)(3)). In this case, the operator must also separately report the steam use under section 95112(a)(5)(B) so the three quantities reported under section 95112(a)(5)(B) corroborate the total thermal output quantity under section 95112(b)(3). The operator may use an engineering estimate to calculate the steam flows if there are no steam meters to directly measure all the energy flows required by the regulation.

Table 5 shows the mapping of the energy flows in and out of the system boundary with the data items required by sections 95112(a) and (b).

Table 5. Example 5- Mapping of Energy Flows to the Required Data

Section 95112	Item Description	Quantity
(a)(4)(A)	Generated electricity provided to wholesale (grid)	$E_{\text{wholesale}}$
(a)(4)(B)	Generated electricity provided or sold directly to a particular end-user	0
(a)(4)(C)	Generated electricity used by on-site industrial processes or operations that are neither in support of or a part of the power generation system	E_I
(a)(5)(A)	Generated thermal energy provided or sold to particular end-user	0
(a)(5)(B)	Generated thermal energy for supporting power production	0 [Note 1]
(a)(5)(C)	Generated thermal energy used by on-site industrial processes or operations (exclude any wasted energy)	0
(b)(2)	Gross generation	E_B
(b)(2)	Net generation	$E_N = E_B - E_P$
(b)(3)	Total thermal output	0
(b)(4)	Fuel consumption by fuel type	0 [Note 2]
(b)(7)	Supplemental firing (in percentage of total fuels combusted in this configuration)	0 [Note 2]
(b)(8)	Additional heat input that is not already accounted for in section 95112(b)(4)-(6).	H
(b)(8)	Input steam to the steam turbine	S_0
(b)(8)	Output of the heat recovery steam generator	S_0
Section 95104	Item Description	Quantity
(d)(1)	Electricity purchases or acquisition	$E_{\text{purchased}}$
(d)(2)	Thermal energy purchases or acquisition	0
(d)(3)	Electricity provided or sold. (Sections 95112(a)(4)(A) and (a)(4)(B) satisfy this requirement.)	Same as section 95112(a) requirements
(d)(4)	Cogeneration/ bigeneration thermal energy provided or sold. (Section 95112(a)(5)(A) satisfies this requirement.)	0
(d)(4)	Non-cogen/bigen thermal energy provided or sold	0

Notes:

1. For alternate ways to report this quantity, see the Steam Requirements of the Generation System paragraph of this example and the Steam Requirements for Supporting Electricity Generation System sub-section of Section 2 of this document.
2. If the cogeneration system includes supplemental firing, these values should not be zero.

Example 6. A Combined Cycle Power Plant

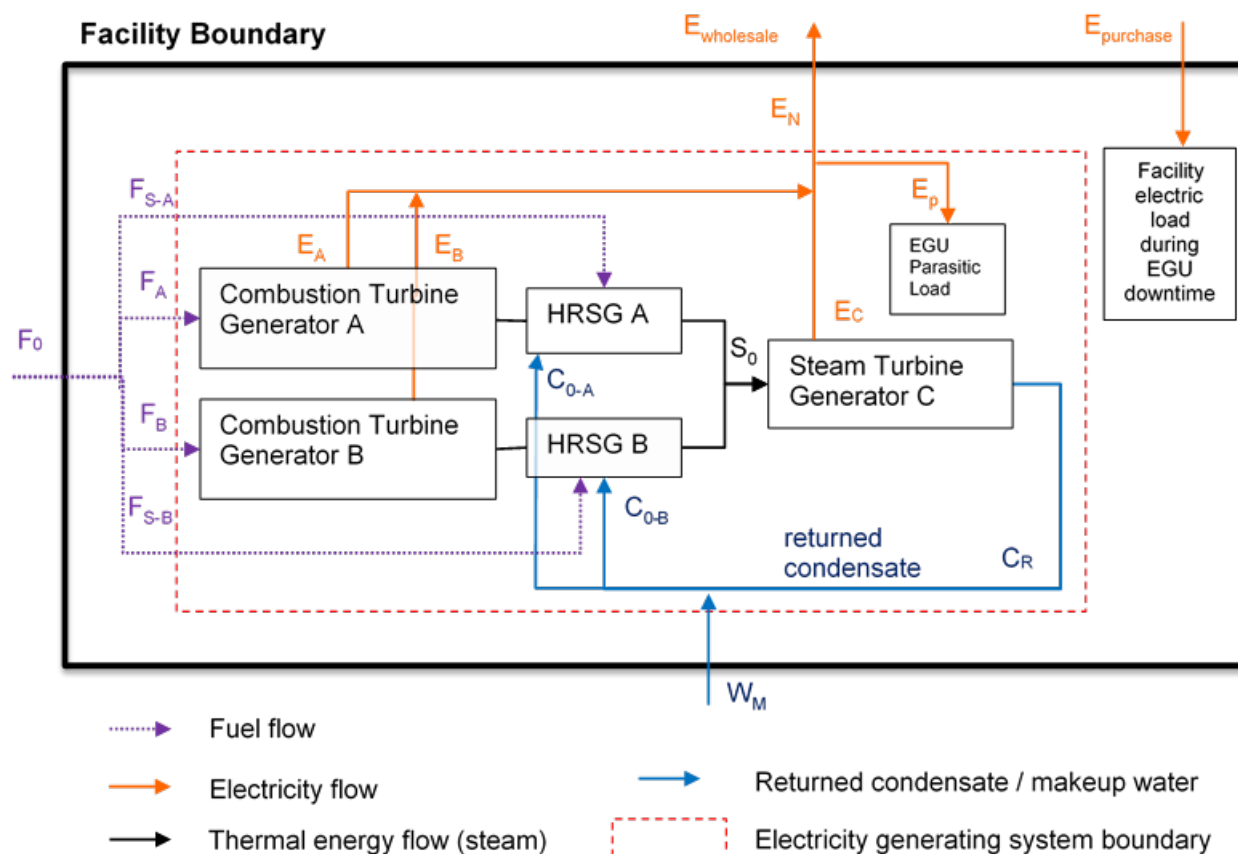

Note: In the interest of presenting a more legible graphical illustration of an energy system analysis, this diagram does not show the location of fuel measurement devices and other equipment that may be associated with the system. Therefore, the diagram as shown does not meet all the requirements of section 95112(a)(6) for a simplified block diagram.

This example shows a *stand-alone electricity generation facility* (sections 95112(a)(3) and 95102(a)) that is a combined cycle power plant. The facility includes two combustion turbine generators, each with a HRSG that produces steam to power a steam turbine generator.

System Boundary: The cogeneration system boundary is drawn to include the two combustion turbine generators, two HRSGs, and the steam turbine generator, as shown by the red dashed-line box. To identify energy quantities to be reported under section 95112(b), look for any arrows that cross the red dashed-line (F_{S-A} , F_A , F_B , F_{S-B} , and E_N which is the net generation). Arrows that do not cross the system boundary (S_0 , C_R , C_{0-A} , C_{0-B} , and E_p), should not be reported under section 95112(b) because doing so would result in double counting of energy flows of the system. However, E_p is indirectly accounted for in section 95112(b)(2) by the reporting of gross generation and net generation, which is the sum of gross generation from the three generators (E_A , E_B , and E_C) minus the parasitic load of the electricity generating system (E_p).

Facility-Level Energy Input-Output: The energy quantities reported under section 95112(a) account for the dispositions of the generated energy. In this example, all of the net electricity generated by the power plant is sold to a retail provider or electricity marketer who distributes the electricity over the grid (section 95112(a)(4)(A)) (a "grid-dedicated facility"). This facility has no on-site IPHC applications (section 95112(a)(4)(C)) and does not sell generated electricity to another "particular end-user" facility (as defined in section 95102(a)). Therefore, the quantities reported under sections 95112(a)(4)(B) and (C) are zero.

Steam Requirements of the Generation System: If the facility has a power augmentation, de-aerator, NO_x control, or cooling tower that uses some of the steam generated by the HRSGs or extracted from the steam turbine (not shown in the diagram or Table 6), the operator may consider those uses as a part of the system. Since those steam uses stay within the system boundary, the operator does not need to explicitly account for the energy flows for those purposes. Therefore, the quantities reported under sections 95112(a)(5)(B) and 95112(b)(3) are zero.

Unit Aggregation and Reporting Tool Configuration: Reporting this system as one configuration is the most straight-forward and efficient way to complete the energy system accounting for both the facility operator preparing the GHG report and the government agency staff that analyzes the data. There are alternate ways to set up reporting tool configurations that are also acceptable, but are not preferred. One option is to report as two configurations: one includes the combustion turbine generator A, HRSG A, and the portion of steam turbine generator C allocated to generator-HRSG A; and a second configuration includes the combustion turbine generator B, HRSG B, and the portion of the steam turbine generator C allocated to generator-HRSG B. If this option is chosen, the operator must allocate the steam input and electricity output of the steam turbine generator to generator-HRSG sets A and B. The operator would draw two red dashed-line boxes and identify all the arrows that cross the box to determine the energy quantities that need to be reported under section 95112(b).

Another option is to report as three configurations: one includes the combustion turbine generator A and HRSG A; another includes the combustion turbine generator B and HRSG B; and a third configuration includes the steam turbine generator. If this option is chosen, the operator would report zero total thermal output for generator-HRSG A and generator-HRSG B (because those thermal output are not being used for other IPHC applications that are not electricity generation), and report zero fuel use for steam turbine generator. This option is not preferred because it complicates the energy accounting exercise for the reporter and increases the likelihood of making reporting errors.

Table 6 shows the mapping of the energy flows in and out of the system boundary with the data items required by sections 95112(a) and (b).

Table 6. Example 6- Mapping of Energy Flows to the Required Data

Section 95112	Item Description	Quantity
(a)(4)(A)	Generated electricity provided to wholesale (grid)	$E_{\text{wholesale}}$
(a)(4)(B)	Generated electricity provided or sold directly to a particular end-user	0
(a)(4)(C)	Generated electricity used by on-site industrial processes or operations that are neither in support of or a part of the power generation system	0
(a)(5)(A)	Generated thermal energy provided or sold to particular end-user	0
(a)(5)(B)	Generated thermal energy for supporting power production	0
(a)(5)(C)	Generated thermal energy used by on-site industrial processes or operations (exclude any wasted energy)	0
(b)(2)	Gross generation	$E_A + E_B + E_C$
(b)(2)	Net generation	$E_N = (E_A + E_B + E_C) - E_P$
(b)(3)	Total thermal output	0
(b)(4)	Fuel consumption by fuel type	$F_A + F_B + F_{S-A} + F_{S-B}$ [Note 1]
(b)(7)	Supplemental firing (in percentage of total fuels combusted in this configuration)	$(F_{S-A} + F_{S-B}) / (F_A + F_B + F_{S-A} + F_{S-B})$
(b)(8)	Other heat input	0
Section 95104	Item Description	Quantity
(d)(1)	Electricity purchases or acquisition	$E_{\text{purchased}}$
(d)(2)	Thermal energy purchases or acquisition	0
(d)(3)	Electricity provided or sold. (Sections 95112(a)(4)(A) and (a)(4)(B) satisfy this requirement.)	Same as section 95112(a) requirements
(d)(4)	Cogeneration/ bigeneration thermal energy provided or sold. (Section 95112(a)(5)(A) satisfies this requirement.)	0
(d)(4)	Non-cogen/bigen thermal energy provided or sold	0

6 Additional Information

Detailed training materials for reporting using Cal e-GGRT: <https://ww2.arb.ca.gov/mrr-tool>.

The GHG Mandatory Reporting Regulation, with full requirements: <https://ww2.arb.ca.gov/mrr-regulation>.

Additional reporting and applicability guidance documents to assist reporters in complying with the MRR: <https://ww2.arb.ca.gov/mrr-guidance>.

Guidance for Aggregation of Emitting Units: <https://www.arb.ca.gov/cc/reporting/ghg-rep/guidance/unit-aggregation.pdf>

Contact the MRR helpdesk: ghgreport@arb.ca.gov.

For help with reporting or verification, please contact the appropriate staff member: <https://ww2.arb.ca.gov/mrr-contacts>.