

– Attachment 7 –

State of California
Air Resources Board

Proposed Amendments to Vapor Recovery Test Procedure TP-201.1D:
Leak Rate of Drop Tube Overfill Prevention Devices
and Spill Container Drain Valves

This Page Intentionally Left Blank



CALIFORNIA
AIR RESOURCES BOARD

Vapor Recovery Test Procedure

TP-201.1D

Leak Rate of Drop Tube Overfill Prevention Devices and Spill Container Drain Valves

Adopted: February 1, 2001

Amended: July 3, 2002

Amended: October 8, 2003

Amended: July 12, 2021

[Note: The proposed text additions are underlined and proposed text deletions are indicated by ~~striketrough~~. [Bracketed text] is not part of the proposed amendments.]

**California Environmental Protection Agency
California Air Resources Board**

Vapor Recovery Test Procedure

TP-201.1D

**Leak Rate of
Drop Tube Overfill Prevention Devices
and Spill Container Drain Valves**

Definitions common to all certification and test procedures are in:

D-200 Definitions for Vapor Recovery Procedures

For the purpose of this procedure, the term "CARB" refers to the California Air Resources Board, and the term "Executive Officer" refers to the CARB Executive Officer, or his or her authorized representative or designate.

1. PURPOSE AND APPLICABILITY

The purpose of this procedure is to quantify the leak rate of overfill prevention devices located in the Phase I product drop tube on two-point Phase I systems. When applicable, this procedure is also used to quantify the leak rate of a spill container drain valve which passes liquid directly into the Phase I drop tube.

This procedure is applicable only to those Gasoline Dispensing Facilities (GDF) equipped with an overfill prevention device located in the Phase I product drop tube. It is used to determine the compliance of components with the performance specification for the maximum allowable leak rate as defined in CP-201 Vapor Recovery Certification Procedure for Vapor Recovery Systems at Gasoline Dispensing Facilities Using Underground Storage Tanks.

2. PRINCIPLE AND SUMMARY OF TEST PROCEDURE

A compatible cap for a Phase I product adaptor is modified to allow the introduction of nitrogen into the Phase I drop tube. A pressure gauge is connected to the modified cap and nitrogen is flowed into the drop tube. If the resulting nitrogen flow rate necessary to maintain a steady-state pressure is less than or equal to the specifications described in CP-201, the overfill prevention device is verified to be in compliance. In the case where a spill container drain valve that passes liquid directly into the Phase I drop tube is installed, the components are isolated from each other with use of an inflatable bladder in order to determine the leak rate of each component. If the leak rate of the drain valve cannot be quantified, the overfill prevention device cannot be tested.

3. BIASES AND INTERFERENCES

3.1 Missing or defective gaskets on the Phase I product adaptor, or a loose adaptor, may bias the results towards noncompliance. Prior to a final determination of

noncompliance_of the component(s), use leak detection solution on all visible components to verify the absence of leaks.

- 3.2 Refueling during the test may bias the results. No vehicle refueling or bulk deliveries to any of the tanks at the facility shall occur during testing.
- 3.3 Product levels less than four (4) inches above the highest opening at the bottom of the submerged drop tube may bias the results toward noncompliance.
- 3.4 Pressure or vacuum in the storage tank headspace may bias the results. Use the Pressure Relief Adaptor in Section 5 to eliminate this potential bias.
- 3.5 Liquid levels in the drop tube that are above the location of the overfill prevention device will bias the results toward compliance.
- 3.6 Leaks in the test equipment will bias the results toward noncompliance. Prior to conducting the test, this bias is eliminated by conducting a leak check of the test equipment. Leak detection solution may also be used during the test to verify the absence of leaks in the test equipment.
- 3.7 Use of this procedure to quantify the leak rate of spill container drain valves that drain liquid into the ullage of the storage tank rather than into the drop tube will yield invalid results.
- 3.8 For remote fill Phase I configurations, the internal diameter of the product pipe assembly is assumed to be four inches in diameter. Product pipe assemblies with a diameter smaller than four inches will shorten pressure up times.
- 3.9 For remote fill Phase I configurations, a measurement of the length of pipe within the entire remote fill product pipe assembly is needed. The product pipe assembly consists of horizontal and vertical segments. The horizontal segment is the length of pipe that connects the remote fill spill container to the direct fill product riser above the underground storage tank (UST), which is sloped a minimum of 1/8 inch per foot toward the UST. The vertical segment is the length of pipe associated with the direct fill product riser, from the top of the product adaptor to the bottom of the UST. A cross sectional view of a typical remote fill product pipe assembly is depicted in Figure 6A. A two-step process is required to correctly measure the entire remote fill product pipe assembly length, as depicted in Figure 6A and described in Section 6 of this test procedure.

4. SENSITIVITY, RANGE, AND PRECISION

- 4.1 Flow Meter. The measurable leak rate is dependent upon the sensitivity, range and precision of the flow meter used for testing. The flow meter minimum sensitivity shall be 12.5 ml/min (0.026 CFH) with a minimum accuracy of ± 5 percent full-scale. The device scale shall be 150 mm (5.91 inches) tall to provide a sufficient number of graduations for readability. For electronic flow metering devices, the minimum sensitivity shall be 1.0 ml/min (0.0021 CFH) with a minimum full-scale accuracy of ± 1.0 percent.

- 4.2 Pressure Gauge.** The measurable pressure is dependent upon the sensitivity, range and precision of the pressure gauge used for testing. For mechanical pressure gauges, the maximum pressure range shall be 0-4 inches H₂O. The minimum full-scale accuracy shall be ±3.0 percent and the gauge shall be readable to the nearest 0.10 inches H₂O. For electronic pressure gauges, the maximum pressure range of the device shall be -10 to 10 inches H₂O. The minimum accuracy shall be ±1.5 percent full-scale range and the pressure gauge shall be readable to the nearest 0.01 inches H₂O.

5. EQUIPMENT

- 5.1 Pressure Gauge.** Use a pressure gauge with minimum specifications listed in Section 4 to monitor the pressure in the drop tube.
- 5.2 Flow Meter.** Use a flow meter with minimum specifications listed in Section 4 to set the required nitrogen flow rate(s).
- 5.3 Nitrogen.** Use commercial grade gaseous nitrogen in a high-pressure cylinder, equipped with a two-stage pressure regulator and a one psig pressure relief valve.
- 5.4 Stopwatch.** Use a stopwatch accurate to within 0.10 seconds to time the pressurization of the drop tube and pressure stabilization period.
- 5.5 Leak Detection Solution.** Any commercial liquid solution designed to detect vapor leaks may be used to verify the pressure integrity of the Phase I product adaptor during this test.
- 5.6 Vapor Adaptor Pressure Relief Assembly.** Use a modified dust cap or a compatible vapor recovery elbow to open the Phase I vapor adaptor during the test. An example of a Vapor Adaptor Pressure Relief Assembly is shown in Figure 1. Screwdrivers or other devices that may damage the vapor adaptor or gasket seal shall not be used to open the Phase I vapor adaptor.
- 5.7 Inflatable Bladder.** Use an inflatable bladder and extension hose, as shown in Figure 2, to isolate the drain valve from the overflow prevention device when applicable. Unless otherwise specified in the certification Executive Order for the system, a "3-4 model" inflatable plumber's bladder may be used.
- 5.8 Product Adaptor Test Cap.** Use a modified product dust cap compatible with the Phase I product adaptor. The cap shall be equipped with connections for a pressure gauge and flow meter. An example of a Product Adaptor Test Cap is shown in Figure 3.
- 5.8.1** For GDF equipped with remote fill configurations, a second product adaptor test cap will be needed to occupy both the direct fill product adaptor and remote fill product adaptor. See Figure 4 and Figure 6A for a typical remote fill Phase I configuration.

5.9 Tank Gauging Stick. Use a tank gauging stick, if required, of sufficient length to verify that the UST liquid level is at least four (4) inches above the highest opening at the bottom of the submerged drop tube. The tank gauging stick shall be equipped with a non-sparking "L" bracket at the end.

5.10 Length Measuring Device. For GDF equipped with remote fill configurations, a measuring device such as a tape measure or measuring wheel can be used to determine the length of the remote fill product pipe assembly. In addition, a tank gauging stick can be used for the vertical segment if the GDF has a restrictor plate and/or a trap door below the adaptor within the direct fill product riser.

6. PRE-TEST PROCEDURES

6.1 The flow meter(s) and pressure gauge shall be calibrated within the 180 days prior to conducting the test. The flow meter(s) shall be calibrated for use with nitrogen. Calibrations shall be conducted in accordance with EPA or CARB protocols. CARB calibration methodology for flow meters and pressure gauges are contained in Appendix D of Air Monitoring Quality Assurance, Volume VI, Standard Operating Procedures for Stationary Source Emission Monitoring and Testing, January 1979.

6.2 Remove the lids of the Phase I spill containers and product adaptor dust caps. Visually determine that the drop tube is equipped with an overfill prevention device.

6.3 Inspect the Phase I product adaptor to ensure that the gasket is installed and that the adaptor is securely attached to the Phase I product riser.

6.4 Verify that the liquid level in the storage tank is at least four (4) inches above the highest opening at the bottom of the submerged drop tube using the tank gauging stick.

6.5 Inspect the drain valve configuration. Verify that the drain valve passes liquid directly into the drop tube, as shown in Figure 2, rather than into the storage tank ullage space.

6.6 If the GDF is equipped with a remote fill configuration (i.e. not a conventional direct fill), measure and record the length of the entire product pipe assembly, including both horizontal and vertical segments as depicted in Figure 6A, on the field data sheet. It is important to note that the horizontal segment of pipe length from the direct fill product riser may not take a direct route to the remote fill spill container. A two-step process is required to correctly measure the entire remote fill product pipe assembly length as follows:

6.6.1 Measure and record the horizontal segment from the remote fill product adaptor to the fixed product adaptor installed on the direct fill product riser. Include an additional 25% to account for slope, underground pipe bends that are not visible on the surface, and the vertical section at the remote fill spill container. There are three ways to determine the horizontal length: direct field measurement at the ground surface, measurement from as-built drawings, or measurement obtained from the local Air Pollution Control District.

6.6.2 Measure and record the vertical segment from the top of the fixed product adaptor installed on the direct fill product riser to the bottom of the UST.

6.6.3 Sum the lengths of the horizontal segment (including the additional 25% mentioned in Section 6.6.1) and vertical segment to obtain the total length of pipe within the remote fill product pipe assembly and record the sum on the field data sheet. An example equation is provided below.

$$TL = (HL \times 1.25) + VL \quad \text{Equation 6-1}$$

Where:

TL = total length of remote fill product pipe assembly (feet)

HL = length of horizontal pipe segment (feet)

VL = length of vertical pipe segment (feet)

6.6.4 Compare the total length of pipe to the values listed in Table 1 (in Section 8) to determine the maximum amount of time to reach 2.0 inches H₂O upon introducing nitrogen.

6.67 Remove the Phase I vapor adaptor dust cap for the tank to be tested. Connect the Vapor Adaptor Pressure Relief Assembly, or equivalent, to the Phase I vapor adaptor. Allow the UST ullage space to reach zero gauge pressure.

7. TEST PROCEDURE (DIRECT FILL CONFIGURATION)

7.1 For GDF's equipped with a remote fill configuration, proceed directly to Section 8.

7.2 Testing options for overfill prevention device and drain valve, if equipped.

7.2.1 If a drain valve is not present, or does not pass liquid directly into the drop tube, proceed directly to Section 7.89.

7.2.2 If a drain valve is present, a tester has either of the following testing options:

7.2.2.1 Proceed directly to Section 7.9 and test the entire drop tube assembly.

Note: If the drop tube assembly leak rate is ≥ 0.15 CFH (71 ml/min) at +2.0 inches H₂O, tester shall conduct testing per Section 7.3.

7.2.2.2 Proceed to Section 7.3.

7.23 Carefully install the inflatable bladder into the drop tube as shown in Figure 2 and inflate.

7.34 Connect the Product Adaptor Test Cap to the Phase I product adaptor and connect the flow meter and pressure gauge to the test cap as shown in Figure 45.

- 7.45** Open the nitrogen supply and adjust the flow to a rate no greater than the maximum allowable leak rate specified for the drain valve only in CP-201 and start the stopwatch for a maximum of 5 minutes.
- 7.5.6** Wait until the pressure gauge indicates a pressure equal to the performance specification pressure for the drain valve as defined in CP-201.
- 7.56.1 If the pressure gauge does not indicate the specified pressure within 5 minutes, the drain valve does not comply with the maximum allowable leak rate specification.
- 7.56.2 If the pressure gauge indicates the specified pressure within 5 minutes, immediately reduce the nitrogen flow in order to stabilize at the specified pressure (± 0.05 inches H₂O) for 30 seconds.
- 7.67** Record the flow rate required to stabilize the pressure specified in CP-201.
- 7.67.1 If the final flow rate is below the detectable limit of the flow meter, record the lowest measurable flow rate and final pressure on the data sheet.
- 7.67.2 If the final flow rate is greater than the capacity of the flow meter, record the highest measurable flow rate and final pressure. No further testing shall be conducted until the leak rate of the drain valve can be determined.
- 7.78** Remove the Product Adaptor Test Cap. Deflate the inflatable bladder and carefully remove it from the drop tube.
- 7.89** Test the entire drop tube assembly, which includes the overfill prevention device and ~~may include the spill container drain valve, if equipped.~~ Connect the Product Adaptor Test Cap to the Phase I product adaptor and connect the flow meter and pressure gauge to the test cap as shown in Figure 45.
- 7.910** Open the nitrogen supply and adjust the nitrogen flow rate to 200 ml/min (0.42 CFH) and start the stopwatch for a maximum of 5 minutes.
- 7.4011** Wait until the pressure gauge indicates a pressure equal to the performance specification pressure for the overfill prevention device as defined in CP-201.
- 7.4011.1 Testing conducted per Section 7.2.2.1 (the option that allows testing the entire drop tube assembly)
- 7.4011.1.1 If the pressure gauge does not indicate the specified pressure within 5 minutes, the overfill prevention device, drain valve, or both does not comply with maximum allowable leak rate specification. Proceed to Section 7.3.
- 7.4011.1.2 If the pressure gauge indicates the specified pressure within 5 minutes immediately reduce the nitrogen flow in order to stabilize

at the specified pressure (± 0.05 inches H₂O) for 30 seconds. Proceed to 7.12.

Note: If the drop tube assembly leak rate is ≥ 0.15 CFH (71 ml/min) at +2.0 inches H₂O, tester shall conduct testing per Section 7.3.

7.11.2 Testing conducted per Section 7.2.2.2 (the option that allows testing the drain valve, followed by the entire drop tube assembly)

7.11.2.1 If the pressure gauge does not indicate the specified pressure within 5 minutes, the overfill prevention device does not comply with the maximum allowable leak rate specification.

7.11.2.2 If the pressure gauge indicates the specified pressure within 5 minutes immediately reduce the nitrogen flow in order to stabilize at the specified pressure (± 0.05 inches H₂O) for 30 seconds. Proceed to 7.12.

7.4412 Record the flow rate required to stabilize at the pressure specified in CP-201.

7.4412.1 If the final flow rate is below the detectable limit of the flow meter, record the lowest measurable flow rate and final pressure on the data sheet.

7.4412.2 If the final flow rate is greater than the capacity of the flow meter, record the highest measurable flow rate and final pressure. No further testing shall be conducted until the leak rate of the drain valve, if equipped, can be determined.

8. TEST PROCEDURE (REMOTE FILL CONFIGURATION)

8.1 Testing options for overfill prevention device and drain valve, if equipped.

8.1.1 If a drain valve is not present, or does not pass liquid directly into the drop tube, proceed directly to Section 8.10.

8.1.2 If a drain valve is present, a tester has either of the following testing options:

8.1.2.1 Proceed directly to Section 8.10 and test the entire remote fill product pipe assembly.

Note: If the product pipe assembly leak rate is ≥ 0.15 CFH (71 ml/min) at +2.0 inches H₂O, tester shall conduct testing per Section 8.2.

8.1.2.2 Proceed to Section 8.2.

8.2 Carefully install the inflatable bladder below the drain valve within the remote fill spill container as shown in Figure 6B and inflate.

- 8.3 Connect the Product Adaptor Test Caps to both the remote fill product adaptor and the direct fill product adaptor. Connect the flow meter and pressure gauge to the test cap installed on the remote fill product adaptor as shown in Figure 5.
- 8.4 Open the nitrogen supply, adjust the nitrogen flow rate to a rate no greater than the maximum allowable leak rate specified for the drain valve in CP-201 and start the stopwatch for a maximum of 5 minutes.
- 8.5 Wait until the pressure gauge indicates a pressure equal to the performance specification pressure for the drain valve as defined in CP-201.
- 8.5.1 If the pressure gauge does not indicate the specified pressure within 5 minutes, the drain valve does not comply with the maximum allowable leak rate specification.
- 8.5.2 If the pressure gauge indicates the specified pressure within 5 minutes, immediately reduce the nitrogen flow in order to stabilize at the specified pressure (± 0.05 inches H₂O) for 30 seconds.
- 8.6 Record the flow rate required to stabilize at the pressure specified in CP-201.
- 8.6.1 If the final flow rate is below the detectable limit of the flow meter, record the lowest measurable flow rate and final pressure on the data sheet.
- 8.6.2 If the final flow rate is greater than the capacity of the flow meter, record the highest measurable flow rate and final pressure. No further testing shall be conducted until the leak rate of the drain valve can be determined.
- 8.7 Remove the Product Adaptor Test Cap from the remote fill spill container. Deflate the inflatable bladder and carefully remove it from the remote fill spill container.
- 8.8 Test the entire remote fill product pipe assembly, which includes the overfill prevention device and the spill container drain valve, if equipped. Connect the Product Adaptor Test Caps to the direct fill product adaptor and remote fill product adaptor. Connect the flow meter and pressure gauge to the test cap at the remote fill product adaptor as shown in Figure 5.
- 8.9 Open the nitrogen supply, adjust the nitrogen flow rate to 200 ml/min (0.42 CFH), and start the stopwatch for the maximum amount of time as specified in Table 1, based on the length of the remote fill product-piping run.
- 8.10 Wait until the pressure gauge indicates a pressure equal to the performance specification pressure for the overfill prevention device as defined in CP-201.
- 8.10.1 Testing conducted per Section 8.1.2.1 (the option that allows testing the entire remote fill product pipe assembly)

8.10.1.1 If the pressure gauge does not indicate the specified pressure within the maximum pressure up time specified in Table 1, the overfill prevention device, drain valve, or both does not comply with the maximum allowable leak rate specification. Proceed to Section 8.2.

8.10.1.2 If the pressure gauge indicates the specified pressure within the maximum pressure up time specified in Table 1, reduce the nitrogen flow in order to stabilize at the specified pressure (± 0.05 inches H₂O) for 30 seconds. Proceed to Section 8.13.

Note: If the remote fill product pipe assembly leak rate is ≥ 0.15 CFH (71 ml/min) at +2.0 inches H₂O, tester shall conduct testing per Section 8.2.

8.10.2 Testing conducted per Section 8.1.2.2 (the option that allows testing the drain valve followed by the entire drop tube assembly)

8.10.2.1 If the pressure gauge does not indicate the specified pressure within the maximum pressure up time specified in Table 1, the overfill prevention device does not comply with the maximum allowable leak rate specification.

8.10.2.2 If the pressure gauge indicates the specified pressure within the maximum pressure up time specified in Table 1, reduce the nitrogen flow in order to stabilize at the specified pressure (± 0.05 inches H₂O) for 30 seconds. Proceed to 8.13.

8.11 Record the flow rate required to stabilize at the pressure specified in CP-201.

8.11.1 If the final flow rate is below the detectable limit of the flow meter, record the lowest measurable flow rate and final pressure on the data sheet.

8.11.2 If the final flow rate is greater than the capacity of the flow meter, record the highest measurable flow rate and final pressure. No further testing shall be conducted until the leak rate of the drain valve, if equipped, can be determined.

Table 1
Time to Pressurize GDF Equipped with Remote Fill Configuration by
Product Pipe Assembly Length

<u>Total Length of Remote Fill</u> <u>Product Pipe Assembly</u> <u>(feet)</u>	<u>Time to Pressurize</u> <u>(minutes)</u>
<u>≤50</u>	<u>5</u>
<u>>50, ≤100</u>	<u>10</u>
<u>>100, ≤150</u>	<u>15</u>
<u>>150, ≤200</u>	<u>20</u>
<u>>200, ≤250</u>	<u>25</u>

89. POST-TEST PROCEDURES

89.1 Carefully remove the Product Adaptor Test Cap and the Vapor Adaptor Pressure Relief Assembly from the Phase I connections.

89.2 Replace the appropriate caps on the Phase I adaptors, and the appropriate lids on the spill containers.

910. CALCULATING RESULTS

910.1 If the flow rate of Nitrogen was at the upper limit of the flow meter and the measured pressure never reached the specified pressure, but was greater than 0.00 inches H₂O, the actual leak rate at a specified pressure shall be calculated as follows:

$$Q_{SP} = (SP)^{1/2} \left[\frac{Q_{actual}}{(P_{actual})^{1/2}} \right] \quad \text{Equation 910-1}$$

Where:

- Q_{SP} = The leak rate of the component at the specified pressure, cubic feet per hour
- Q_{actual} = The actual flow rate of nitrogen, cubic feet per hour
- P_{actual} = The actual measured steady-state pressure at Q_{actual} , inches H₂O
- SP = Specified Pressure, defined in CP-201, inches H₂O

910.2 If both a drain valve and a drop tube overflow prevention device were tested, and if a leak rate could be quantified for both components, the leak rate of the overflow prevention device shall be calculated as follows:

$$Q_{OPD} = Q_{Assembly} - Q_{Drain}$$

Equation 910-2

Where:

- Q_{OPD} = The leak rate of the overfill prevention device, cubic feet per hour
- $Q_{Assembly}$ = The leak rate of the drop tube assembly, cubic feet per hour
- Q_{Drain} = The leak rate of the drain valve, cubic feet per hour

910.3 Commonly used flow rate conversions:

$$1 \text{ CFH} = 471.95 \text{ ml/min}$$

Example: Convert 0.17 CFH to ml/min: $0.17 \text{ CFH} \times 471.95 = 80 \text{ ml/min}$

$$1 \text{ ml/min} = 0.00212 \text{ CFH}$$

Example: Convert 100 ml/min to CFH: $100 \text{ ml/min} \times 0.00212 = 0.21 \text{ CFH}$

Commonly Used Flow Rate Conversions	
0.05 CFH = 24 ml/min	0.21 CFH = 100 ml/min
0.17 CFH = 80 ml/min	0.34 CFH = 160 ml/min

4011. REPORTING RESULTS

Report the results of the quantification of the leak rate through the drain valve and the drop tube overfill prevention device as indicated on Form 1. Districts may require the use of alternate forms, provided they include the same minimum parameters identified on Form 1.

4412. ALTERNATE PROCEDURES

This procedure shall be conducted as specified. Modifications to this test procedure shall not be used to determine compliance unless prior written approval has been obtained from the Executive Officer, pursuant to Section 14 of CP-201 Vapor Recovery Certification Procedure for Gasoline Dispensing Facilities Using Underground Storage Tanks.

Figure 1
Vapor Adaptor Pressure Relief Assembly

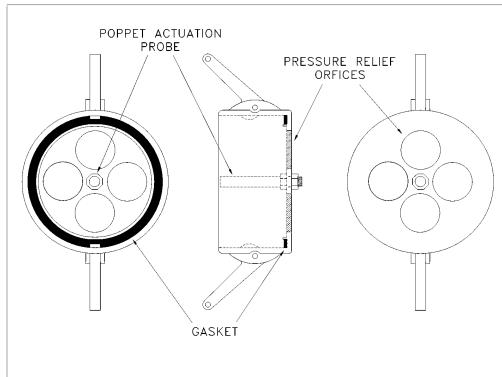
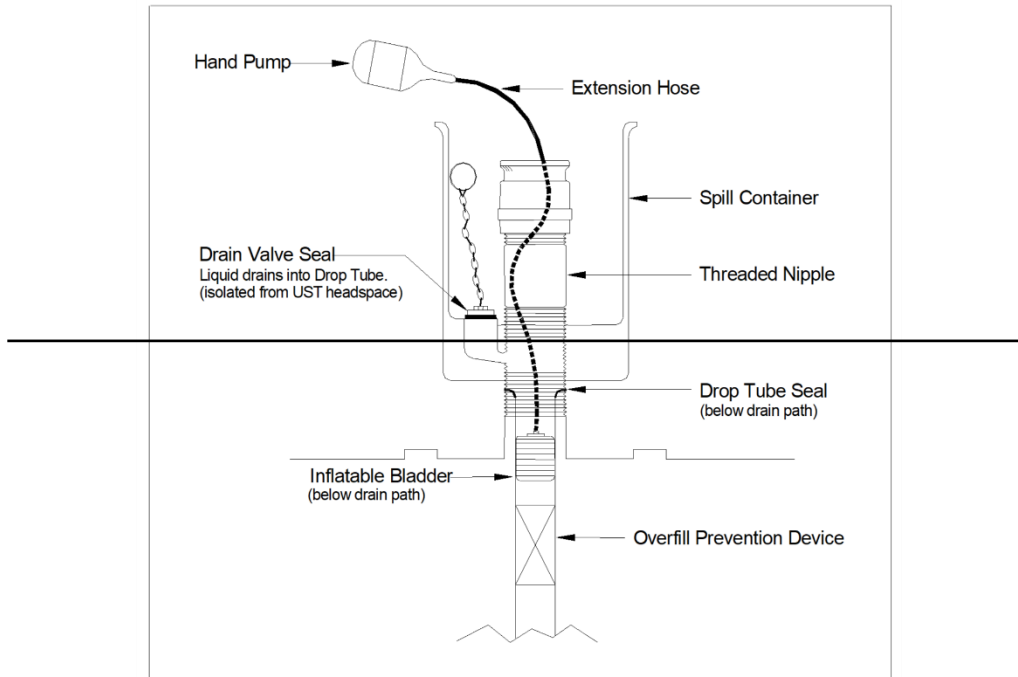

Figure 2
Typical Inflatable Bladder Installation for Direct Fill Configuration



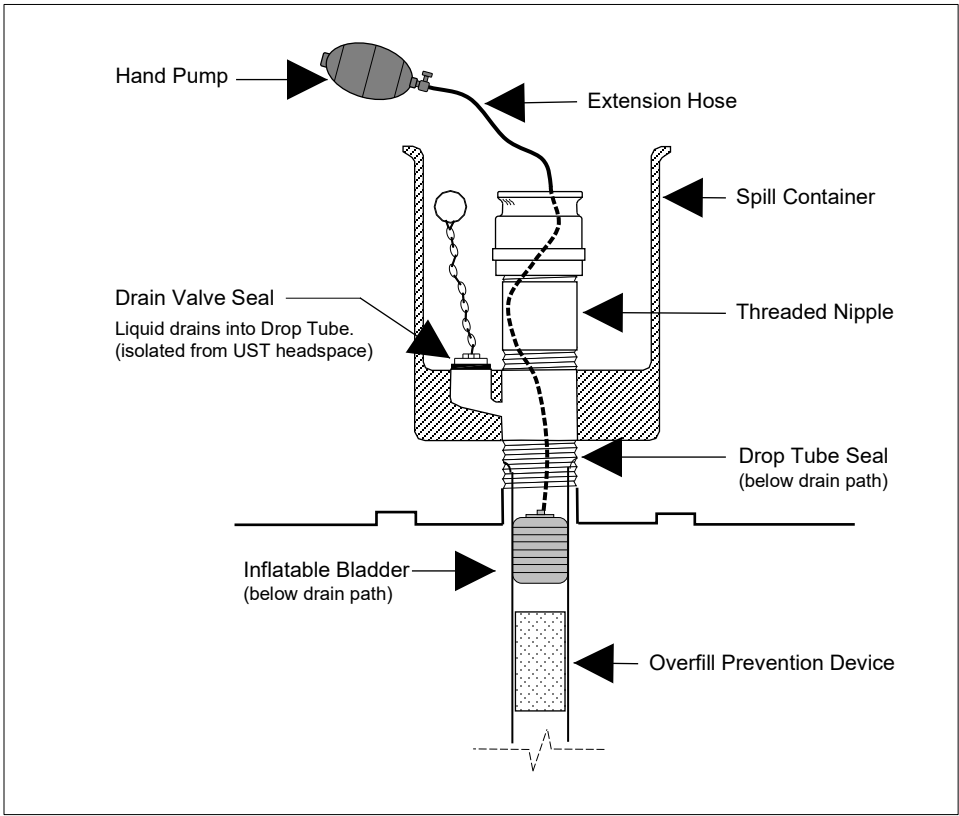

Figure 3
Product Cap Test Assembly

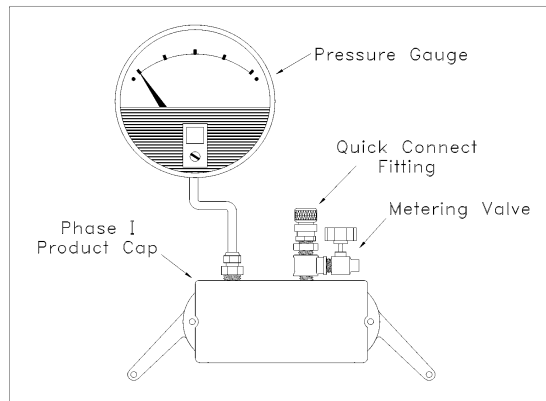

Figure 4
Remote Fill Phase I Configuration

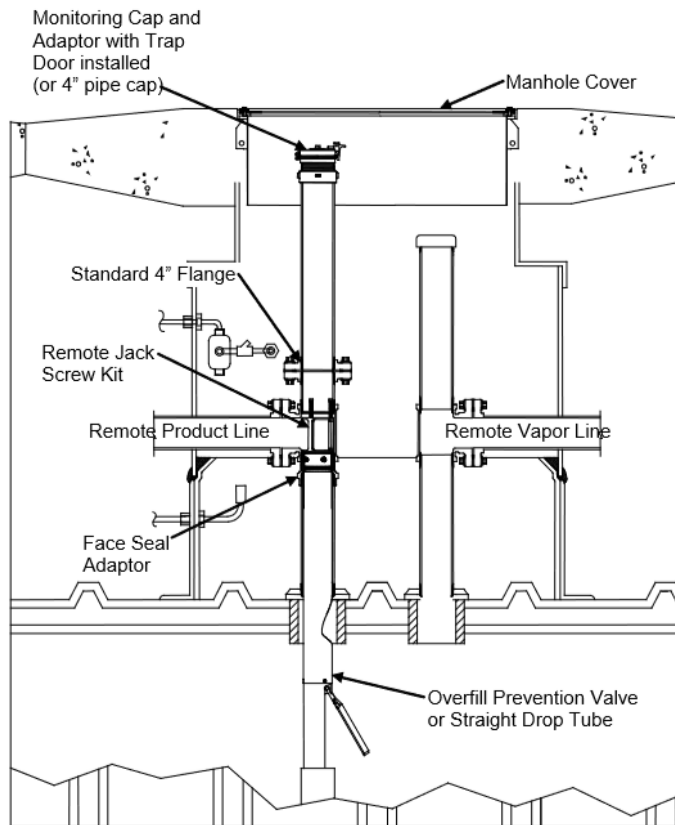

Figure 45
Leak Rate Test Assembly

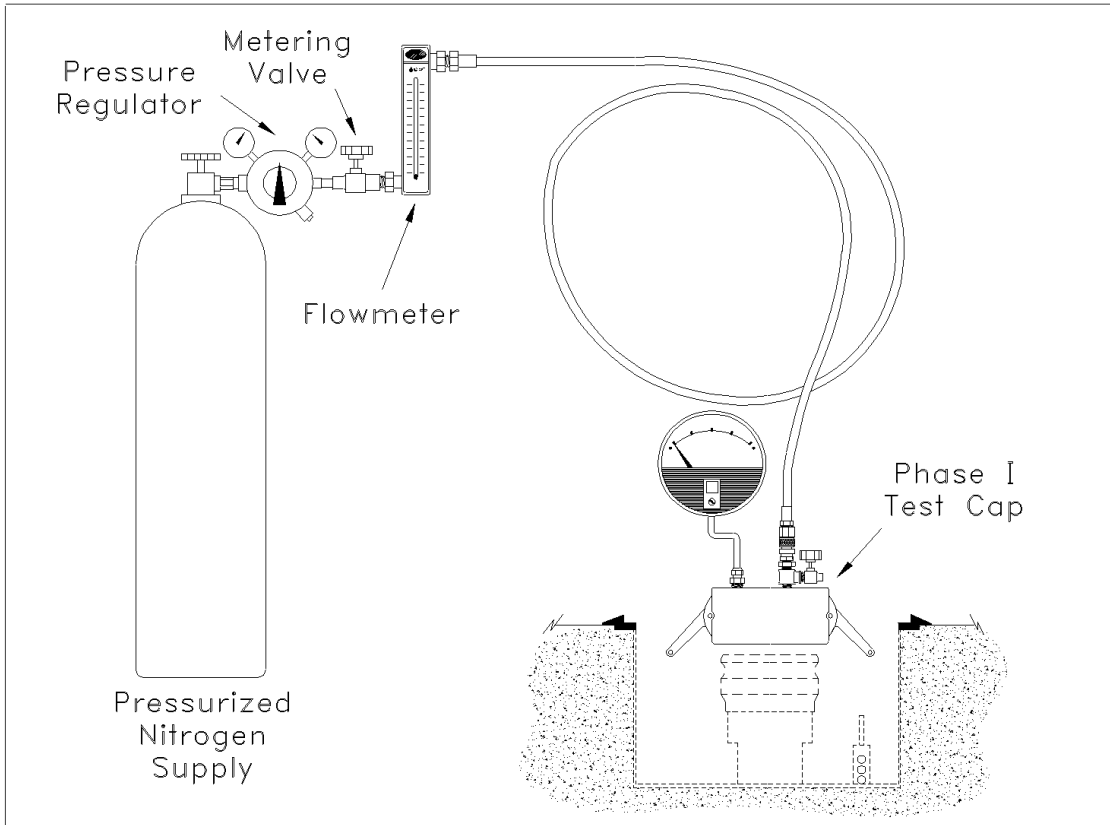

Figure 6A: Remote Fill Product Pipe Assembly Consisting of Two Segments

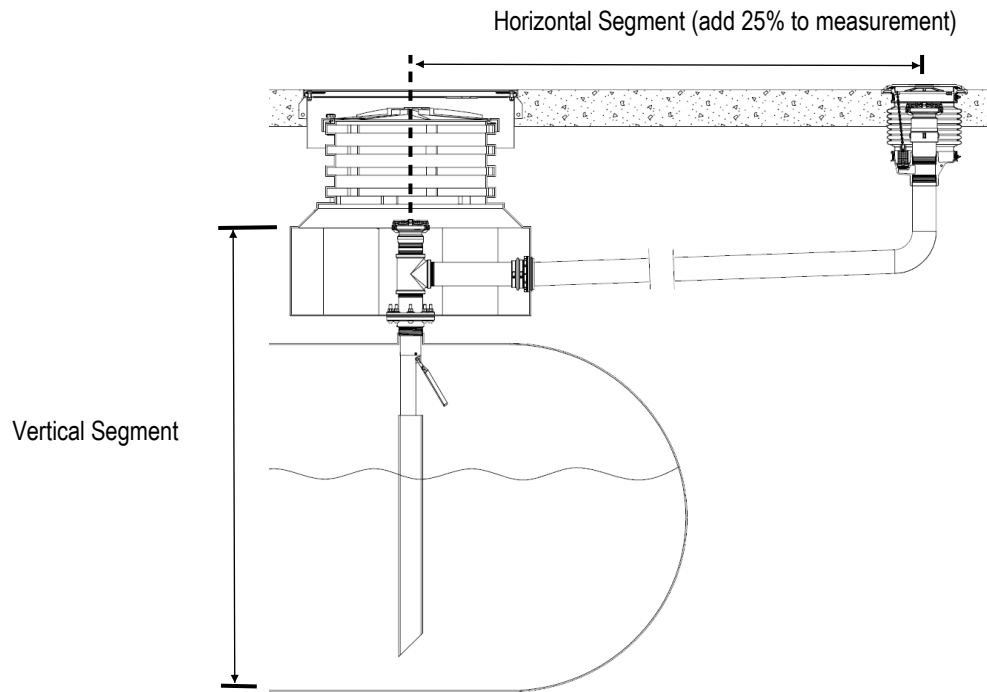
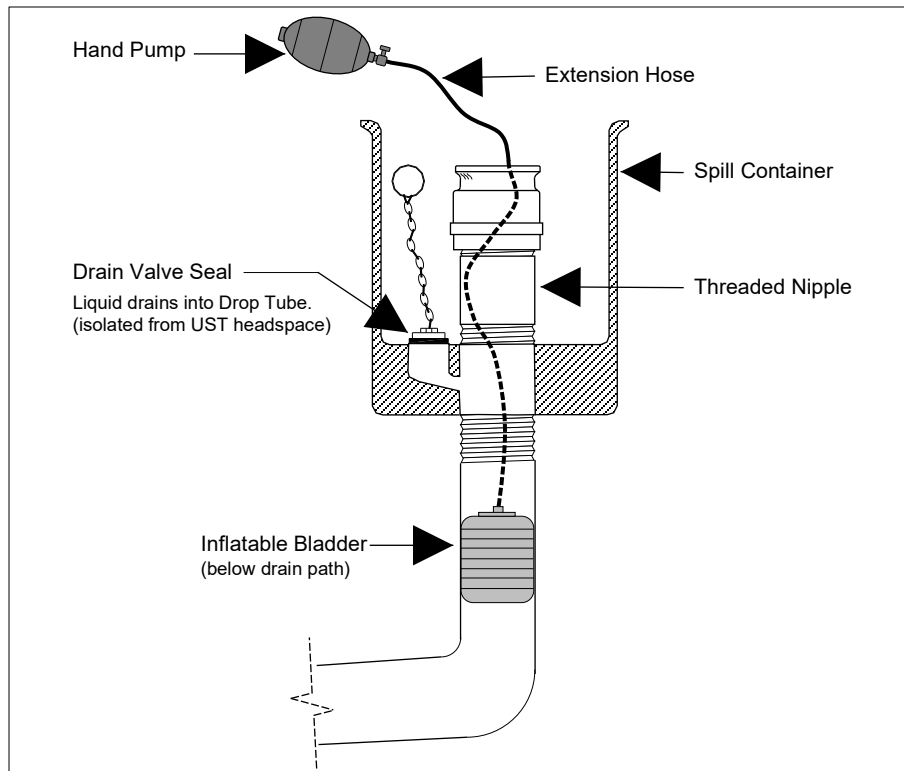

Figure 6B: Typical Inflatable Bladder Installation for Remote Fill Configuration



TP-201.1D Form 1

Drop Tube Overfill Prevention Device and Spill Container Drain Valve Test Procedure

Facility:	Test Company:	Test Date:
Address:	Test Personnel:	
City:	State, Zip Code	
Overfill Prevention Make & Model:	Spill Container Make & Model:	
Date of Last Flow Meter Calibration:	Date of Last Pressure Gauge Calibration:	

Is GDF equipped with Remote Fill Configuration? YES NO

If "YES", record length of remote fill product pipe assembly.

Note: The assembly consists of two measurements as described in Section 6.6 and depicted in Figure 6.

Horizontal Length (HL, feet):	Vertical Length (VL, feet):	Total Length (TL = HL x 1.25 + VL, feet):
-------------------------------	-----------------------------	--

Test Results

Device Type & Product Grade	Time to Pressurize	30-Second Flow Rate (CFH)	30-Second Pressure (in. H ₂ O)	Corrected Flow Rate For Overfill Device Only (See Section 109.2)

Comments:
