

## APPENDIX H

State of California  
AIR RESOURCES BOARD

### PROPOSED

#### SPECIFICATIONS FOR FILL PIPES AND OPENINGS OF 1977 THROUGH 2014 MODEL MOTOR VEHICLE FUEL TANKS

Adopted: March 19, 1976  
Amended: August 5, 1976  
Amended: June 8, 1977  
Amended: December 7, 1990  
Amended: January 22, 1990  
Amended: [[INSERT DATE OF AMENDMENT]]

Note: Proposed amendments to this document are shown in underline to indicate additions and ~~strikeouts~~ to indicate deletions compared to the test procedures as last amended in January 22, 1990.

NOTE: This document is incorporated by reference in section 2235, title 13, California Code of Regulations (CCR). Additional requirements necessary to complete an application for certification of motor vehicles are contained in other documents that are designed to be used in conjunction with this document. These other documents include:

1. "California 2001 through 2014 Model Criteria Pollutant Exhaust Emission Standards and Test Procedures and 2001 through 2016 Model Greenhouse Gas Exhaust Emission Standards and Test Procedures for Passenger Cars, Light-Duty Trucks, and Medium-Duty Vehicles" (incorporated by reference in section 1961(d), title 13, CCR);

2. "California Exhaust Emission Standards and Test Procedures for 2009 and Subsequent Model Zero-Emission Vehicles and Hybrid Electric Vehicles, in the Passenger Car, Light-Duty Truck, and Medium-Duty Vehicle Classes" (incorporated by reference in section 1962.1(h), title 13, CCR);

3. "California Evaporative Emission Standards and Test Procedures For 2001 and Subsequent Model Motor Vehicles" (incorporated by reference in section 1976(c), title 13, CCR);

4. "Malfunction and Diagnostic System Requirements – 1994 and Subsequent Model-Year Passenger Cars, Light-Duty Trucks, and Medium-Duty Vehicles and Engines" (incorporated by reference in section 1968.1, title 13, CCR);

5. "Malfunction and Diagnostic System Requirements – 2004 and Subsequent Model-Year Passenger Cars, Light-Duty Trucks, and Medium-Duty Vehicles and Engines" (incorporated by reference in section 1968.2, title 13, CCR);

6. "California Refueling Emission Standards and Test Procedures for 2001 and Subsequent Model Motor Vehicles" (incorporated by reference in section 1978, title 13, CCR).

## **SPECIFICATIONS FOR FILL PIPES AND OPENINGS OF 1977 THROUGH 2014 MODEL MOTOR VEHICLE FUEL TANKS**

### **I. General**

A. No new 1977 ~~or later~~ through 2014 model year gasoline-powered motor vehicle may be sold, offered for sale, or registered in California unless such vehicle complies with the following specifications for fill pipes and openings of motor vehicles fuel tanks. In addition, these specifications shall apply to each new 1993 ~~and subsequent~~ through 2014 model methanol-fueled passenger car, light-duty truck, medium-duty vehicle, and heavy-duty vehicle. Any references made in these specifications to gasoline or gasoline-fueled vehicles shall be applicable also to methanol or methanol-fueled vehicles. The Executive Officer may exempt vehicles for which compliance with the specifications is found to be technologically infeasible, in accordance with Paragraph 9.

B. Evidence to show compliance with these specifications shall be submitted to the Executive Officer of the Air Resources Board with the application of certification of new vehicles required by Chapter 3, Subchapter 1, Article 2, of Title 13 of the California Code of Regulations.

C. Sections 4 through 8 shall apply to new 1984 ~~and later~~ through 2014 model year otto-cycle motor vehicles, except motorcycles.

### **II. Definitions**

A. "Fill pipe face" means the surface of the open end of the fill pipe that seals against the fuel tank cap when the cap is in place.

B. "Test nozzle spout" means a rod with dimensions shown in Figure 4 (bottom left corner), used to establish the reference lines around which the fill pipe access zone is defined.

C. "Fill pipe access zone" means the spatial zone in the vicinity of the fill pipe, as described by Figures 3 and 4, which is used for nozzle insertion, and which must be free of obstructions.

D. "Reference plane" means the plane, chosen by the vehicle manufacturer, in which the vapor recovery nozzle should remain during vapor recovery nozzle insertion, and which contains the axial centerline of the fill pipe face.

E. "Normal resting position of the test nozzle spout" means the position of the test nozzle spout is in when all of the following conditions are met:

1. the test nozzle spout is inserted into the fill pipe such that the axial centerline of the test nozzle spout lies in the reference plane;
2. the locking ring of the test nozzle spout is located immediately on the inside (i.e., the vehicle tank side) of the locking lip;
3. either the locking ring of the test nozzle spout rests upon the fill pipe wall, or the test nozzle pout shaft rests upon the locking lip as shown in Figures 1 and 2 respectively; and
4. the fuel dispensing end of the test nozzle spout (which is indicated in Figures 1 and 2) is in contact with a restraining point.

The normal resting position of the test nozzle spout is illustrated in Figures 1 and 2.

F. "Unlatched position of the test nozzle spout" means the position of the test nozzle spout is in when all of the following conditions are met:

1. the test nozzle spout is inserted into the fill pipe with the axial centerline of the test nozzle spout contained in the reference plane;
2. the locking ring of the test nozzle spout is resting on the upper surface of the locking lip so as to raise the nozzle handle through the minimum angle required (from the normal resting position) to effect insertion of the test nozzle spout into the fill pipe; and
3. the fuel dispensing end of the test nozzle spout (which is indicated in Figures 1 and 2) is in contact with a restraining point.

The unlatched position of the test nozzle spout is illustrated in Figures 1a and 2a.

G. "Angle Alpha" means the angle between the axial centerline of the test nozzle spout when in its normal resting position, and the axial centerline of the fill pipe face. Alpha is considered a positive angle when the fuel dispensing end of the test nozzle spout (which is indicated in Figures 1 and 2) is pointing down relative to the axial centerline of the fill pipe face, as illustrated in Figures 1 and 2.

H. "Angle Beta" means the angle between the axial centerline of the test nozzle spout when in its unlatched position, and the axial centerline of the fill pipe face. Beta is considered a positive angle when the fuel dispensing end of the test nozzle spout (which is indicated in Figures 1a and 2a) is pointing down relative to the axial centerline of the fill pipe face, as illustrated in Figures 1a and 2a.

I. "Restriction device" means a fill pipe device installed by the vehicle manufacturer to prevent insertion by a leaded nozzle spout and to prevent fueling with

leaded gasoline, pursuant to regulations of the United States Environmental Protection Agency.

J. "Vapor recovery nozzle", for the purpose of these specifications, means a nozzle, unleaded or leaded as appropriate for fueling vehicles, certified by the state board, pursuant to the board's "Certification procedures for Gasoline Vapor Recovery Systems at Service Stations" established in Section 94001 of Title 17, California Code of Regulations, at any time between January 1, 1981 and September 14, 1982, together with an appropriate vapor hose. An alternative vapor recovery nozzle means any nozzle certified subsequent to September 14, 1982.

K. "Premature nozzle shut-off" means any automatic shut-off of the vapor recovery nozzle before the vehicle fuel tank is filled to either 90 percent of the nominal fuel tank capacity or to within two gallons less than the nominal tank capacity, whichever corresponds to the smaller quantity of gasoline in the fuel tank.

L. "Liquid gasoline loss" means any liquid gasoline that leaves the fill pipe/nozzle interface during dispersing or after nozzle shut-off and includes any liquid gasoline on the ground, on the vehicle, or that enters the nozzle bellows, nozzle body vapor passage, or vapor hose, but does not include liquid gasoline in the nozzle spout.

### **III. General Design Specifications**

A. The fill pipe face shall have a smooth surface which is flat within 0.025 centimeter TIR (total indicated reading) against which any vapor recovery nozzle as defined in Section 2.J can effect a vapor-tight seal. The fill pipe face shall be round in cross-section, and shall have an outside diameter of less than 5.75 centimeters.

An internal locking lip shall be provided around at least 100 degrees of the inside circumference of the fill pipe, with at least 35 degrees extending to either side of the reference plane.

The height of the lip, as measured from the inside wall of the fill pipe, shall not be less than 0.25 centimeters, or shall not be less than 0.85 centimeters as measured from the outside wall of the fill pipe if the outside diameter of the fill pipe is between 5.2 and 5.75 centimeters. The depth of the lip shall not be less than 0.4, nor more than 1.3 centimeters into the fill pipe as measured in the reference plane from the fill pipe face. If any portion of the locking lip has depth less than 0.4 centimeters, the depth transition shall not be greater than 0.006 centimeters per degree of arc throughout that portion of the locking lip.

B. The fill pipe and all surrounding bumpers, body parts, and factory installed accessories shall be designed and fabricated so that the fill pipe access zone as delineated by Figure 4 is not obstructed. Allowance must be made for production tolerances, as these are not included in this access zone. The access zone shall allow

for insertion of any vapor recovery nozzle as defined in section 2.J in at least one orientation within  $\pm 90$  degrees of the upright or vertical position.

The fill pipe access zone shall be determined by first locating reference lines A and B, and Point D, E, and P. Point P, as shown in Figures 3 and 4, is located by finding the intersection point of 30.6 centimeters radius arcs struck from points D and E. Point P shall be the point from which the 19, 24, and 30.6 centimeter radii of the handle access zone (as indicated in Figures 3 and 4) as constructed. The fill pipe access zone is defined relative to reference lines A and B, as shown in Figures 3 and 4. Reference line A is the axial centerline of the test nozzle spout when it is in its normal resting position. Reference line B is the axial centerline of the test nozzle spout when it is in its unlatched position.

The sealing zone as shown in Figure 4 shall be retained normal to the axial centerline of the fill pipe face. In between the handle access zone and the sealing zone, a smooth blend shall be provided as shown in Figure 4.

C. The internal portions of the fill pipe shall be configured such that test nozzle spout can be inserted far enough into the fill pipe to allow entrance of its locking ring beyond the fill pipe locking lip, and to allow deflection of the spout to the normal resting position and back to the unlatched position without binding. If the fill pipe contains a restriction device or other valve, it must be positioned so that the test nozzle spout in the normal resting position penetrates the restriction device or other valve by a minimum of 2.25 centimeters and allows free delivery of gasoline to the vehicle tank. The internal portions of the fill pipe shall also be configured to hold the test spout in its normal resting position such that the angle Alpha ( $\alpha$ ) falls within the range  $20 \text{ degrees} \geq \alpha \geq -10 \text{ degrees}$  as shown in Figures 1 and 2.

D. The fill pipe shall be oriented such that the axial centerline of the test nozzle spout in the normal resting position forms an angle of not less than 15 degrees with the horizontal plane, with the fuel dispensing end (which is indicated in Figures 1 and 2) pointing down. For 1980 and later model year vehicles, this angle shall not be less than 30 degrees.

#### **IV. Fill Rate Specifications**

A. Except as provided in Section 4.B below, the fill pipe shall accept a fill rate of 8 gallons per minute using the test procedures described in Section 6.

B. The fill pipe on 1987 and subsequent model year vehicles, except for those vehicles with fuel system designs carried over from the 1986 model year without change, shall accept a fill rate of 10 gallons per minute using the test procedure described in Section 6.

C. There shall be no premature nozzle shut-off in 90 percent of the test repetitions for any test nozzle using the test procedures described in Section 6.

## **V. Spillage and Spitback Specifications**

A. There shall be no more than 1 millimeter of liquid gasoline loss per test in 90 percent of the tests using the test procedures described in Section 6.

B. There shall be no unlatching of the vapor recovery nozzle during dispensing or upon nozzle shut-off using the test procedure described in Section 6.

## **VI. Test Procedures**

The following test procedures and test conditions shall be used for determining compliance with the specifications in Section 4 and 5.

A. Each different fill pipe/tank configuration, as appropriate to represent adequately the manufacturer's product line, shall be tested with two vapor recovery nozzles. Each nozzle must be from a different manufacturer. At least one of the two nozzles shall be a balance-type. Each nozzle shall include a hold-open clip for hands-off dispensing. Upon the request of a vehicle manufacturer, the Executive Officer or his designate may approve alternate vapor recovery nozzles and hoses for use with the test procedures.

B. The fill pipe shall be tested as installed in the vehicle. Fuel system mock-ups sufficiently complete to demonstrate production vehicle compliance with these specifications may be used.

C. The vehicle shall be parked in a level attitude and oriented such that normal vapor and liquid hose loads are applied to the nozzle. Normal vapor and liquid hose loads may be represented by applying a retractor cable tension of approximately ten pounds to a hose clamp attached to the liquid hose approximately three feet from the nozzle as measured along the hose.

D. Gasoline used as fuel during the tests shall have a Reid vapor pressure of at least 8.5 pounds per square inch (psi) and be at a temperature of 21° plus or minus 5° Centigrade.

E. The pressure drop from the nozzle/fill pipe interface through the vapor passage shall be nominally 0.5 inch of water (gauge) as measured with a nitrogen gas flow of 60 cubic feet per hour through the vapor passage.

F. Each test shall be conducted as follows:

At the start of the test the fuel tank shall be approximately 10 percent of the nominal tank capacity. The nozzle to be used for dispensing gasoline shall be in the normal hands-off-latched position. The fill rate shall be the minimum rate necessary to demonstrate compliance with the applicable fill rate specification set forth in Section 4. The nozzle shall be allowed to dispense gasoline until automatic nozzle shut-off.

If a premature nozzle shut-off occurs, the nozzle shall be left in the fill pipe in the same position. Dispensing shall be resumed within 10 seconds at the fill rate specified in Section 4 and dispensing shall continue until the fuel tank is filled to within 90 percent of the nominal fuel tank capacity or to within two gallons of the nominal fuel tank capacity, whichever corresponds to the smaller quantity of gasoline in the vehicle fuel tank.

G. A minimum of five tests with each chosen nozzle shall be completed to demonstrate compliance with the fill rate and spillage/spitback specifications. If there is any premature nozzle shut-off or instance of liquid gasoline loss greater than 1 millimeter during the first five test with any chosen nozzle, a minimum of ten tests with that nozzle shall be completed to demonstrate compliance with the fill rate and spillage/spitback specifications.

H. At the request of a manufacturer, the Executive Officer may approve the use of an alternative test procedure by the manufacturer upon a determination that the alternative test procedure is equivalent to the adopted test procedure. The manufacturer shall be responsible for demonstrating the equivalency of the alternative test procedure.

I. For fill pipe/tank configurations with fuel system designs unchanged from a prior model year, and which have been tested using the adopted test procedure or by an equivalent test procedure acceptable to the Executive Officer as specified in Section 6.H, the test results from the prior model year may be used for determining compliance to these specifications.

## **VII. Specifications to Reduce Damage to Vapor Recovery Nozzles**

To avoid damage to the bellows and faceplates of vapor recovery nozzles, there shall be no sharp projections or edges within the fill pipe access zone, along the surface of the fill pipe access zone, or along the surface of adjacent zones outside of the fill pipe access zone, which could foreseeably damage the bellows or faceplate of nozzles during nozzle insertion, latching, dispensing or removal. Fill pipe access doors, including license plate holders and license plates when used as access doors, and all associated door and license plate mounting brackets, screws, and other hardware shall stand free of the fill pipe access zone during nozzle insertion, latching, dispensing, and removal. This Section shall also apply to all factory installed accessories in the vicinity of the fill pipe and opening.



## **VIII. Fill Pipe Assembly and Restriction Device Durability and Other Specifications**

A. The manufacturer of each motor vehicle shall warrant to the ultimate purchaser and each subsequent purchaser that the vehicle is: (1) designed, built, and equipped so as to conform, at the time of sale, with the specifications in Sections 4, 5, 7, 8.B, and 8.C herein, and (2) free from defects in materials and workmanship which cause the fill pipe assembly, including restriction device, to fail to conform to the specifications in Sections 4, 5, 7, 8.B, and 8.C herein for the useful life of the vehicle as defined in Section 2035 of Title 13, California Code of Regulations. The provision of Sections 2037 (d) – (k), 2038, 2039, 2040, and 2041 of Title 13, California Code of Regulations, shall be applicable to the warranty. The fill pipe assembly, including restriction device, shall be subject to vehicle emissions related defects report and vehicle or engine recall procedures in Title 13, Chapter 3, Subchapter 2, Article 2, California Code of Regulations.

B. Any restriction device in a motor vehicle shall be sufficiently durable to withstand simple tampering and to prevent expansion of the restriction device diameter to 2.4 centimeters or removal of the restriction device without extraordinary effort.

C. The fill pipe assembly including fuel tank cap shall not expel liquid gasoline during normal driving maneuvers or parking attitudes for which the vehicle is designed irrespective of ambient temperature or tank level up to nominal capacity.

D. The fill pipe assembly of all methanol-fueled vehicles shall be designed to resist the insertion of flexible tubing of a diameter that is feasible for use in siphoning fuel. Manufacturers of methanol-fueled heavy-duty vehicles in excess of 14,000 pounds gross vehicle weight may request an exemption from this requirement. The request shall be submitted to the Executive Officer and shall be granted if the manufacturer demonstrates that compliance with this requirement is technically infeasible.

## **IX. Exemption of Vehicles**

A. A manufacturer may apply for an exemption from the fill pipe and fuel tank opening specifications in paragraphs 3 through 8 for any of its vehicles by applying in writing to the Executive Officer. Application should be submitted at least 60 days prior to the manufacturer's date for final design commitment. The application shall set forth:

1. the specific models for which the exemption is sought;
2. for each such model all facts which demonstrate that compliance with the specifications is technologically infeasible; and
3. evidence showing what efforts have been and will be made by the manufacturer to overcome technological infeasibility, and what the state-of-art technology and problems consist of.

B. Upon receipt of an exemption application, together with sufficient supporting evidence, the Executive Officer may make a finding of technological infeasibility and grant an exemption. The exemption may be limited to specific models, specified body styles of any vehicle model, and/or specified model years. In determining whether to grant an exemption, the Executive Officer shall consider technologies available to the motor vehicle industry as a whole. The Executive Officer may condition an exemption upon a commitment by the manufacturer to develop new technologies in accordance with a responsible compliance schedule approved by the Executive Officer. No exemption shall be granted unless the manufacturer has demonstrated a good faith effort to overcome technological infeasibility.

C. The manufacturer shall bear the responsibility for submitting evidence to the Executive Officer sufficient to justify the granting of an exemption.

Figure 1.

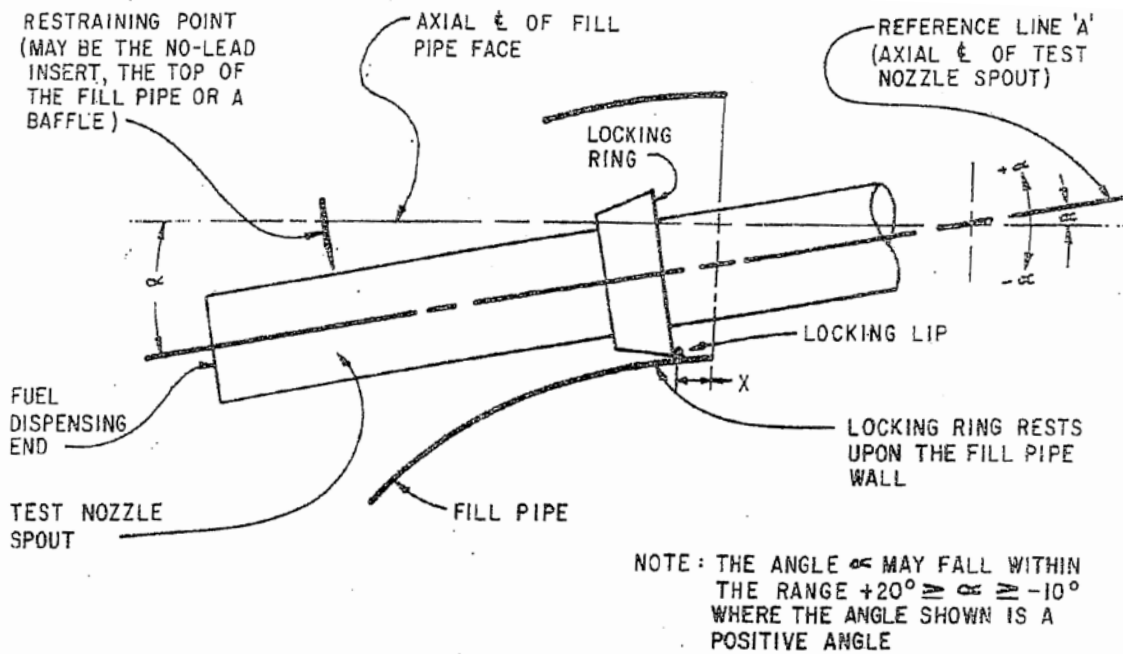

FIGURE 1 : SAE J1114 TYPE FILL PIPE (NORMAL RESTING POSITION)

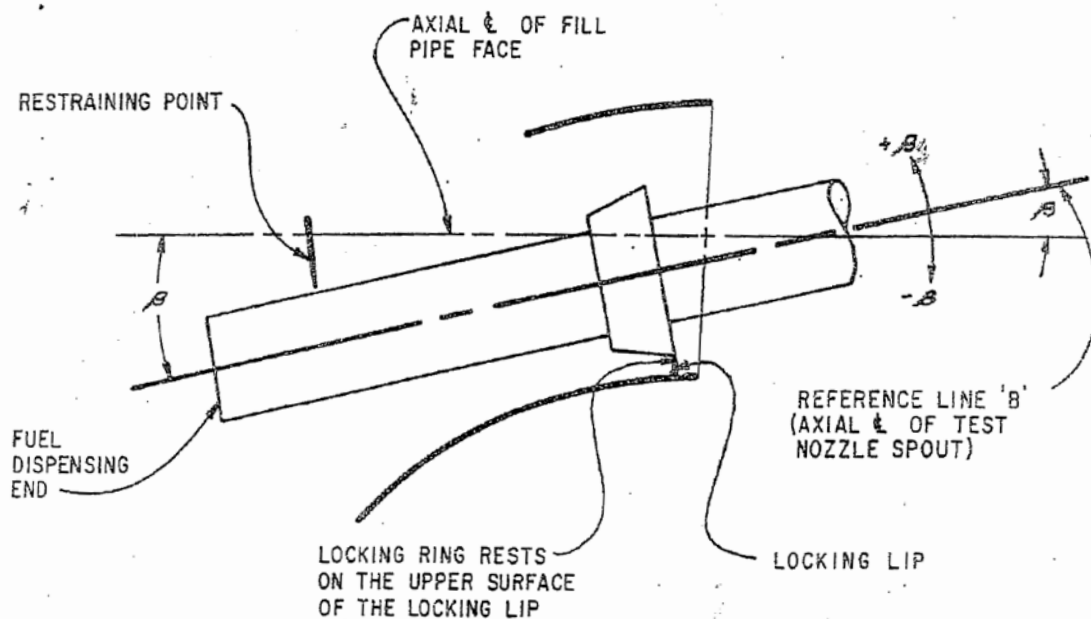

FIGURE 1a : SAE J1114 TYPE FILL PIPE (UNLATCHED POSITION)

Figure 2.

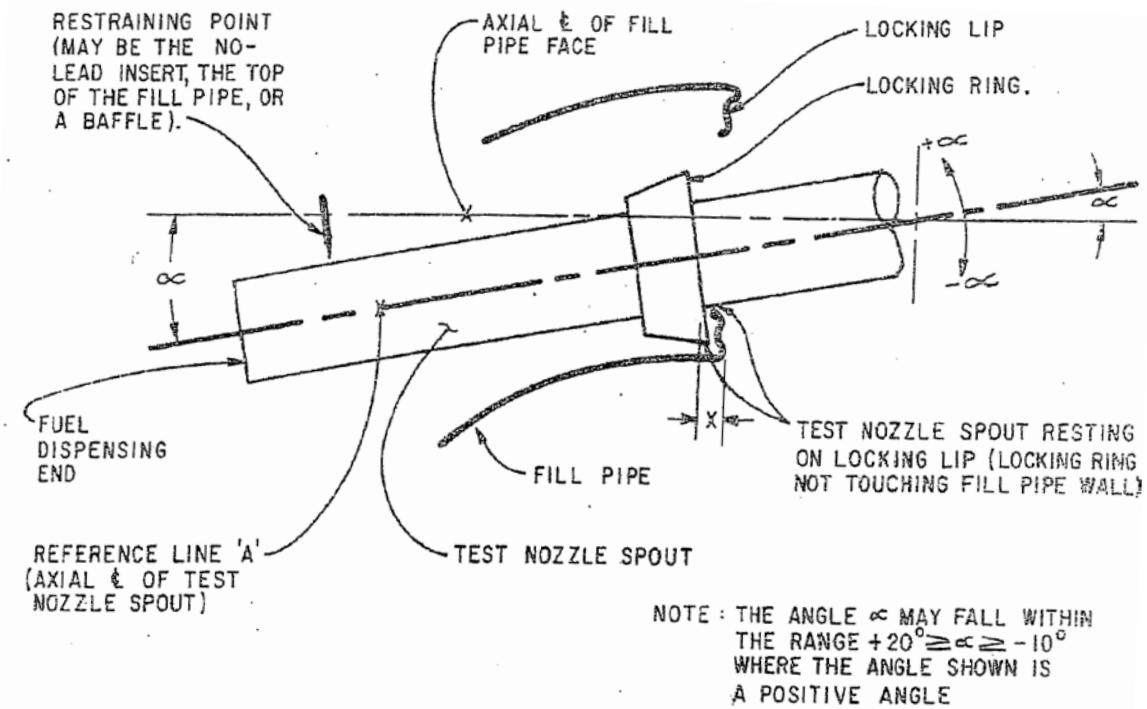

FIGURE 2 : SAE J829B TYPE FILL PIPE (NORMAL RESTING POSITION)

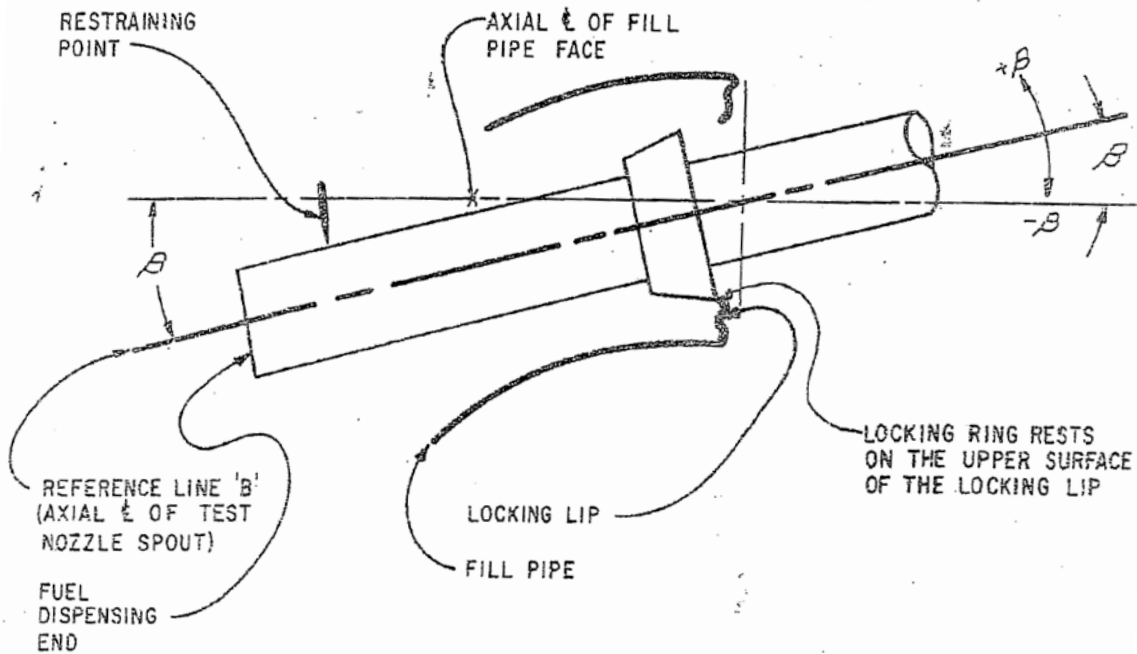

FIGURE 2a : SAE J829B TYPE FILL PIPE (UNLATCHED POSITION)

Figure 3.

