



Drive Forward Truck Forum: Infrastructure Workgroup

Exploring the Potential of Fuel Cell Refuse and Recycling
Trucks Running on Renewable Hydrogen

March 9, 2026

California Continues Forward

Executive Order N-27-25

- Reaffirms California's commitment to deploy ZEVs and improve air quality

ZEV Forward

- Assessed additional actions needed to advance ZEV adoption

Report to Governor

- Recommended actions to further light-, medium-, and heavy-duty ZEV adoption in the state

Drive Forward

Drive Forward

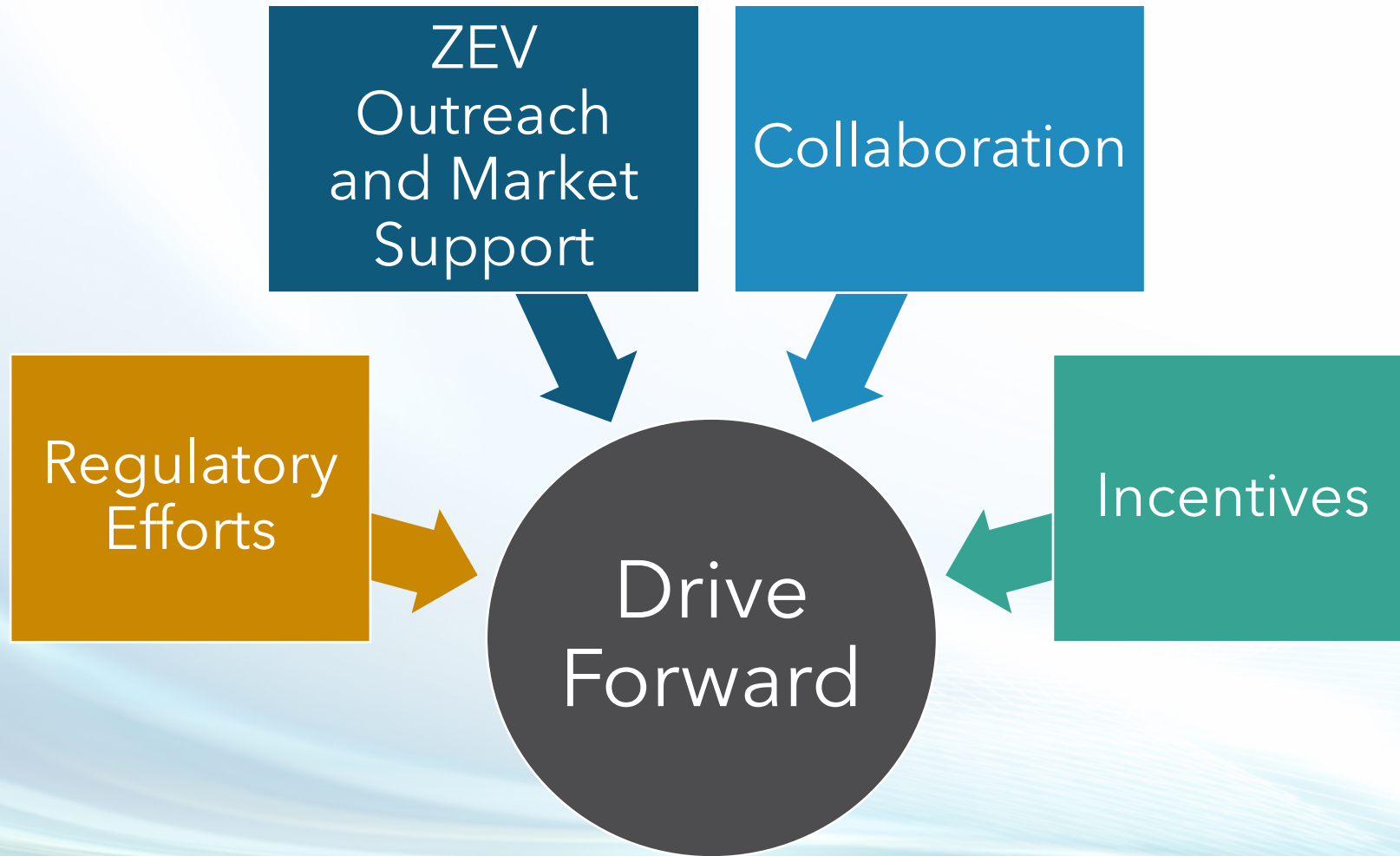

Drive Forward and ZE Infrastructure Websites

- Drive Forward website activities, engagement opportunities and workshops
 - <https://ww2.arb.ca.gov/drive-forward>
 - Request a meeting:
DriveForward@arb.ca.gov
- Drive Forward Truck Forum: Infrastructure Workgroup
 - New webpage: <https://ww2.arb.ca.gov/drive-forward-truck-forum-infrastructure-workgroup>
 - Shortlink: <https://ww2.arb.ca.gov/ZEinfrastructure>
 - Contact: ZEinfrastructure@arb.ca.gov



2026 Drive Forward Truck Forum: Infrastructure Workgroup Panel

Co-Chairs:

Lisa McGhee, Tom's Truck Center
Bradley Northup, City of Carlsbad
Leslie Goodbody, CARB

Panelists:

Angela Clapp, Port of Oakland
Aravind Kailas, Volvo Group NA
Chris Shimoda, Consultant to CTA
Chuck Loy, Sysco Corporation
Clair Keleher, Bay Area AQMD
Collin MacGregor, Range Energy
Cristina Marquez, IBEW Local 596
Damon Wyckoff, Calaveras County
Water District

Panelists:

Dirk Piersma, Gemperle Farms
Emmanuel Carrillo, Talon Logistics, Inc.
Erick Karlen, Pacific Gas & Electric
Eugene Litvinov, Hyundai Motor NA
Glen Kedzie, Truck Renting & Leasing
Association
Glenn Choe, Toyota Motor NA
Isaac Ritter, J.B. Hunt Transport Services
Jamie Hall, EV Realty
Jason Berry, Terawatt Infrastructure
Jessie Denver, GoBiz
Jimmy Andreoli II, Baker Commodities

Panelists:

Kate Reid, California Energy Commission
Lindsay Shigetomi, Environmental Defense
Fund
Mark Koppang, Raley's
Ole Hoefelmann, First Element Fuel
Priscilla Quiroz, CA Municipal Utilities
Assoc.
Richard Battersby, City of Oakland
Ruth Alfson, Matrix Consulting Group
Sam Wilson, Union of Concerned Scientists
Scott Moon, Los Angeles Department of
Water and Power
Steven Fenaroli, California Farm Bureau

Agenda

- Introduction
- South Coast AQMD Fuel Cell Refuse Truck Demonstration, Symbio
- Integrating Zero-Emission Trucks into Waste Collection, Recology
- Producing Renewable Hydrogen from Green Waste, Raven SR
- Landfill Gas to Hydrogen, Utility Global
- Q&A and Focused Discussion
- Next Steps

California Solid Waste Collection Vehicles (SWCV) by Age and Fuel Type

Model Year	Years Operating	Diesel	Natural Gas	Battery Electric	Fuel Cell	Total by Model Year
2000-2010*	16-25	2,250	801	0	0	3,051
2011-2020	6-15	1,484	5,659	3	0	7,146
2021-2027	0-5	910	1,829	125	1	2,865
Total by fuel type		4,644	8,289	128	1	13,062

Source: CARB, EMFAC2025, May 2025, <https://arb.ca.gov/emfac/>, accessed February 2026

* Likely an overestimate. Dept. of Motor Vehicles does not require annual registration renewal for publicly owned vehicles.

Total SWCVs by Region



Note: Gray counties have ≤ 20 SWCVs
Source: CARB, EMFAC2025, May 2025,
<https://arb.ca.gov/emfac/>, accessed Jan. 2026

SWCV Distribution by Alt Fuel Type

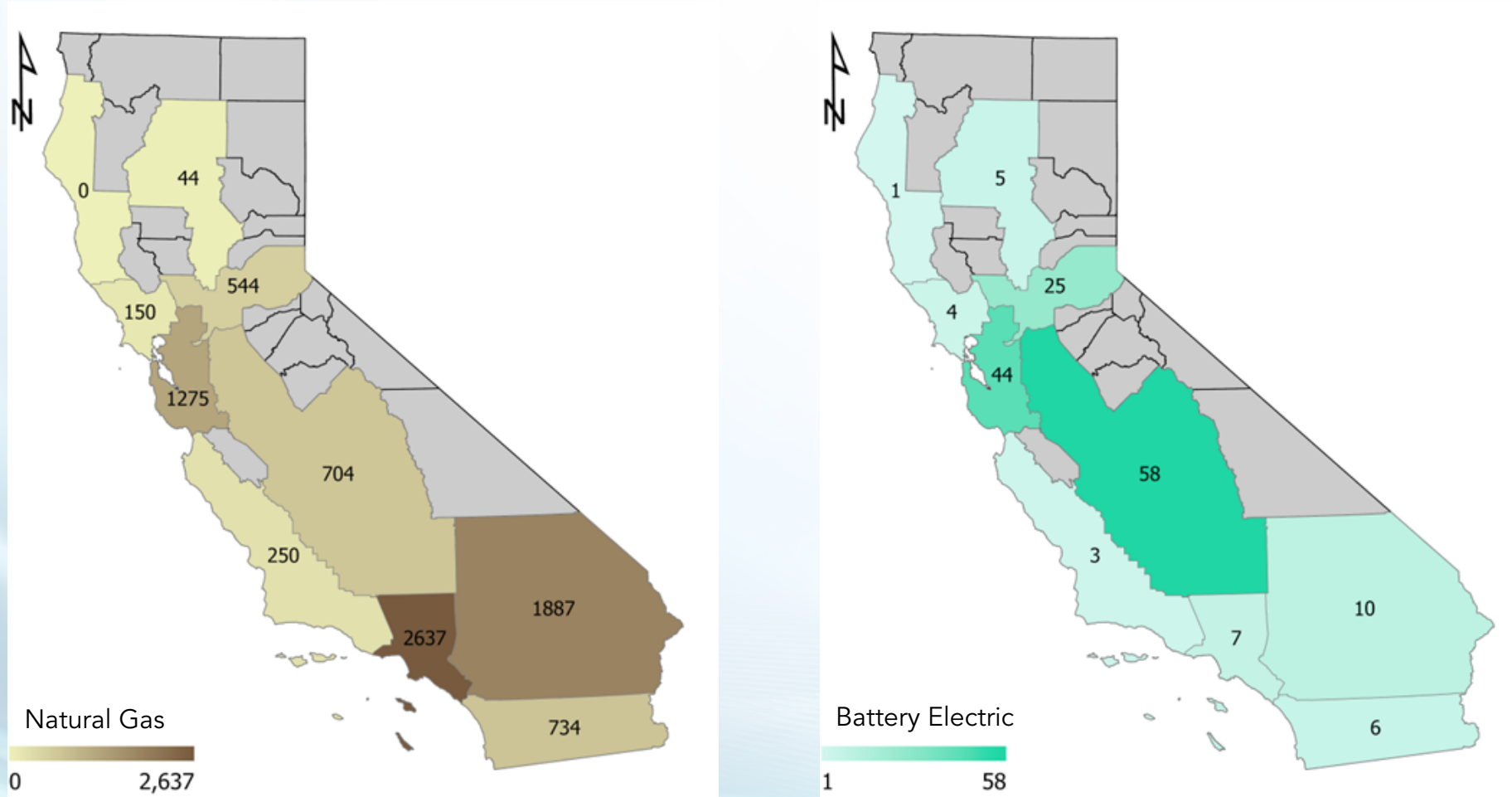



Symbio North America Presentation

*March 9, 2026
Juan Anders Garza*

<https://www.symbio.one/en/symbio-north-america>

Symbio North America Timeline



Engages
in Fuel Cell



NA Operation Start
POWAY



First Project
Demo 1 FCEV



CEC - Grant
Exp. Mfg. Capability



Operation Start
TEMECULA



Re-Defining
Strategy



Ramp up

2000

2010

2019

2021

2022

2023

2024

2025

2026



SYMBIO

Creation



SYMBIO
A FAURECIA MICHELIN HYDROGEN COMPANY

Forvia & Michelin
Equal shareholders

INNOPLATE

A Schaeffler Symbio Hydrogen Company

A 50/50 JV
BPPs



SYMBIO
A FRONT-RUNNER HYDROGEN COMPANY

Stellantis
Joins partnership



SymphonHy
Inauguration



Production
Readiness

**2025 – FCEV Modular
Architecture development**

**Over + 8M km.
on-road experience**



Symbio FCEV Architecture

FC Power Ratings

- 75 kW
- 150 kW
- 225 kW
- 300 kW



HV Battery

- 105 kWh
- 150 kWh
- 210 kWh
- 282 kWh



HV Distribution

- Multiple Fuel Cell and battery configurations

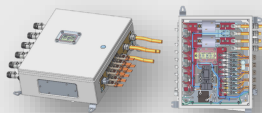

LV Distribution

- Smart, multiple configurations



Controller

- Single controller multiple configurations

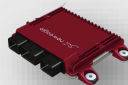

eDrive

- Single Drive
- eAxle



eAccessories

- Steering Pump
- Air Compressor
 - DC/DC
- AC Compressor
- PTC Heater
- HV Cooling Fans
- LV Cooling Fans



Hydrogen Storage System

- 350 – 700 bar
- Back of Cab
- Side Tank
- Back + Side



Key Notes

- Modular Architecture
- Maximizes “off shelf” components
- Reduces weight and improves flexibility

Flexible, Industry Friendly MD/HD Solutions

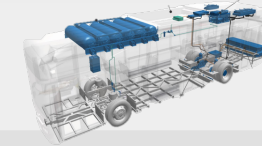
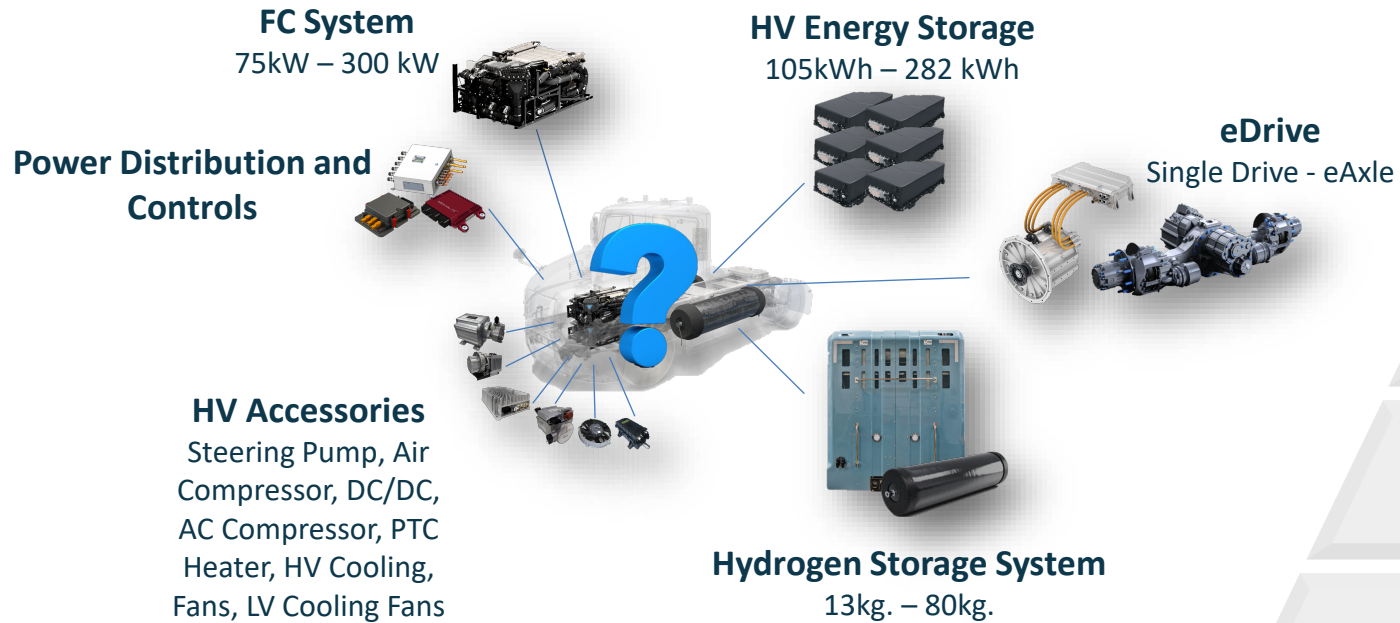

Bus

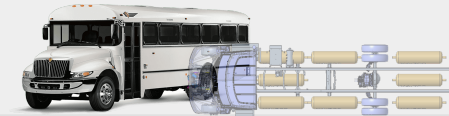

Class 6 Truck & Passenger bus



Refuse



Class 8 Dump Truck



Class 8 Drayage / Mid & Long Haul

Key Notes

- Chassis, eDrive, battery, and HSS agnostic
- Easily configure for a wide range of applications
- Engineered for streamlined integration to different vehicle platforms

Flexible, Industry Friendly MD/HD Solutions

CLASS 8 TRUCK

FC System (SP75)
75kW – 300 kW

Power Distribution and Controls

Hydrogen Storage System
13kg – 24kg,
350 bar – 700 bar

Battery
105 kWh – 282 kWh

eDrive
Single Drive - eAxle

HV Accessories
Steering Pump, Air Compressor, DC/DC, AC Compressor, PTC Heater, HV Cooling, Fans, LV Cooling Fans

Power: 350 kW – 510 kW
Range: 200 – 450 Miles
Fuel Cell: 150 kW - 300kW
Chassis Agnostic

TRANSIT BUS

FC System (SP75)
75kW – 150 kW

Air Conditioning

Battery
105 kWh – 282 kWh

Hydrogen Storage System
13kg – 40kg,
350 bar – 700 bar

eDrive
Single Drive - eAxle

HV Accessories
Steering Pump, Air Compressor, DC/DC, AC Compressor, PTC Heater, HV Cooling, Fans, LV Cooling Fans

Power: 300kW
Range: 200 – 300 Miles
Fuel Cell: 75 kW - 150kW
Chassis Agnostic
Repower 'Kit' ready

REFUSE TRUCK

FC System (SP75)
75kW – 150 kW

Power Distribution and Controls

Hydrogen Storage System
13kg – 24kg,
350 bar – 700 bar

Battery
105 kWh – 210 kWh

eDrive
Single Drive - eAxle

HV Accessories
Steering Pump, Air Compressor, DC/DC, AC Compressor, PTC Heater, HV Cooling, Fans, LV Cooling Fans

Power: 285 kW – 350 kW
Range: 200+ Miles
Fuel Cell: 75kW – 150 kW
Loader: Front, Side
Chassis Agnostic
Repower 'Kit' ready

CLASS 6 - CONCEPT

FC System (SP75)
75kW – 150 kW

Power Distribution and Controls

Hydrogen Storage System
13kg – 48kg,
350 bar – 700 bar

Battery
105 kWh – 210 kWh

eDrive
Single Drive - eAxle

HV Accessories
Steering Pump, Air Compressor, DC/DC, AC Compressor, PTC Heater, HV Cooling, Fans, LV Cooling Fans

Power: 285 kW – 350 kW
Range: 200+ Miles
Fuel Cell: 75kW – 150 kW
Chassis Agnostic
Repower 'Kit' ready

High Impact Applications

Class 8 Truck

FC System (SP75)
75kW – 300 kW



Hydrogen Storage System
13kg. – 24kg.
350 bar – 700 bar

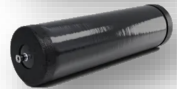

Power Distribution and Controls

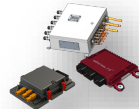

Power: 350 kW – 510 kW
Range: 200 – 450 Miles
Fuel Cell: 150 kW - 300kW
Chassis Agnostic

HV Accessories
Steering Pump, Air Compressor, DC/DC, AC Compressor, PTC Heater, HV Cooling, Fans, LV Cooling Fans



Battery
105 kWh – 282 kWh



eDrive
Single Drive - eAxle



Refuse Truck

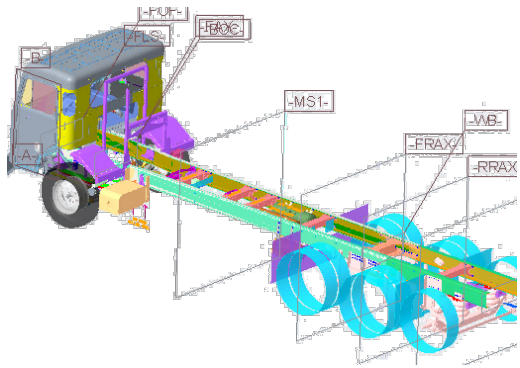

FC System (SP75)
75kW – 150 kW



Hydrogen Storage System
13kg. – 24kg.
350 bar – 700 bar



Power Distribution and Controls



HV Accessories
Steering Pump, Air Compressor, DC/DC, AC Compressor, PTC Heater, HV Cooling, Fans, LV Cooling Fans

Power: 285 kW – 350 kW
Range: 200+ Miles
Fuel Cell: 75kW – 150 kW
Loader: Front, Side
Chassis Agnostic
Repower 'Kit' ready



Battery
105 kWh – 210 kWh

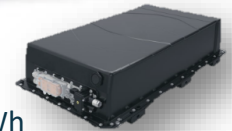

eDrive
Single Drive - eAxle



Upcoming Projects – Refuse Truck

Project Highlights

- Develop and deploy a **HFCE refuse truck**
- **One-year operational demo** in the South Coast Air Basin (WM, CR&R, Riverside, LA)
- **Fueling by Utility Global; UCI independent data collection and third-party validation**

NOTE: Project in contacting phase, expected start Q1 2026



Why is this important

- Immediate **Nox and PM elimination** in urban communities
- Demonstrates **cost-effective repower pathway** to ZE compliance
- Provides **scalable pathway for large fleets adoption**

Why FCEV

- Constant start/stop
- Heavy loads
- Long Idle times
- PTO



FCEV optimized for refuse duty:
Stop-and-go efficiency, eliminates idle and PTO
parasitic losses, instant torque, fast refueling

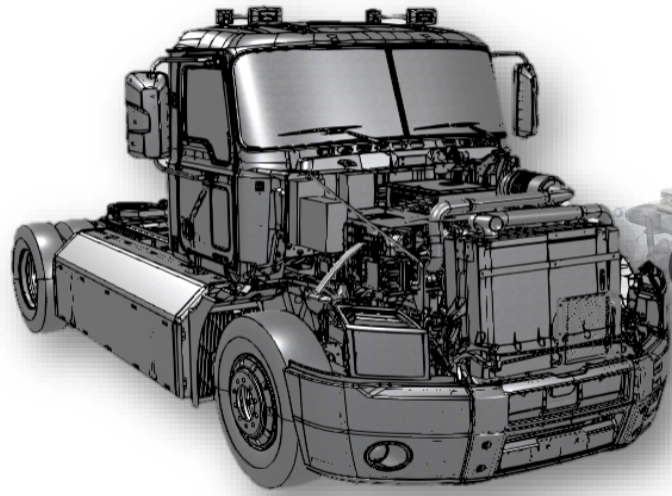

IDEA



CONCEPT



REALITY



Integrating Zero-Emission Vehicles into Waste Collection

CALIFORNIA AIR RESOURCES BOARD – DRIVE FORWARD TRUCK FORUM | MARCH 2026

Julia Mangin



About Recology

27
Collection
Operations

19
Transfer
Stations

11
Material
Recovery
Facilities

8
Composting
Facilities

2
Active
Landfills

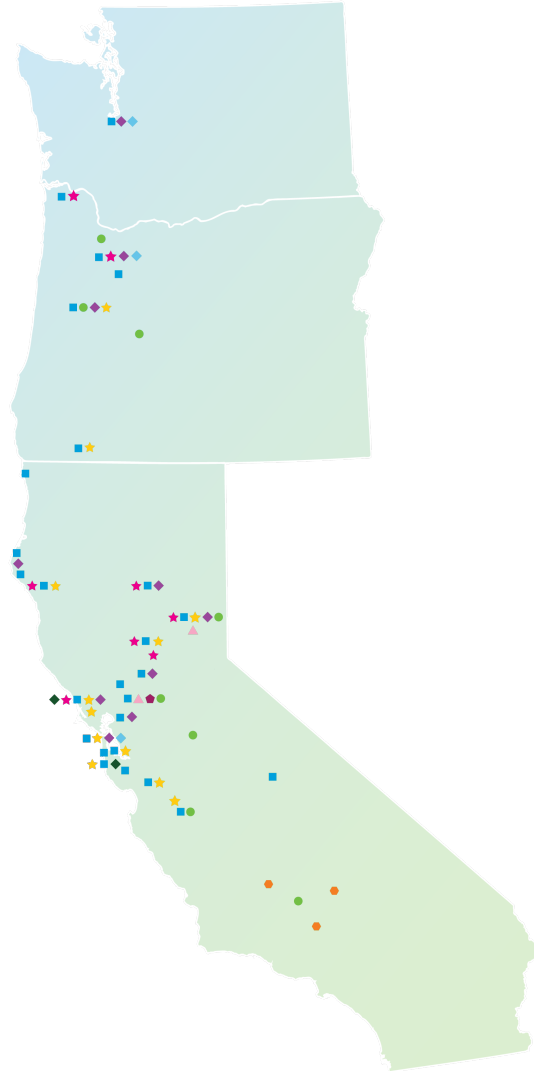

100%
Employee-owned

4.2k
Employee-owners

2,600
Vehicles operated

Piloting the First Hydrogen Fuel Cell Refuse Collection Vehicle



Transition Planning

Partnered with the Center for Transportation and the Environment (CTE) to conduct Total Cost of Ownership (TCO) Assessment for ZEV transition.

- Suitability
- Feasibility
- Costs
- Timeline



Battery Electric Feasibility

- Light-duty and limited medium-duty vehicles feasible in near term
- Some heavy-duty vehicles nominally feasible in future years (2032+)
- Some heavy-duty and specialty vehicles infeasible for BEV → FCEV more suitable

BEV Not Suitable
BEV Suitable, Neither Nominal nor Strenuous Requirement Feasible
Nominal Requirement Feasible for BEV
Strenuous Requirement Feasible for BEV

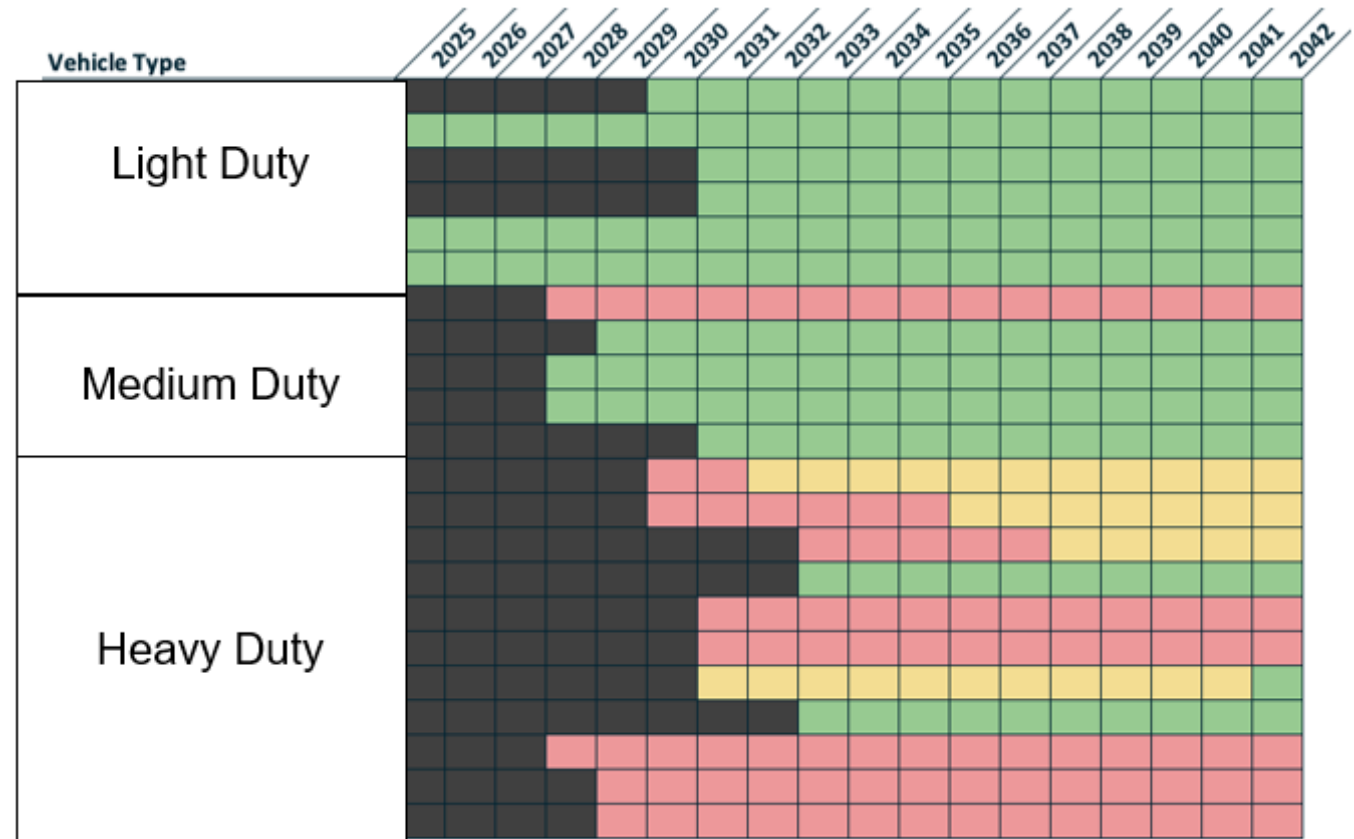

Total Cost of Ownership (TCO)



TCO Assessment found that ZEV Fleet Transition would result in

27%

increase in total fleet costs

Payload Penalty

BEVs: 1.8 – 6-ton payload penalty

HFCEV: 2.8-ton payload penalty

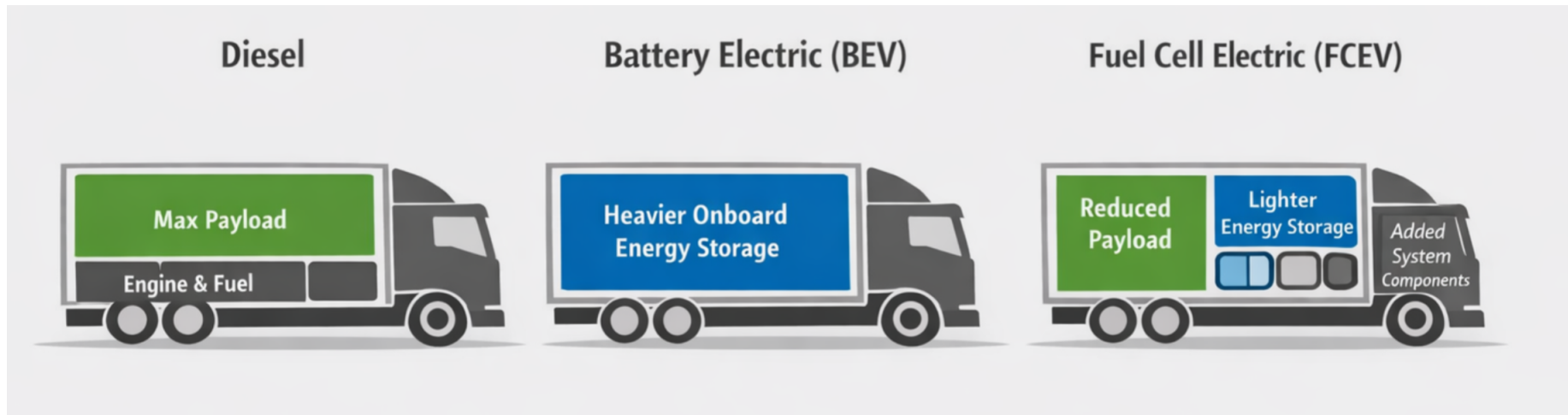

Reduced payload = more trips, higher costs, and operational constraints.



Questions?





RAVEN

Drive Forward Truck Forum: Biomass Hydrogen to Hydrogen Fleets

March 9, 2026
Matt Murdock

Raven™ – Powering a New World

Hydrogen Production Methodologies

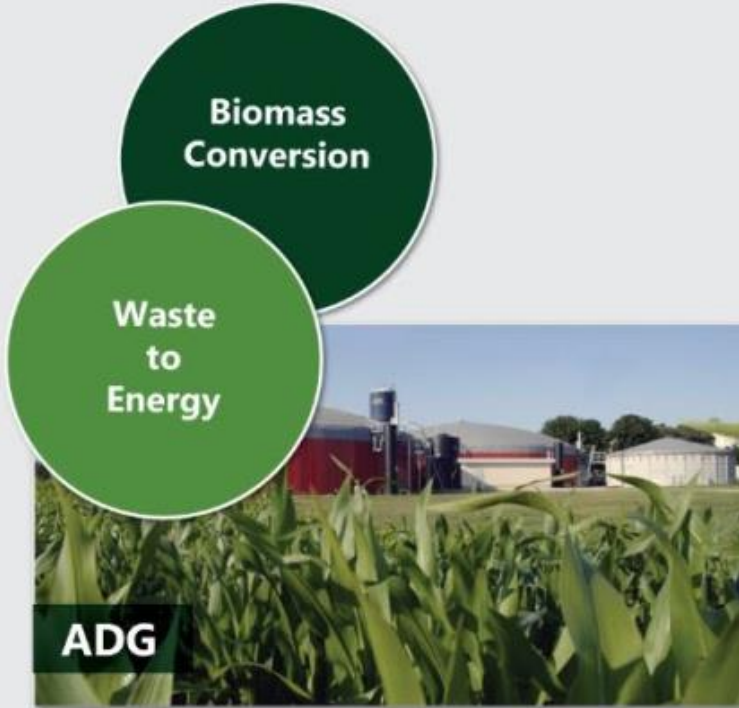
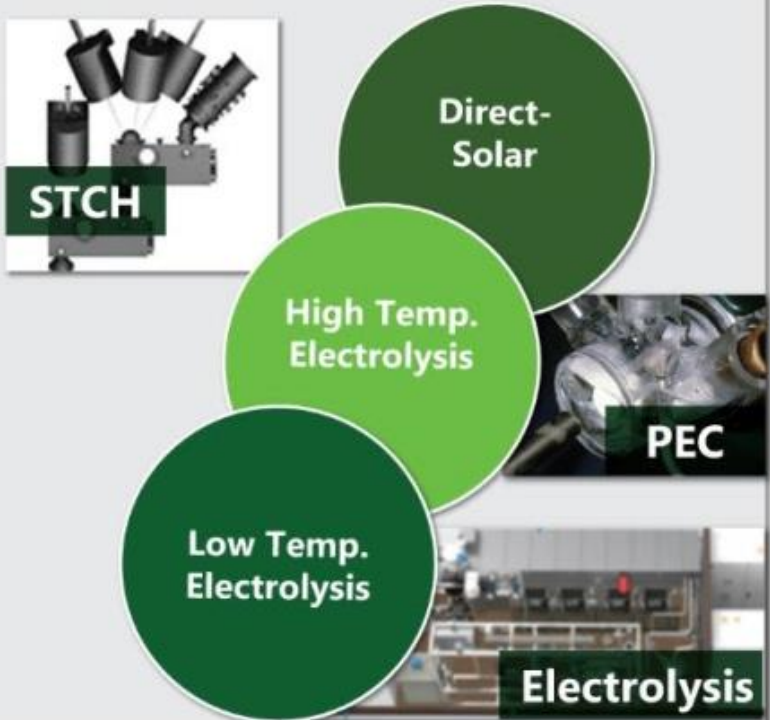
FOSSIL RESOURCES	BIOMASS/WASTE	H ₂ O SPLITTING
<ul style="list-style-type: none">• Low-cost, large-scale hydrogen production with CCUS• New options include byproduct production, such as solid carbon  <p>The diagram for Fossil Resources shows two overlapping circles: a dark blue circle labeled 'Coal Gasification with CCUS' and a light blue circle labeled 'Natural Gas Conversion with CCUS'. Below these is a photograph of an industrial facility with tall chimneys emitting smoke, labeled 'SMR' in a black box at the bottom left.</p>	<ul style="list-style-type: none">• Options include biogas reforming and fermentation of waste streams• Byproduct benefits include clean water, electricity, and chemicals  <p>The diagram for Biomass/Waste shows two overlapping circles: a dark green circle labeled 'Biomass Conversion' and a light green circle labeled 'Waste to Energy'. Below these is a photograph of a cornfield in the foreground and an industrial facility in the background, labeled 'ADG' in a black box at the bottom left.</p>	<ul style="list-style-type: none">• Electrolyzers can be grid-tied, or directly coupled with renewables• New direct water-splitting technologies offer longer-term options  <p>The diagram for H₂O Splitting shows three overlapping circles: a dark green circle labeled 'Direct-Solar', a light green circle labeled 'High Temp. Electrolysis', and a dark green circle labeled 'Low Temp. Electrolysis'. To the left is a photograph of a solar tower plant labeled 'STCH' in a black box. To the right is a photograph of an electrolyzer cell labeled 'PEC' in a black box. At the bottom right is a photograph of an industrial electrolyzer facility labeled 'Electrolysis' in a black box.</p>

Hydrogen Production Methodologies – Carbon Intensity

Waste-to-hydrogen pathways can achieve very low lifecycle carbon intensity when paired with avoided landfill emissions.

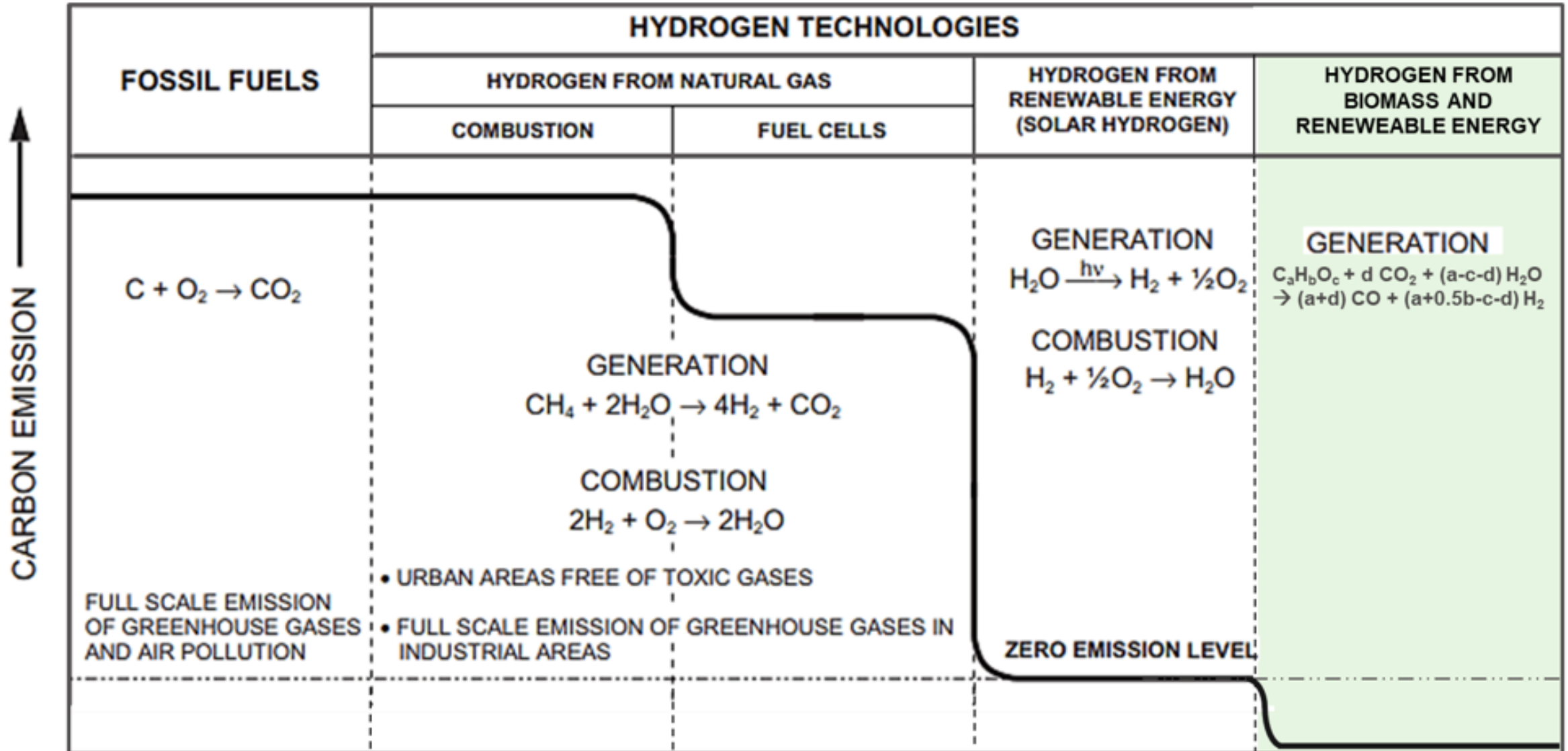

Climate Benefits of Converting Biomass to Hydrogen

- When landfilled, organic waste streams generate methane – a short-lived climate pollutant that contributes significantly to near-term warming. Diverting these materials and converting their energy into hydrogen both prevents future methane formation and produces a zero-emission fuel for transportation.
- Lifecycle modeling of the Richmond waste stream indicates that converting compost overs* to hydrogen can deliver greater greenhouse-gas reductions per ton than conventional composting pathways for the same residual material.
- Under the Richmond modeled case, net greenhouse-gas reductions were approximately three times greater than those achieved through composting of the same residual biomass stream.

*Compost overs are the coarse, woody materials (like branches, twigs, or large organic debris) that do not break down during a standard composting cycle.

Data sources: IPCC AR6; Climate & Clean Air Coalition; Raven Richmond lifecycle modeling.

Raven Richmond Biomass Conversion Facility (70 wtpd)

RAVEN



Milestones

- ✓ Feedstock agreement
- ✓ Offtake agreement
- ✓ FID
- ✓ Tier 1 Registration
- ✓ Land Easements
- ✓ Grid Connection
- ✓ CEQA IS/MND
- ✓ Community support
- ✓ Labor Endorsement
- ✓ EJ/NGO Endorsement
- ✓ Richmond CUP
- ✓ SWFP → BCF
- ✓ Article II Compliance
- ✓ ATC Issued

Feedstock

Green & Wood Waste

Input Capacity

70-99 wtpd

Output Capacity

~ 7,000 kg/day H₂
(SAE J2719 grade)

Partners + Offtake



Waste Collection → Hydrogen → Refuse Fleet

- Compost overs and construction and demolition wood sourced from regional waste streams
- Processed under CA Biomass Conversion Facility framework
- Hydrogen produced at ~7,000 kg/day
- Compatible with return-to-base refuse truck fueling
- May be sized to match return-to-base refuse fleet demand.



West Contra Costa Sanitary Landfill (Richmond, CA)



SR-1 Electric Rotary Reformer

Converts solid waste into syngas and bio-carbon.

Core Advantages:

- Electric heating for precise heat control
- Non-catalytic
- 95% cold-gas efficiency
- Lower temps + steam = no tars or slag
- Robust, modular design



SR-2 Electric Steam Reformer

Converts methane-rich syngas to high-purity H₂.

Core Advantages:

- Electric heating for precise heat control
- Non-catalytic
- >97% CH₄ conversion
- Destroys sulfur & nitrogen impurities
- Lower pressure than traditional SMR



Distributed modular configuration
Compatible with on-site fueling depots
Non-combustive, Electric heating
Strong Technology and IP

Together, SR1 and SR2 enable non-combustion hydrogen production from solid waste – cleanly, efficiently, and at commercial scale.

Five Garbage Trucks per Day → Transportation-Scale Hydrogen

In Raven's case, diverting approximately 23,000 metric tons of organic waste from landfill would produce roughly 2,000 metric tons of hydrogen per year – equivalent to about 120 million miles of passenger fuel-cell travel or more than 13 million miles of Class 8 fuel-cell truck operation – and avoid 4,750+ metric tons of CO₂e emissions.

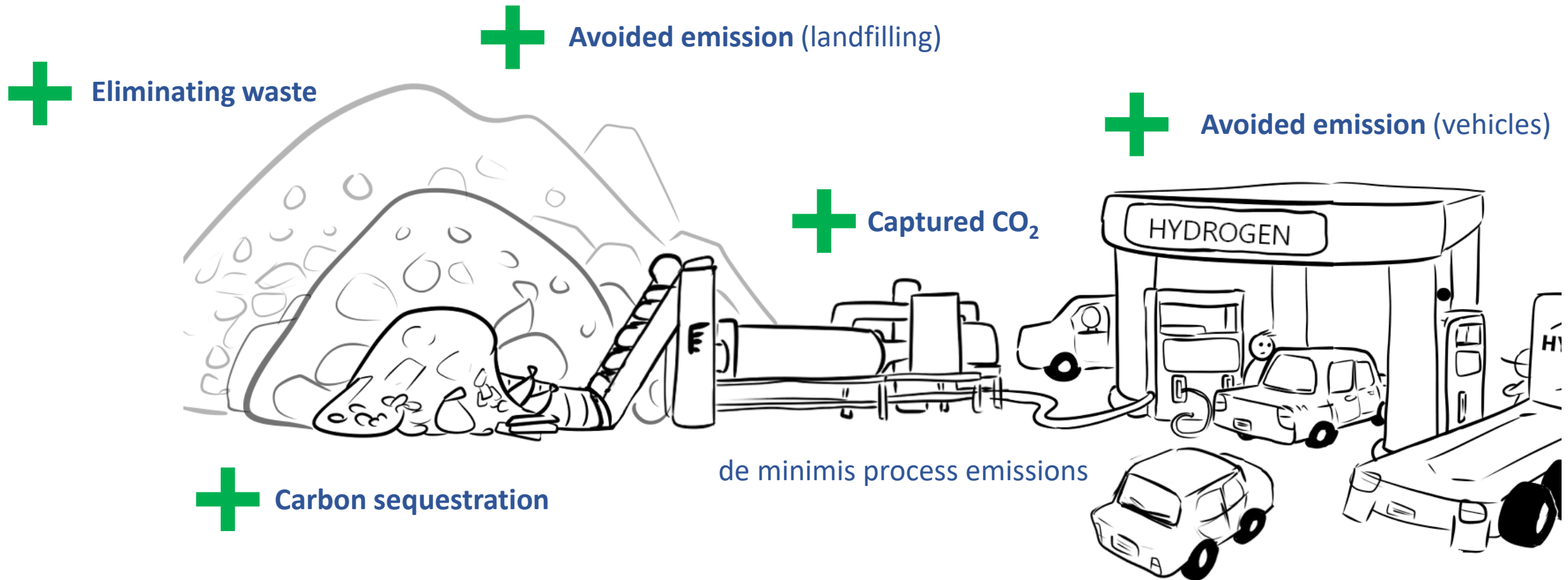

Disclaimer

This presentation is provided by Raven SR, Inc. solely for informational and educational purposes in connection with regional sustainability and clean-energy planning efforts. It is intended to share technical, environmental, and policy information about hydrogen production pathways and related technologies relevant to Contra Costa County's Climate Action Plan goals.

This material does not constitute an offer, solicitation, or recommendation for any commercial transaction, investment, or partnership. It should not be interpreted as marketing, financial advice, or endorsement of any specific project or technology.

All data, projections, and examples are presented for discussion and planning purposes only. While care has been taken to ensure accuracy, Raven SR makes no representation or warranty, express or implied, as to the completeness or reliability of the information contained herein. Figures, emissions data, and lifecycle values are subject to change as regulatory guidance, models, and scientific understanding evolve.

This presentation may include statements about potential environmental or community benefits of various hydrogen technologies. Such statements are illustrative only and are not intended to compare, rank, or disparage other companies, technologies, or stakeholders operating in the region.

Any forward-looking statements are based on current assumptions and should not be interpreted as guarantees of future performance or outcomes. Raven SR assumes no obligation to update or revise this material.

By reviewing this presentation, attendees acknowledge that its contents are non-confidential and informational, and that Raven SR is not offering or promoting any financial product or service.

Landfill Gas /
Biogas →

H₂O →

H2Gen[®]

ECONOMIC INDUSTRIAL DECARBONIZATION

Biogenic Off-gas

Economic Low-Carbon Hydrogen from Biogas

Mike Iannelli, Vice President Global Biogas

Hydrogen →

Utility Global

Owners, Projects and Company Presence



Owners

Ara Built to Decarbonize.™

apg

aramco

ArcelorMittal

SAMSUNG

ONTARIO POWER GENERATION

SAINT-GOBAIN

UTILITY

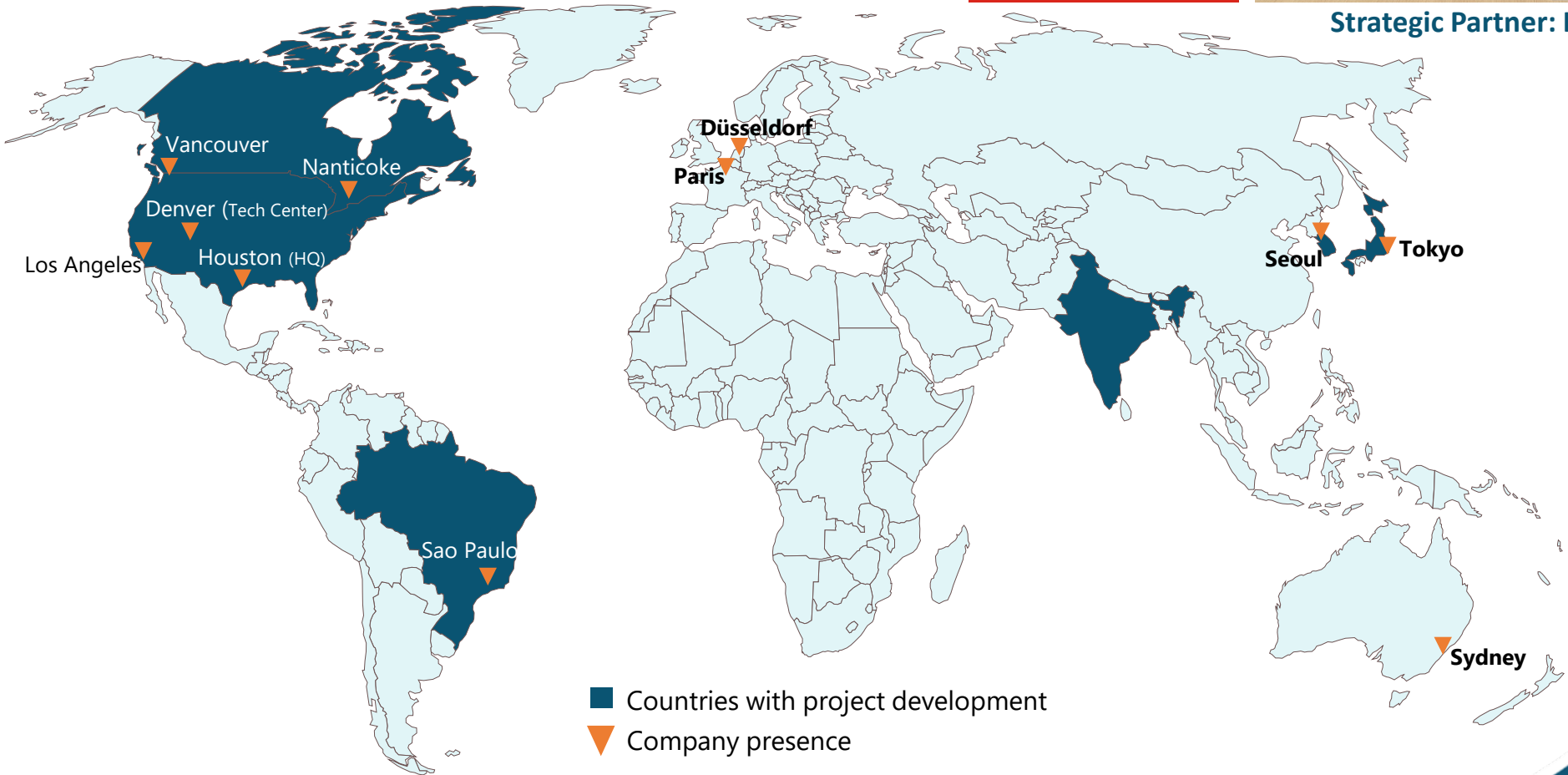

Decentralized Clean Hydrogen Production for Mobility Using Biogas

H2Gen® Economic Solution Enables H₂ Production for Mobility



Utility's Hydrogen Advantages

- Energy source: **landfills, wastewater plants, dairy farms, food waste** and other biogases
- H2Gen plants are highly **reliable, affordable, modular, providing decentralized, on-site, low-to-negative CI H₂**
- **Low capex, OpEx and footprint Hydrogen without requiring expensive RNG upgrading and PSA gas separation**
- **High project certainty** - no power needed for hydrogen production (no power-gen infrastructure & permits)

California Biogas Sites Flaring Methane

140 Sites Targeted Today Capable of Producing 2 to 4 TPD of H2



Created by Fabio Rinaldi From the Noun Project

Combined Heat & Power

Generation of electricity by CHP for onsite power and heat requirements; typically used in WWTPs

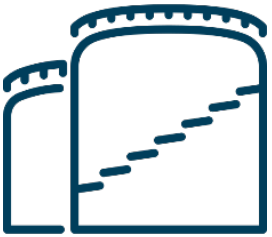

Biogas Producer



Upgrade to Biomethane

Biogas that has been upgraded to RNG grid injected; high value incentives from RECs and LCFS programs; market is saturated due to limited CNG demand growth making future project economics challenging



Created by Dahlia nur aini From Noun Project

Flaring biogas

Numerous biogas sites where CHP and RNG are not economically viable or possible, so biogas is flared. This is particularly prevalent with many of the State's landfills – **These sites can be leveraged to produce cost effective H2**

Biogas Sites Flaring



Project Champion: California's First Dairy Biogas to H₂ Project

Project Overview: 3.0 TPD from Dairy Biogas

- Utility and Maas Energy Works (MEW) are jointly developing a project in California
- Project Agreement was signed in September 2025
<https://media.utilityglobal.com/news/utility-and-maas-announce-agreement-to-develop-dairy-digester-to-hydrogen-mobility-project-in-california>
- MEW is installing anaerobic digesters at four dairy farms currently under contract, and anticipates piping biogas to a central Utility hydrogen plant

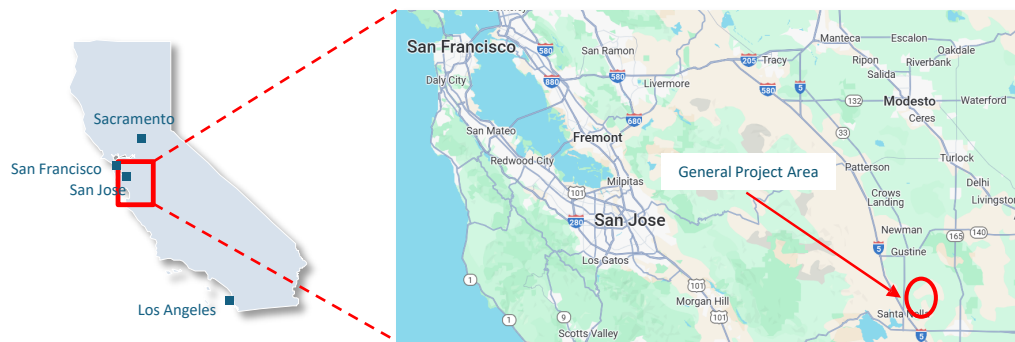

- H₂ will be produced at fuel cell grade and sold to the mobility market, with excellent market access via truck to both the Bay Area and Sacramento
- Ongoing offtake process with high-quality counterparties for long-term commitments
 - Anticipated CI over -800 gCO₂e/MJ driving significant interest across range of offtakers, with signed LOIs for offtake
 - H₂ pick up at plant gate and compression to 520 bar via tube trailer filling

Champion: Leading U.S. Dairy RNG Producer

- Maas Energy Works is the **leading biogas developer in California**
 - Tens of constructed and operational dairy digesters, with dozen operational RNG plants
 - Privately owned with experience in operations and maintenance
- Experience with **all facets of project design, permitting, and construction** in California
 - Largest dairy digester cluster in the world
 - Dairy biogas pipeline injection facilities in California
 - CalRecycle-licensed food waste co-digestion facilities, with numerous successful restarts of previously abandoned third-party digesters

Milestone and Completion Date Timeline



Utility's Strategy for California Distributed Hydrogen Network

30 TPD of Low-Carbon Hydrogen by 2031

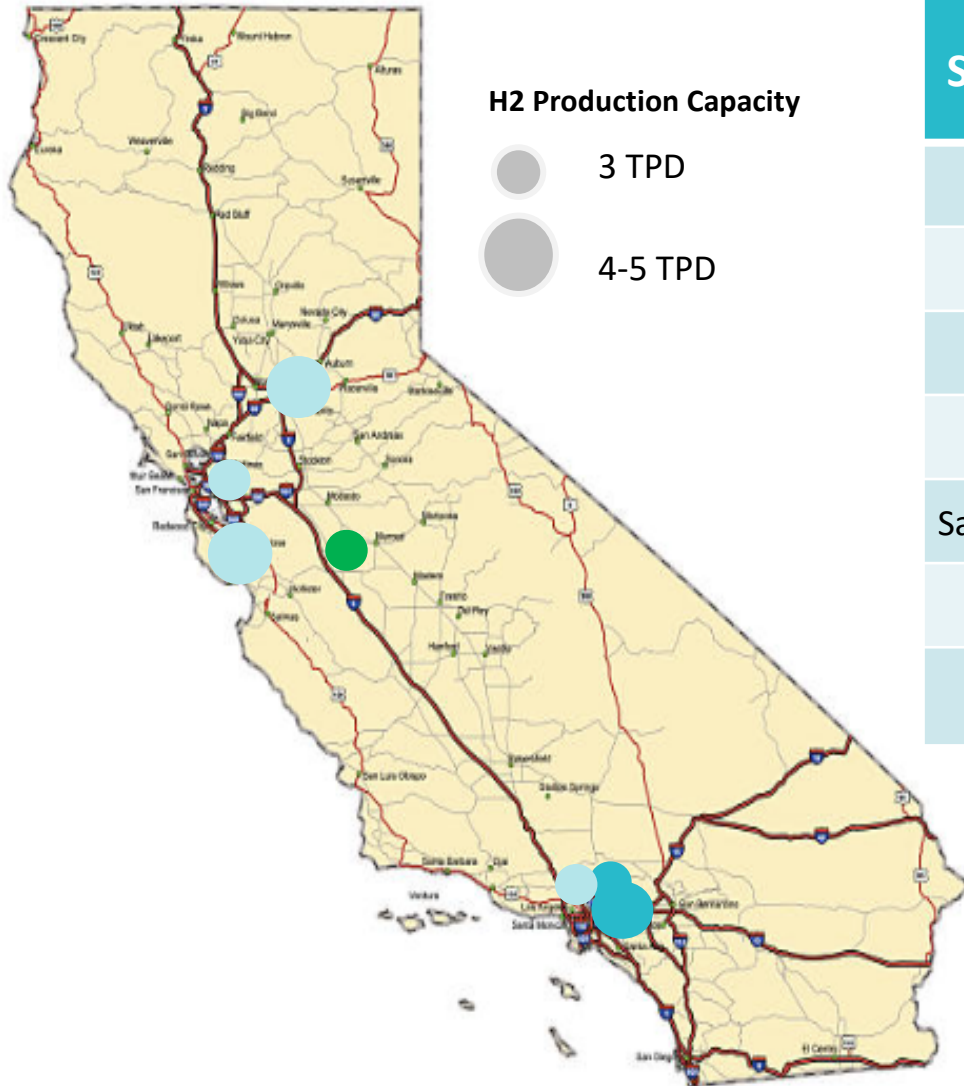

Site Location	Project Partner	Status	Operational	Feedstock
Merced	Maas Energy	PreFEED	2028	Dairy
LA Basin	Confidential	Feasibility	2029	Landfill
LA Basin	Confidential	Planning	2029	Landfill
LA Basin (TBD)	TBD	Planned	2030	Food Waste
Sacramento (TBD)	TBD	Planned	2030	Landfill
East Bay (TBD)	TBD	Planned	2030	Landfill
South San Francisco (TBD)	TBD	Planned	2031	Landfill

- Closely deployed H2 production in grid constrained urban centers
- Aligned to support truck deployments / refuse collection fleets

Achieving Low-Carbon Hydrogen at Lower than Gray H2 Cost

Targeting \$6.00/kg H2 at plant gate post incentives

Competitive price

- H2GEN[®] supports highly competitive market price, providing a pathway to near term low-carbon hydrogen production in the State

Enables heavy-duty demand growth

- Utility's production model can achieve near diesel parity today, which fleets require for ZEV adoption

Flexible and cost-effective

- H2GEN[®] requires minimal power grid connection, allowing deployment in highly grid-constrained regions

Utility's Target H2 vs. Current Gray H2 (\$/kg)

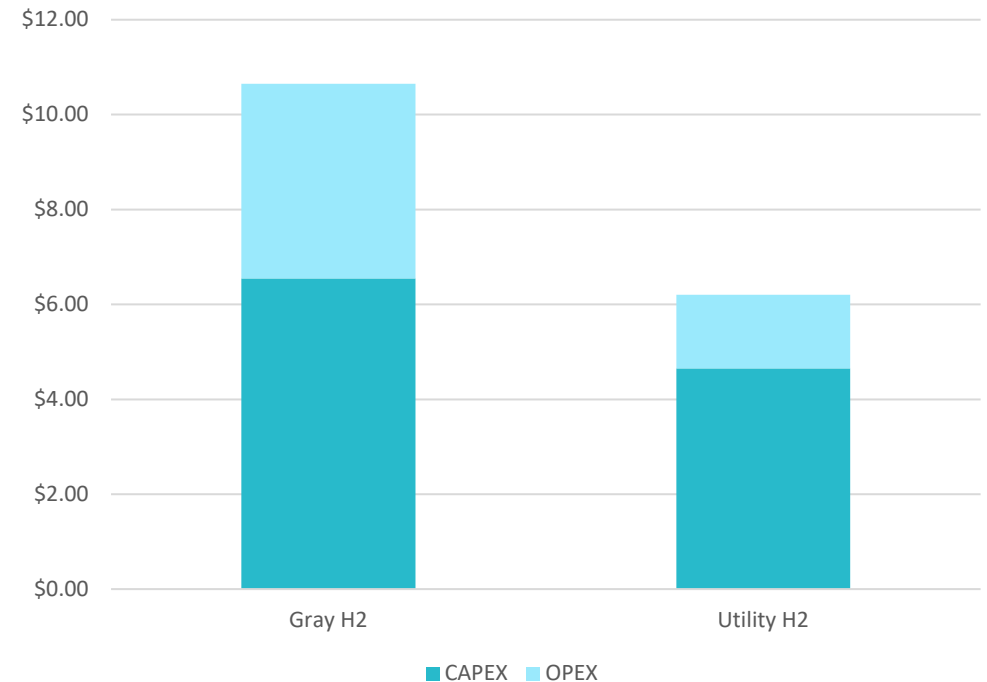

Thank You

www.utilityglobal.com

Contacts

Mike Iannelli – VP Global Biogas
miannelli@utilityglobal.com

Cory Shumaker – Director Hydrogen
Business Development
cshumaker@utilityglobal.com



Focused Discussion

- Refuse and recycling fleet challenges and must-haves
 - Zero-emission vehicle expectations
 - Operation and maintenance - in-house or contracted?
- Challenges or uncertainties with fuel cell truck technology
 - Timeline for developing and scaling relative to potential demand
 - Economics of achieving scale
- Status of hydrogen production technologies from waste resources
 - Biogas clean up and reformation to hydrogen
 - Reliability and O&M

Recap and Next Meeting

- Recap of today's discussion
- 2026 Drive Forward Truck Forum Infrastructure Meetings, 1:00 – 3:00

May 18

September 14

December 7

- Co-chairs seeking input on topics for May, September and December meetings
 - Leslie Goodbody: leslie.goodbody@arb.ca.gov
 - Lisa McGhee: lmcghee@ttruck.com
 - Bradley Northrop: bradley.northup@carlsbadca.gov

Upcoming Meetings and Events

- Project Design and Permitting Efficiency – Critical Updates for MDHD Charging Developers
 - GoBiz lead, March 11, 2026, 1:00-2:30, [Webinar Registration – Zoom](#)
- CARB Heavy Duty Incentives Workshop, Hybrid
 - March 25: [Funding Plan for Clean Transportation Incentives | California Air Resources Board](#)
- Zero-Emission Showcase + Ride and Drive Event, San Diego, April 29
 - [Zero Emissions Showcase + Ride & Drive – Zero-Emissions Showcase + Ride & Drive : San Diego, CA](#)
- Drive Forward Fleet workshop planned for summer 2026
 - [Drive Forward Fleet | California Air Resources Board](#)