

**Executive Order VR-203-AD and VR-204-AD
Balance Phase II EVR System**

EXHIBIT 16

Liquid Condensate Trap Compliance Test Procedure

Definitions common to all certification and test procedures are in:

D-200 Definitions for Vapor Recovery Procedures

For the purpose of this procedure, the term "ARB" refers to the California Air Resources Board, and the term " ARB Executive Officer" refers to the ARB Executive Officer or his or her authorized representative or designate.

1. PURPOSE AND APPLICABILITY

This procedure is used to verify the automatic evacuation of the Liquid Condensate Trap (LCT), the Liquid Sensor Alarm, as well as Visual and Audible Alarm. This procedure provides a method to determine compliance with the LCT requirements specified in ARB Executive Orders VR-203 and VR-204 and any subsequent amendments or revisions.

2. PRINCIPLE AND SUMMARY OF TEST PROCEDURE

This test procedure provides a method to determine the compliance of LCTs. Gasoline is added to the LCT until the Liquid Sensor activates an alarm. The gasoline in the LCT is then allowed to be evacuated until the Liquid Sensor Alarm has cleared.

3. BIASES AND INTERFERENCES

- 3.1. There can be no Phase I deliveries to the gasoline underground storage tank (UST) while performing this test.
- 3.2. To ensure that the gasoline level is below the vapor tube on the side of the Turbine Pump the gasoline level in the UST (connected to the LCT) must be below its 90 percent capacity level.

4. EQUIPMENT

- 4.1. Five (5) gallon gasoline container and funnel or other method of pouring gasoline into the LCT.

5. PRE-TEST PROCEDURE

- 5.1. Notify the Certified Unified Program Agency (CUPA) prior to conducting this test procedure. A list of CUPAs can be found at www.calepa.ca.gov/CUPA/Directory/default.aspx.
- 5.2. No dispensing is allowed to any vehicle for the duration of the test.

- 5.3. Prior to testing, turn off the 87 grade turbine pump that is connected to the LCT suction line. (This is to keep from evacuating the LCT when adding gasoline for testing.)
- 5.4. Record LCT capacity in Form 1. A metal tag specifying LCT capacity is installed above the Fuel Entry Point (See Figures 16-1 and 16-2). If LCT capacity tag is not installed, the LCT is not in compliance with Exhibit 2 specifications.

6. TEST PROCEDURE

- 6.1. Remove plug or cap on Fuel Entry Point installed at the suction riser of the LCT. Add gasoline through the open Fuel Entry Point (see Figures 16-1, 16-2 and 16-3). Note: Gasoline may be added at one of the dispenser risers in lieu of the LCT Fuel Entry Port.

For a typically sized LCT (9.9 gallons) this will be approximately 2 to 3 gallons of gasoline because the Liquid Sensor is installed at 2 inches from the bottom of the LCT (See Figure 16-4). For larger LCTs do not introduce more gasoline than 10 percent capacity of the LCT.

- 6.2. Verify the Liquid Sensor activates an Audible and Visual Alarm at the tank monitoring system control panel (control panel) and obtain a printout of the alarm/sensor status (see attached Appendix A for instructions on printing out the sensor alarm report for the Veeder Root and INCON tank monitoring systems). Record results on Form 1 and attach printout of sensor status. After verification you may silence the Alarm.

If there is **No** Audible and Visual Alarm at the control panel within five (5) minutes, the LCT is not in compliance with Exhibit 2 specifications.

- 6.3. Verify Liquid Evacuation: Turn on the turbine pump that is connected to the LCT. Maintain this turbine pump operation (running) until the Liquid Sensor Alarm has cleared (i.e. turned off). Record results on Form 1 and attach printout of sensor status (see attached Appendix A for instructions on printing out the sensor alarm report for the Veeder Root and INCON tank monitoring systems).

Note: To keep this turbine pump running you may need to authorize more than one fueling point during the testing period. For a typical LCT capacity of 10 gallons, it will take approximately 10 to 15 minutes to evacuate 3 gallons of gasoline.

If the Liquid Sensor Alarm **does not clear**, (gasoline is not being evacuated), the LCT is not in compliance with Exhibit 2 specifications.

7. POST TEST PROCEDURE:

If plug or cap on the LCT Fuel Entry Point was removed, reinstall using pipe thread sealant (e.g. pipe dope) **and** gasoline compatible PTFE tape (e.g. Teflon® tape, plumber's tape, or tape dope). If gasoline was introduced at one of the dispenser risers, reconnect the dispenser vapor piping to the riser.

8. REPORTING RESULTS

Record all alarms and evacuation test results, as well as any failures on Form 1. Ensure all printouts from control panel are attached to Form 1. Districts may require the use of alternate forms provided that the alternate forms include the same parameters as identified in Form 1.

FIGURE 16-1
Typical Configuration

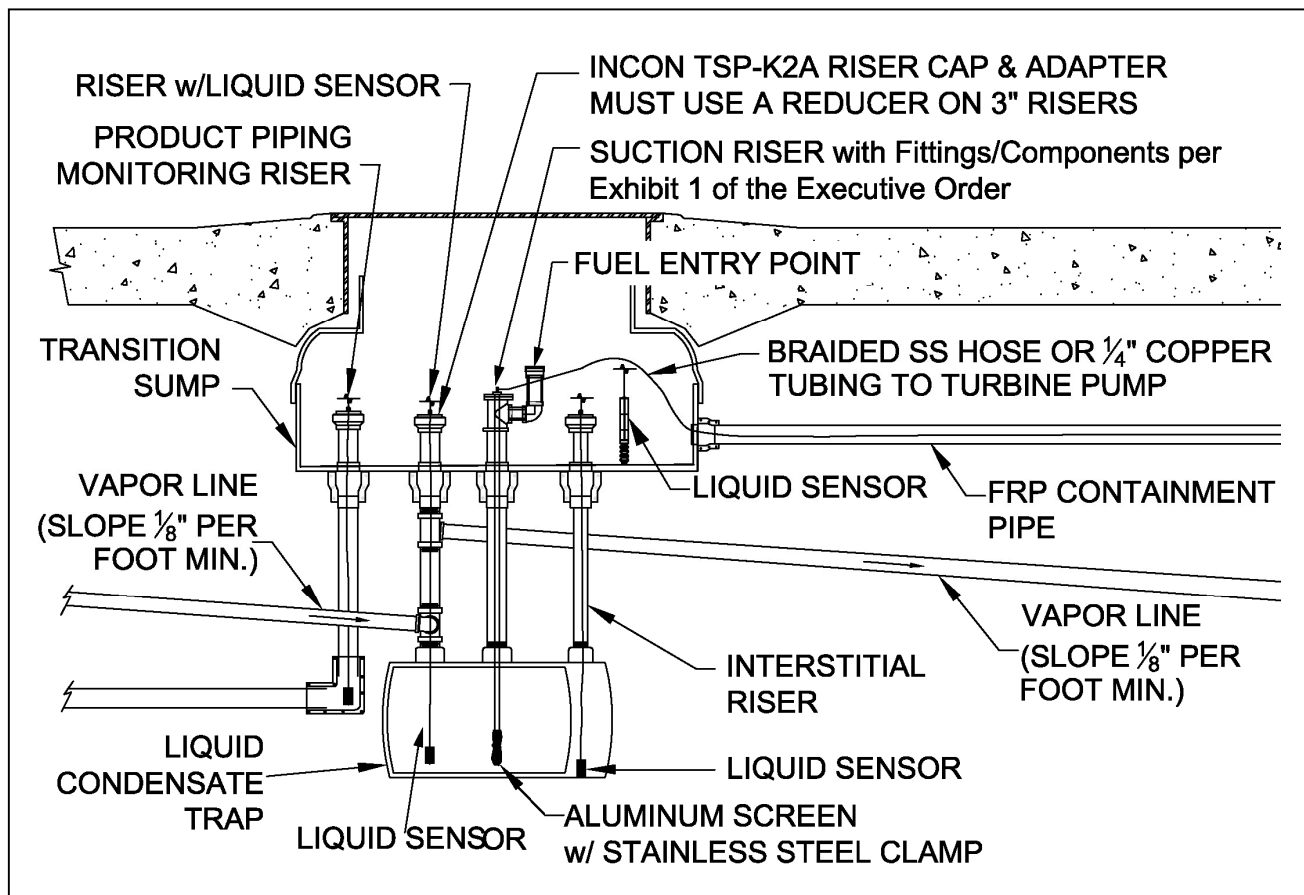

FIGURE 16-2
Open Fuel Entry Point

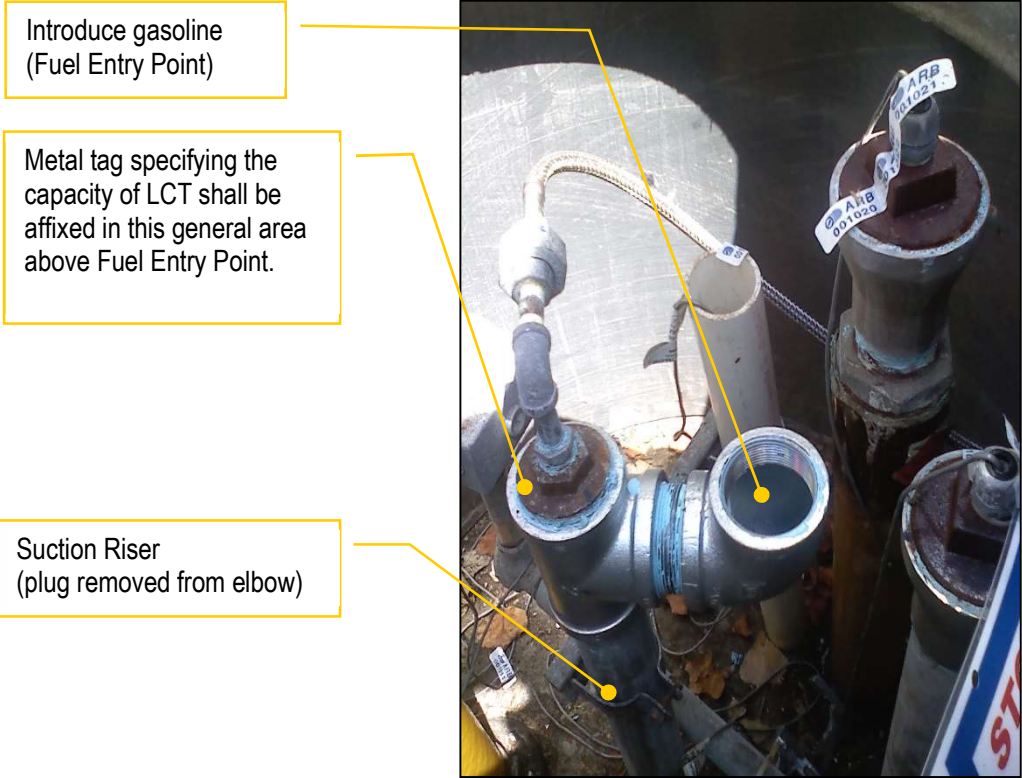
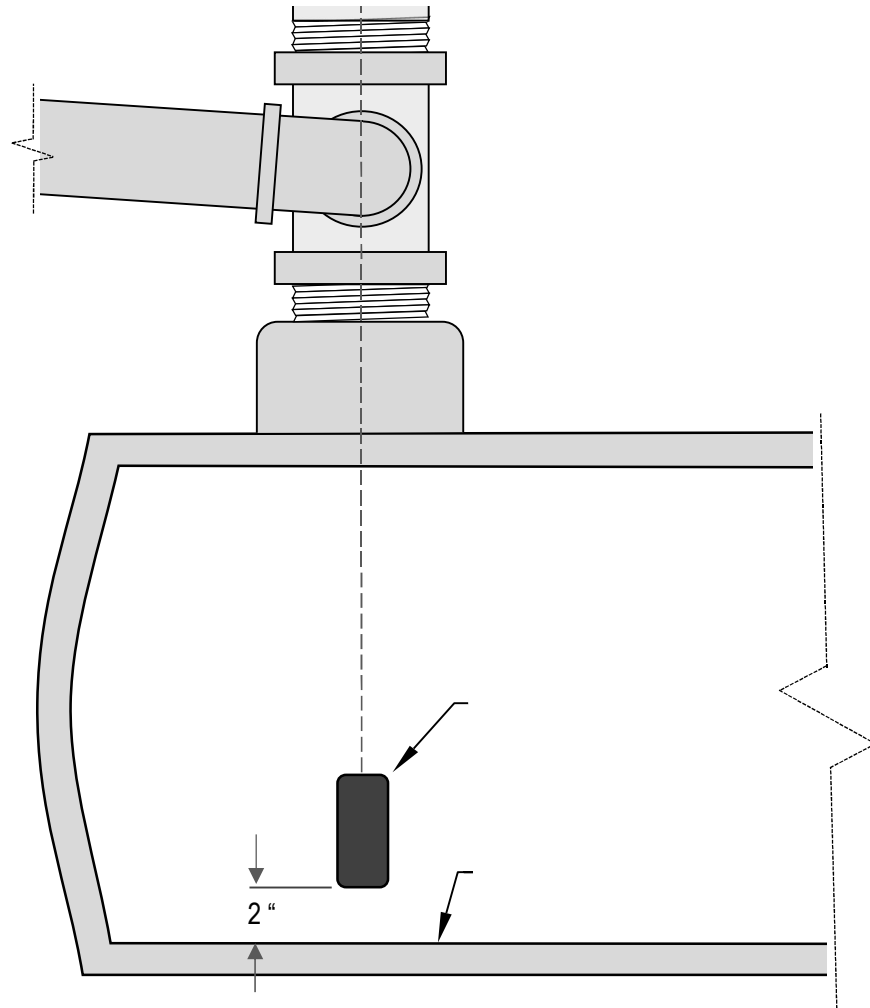

FIGURE 16-3
Adding Gasoline through Open Fuel Point



FIGURE 16-4
Liquid Sensor Height Setting



**Form 1
VR-203 and VR-204 AD**

**Required Data When Conducting the
Liquid Condensate Trap Compliance Test Procedure**

Date: _____

Liquid Condensate Trap Compliance Test Form	
Service Company Name	Service Company's Telephone
Date of Test	Certification #'s (as applicable) <u>Healy Tech. Cert. #</u>
Station Name and Address	<u>District Training Cert. #</u> <u>ICC Cert. #</u>
Service Technician (print name and sign)	District Permit #
	Capacity of LCT in gallons

Applicable Step Number	Requirement	Verification (please circle)
Step 3.2	Gasoline below 90 percent capacity level of UST?	Yes No
Step 5.3	Was tag with LCT capacity present above Fuel Entry Point?	Yes No
Step 6.2	Did Liquid Sensor activate an Audible Alarm as well as a Visual Alarm at control panel within five minutes after adding gasoline? (Attach alarm/sensor status printout to this Form.)	Yes No
Step 6.3	Did LCT evacuate and Sensor Alarms clear? (Attach alarm/sensor status printout to this Form.)	Yes No

APPENDIX A

Veeder Root LCT Liquid Sensor Alarm Report

There are many manufacturers of UST tank monitoring systems. The following are steps to print the Liquid Sensor Alarm History Report from the UST tank monitoring console for the Veeder-Root TLS-350 series and TLS-450PLUS Tank Monitoring System.

Note: When the LCT liquid sensors were originally programmed into the Tank Monitoring System the title given to those sensors included "LCT" in the name (for example if Liquid Sensor 10 is the High Level Liquid Sensor for the LCT it could have been named "L10 LCT High Liquid".)

Veeder-Root TLS 350 Series Console

Liquid Sensor Alarm History Reports are a record of the last three alarms for the liquid sensor selected. To print a liquid Sensor Alarm History Report **and** if Maintenance Tracker is enabled go to Exhibit 18 for instructions (to temporarily disable Maintenance Tracker) and then return to instructions below.

How to Obtain Liquid Condensate Trap (LCT) Alarm Print-Outs

Step	Button Pushed	Number of Times Pushed	Readout
1	MODE	Multiple, Push until readout on right is shown	SETUP MODE
2	FUNCTION	Multiple, Push until readout on right is shown	LIQUID SENSOR SETUP
3	PRINT *	Once	LIQUID SENSOR SETUP
4	MODE	Multiple, Push until readout on right is shown	DIAG MODE
5	FUNCTION	Multiple, Push until readout on right is shown	ALARM HISTORY REPORT
6	STEP	Multiple, Push until readout on right is shown	L#: ALARM HISTORY
7	TANK/SENSOR	Multiple, until you reach the liquid sensor number assigned to the High Liquid Level in the LCT.	EXAMPLE: L10:LCT HIGH LIQUID
8	PRINT**	Once	EXAMPLE: L10:LCT HIGH LIQUID
9	MODE	Multiple, Push until readout on right is shown	MM DD, YYYY HH:MM:SS: XM ALL FUNCTIONS NORMAL

* A printout will be generated displaying a read-out of all liquid sensors. Find the liquid sensor number assigned to the LCT.

** A printout will be generated displaying the last three alarms for the Liquid sensor assigned to the LCT.

APPENDIX A CONTINUED

Veeder-Root TLS-450PLUS LIQUID SENSOR ALARM REPORT

Follow the Figures below to print a Sensor Report for LCT Alarm

Figure 1

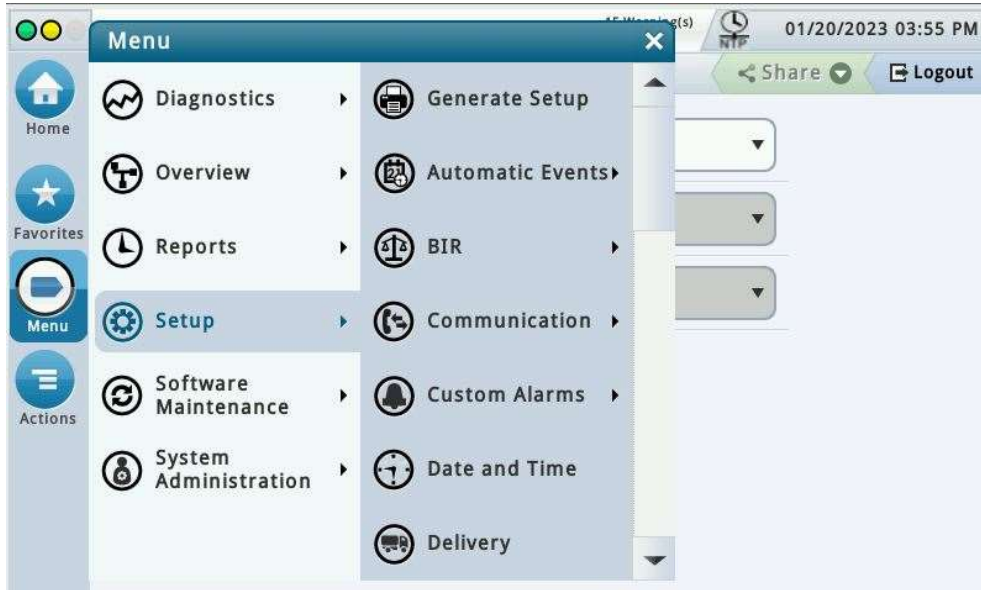
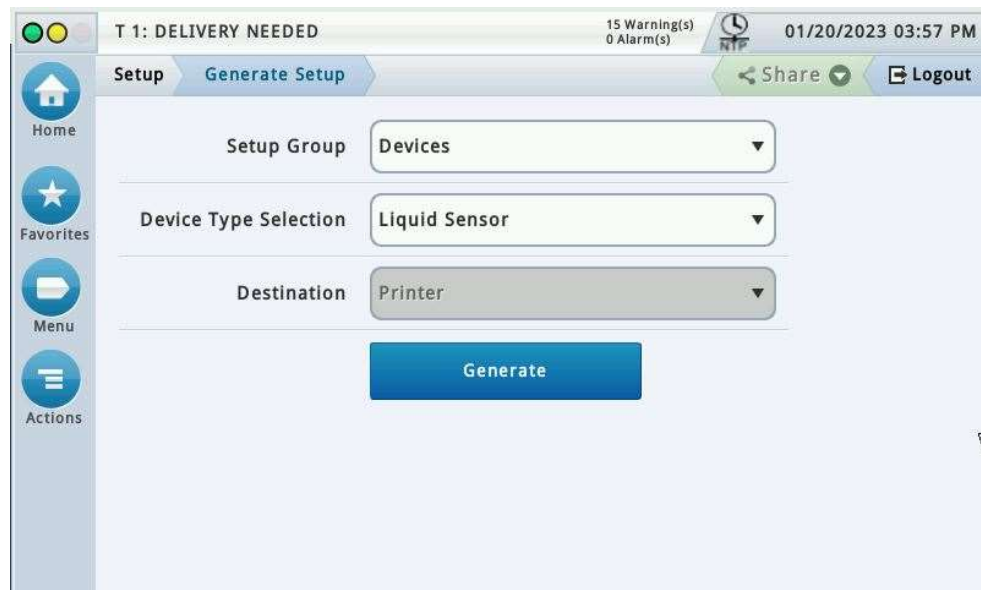

Figure 2



APPENDIX A Continued

Figure 3

```
-----  
*** DEVICE SETUP - LIQUID SENSOR ***  
-----  
  
--- LIQUID SENSOR 1 ---  
CONFIGURED:          ENABLED  
LABEL:               Annular space  
ADDRESS:             B1.S1.11  
MODEL:               Tri-State(Single Float)  
CATEGORY:            Annular Space  
  
--- LIQUID SENSOR 2 ---  
CONFIGURED:          ENABLED  
LABEL:               Turbine sump  
ADDRESS:             B1.S1.12  
MODEL:               Tri-State(Single Float)  
CATEGORY:            STP Sump  
  
--- LIQUID SENSOR 3 ---  
CONFIGURED:          ENABLED  
LABEL:               Annular space  
ADDRESS:             B1.S1.13  
MODEL:               Tri-State(Single Float)  
CATEGORY:            Annular Space  
  
--- LIQUID SENSOR 4 ---  
CONFIGURED:          ENABLED  
LABEL:               Turbine sump  
ADDRESS:             B1.S1.14  
MODEL:               Tri-State(Single Float)  
CATEGORY:            STP Sump  
  
--- LIQUID SENSOR 5 ---  
CONFIGURED:          ENABLED  
LABEL:               Annular space  
ADDRESS:             B1.S1.15  
MODEL:               Tri-State(Single Float)  
CATEGORY:            Annular Space  
  
--- LIQUID SENSOR 6 ---  
CONFIGURED:          ENABLED  
LABEL:               LCT High Liquid  
ADDRESS:             B1.S1.16  
MODEL:               Tri-State(Single Float)  
CATEGORY:            Other
```

APPENDIX A
(continued)

INCON LCT LIQUID SENSOR ALARM REPORT

Follow the figures below to print a Sensor Report for LCT Alarm (Do not select Alarm History):

Figure A-1

Press 'Home' button until you reach the screen show below. Select Print Option

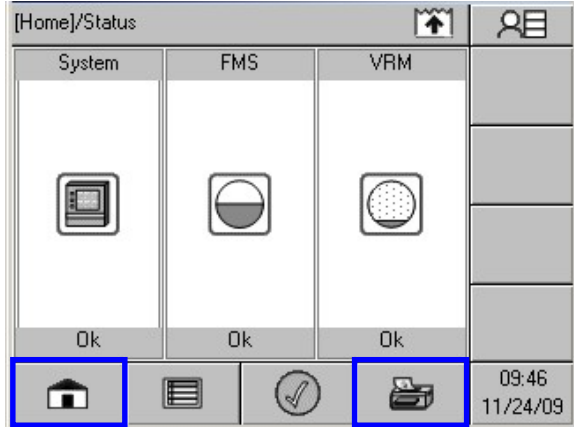

Figure A-2

Select the FMS Option

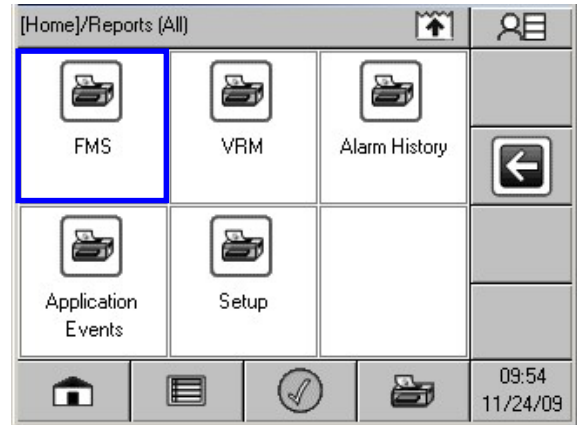

Figure A-3

Select 'Sensor' Option. You may need to press the 'scroll' button to see the 'Sensors' selection on screen

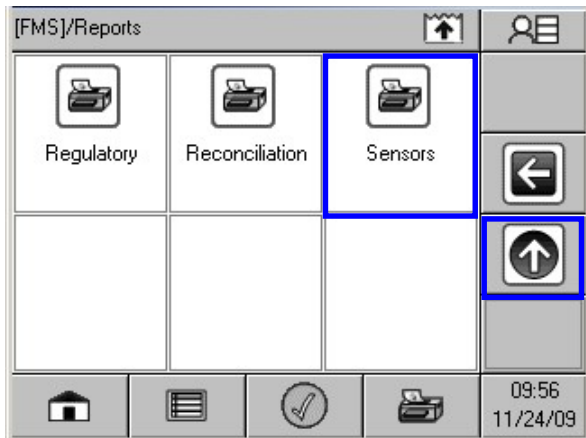

Figure A-4

Select Print Option

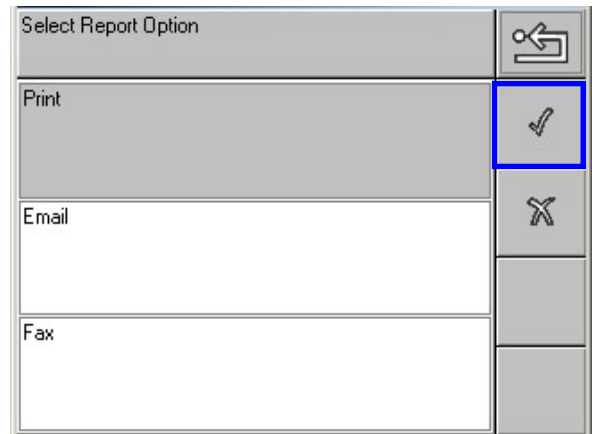

Figure A-5

Select "Last Available" Option. If your alarm does not show, select 'Last 30 days' or current month and your Option. Be patient, Printer takes a few minutes to print.

