

FINAL PROJECT REPORT

The Port of Los Angeles Zero- and Near-Zero-Emission Freight Facilities “Shore to Store” Project

Grant Number: G17-ZNZE-10

Port of Los Angeles Agreement No. 19-3639

May 10, 2023



Prepared by:

Primary Author(s):

Jacob Goldberg, Project Manager, Port of Los Angeles
Teresa Pisano, Supervising Manager, Port of Los Angeles
Laura Hunter, Starcrest Consulting Group, LLC
Lauren Dunlap, Starcrest Consulting Group, LLC
Brett Grothen, Project Manager, Kenworth Truck Company
Arron Paddock, Project Manager, Kenworth Truck Company
Kevin Goss, Program Manager, Toyota Motor North America
Jason Lustbader, National Renewable Energy Laboratory
Joe Sawa, Hydrogen Project Manager, Shell Hydrogen
Jared Leventhal, Hydrogen Project Manager, Shell Hydrogen
Giles Pettifor, Environmental Manager, Port of Hueneme
National Renewable Energy Laboratory, Center for Integrated Mobility Sciences:
Cory Sigler, Research Engineer; Andrew Kotz, Senior Research Engineer; Michael
Lammert, Senior Research Engineer; Matthew Jeffers, Research Engineer; and
Jason Lustbader, Group Manager, Advanced Vehicles and Charging Infrastructure

Grant Number: G17- ZNZE-10

Agreement Number: 19-3639

Prepared for:

California Air Resources Board

Ryan Murano
Project Manager

**Additional Funding Grant provided by
South Coast Air Quality Management District**

Maryam Hajbabaei
Program Supervisor

TABLE OF CONTENTS

	Page
Abstract	1
Executive Summary.....	2
Section 1: Purpose and Approach.....	5
1.1 Project Purpose.....	5
1.1.1 Project Goal	5
1.1.2 Project Objectives.....	5
1.2 Project Approach.....	6
1.3 Activities Performed.....	6
1.3.1 Task 1 Project Administration	6
1.3.2 Task 2 Design, Construction, and Commissioning of Hydrogen Infrastructure	7
1.3.3 Task 3 Ocean Truck Fleet Design, Build, and Support	8
1.3.4 Task 4 Yard Tractors and Charging Infrastructure.....	9
1.3.5 Task 5 Technology Demonstrations.....	9
1.3.6 Task 6 Data Collection and Analysis	9
Section 2: Design, Build and Construct.....	10
2.1 On-Road Trucks Demonstration.....	10
2.1.1 On-Road Vehicle Demonstration Overview.....	10
2.1.2 Fuel Cell Electric Truck Overview	12
2.1.3 Technical Specifications	13
2.1.4 FCEV Equipment Commissioning Improvements and Lessons Learned	21
2.1.5 Simulation Model and Vehicle Performance Forecast	25
2.1.6 Testing and Validation	27
2.2 Hydrogen Infrastructure	31
2.2.1 Renewable Hydrogen and Environmental Impact	31
2.2.2 Ontario Station	31
2.2.3 Wilmington Station	37
2.2.4 Port of Long Beach Portal Station	40
2.3 Port of Hueneme Project.....	42
2.3.1 Yard Tractors	42
2.3.2 Yard Tractor Infrastructure.....	44
2.3.3 E-Crane Charger Infrastructure.....	44
2.4 Battery-Electric Forklifts.....	46
Section 3: Data Collection & Analysis.....	47
3.1 Data Collection Test Plan	47
3.1.1 On-Vehicle Data Collection	47
3.1.2 Operation and Maintenance Data Collection.....	48
3.1.3 Infrastructure	48
3.1.4 Data Collection Summary	48
3.2 Baseline Data Collection.....	48

3.2.1 Baseline Class 8 Tractor Drayage Duty Cycles.....	49
3.2.2 Baseline Yard Tractor Operation	52
3.2.3 Baseline Truck Operation and Maintenance	54
3.3 Ocean Trucks.....	60
3.3.1 Ocean Trucks Duty Cycle.....	64
3.3.2 Ocean Truck Maintenance	67
3.3.3 In-Use Demonstration Experience (i.e., Operator Surveys).....	70
3.3.4 Discussion of Baseline and Advanced Vehicles	73
3.4 Hydrogen Stations.....	77
3.4.1 Station Energy Consumption and Fuel Dispensed.....	78
3.4.2 Hydrogen Fueling Events.....	80
3.5 Battery-Electric Yard Tractors.....	83
3.5.1 Electric Yard Tractor Operational Data Summary	84
3.5.2 In-Use Demonstration Experience (i.e., Operator Surveys).....	88
3.6 Battery-Electric Forklifts.....	88
Section 4: Findings and Recommendations	90
4.1 Summary of Results	90
4.1.1 Hydrogen Infrastructure.....	90
4.1.2 Ocean Truck Demonstration Fleet.....	91
4.1.3 Battery-Electric Yard Tractors	92
4.1.4 Battery-Electric Forklift.....	92
4.1.5 Project Costs and Schedule Overview.....	92
4.1.6 Project Benefits	93
4.2 Lessons Learned	95
4.3 Significant Challenges	96
4.4 Findings and Recommendations	96
Section 5: Outreach Events.....	97
5.1 Project Outreach Efforts.....	98
5.1.1 Kenworth Fuel Cell Electric Truck in Washington, D.C.	98
5.1.2 Ocean Fleet Marathon.....	99
5.1.3 California Air Resources Board Public Open House	100
5.1.4 South Coast AQMD Technology Showcase.....	101
5.1.5 Clean Truck Fee Kick-Off Event.....	102
5.1.6 Port of Los Angeles Debut of Ocean Trucks & Fueling Stations	103
5.2 Project "Afterlife"	104

LIST OF FIGURES

Page

Figure 1. Five Ocean Fleet FCEVs at the Shell Hydrogen Station.....	8
Figure 2. Ocean Truck climbing the summit of Pikes Peak in Colorado.....	11
Figure 3. Ocean Trucks Layout of Major Components.....	13
Figure 4. Fuel Cell Layout.....	14
Figure 5. Dual Fuel Cell Assembly.....	15
Figure 6. Dual PCU Assembly.....	15
Figure 7. High-Voltage Battery Assembly.....	16
Figure 8. High-Voltage Battery Integrated into Hydrogen Storage Cabinet.....	16
Figure 9. Eaton HVPD Box.....	17
Figure 10. JDES PD400 Single Inverters.....	17
Figure 11. Eaton 4-Speed Transmission.....	18
Figure 12. Inline Dual Cascadia Motion Motors.....	19
Figure 13. Bel Power DC-DC Converter.....	19
Figure 14. CAN Architecture.....	20
Figure 15. High-Voltage Interlock System Design.....	22
Figure 16. Hybrid Display.....	23
Figure 17. Snapshot of Simulation Model.....	26
Figure 18. Intended Operating Area.....	27
Figure 19. Ocean Truck at PACCAR Technical Center.....	28
Figure 20. Ocean Truck at Pikes Peak.....	29
Figure 21. Fleet Distance Traveled by Year (per Truck).....	30
Figure 22. Fleet Distance Traveled by Year (all trucks).....	30
Figure 23. Aerial Photo of the Ontario Station Construction.....	33
Figure 24. Photo of the Ontario Station.....	34
Figure 25. Project Truck at the Ontario Station.....	36
Figure 26. Aerial Photo of the Wilmington Station.....	38
Figure 27. Photo of the Wilmington Station.....	39
Figure 28. Project Truck at the Wilmington Station.....	40
Figure 29. Kalmar Battery-Electric Yard Tractors.....	43
Figure 30. Electric Yard Tractors with Battery Pack Protection Covers.....	44
Figure 31. Q2 2022: Crane Vault Infrastructure Construction.....	45
Figure 32. Q1 2022: Liebherr 420 Hybrid-Electric Crane.....	46
Figure 33. Distribution of Daily Average Speed (left) and Daily Distance (right).....	50
Figure 34. Distribution of Fuel Economy (left) and Fuel Rate (right).....	51
Figure 35. Distribution of Daily Engine Run Time (left) and Percent Idle (right).....	51
Figure 36. Distribution of Daily Flywheel Energy (left) and Idle Energy (right).....	52
Figure 37. Distribution of Yard Tractor Average Speed (left) and Daily Distance (right).....	53
Figure 38. Distribution of Yard Tractor Fuel Economy (left) and Fuel Rate (right).....	53
Figure 39. Distribution of Daily Yard Tractor Engine Flywheel Energy (left) and Idle Energy (right).....	54
Figure 40. Fuel Price for Conventional Trucks, Fleet 1.....	55
Figure 41. Fuel Cost per Mile for Conventional Trucks, Fleet 1.....	55
Figure 42. Fueling Time of Day for Conventional Trucks, Fleet 1.....	56
Figure 43. Distance Between Fueling Events for Conventional Trucks, Fleet 1.....	56

Figure 44. Cargo Weight for Conventional Trucks, Fleet 1.....	57
Figure 45. Maintenance Cost per Mile for Diesel Trucks, Fleet 1	58
Figure 46. Fuel Price for All Conventional Trucks, Fleet 4.....	58
Figure 47. Distance Between Fueling Events for All Conventional Trucks, Fleet 4	59
Figure 48. Fueling Time of Day for All Conventional Trucks, Fleet 4.....	60
Figure 49. Daily Energy Intensity and Fuel Consumption of Ocean Trucks	62
Figure 50. Distribution of Daily Average Speed (left) and Daily Distance (right).....	64
Figure 51. Distribution of Fuel Economy (left) and Fuel Rate (right)	65
Figure 52. Distribution of Daily Run Time (left) and Percent Idle (right).....	66
Figure 53. Distribution of Stack Energy (left) and Daily Average Fuel Economy (right).....	67
Figure 54. Ocean Truck Maintenance Timeline	68
Figure 55. Scheduled and Unscheduled Maintenance Costs for Each Ocean Truck.....	69
Figure 56. Scheduled and Unscheduled Maintenance Costs for the Ocean Truck Fleet.....	69
Figure 57. Maintenance Costs by Category for Each Truck.....	70
Figure 58. Maintenance Costs by Category for the Ocean Truck Fleet.....	70
Figure 59. 30-Day and 90-Day Ocean Truck Survey Responses Compared.....	71
Figure 60. 30-Day and 90-Day Ocean Truck Detailed Survey Responses.....	72
Figure 61. Average Driving Speed and Daily Distance	73
Figure 62. Distribution of Engine Run Time and Idle Fraction (speed = 0, vehicle on)	74
Figure 63. Distribution of Fuel Economy and Fuel Rate	75
Figure 64. Distribution of Flywheel Energy and Energy Consumption Rate	76
Figure 65. Tailpipe and Production Emissions for CNG, Diesel, and H ₂ Vehicles	77
Figure 66. Monthly Hydrogen Station Electricity Cost.....	78
Figure 67. Monthly Hydrogen Compressed and Dispensed	79
Figure 68. Monthly Energy Consumption and Hydrogen Quantity for POLB Station.....	79
Figure 69. Monthly Energy Consumption and Hydrogen Quantity for Ontario Station.....	80
Figure 70. Hydrogen Station Fueling Time of Day.....	80
Figure 71. Hydrogen Station Fueling Day of Week.....	81
Figure 72. Hydrogen Station Fuel Quantity per Fill.....	81
Figure 73. Hydrogen Station Fuel Quantity vs. Fill Time	82
Figure 74. Hydrogen Station Fueling Rate.....	83
Figure 75. Kalmar Electric Yard Tractor	83
Figure 76. Heat Map of Hourly Distance Driven for POH 265.....	84
Figure 77. Heat Map of Hourly Distance Driven for POH 266	85
Figure 78. Total Distance Driven by Time of Day.....	85
Figure 79. Driving and Idling Time Fraction for Electric Yard Tractors.....	86
Figure 80. Driving and Idling Energy Fraction for Electric Yard Tractors.....	86
Figure 81. Daily Distance vs. Daily Total Driving Time for Electric Yard Tractors.....	87
Figure 82. Average Speed, Overall and Driving	87
Figure 83. Average Energy Consumption Rate, Overall and Driving	88
Figure 84. Monthly Hours of Use for Electric and Propane Forklifts	89
Figure 85. Monthly Electricity Use for Electric Forklifts Assuming 5 kWh/hour	89
Figure 86. Ocean Truck Showcased at Capitol Hill in Washington, D.C.....	99
Figure 87. Map Showing Fleet Route on Marathon Day.....	100
Figure 88. Ocean Fuel Cell Electric Truck Showcased at CARB Open House.....	101
Figure 89. Ocean Fuel Cell Electric Truck Showcased at Technology Showcase	101
Figure 90. Ocean Fuel Cell Electric Truck Showcased at Clean Truck Fee Kick-Off Event	102

LIST OF TABLES

	Page
Table 1. Project Truck Fleet Operation Summary	12
Table 2. Data Collection Summary – Baseline Vehicles.....	49
Table 3. Individual Ocean Truck Data Collection Summary Metrics	61
Table 4. Data Collection Summary – Ocean Vehicles	63
Table 5. Distance-Weighted Fuel Economy Metrics*	63
Table 6. Operational Statistics for Electric Yard Tractors	84
Table 7. Project Budget Expenditure Summary	93
Table 8. Project Funding Partners	93

ACRONYMS

California Air Resources Board (CARB)
California Energy Commission (CEC)
Carbon Dioxide (CO₂)
Controller Area Network (CAN)
Compressed Natural Gas (CNG)
Los Angeles Department of Water and Power (DWP)
Fuel Cell Electric Truck (FCET)
Fuel Cell Electric Vehicle (FCEV)
Heating, Ventilation and Air Conditioning (HVAC)
High-Voltage Power Distribution (HVPD)
Hydrogen Station Equipment Performance (HyStEP)
Liquefied Natural Gas (LNG)
National Renewable Energy Laboratory (NREL)
Original Equipment Manufacturer (OEM)
Oxides of Nitrogen (NO_x)
Port of Hueneme (POH)
Port of Los Angeles (POLA)
Port of Long Beach (POLB)
Shore to Store (S2S)
South Coast Air Quality Management District (South Coast AQMD)
Southern Counties Express (SCE)
Sulfur Oxides (SO_x)
Total Transportation Services Inc. (TTSI)
Toyota Logistics Service (TLS)
Toyota Motor North America (Toyota)
United Parcel Service (UPS)
Zero- and Near-Zero-Emission Freight Facilities (ZANZEFF)
Zero Emission (ZE)

Abstract

The City of Los Angeles Harbor Department (Harbor Department, POLA) partnered with Equilon Enterprises LLC (d/b/a Shell Oil Products US) (Shell), Toyota Motor North America (Toyota) and Kenworth Truck Company (Kenworth) partnered with the Port of Hueneme (POH), United Parcel Service (UPS), Total Transportation Services Inc. (TTSI), Southern Counties Express (SCE), Toyota Logistics Services (TLS), Air Liquide, National Renewable Energy Laboratory (NREL), Coalition For A Safe Environment, and the South Coast Air Quality Management District (South Coast AQMD) to introduce hydrogen (H₂) fuel into the Southern California drayage truck market by demonstrating near-commercial heavy-duty H₂ fuel cell electric trucks at and between freight facilities throughout the region, while continuing to lay the groundwork for battery-electric operations. The “Shore to Store” (S2S) project built on project team experience to help realize our vision of zero-emission freight operations in the future.

Ten Kenworth zero-emission Class 8 fuel cell electric trucks, integrated with Toyota’s fuel cell drive technology, were operated by UPS, TTSI, SCE, and TLS in revenue service. The demonstration fleet fueled at the S2S hydrogen fueling stations that were built in Ontario, California and Wilmington, California. An additional station at the Port of Long Beach (Portal Station) was available for fueling the fleet. Portal Station was supported by grants from the California Energy Commission (CEC) and South Coast AQMD and used as match funding for the S2S project. POH demonstrated two battery-electric yard tractors, and TLS demonstrated two zero-emission forklifts at their warehouse facility, showcasing elements of the entire supply chain operating on zero-emissions. This project showcased a snapshot of the zero-emission supply chain of the future, providing a model by which freight facilities can support zero-emission operations.

The Shore to Store project:

- Demonstrated the technical feasibility of zero-emission hydrogen fueled Class 8 heavy-duty trucks and electric cargo handling equipment in rigorous goods movement operation throughout the Southern California region.
- Cumulatively completed 59,212 miles of zero-emission operation, with 21,650 miles being driven in-service with the fleets, using hydrogen fuel cell electric Class 8 heavy-duty trucks.
- Operated zero-emission yard tractors for a total of 2,749.6 hours.
- Created direct localized emission reductions in designated disadvantaged communities, including those in zip codes 90220, 90247, 90248, 90731, 90744, 90802, 91761.
- For the 59,212 miles of zero-emission operation, the vehicles reduced emissions by an estimated total of 15.5 kg NO_x (0.163 g/km), 1.01 kg SO_x (0.0106 g/km), and 304.8 metric tonnes of CO₂e (3.2 kg/km) compared to the diesel baseline vehicles including both tailpipe emissions and the emission from producing the fuel sources.

Executive Summary

The “Shore to Store” (S2S) project was designed to develop and demonstrate the technical feasibility of zero-emission advanced technologies and supporting infrastructure in goods movement operation. S2S is part of a series of projects funded under the California Air Resources Board (CARB) Zero-and Near-Zero Emission Freight Facility (ZANZEFF) Projects, with the goal to, “support bold, transformative emission reduction strategies that can be emulated throughout freight facilities statewide.” The City of Los Angeles Harbor Department (Harbor Department, POLA) partnered with CARB, Equilon Enterprises LLC (d/b/a Shell Oil Products US) (Shell), Toyota Motor North America (Toyota) and Kenworth Truck Company (Kenworth) partnered with the Port of Hueneme (POH), United Parcel Service (UPS), Total Transportation Services Inc. (TTSI), Southern Counties Express (SCE), Toyota Logistics Services (TLS), Air Liquide, National Renewable Energy Laboratory, Coalition For A Safe Environment, and the South Coast Air Quality Management District (South Coast AQMD) to introduce hydrogen (H₂) fuel into the Southern California drayage truck market by demonstrating near-commercial heavy-duty H₂ fuel cell electric trucks in operation at and between freight facilities throughout the region, while continuing to lay the groundwork for battery-electric operations. The S2S project built on project team experience to help realize POLA’s vision of zero-emission freight operations in the future.

Successful implementation of this project demonstrated the technical feasibility of Class 8 fuel cell electric vehicle (FCEV) trucks in rigorous goods movement operation and expanded the use of zero-emission (ZE) equipment at warehouse facilities. This project resulted in direct localized emission reductions in designated disadvantaged communities, initiated a leap to zero-emission technology for a new class of on-road goods movement vehicles, expanded the use of zero-emission technology in off-road warehouse equipment, and provided multiple sources of hydrogen throughout the region.

For this project, Kenworth built 10 FCEVs in collaboration with Toyota. One of the primary project benefits was to demonstrate the development of a fleet of 10 FCEV trucks. The fleet provided a platform to compare truck performance and create a testbed for future development and improvement. The project team of skilled designers, developers, engineers, and test technicians provided invaluable knowledge and cumulative experience in prototyping and debugging the trucks during development and commissioning. In addition, the project yielded a fundamental understanding of ZE systems within the Class 8 freight transportation context.

Foundational infrastructure was designed and commissioned by Shell to support the operation of the ZE Ocean truck fleet. Two large-scale hydrogen stations were constructed for this project in Ontario and Wilmington, complemented by the Shell station at the Port of Long Beach (Portal Station). The Portal Station was developed under a grant from the California Energy Commission (CEC) and provided match share for S2S. The S2S project also leveraged a smaller station that was not funded or supported by this project but provided an important

linkage in the hydrogen fuel station network. The goal of the hydrogen infrastructure task was to finalize the engineering design, permitting, equipment procurement, construction, installation, testing, and commissioning of each of the project's hydrogen fueling stations.

During the demonstration, data were collected on the baseline and advanced Class 8 tractors in drayage service, hydrogen refueling station infrastructure, battery-electric yard tractors, and battery-electric forklifts.

From the 10 Class 8 FCEV trucks, nearly 22,000 miles of in-service miles and over 59,000 total miles of operational data were collected over 13 months consisting of 431 vehicle days. The vehicles conducted drayage operations across four different fleet operators. The analysis completed by NREL showed daily average distances ranged from 45 to 65 mi, and daily average fuel economy ranged from 6.1 to 8.2 MPGDE across the fleets. Average fuel consumption of the Ocean fleets varied between 0.150 and 0.187 kgH₂/mi. To provide baseline performance, NREL also collected 700,800 miles of operational data constituting 3,336 vehicle days from conventional Class 8 tractors performing similar operations. The baseline tractors in drayage service had an average daily distance of 210 miles and average fuel economy of 6.3 MPG.

The FCEV Ocean trucks performed their drayage operations with similar average fuel economy, on a diesel equivalent basis, compared to the conventional vehicles. This was achieved while driving on urban and congested roadways which is typically challenging for conventional vehicles due to the highly transient driving. It is important to note, however, that factors including differences in payload weight and proportions of loaded versus unloaded miles can have a significant impact on fuel economy. The Ocean trucks were driven shorter daily distances and at lower speeds on average than the baseline trucks. Given these shorter travel distances, the Ocean trucks also saw significantly lower daily average energy consumption and shorter daily engine run times than the baseline. However, the maximum daily driving distance, engine run time, and stack energy of each of the Ocean fleets suggest that these trucks are capable of meeting more demanding operational needs than what was observed in this study.

This demonstration showed the viability for Class 8 FCEVs in drayage operations of these distances and provided the immediate benefit of reducing direct localized emissions. It also showed that the first-generation technology used in these vehicles provides similar fuel economy performance, on a diesel equivalent basis, to conventional Class 8 diesel trucks, but with zero tailpipe emissions. The present state of this technology, along with performance improvements expected as the technology matures further and is optimized for heavy-duty trucks, indicates there is opportunity for further improvements in fuel economy over conventional vehicles in this type of operation.

As is typical with such a demonstration of a new technology, the availability of parts, technicians, and operators for these vehicles can create or prolong interruptions to their operation that can be attributed to the novelty of the application rather than considered inherent to the technology itself. Additionally, some of the Ocean trucks were temporarily

pulled from drayage operation for the purpose of other demonstrative events or efforts, creating additional days where the vehicle was not completing drayage operations that could be considered in service for the purposes of the analysis conducted in this study.

Hydrogen fueling stations that supported the operation of the Ocean trucks were also evaluated during the project. Ten months of hydrogen station performance data and approximately one year of individual fueling records were collected for Ontario and Portal fueling stations. The monthly throughput of hydrogen varied for both, but the total quantity of hydrogen compressed and dispensed was similar between the two stations, combined to total nearly 5,000 kg during the data collection period. To operate, Ontario and Portal stations consumed just under 41,000 kWh and 52,000 kWh of electrical energy, respectively, of which approximately 60% was used for hydrogen compression, and 35% was used for precooling prior to fueling. More than 1,100 fueling records were analyzed, indicating that hydrogen fueling was occurring almost exclusively on weekdays, primarily between 5:00 a.m. and 2:00 p.m. A significant fraction of the fueling events were less than 1.0 kg, indicating that many were restarts after failed attempts or partial fills. For fueling events greater than 1.0 kg, a typical fueling rate of approximately 1.5 kg/min was observed for the Ontario and POLB stations.

NREL analyzed a year of telematics data to characterize the operation of two electric terminal yard tractors and compared it to data captured from ten conventional diesel yard tractors over a month of operation. Combined, the electric yard tractors traveled almost 2,750 miles over 183 operational days, and the conventional yard tractors traveled 4,218 miles over 262 vehicle operational days. The average daily distance and average speeds were very similar between electric and conventional tractors. However, the electric tractors used less energy during the "idling" portion of their operation, which is a significant amount of time for yard tractors. The electric tractors consumed 3.7 kWh/mi, which is much lower than the baseline tractors' equivalent energy consumption rate of 13.9 kWh/mi (2.7 mpg), highlighting the energy efficiency benefit of the electric powertrain for this type of vehicle operation.

Based on typical hydrogen production pathways in the United States consisting of primarily steam methane reforming of natural gas for hydrogen production, the observed operation from the Ocean trucks would result in a 15% lower CO_{2e} emissions than the combined production and tailpipe emissions for diesel and compressed natural gas fuels. However, the hydrogen used in this project was produced from steam methane reforming of diverted methane emissions from dairy and swine manure. The lifecycle carbon intensity of this hydrogen dispensed was -147.2 gCO_{2e}/MJ. For the 59,212 miles of in-service Ocean Truck operation, the estimated overall emissions reductions were 15.5 kg NO_X (0.163 g/km), 1.01 kg SO_X (0.0106 g/km), and 304.8 metric tonnes of CO_{2e} (3.2 kg/km) compared to the diesel baseline vehicles including both tailpipe emissions and the emission from producing the fuel sources.

Section 1: Purpose and Approach

1.1 Project Purpose

The City of Los Angeles Harbor Department (Port of Los Angeles, POLA) partnered with the California Air Resources Board (CARB), Equilon Enterprises, LLC (d/b/a Shell Oil Products USA) (Shell), Kenworth Truck Company (Kenworth), Toyota Motor North America (Toyota), the Port of Hueneme (POH), United Parcel Service (UPS), Total Transportation Services, Inc. (TTSI), Southern Counties Express (SCE), Toyota Logistics Services (TLS), the National Renewable Energy Laboratory (NREL), and the South Coast Air Quality Management District (South Coast AQMD). The S2S project partners demonstrated a collaborative zero-emission goods movement project. For this demonstration, Kenworth developed 10 ZE Class 8 hydrogen FCEV trucks that integrated Toyota's fuel cell electrification technology. UPS, TTSI, SCE, and TLS operated the trucks throughout the Los Angeles basin, including the San Pedro Bay ports, and inland locations such as Riverside County. To create accessible fueling, Shell designed and constructed two renewable hydrogen fueling stations located in Ontario and Wilmington. Additionally, POH demonstrated two ZE yard tractors at their facility, with the infrastructure needed to support operation, and TLS demonstrated an additional two ZE forklifts to showcase a complete supply chain operating on zero emissions.

1.1.1 Project Goal

POLA partnered with world-leading original equipment manufacturers (OEMs) Kenworth, Shell, and Toyota to establish a new forward-looking ZE framework for future goods movement throughout Southern California and beyond. NREL led all data collection and analysis for the equipment and supporting infrastructure during the life of the project. The project provided critical regional hydrogen fueling infrastructure for short, medium, and especially long-haul drayage provided by 10 ZE hydrogen FCEV drayage trucks. The project showcased a complete ZE supply chain from the time that a ship arrives at POLA until cargo reaches its final storefront destination.

1.1.2 Project Objectives

Key project objectives are summarized below:

- Support the goals of CARB's Zero-and Near-Zero Emission Freight Facility Projects
- Support the POLA's Clean Air Action Plan (CAAP) goals
- Realize a bold and transformative ship/shore-to-store ZE transport vision to serve as a future template for ZE goods movement
- Design, develop, build, operate and support FCEVs for demonstration at port facilities and warehouses
- Design, develop, build, operate and support a heavy-duty hydrogen station network and associated market-enabling fueling protocols and standards demonstration
- Purchase and demonstrate POH's first ZE battery-electric yard tractors

- Demonstrate two ZE forklifts to showcase a terminal to drayage supply chain operating with zero emissions
- Collect and evaluate demonstration data, including performance metrics and costs

1.2 Project Approach

POLA assembled a strong team of advanced technology OEMs for this 12-month ZANZEFF demonstration project. This project built upon on existing technical demonstrations of ZE goods movement technologies by taking the next step toward implementation of a zero-emissions pathway for transporting goods from a marine container terminal to the final destination of the drayage portion of the container's trip. POLA's approach to team with OEMs for this project facilitated OEM experience with new ZE platforms to support the long-term viability of these designs as production equipment in the commercial market.

Specifically for this project, 10 hydrogen (H₂) fuel cell electric ZE Class 8 on-road trucks were designed and developed through a collaboration between Kenworth Truck Company and Toyota Motor North America to move cargo from the Port of Los Angeles to inland locations such as Riverside County and the Inland Empire.

Supporting this demonstration fleet was hydrogen fuel infrastructure developed by Shell to support the operation of the fuel cell electric trucks. Shell designed and built two new, large capacity hydrogen fueling stations in Wilmington and Ontario, California for this project. These two stations, in conjunction with two additional heavy-duty stations at Toyota facilities established a four-station strategically-developed, -situated, and -integrated hydrogen fueling network, that will continue to enable ZE freight transport to flow through the ports and across the greater Los Angeles basin, as the ZE truck fleet grows. The on-road trucks were operated by United Parcel Services, Toyota Logistics Services Total Transportation Services Inc., and Southern Counties Express.

The project also expanded and developed ZE off-road equipment, including the Port of Hueneme's first two electric yard tractors, and the expanded use of ZE forklifts at Toyota's port warehouse.

1.3 Activities Performed

1.3.1 Task 1 Project Administration

Project administration and management included tasks of fiscal administration; project monitoring; project scheduling; conducting weekly, monthly, and as-needed team meetings; preparing quarterly status reports; and final reporting. The task involved additional administrative support for project development, press and media events, informational documents, agency updates, and agency liaison. A project kick-off meeting was held on April 16, 2019, monthly project update meetings were regularly conducted, and quarterly reports were submitted on time throughout the project term.

Overall, the S2S project was managed as proposed in the grant application, though, due to the COVID-19 pandemic and the related State of California mandated Safer-At-Home orders, the

project encountered significant administrative, production, supply chain, and infrastructure delays. During the course of the project's term, staggered factory reopening and travel bans adversely impacted the project timeline. Travel was limited internationally, interstate, and regionally. At the Kenworth and Toyota facilities, the limitation of a single engineer in a test cell at a time, imposed during the height of the pandemic, also adversely impacted project implementation. Schedules for the Los Angeles Department of Water and Power (DWP) were heavily impacted in 2020 by unprecedented California wildfires alongside COVID-19 restrictions, resulting in delays to finalize power to the Shell station commissioning in Wilmington, CA. Further, COVID-19 restrictions resulted in appointment cancellations and scheduling delays at Shell's Ontario station build. Southern California Edison staff was diverted to wildfire prevention measures during Q3 2020, causing infrastructure delays at POH for their infrastructure project. Although some restrictions were lifted during Q2 and Q3 2021, late Q3 and Q4 registered spikes in COVID-19 cases, resulting in continued impacts to the project schedule. During 2022, the project continued to experience challenges related to scheduling, acquisition of raw materials, long lead-times, and personnel shortages.

Despite the COVID-19 related project delays, the S2S team went to great lengths in supporting project implementation. Through ingenuity and collaboration, the team progressed toward meeting milestone deliverables for 2021 and 2022. On May 12, 2021, the first Kenworth/Toyota Ocean truck began in-service operation. By November 1, 2021, all 10 Ocean trucks were in service. On July 1, 2021, the Shell Ontario fueling station was fully commissioned. The Shell Wilmington fueling station came online on July 14, 2022. Two Kalmar zero-emission yard tractors and supporting infrastructure began operating at POH on January 24, 2022. Construction for the 4160 service for the e-crane infrastructure at POH was completed November 26, 2022. The ZE forklifts operated successfully at the Toyota warehouse facility. NREL's data collection was conducted during the course of the demonstration with robust data sets across project metrics.

Overall, while there were significant delays due to circumstances beyond the project team's control, the project was ultimately completed in accordance with the project agreement and is considered to be a success, providing results that document excellent insight and progress in the statewide effort to transition to a ZE goods movement economy.

1.3.2 Task 2 Design, Construction, and Commissioning of Hydrogen Infrastructure

For this task, two new high-capacity hydrogen fueling stations were designed, constructed, and commissioned to serve heavy-duty fuel cell electric trucks in the region, including the project's Ocean fleet. One station is located in Ontario, with a second station located in Wilmington at a Shell industrial site.

The goal of this task was to finalize the engineering design, permitting, equipment procurement, installation, testing and commissioning of each of the project's hydrogen fueling stations located:

- Adjacent to Shell Lubricants Facility, 1901 E. Grant Street, Wilmington, CA 90744

- Travel Centers of America, 4325 E. Guasti Rd. Ontario, CA 91761

The Ontario station was commissioned on July 21, 2021, and the Wilmington station was commissioned on July 14, 2022.

A third station, funded by an earlier California Energy Commission (CEC) Hydrogen Freight project and applied as match share for the Shore to Store project, was available for hydrogen fueling. This station is located at:

- Toyota Logistics Services, Port of Long Beach, 785 Edison Ave., Long Beach, CA 90813, with entry to the Shell fueling station at 1631 Pier B St., Long Beach, CA 90802

Prior to station commissioning, the Toyota facility in Gardena accommodated the Ocean trucks with hydrogen fuel. The station is located at:

- Toyota Technical Center, 1630 186th St., Gardena, CA 90248

1.3.3 Task 3 Ocean Truck Fleet Design, Build, and Support

Kenworth and Toyota designed, built, and conducted the performance evaluation of 10 Class 8 fuel cell electric trucks that were demonstrated by the following partner fleets: UPS, TTSI, SCE and TLS. The National Renewable Energy Laboratory was responsible for data collection and analysis of demonstration fleet data, as well as hydrogen fuel station operating data. UPS, TTSI, SCE, and TLS operated the trucks throughout the Los Angeles basin, including the San Pedro Bay ports, inland locations such as Riverside County. The vehicles completed functional, track and local service tests to meet minimum reliability and performance standards prior to field deployment. Service and support were provided by the Kenworth/Toyota team during the demonstration period (see Figure 1).

Figure 1. Five Ocean Fleet FCEVs at the Shell Hydrogen Station



Photo Credit: Toyota Motor North America

1.3.4 Task 4 Yard Tractors and Charging Infrastructure

Under Task 4, the project team procured off-road ZE battery-electric equipment for the demonstration and installed associated charging infrastructure. Specifically, this task encompassed the following key activities:

- Procure two ZE yard tractors for operation at POH
- Installation of charging stations to support the above equipment
- Installation of charging infrastructure at POH to support three Liebherr 420 Hybrid-Electric Cranes
- Procure two ZE forklifts for operation at the TLS warehouse.

1.3.5 Task 5 Technology Demonstrations

For this project, a variety of technologies were demonstrated. The demonstrations included 10 prototype Class 8 hydrogen fuel cell electric trucks that were operated in revenue service by four fleet operators (UPS, TTSI, SCE and Toyota Transport) over a variety of drayage and regional routes across Southern California. Kenworth and Toyota supported the vehicles over the demonstration period with training, operational, and maintenance support.

The trucks were developed in two phases. Phase 1 included development and testing of the first five trucks, with the lessons learned being used to inform the second five trucks in Phase 2.

Task 5 also included demonstration of two battery-electric ZE yard tractors at POH, beginning on January 24, 2022. The demonstrated forklift at Toyota's Warehouse was evaluated April through November 2021.

1.3.6 Task 6 Data Collection and Analysis

Task 6 is a core function of the project: to collect operational data for a 12-month demonstration and use these data to assess the results and impacts of the technology demonstration. For this task, NREL developed an In-Use Data Collection Test Plan to guide data collection for baseline and advanced vehicles including 10 hydrogen fuel cell electric trucks, two electric yard tractors, and two electric forklifts, as well as two newly constructed hydrogen fuel stations. For this task, NREL:

- Supported data collection on the baseline and advanced vehicles
- Performed analysis and reporting on the collected vehicle, infrastructure, and maintenance data
- Used advanced data analytic methods to explore the data sets and provide additional insights
- Reported results on a quarterly basis
- Provided documentation of the data collection and analysis effort for inclusion in the final report.

Section 2: Design, Build and Construct

Below is a summary of the design, build and construction efforts to commission the project equipment and associated fueling infrastructure.

2.1 On-Road Trucks Demonstration

The ZANZEFF project demonstrated technology that facilitated operation of Class 8 trucks with zero tailpipe emissions, greater range when compared with pure battery-electric alternatives, lower gross vehicle weight rating (GVWR), and quick fuel times. Further development of this technology will enable a more practical option for zero-emission heavy transportation. Limited development of Class 8 fuel cell electric systems has been in process for several years. The key to this successful project was combining the existing Kenworth T680 chassis and high-voltage drivetrain, developed for other hybrid platforms, with Toyota's fuel cell system developed earlier for Mirai passenger vehicles.

For this project, Kenworth built 10 FCEVs in collaboration with Toyota. Kenworth internally refers to the program as Project Ocean. The trucks are named and numbered accordingly (Ocean 1, Ocean 2, etc.).

One of the primary project benefits was the creation of a fleet of 10 trucks. The fleet provided a platform to compare truck performance and create a testbed for future development and improvement. The project team of skilled designers, developers, engineers, and test technicians provided invaluable knowledge and cumulative experience in prototyping and debugging the trucks during development and commissioning. In addition, the project yielded a fundamental understanding of ZE systems within the Class 8 freight transportation context.

2.1.1 On-Road Vehicle Demonstration Overview

For the ZANZEFF FCEV project task, a total of 10 Class 8 hydrogen fuel cell electric trucks were demonstrated. These trucks were developed through the collaboration between Kenworth Truck Company and Toyota Motor North America to move cargo from the Los Angeles basin ports and on to inland locations such as Riverside County, and the Inland Empire.

The resulting Kenworth T680 fuel cell electric truck offers 420kW electric traction motor and a 300-mile range with a 15-minute refill time. Two of the 10 trucks (Ocean 3 and Ocean 4) became the first Class 8 zero-emissions fuel cell electric vehicles to drive to the 14,115-foot summit of Pikes Peak in Colorado. Both trucks bobtailed (without an attached trailer) and displayed superb power and exhibited excellent drivability over the 156 twisting turns and switchbacks during the 4,700-foot elevation gain to the summit. The trucks handily negotiated grades between 7 and 10 percent over the famous 12.42-mile Pikes Peak International Hill Climb course.

The vehicle assembly was undertaken at the Kenworth Factory, Renton, WA, where the trucks completed comprehensive testing that included safety, compliance, performance, and operator convenience evaluations over 40 consecutive hours of rapid mileage accumulation. Vehicle testing was carried out at the PACCAR Technical Center, located in Mount Vernon, WA. All 10 trucks were delivered to California for final inspections and handoff to customers for field trials. The target market for this truck design is regional and short-haul, pickup, and delivery applications. Figure 2 depicts one of the project trucks driving on the open road at sunset. Table 1 provides an overview of each project truck, the fleet demonstration partner, and the delivery, demonstration start, and completion dates.

Figure 2. Ocean Truck climbing the summit of Pikes Peak in Colorado



Photo Credit: Kenworth Truck Company

Table 1. Project Truck Fleet Operation Summary

Truck	Fleet Partner	Delivery Date	Start Date of Operation	End Date of Operation
Ocean 1	TLS	6/30/2021	7/7/2021	1/31/2022
Ocean 2	TLS	7/9/2021	7/15/2021	1/31/2022
Ocean 3	TLS	4/27/2021	6/8/2021	8/1/2022
Ocean 4	SCE	4/23/2021	5/12/2021	1/22/2022
Ocean 5	TLS	7/16/2021	7/23/2021	1/31/2022
Ocean 6	UPS	8/27/2021	10/29/2021	1/31/2022
Ocean 7	TTSI	9/8/2021	10/29/2021	1/31/2022
Ocean 8	TTSI	7/23/2021	10/29/2021	1/31/2022
Ocean 9	UPS	8/9/2021	10/29/2021	8/5/2022
Ocean 10	UPS	9/15/2021	10/29/2021	8/5/2022

Source Credit: Kenworth Truck Company

2.1.2 Fuel Cell Electric Truck Overview

A Fuel Cell Electric Truck generates its own electricity onboard from hydrogen, with water as the only emission. A fuel cell “stack” combines the stored hydrogen with oxygen from the ambient air, a chemical reaction that produces electric current, and water.

The Ocean trucks are equipped with two Toyota Gen 1 fuel cell stacks. Each fuel cell stack can generate 114 kW maximum at 650V. Battery voltage is converted to 650V via bidirectional converters. Recovered regenerative energy is stored in the 12-kWh lithium-ion batteries at 300V. The 650V voltage is then distributed to various high-voltage components through a high-voltage power distribution (HVPD) box. The high-voltage components include two electric traction motors; air compressor; heating, ventilation, and air-conditioning (HVAC) compressor; power steering pump; and 650V to 48V DC-DC converter. The dual Cascadia Motion HVH410-075P traction motors are capable of 420-kW peak power. Mechanical power is routed through the Eaton 4-speed automatic transmission into a standard tandem rear axle. The 650V to 48V DC-DC converter provides 48V power to the four coolant pumps and eight cooling fans. The pumps include a traction motor pump, two power electronics pumps, and a cab heat pump. The fans include two traction motor fans, two power electronics fans, and four front radiator fans. Figure 3 provides a detailed vehicle layout, including the location of various key components used on the Ocean truck.

Figure 3. Ocean Trucks Layout of Major Components

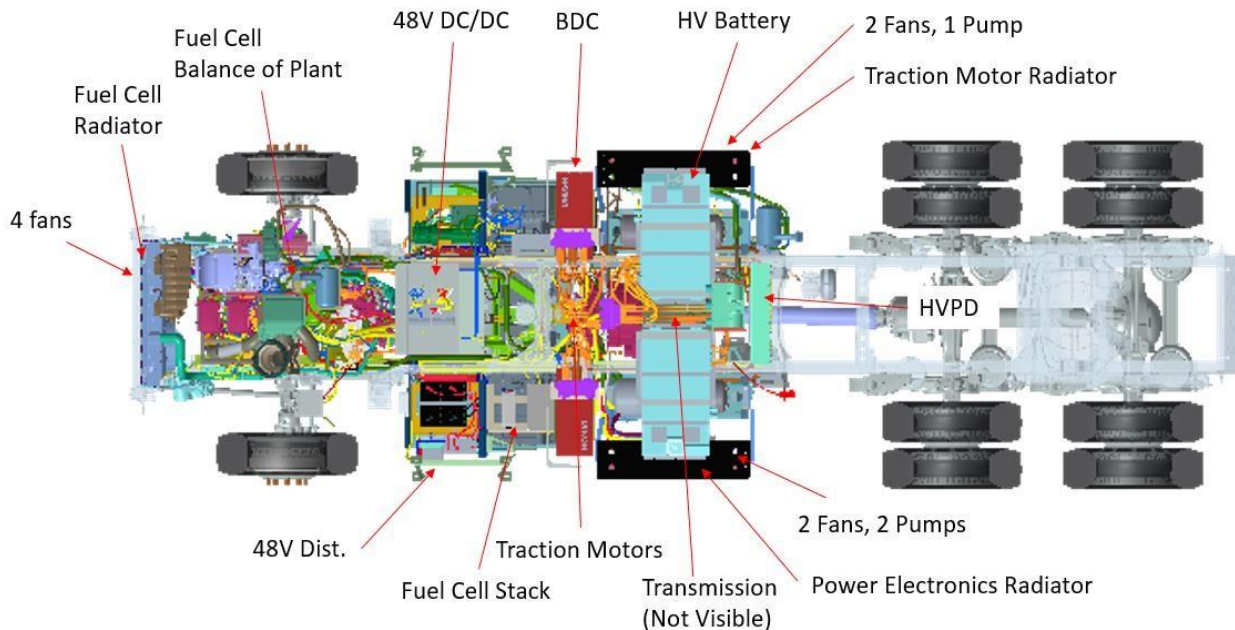

Photo Credit: Kenworth Truck Company

2.1.3 Technical Specifications

The dual rear axle T680 Day Cab was selected as the base model for this project. The 2.1-meter-wide cab is the most aerodynamic truck in Kenworth's 90-year history. This highly configurable model established a new standard of excellence since its production launch in 2013. The truck is available as a glider (without a drivetrain), with dual or single rear axles and in this configuration can be applied to a reasonably sized market. This chassis specification was also selected because it is well suited for pickup and delivery and regional-haul applications. The selection of the single-axle chassis and application resulted from a model-based design process and a detailed digital layout. Key technical specifications of the Ocean trucks are summarized below:

- Model is T680 FCEV
- Twin Toyota hydrogen fuel cells
- Weight is 20,500 pounds (lbs.) with 10,080 lbs. front and 10,420 lbs. rear
- Maximum gross vehicle weight rating (GVWR) is 80,000 lbs.
- Tire specification is Bridgestone R283A Ecopia 295/75R22.56
- Maximum speed is 65 miles per hour (mph)
- Hydrogen storage system 10,000 psi operating pressure
- Spun carbon fiber tanks, with capacity of 60 kilograms (kg) at 700 bar
- Traction motor is Cascadia Motion HV410-075P

- Eaton 4-speed heavy-duty electric vehicle automatic transmission
- 12 kilowatt-hour (kWh) lithium-ion batteries at 300 volt (V)
- Height is 13 feet, 7 inches
- Wheelbase is 216 inches.

Major subcomponents are discussed below.

2.1.3.1 Fuel Cell System

The fuel cell is composed of an anode, a cathode, and an electrolyte membrane. Hydrogen is passed through the anode, and oxygen through the cathode. The hydrogen molecules are split into electrons and protons. As protons pass through the electrolyte membrane, electrons pass through a circuit, generating an electric current. At the cathode, the protons, electrons, and oxygen combine to produce water molecules, which drips from a hidden vent pipe beneath the vehicle. There are no other byproducts. The excess electricity generated by the fuel cell and by regenerative braking is stored in a lithium-ion battery. The Toyota system uses two Toyota Gen 1 Mirai fuel cell stacks. Each fuel cell stack can generate 114 kW maximum at 650 V. Figure 4 depicts the fuel cell layout.

Figure 4. Fuel Cell Layout

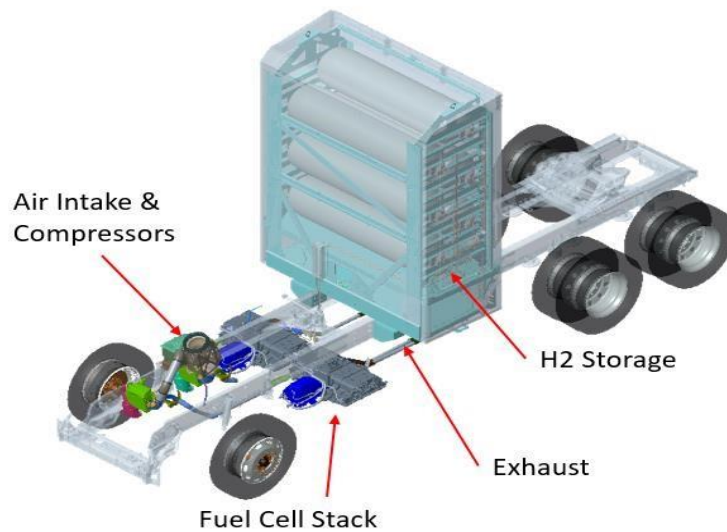

Photo Credit: Kenworth Truck Company

To provide sufficient power for the demands of heavy-duty trucks, the Toyota team integrated Toyota’s class-leading fuel cell technology and a high-voltage battery optimized around providing optimal fuel cell performance. The resulting systems are described below:

Dual Fuel Cell Module – The system consists of two fuel cells, each with its own boost converter integrated into a frame, mounted between the frame rails of the truck beneath the cabin. Figure 5 depicts the dual fuel cell assembly.

Figure 5. Dual Fuel Cell Assembly



Source Credit: Toyota Motor North America

Power Control Unit (PCU) Assembly – To manage and optimize the power split and balance between the Toyota fuel cells and the high-voltage battery assembly, Toyota power control units were utilized. These were packaged within the engine bay of the truck. Figure 6 depicts the dual PCU assembly.

Figure 6. Dual PCU Assembly



Source Credit: Toyota Motor North America

High-Voltage Battery Assembly – Two high-voltage batteries were integrated into the hydrogen storage cabinet to minimize the overall vehicle length. These batteries are used to

supplement the fuel cells during high power events and for regenerative braking. Figure 7 depicts the high-voltage battery assembly, and Figure 8 is a photo of the high-voltage battery integrated into the hydrogen storage cabinet.

Figure 7. High-Voltage Battery Assembly



Source Credit: Toyota Motor North America and Toshiba

Figure 8. High-Voltage Battery Integrated into Hydrogen Storage Cabinet



Source Credit: Toyota Motor North America and Toshiba

2.1.3.2 Eaton High-Voltage Power Distribution Box

The Eaton HVPD box manages and distributes all the high-voltage power to the high-voltage accessories. The HVPD is controlled by the vehicle supervisory controller via Controller Area Network (CAN) communication. The HVPD performed reliably at 650 volts required for this truck. Additional modifications were required to accommodate all high-voltage accessories;

these are discussed in Section 2.1.4.2 Electrical improvements. Figure 9 depicts the Eaton HVPD box.

Figure 9. Eaton HVPD Box



Photo Credit: Kenworth Truck Company and Eaton Corporation

2.1.3.3 PD400 Motor Inverters

The John Deere Electronic Systems (JDES) Inverter Family is a series of power inverters designed to provide advanced control for alternating current (AC) motor applications. The inverters convert high-voltage direct current (DC) power to three-phase AC power to drive various components in a compact, rugged, environmentally sealed package. The JDES series is built upon a common hardware platform accommodating a wide range of possible inverter schemes with standard, configurable software modules that determine specific family members. The JDES series inverters are designed for use in a variety of applications, including for use on an electrified vehicle as an engine assist to reduce peak electrical demand under high dynamic load conditions and provide brake energy recapture, which increases overall vehicle efficiency. There are two PD400 single inverters which run each of the electric traction motors. Figure 10 depicts the JDES PG 400 single inverters used for this project.

Figure 10. JDES PD400 Single Inverters

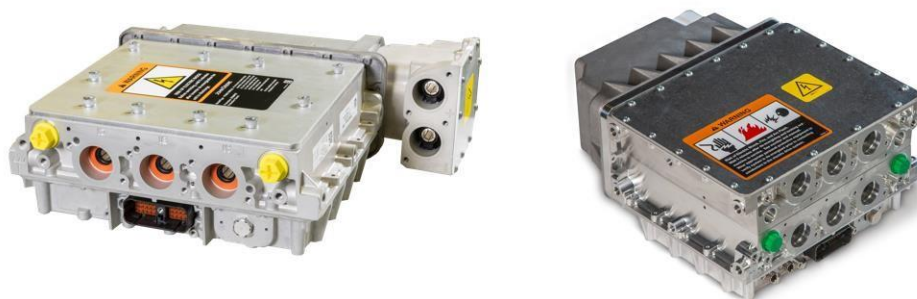

Photo Credit: Kenworth Truck Company and John Deere

2.1.3.4 Eaton Transmission

The Eaton Fuller 4-speed auxiliary transmission, depicted in Figure 11, was designed for applications requiring high reduction and heavy truck applications. The transmission is mechanically coupled to the dual Cascadia Motion motors and directly drives the rear axles via a mechanical drive shaft. The automated manual transmission prototype is controller area network (CAN) capable and driven through the transmission control unit, which communicates the desired motor torque, output speed, and gear selected. Four-speed transmission:

- 1st: 5.78:1.0 gear ratio
- 2nd: 3.25:1.0 gear ratio
- 3rd: 1.8:1.0 gear ratio
- 4th: 1.0:1.0 gear ratio

Figure 11. Eaton 4-Speed Transmission

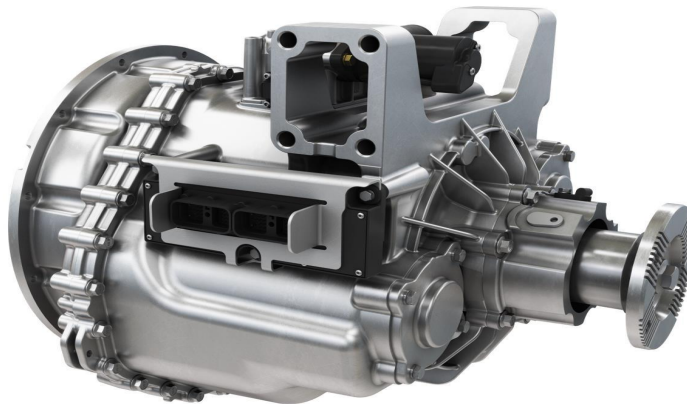

Photo Credit: Kenworth Truck Company and Eaton Corporation

2.1.3.5 Cascadia Motion Drive Motors

Cascadia Motion supplied the HVH410-75P motors for heavy-duty hybrid applications. The motors used in Ocean trucks have a power output of 420 kW peak power (See Figure 12).

Figure 12. Inline Dual Cascadia Motion Motors

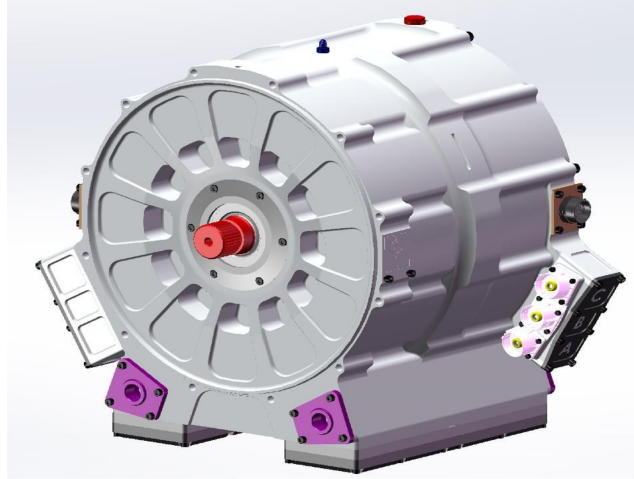

Photo Credit: Kenworth Truck Company and Cascadia Motion

2.1.3.6 48V DC-DC Converter

The 48V converter steps down the 650V high-voltage output from the fuel cells to 48V to power the auxiliary systems on the trucks (i.e., pumps and cooling fans), which all operate at 48V. The converter helps keep the voltage range between 42V and 54V. The default current rating is 268 amperes (See Figure 13).

Figure 13. Bel Power DC-DC Converter



Photo Credit: Kenworth Truck Company and Bel Power Solutions

2.1.3.7 Cooling System

The Ocean truck design includes four different cooling loops with individual functionalities:

Fuel Cell Cooling Loop – The fuel cell is cooled by the four front EMP (EMP is the manufacturer) fans and the front radiator. Based on the cooling requirement, the Toyota controller provides the cooling request to the Kenworth supervisory controller to control these fans. The speed of each fan can be controlled independently. This cooling loop utilizes a Kenworth T680 Radiator, four 15-inch 48V fans and Toyota coolant pumps.

Power Electronics Loop – This loop is comprised of a radiator with two EMP fans linked on the driver side. The speed of each fan can be controlled independently. The loop is responsible for cooling the auxiliary motors, 48V DC-DC converter, two PD400 inverters, and multiple fuel cell components. This cooling loop utilizes a custom radiator, two 15-inch 48V fans and two coolant pumps.

Traction Motor and Transmission Cooling Loop – The loop is comprised of a radiator with two linked EMP fans on the passenger side. The speed of each fan can be controlled independently. The loop is responsible for cooling the AC traction motor and transmission, as well as the condenser for the air-conditioning system, which cools the batteries and cabin. This cooling loop utilizes a custom radiator, a custom condenser, two 15-inch 48V fans and one coolant pump.

Cab Heat Cooling Loop – Ocean trucks have a separate coolant loop to provide cab heat to the cab interior. The cabin heater loop circulates coolant through a standard Kenworth T680 cab heater core using a 48V cab heat pump and Toyota Mirai high-voltage heater. Various cab heat settings are available through the driver display.

2.1.3.8 Ocean CAN Architecture

Figure 14 provides an overview of CAN architecture. Four additional CAN buses are added onto the bare gliders used to build the Ocean trucks. These additional CAN buses communicate at two different baud rates. Ocean trucks are equipped with a supervisory hybrid controller that manages the overall vehicle functions, including power distribution, torque control, and accessory operation. The V-CAN bus comes with the glider, and it is connected to the hybrid controller, hybrid display, and data logger.

Figure 14. CAN Architecture

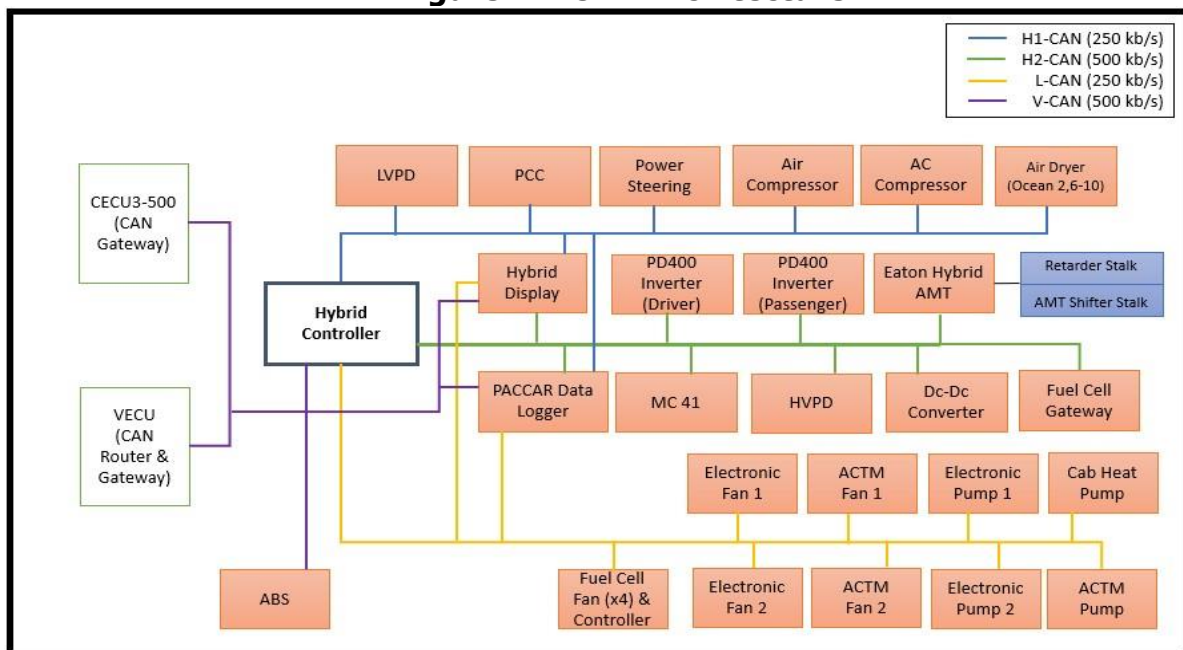

Source: Kenworth Truck Company

2.1.4 FCEV Equipment Commissioning Improvements and Lessons Learned

In the initial phase of the project (i.e., the first five trucks), the teams faced many challenges. Opportunities for improvements were discovered and implemented for improved truck function, with the most significant lesson learned being the immaturity/prototype nature of high-voltage components available at the time the trucks were built, especially for commercial vehicle applications. Multiple components either did not function on arrival from the suppliers, could not handle the requirements that were placed on them in a commercial vehicle setting, or failed due to fatigue. Experience from this project reinforced the need for significant collaboration with suppliers, and that investments are needed before commercial vehicle OEMs gain access to high-quality durable components. It is possible to assemble research and development vehicles with off-the-shelf components. However, they cannot be used to make optimized, heavy-duty production commercial vehicles. Key improvements made for Kenworth FCEVs are discussed below.

2.1.4.1 Mechanical Improvements

Below is a summary of the mechanical improvements implemented during the development of the 10 project trucks:

- The coolant architecture and installation of coolant pumps was revised for pump installation angle and bleed valve installation at pumps and radiators to address the deaeration challenge for the initial builds (i.e., phase one demonstration units).
- HVPD brackets were redesigned to improve serviceability.
- Worked with transmission supplier to change from bolts to studs to improve assembly.
- Revised 12V and 48V distribution boxes to improve manufacturing.
- Added unique trailer harness for Toyota Logistics Services.
- Packaging and mounting of opto-isolators, electronic components that use light to transfer signals between two isolated circuits, were added to reduce CAN communication errors.
- Packaging and mounting of battery chargers to compensate for the large current draw after the truck has shut down in order to upload data.
- Worked with the supplier to further seal the battery cabinet and prevent water intrusion.
- Worked with the supplier to relocate a hydrogen sensor to simplify maintenance checks.
- Improved mounting of the hybrid display.

2.1.4.2 Electrical Improvements

Below is a summary of the electrical improvements implemented during the development of the 10 project trucks:

- Due to multiple issues discovered during the assembly of the first five trucks (i.e., CAN bus physical layer issues, controller programming and calibration issues, low-voltage

and high-voltage wiring) multiple harnesses had to undergo significant revisions, including last-minute design changes. The team also built additional breakouts and programming harnesses as needed, in order to support multiple truck builds in parallel.

- Significant changes were made to the CAN architecture and vehicle wiring to allow the connection of all the CAN buses to the driver (hybrid) display.
- The HVPD box circuitry, on all 10 trucks, was reworked to assure reliable operation of the vehicles.
- A robust high-voltage interlock (HVIL) system was designed to protect the users and service personnel from unintended high-voltage exposure. Figure 15 outlines the high-level workings of the system. If this circuit is broken, the vehicle immediately shuts down the high voltage and will not allow the user to turn it back on until the circuit has been closed again.

Figure 15. High-Voltage Interlock System Design

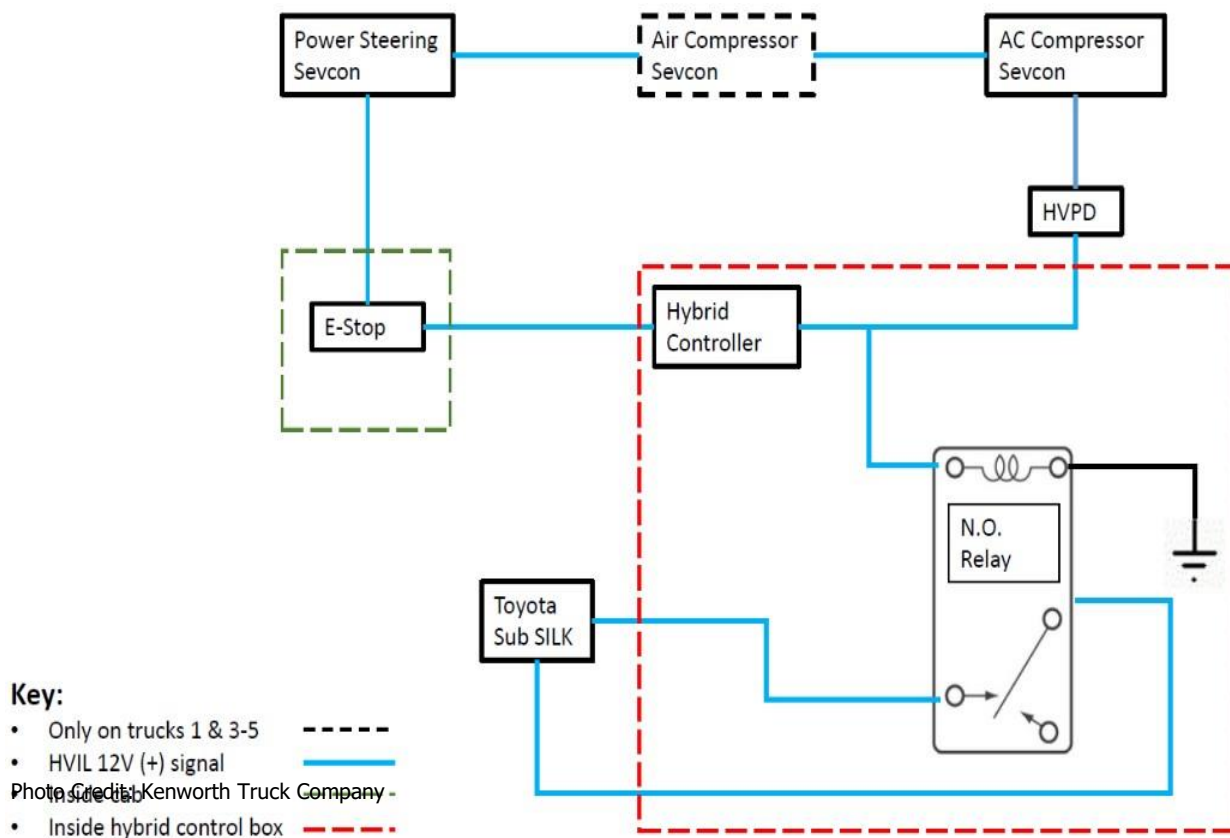

Source: Kenworth Truck Company

2.1.4.3 Controls Improvements

Early in the project, the team realized that the user needed a display to indicate key vehicle operation, diagnostic, and performance metrics. It was quite challenging to diagnose errors and root cause of shutdowns during the initial truck builds, as traditional diagnostic tools could

not be used for these prototype FCEVs. The team invested a significant amount of effort and resources to design, develop, test, and validate a driver display. The improved display provides key information for the driver to operate the truck, performance metrics, diagnostics information, and the ability to report breakdowns. Over 1,200 operating parameters are continuously monitored and logged on the Ocean trucks. Figure 16 provides a photo of the main screen of the display, also referred as the hybrid display. Some of the key display features are listed below:

- Main screen provides truck operation information, performance, and faults to drivers.
- Advanced Engineering screen allows engineers and technicians to debug and diagnose component level issues, conduct advanced calibration, and view software revision information.
- Safety and critical items are automatically detected and shown with the appropriate indicator lamp.
- Drivers are able to report truck breakdown via the display.
- Software revision information was added for various components.
- Allows operator to command cabin heater requests (Low, Medium, High).

Figure 16. Hybrid Display

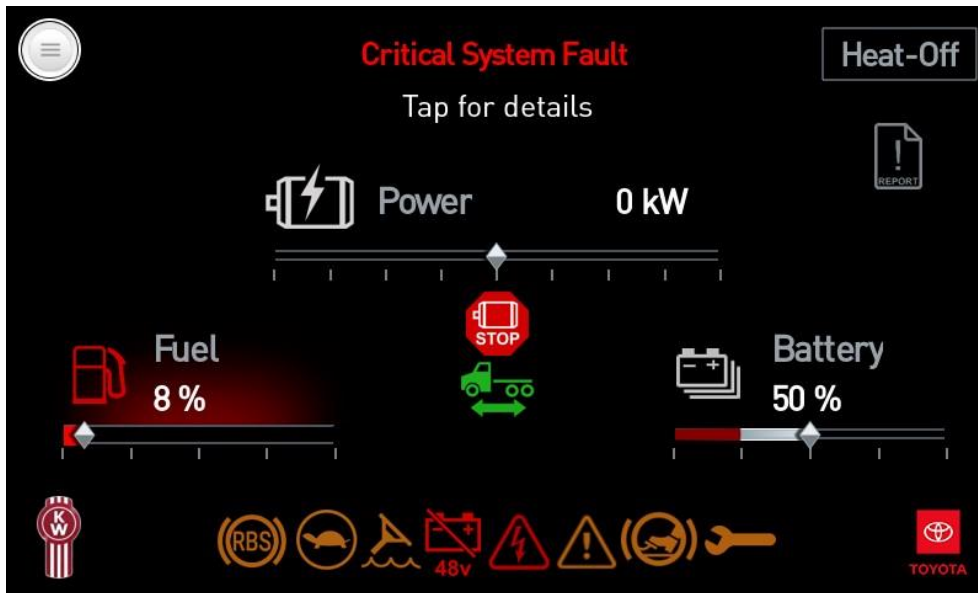

Photo Credit: Kenworth Truck Company

- While commissioning the initial trucks, there were few software-related shutdowns due to incorrect proportional integral derivative (PID) controller settings. Updates were made to the motor inverter calibrations to reduce the software-related shutdowns on the power steering, air compressor, and the HVAC compressor.

- During the initial drive testing, drivers reported inconsistent steering behavior ranging from stiff to slack steering response. Through consultations with subject matter experts at the PACCAR Technical Center, the issue was isolated to improper calibration of the power steering motor inverter operating characteristics. The improper calibration was rectified through multiple iterations of testing and calibration.
- During initial test drives, the transmission exhibited rough and slow shifting, which severely impacted the driving performance. The team worked closely with the transmission supplier to identify the root cause of these issues and improve the shifting and drive performance. Numerous iterations of testing and validation were performed to ensure correct behavior.
- During the initial test runs, the cooling fans ran at very high speeds resulting in unacceptable noise during idle and operator inconvenience. The cooling controls strategy was improved to adjust the output speeds while meeting the cooling requirements.

2.1.4.4 Other Improvements

- Air Compressor – Halfway through the project, the air compressor manufacturer discontinued the air compressor which the Kenworth team had initially integrated into the vehicle. The Ocean team worked closely with the supplier to integrate an intelligent air dryer and high-voltage eCompressor into six of the 10 vehicles. Ocean 2, Ocean 6-10 use a Bendix Air compressor.
- Data Logger – The Ocean team worked with other PACCAR teams to design, build, and implement a data logging system. The initial model of the data loggers procured for the program had significant issues related to data collection and uploads. So, the team worked tirelessly with the vendor to identify and procure an alternative data logger, including setting up an IT infrastructure to handle the massive volume of data. The improved system uploads vehicle performance and diagnostics data to the PACCAR servers in near-real-time. Additional changes were made to this system later in the project to allow Toyota to upload their data to their cloud through PACCAR equipment.
- A/C System Redesign – The original A/C system designed for Ocean trucks was inadequate and had frequent issues. The system underwent several changes to improve operation and efficiency. Kenworth worked with the external company, Red Dot, to redesign the A/C system to make significant mechanical, electrical, and controls updates to the system. Validation was completed at Red Dot's environmental chamber.
- 650V to 48V DC-DC Convertor – Halfway through the project, significant issues were detected with the 48V power system, some of which led to the potential damage of several of the 650V to 48V DC/DC converters. In order to mitigate component damage and improve user ease-of use, several changes had to be made to the 48V wiring and battery management system.

2.1.4.5 Key Takeaways

Throughout the simulation, early development, and deployment process, many takeaways led to current product improvements and efficiencies, including:

- OEM controls and electronics collaboration is as, or more, important than hardware integration.
- OEM and component supplier support is optimized when localized engineers are provided.
- Real-time data acquisition, sharing, collaboration, and analysis ensures that efficient counter-measure steps can be made in real-time.
- Early collaboration between OEMs and ZE powertrain suppliers helps both parties learn the challenges of enabling technology from each other's point of view.
- These and other learnings are integrated into the next generation of heavy-duty fuel cell electric offerings at Toyota using the next-generation (Generation 2) fuel cell system, as evidenced by the recently released Gamma truck.

2.1.5 Simulation Model and Vehicle Performance Forecast

2.1.5.1 Simulation Model

A significant amount of simulation work was conducted to define the performance expectations of the Ocean hydrogen fuel cell electric trucks for the ZANZEFF project. This work investigates how the fuel cell powertrain would perform within target duty cycles. The key output of the model is how the thermal system would respond and impact vehicle performance at the upper boundary condition. The simulation work also highlights the intended use cases and scope of the vehicle operation. The intended usage for these vehicles was in the drayage application focused around successfully delivering freight from the port to delivery sites located near the port. This usage represented a significant portion of POLA traffic and was thus the target scope for these vehicles. The simulation results showed that the vehicle would meet the intended usage criteria. Figure 17 shows a snapshot of the simulation model.

**Figure 17. Snapshot of Simulation Model
Vehicle Model**

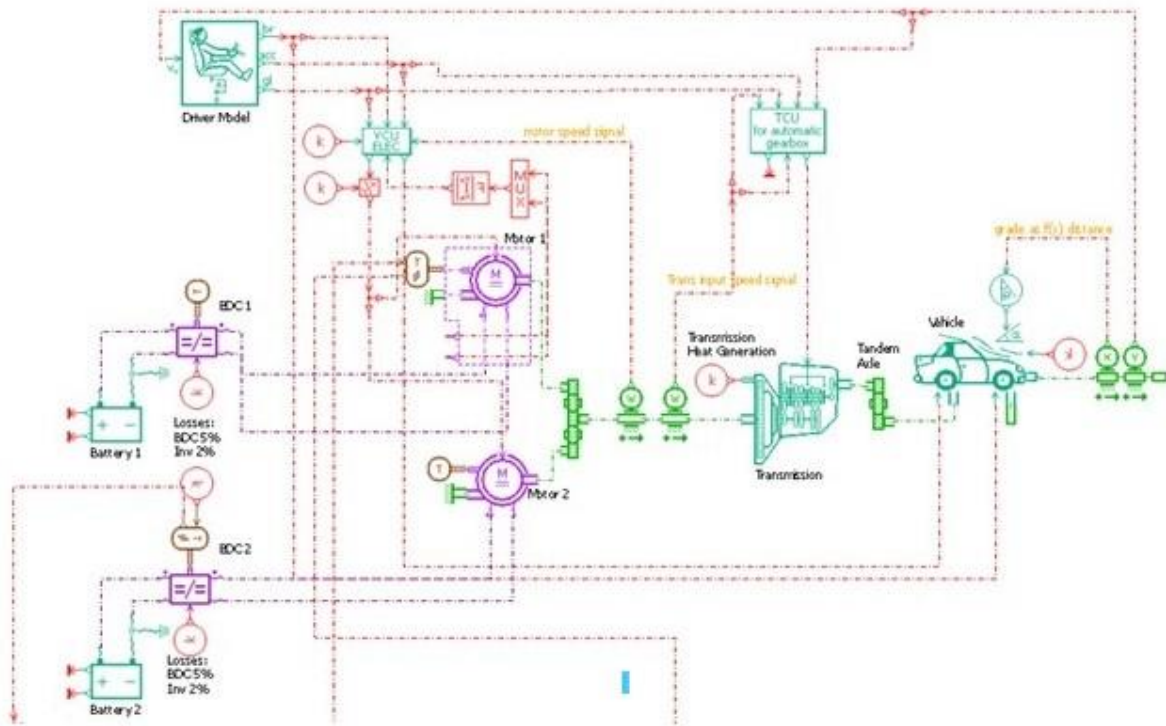

Power Electronics Cooling System Model

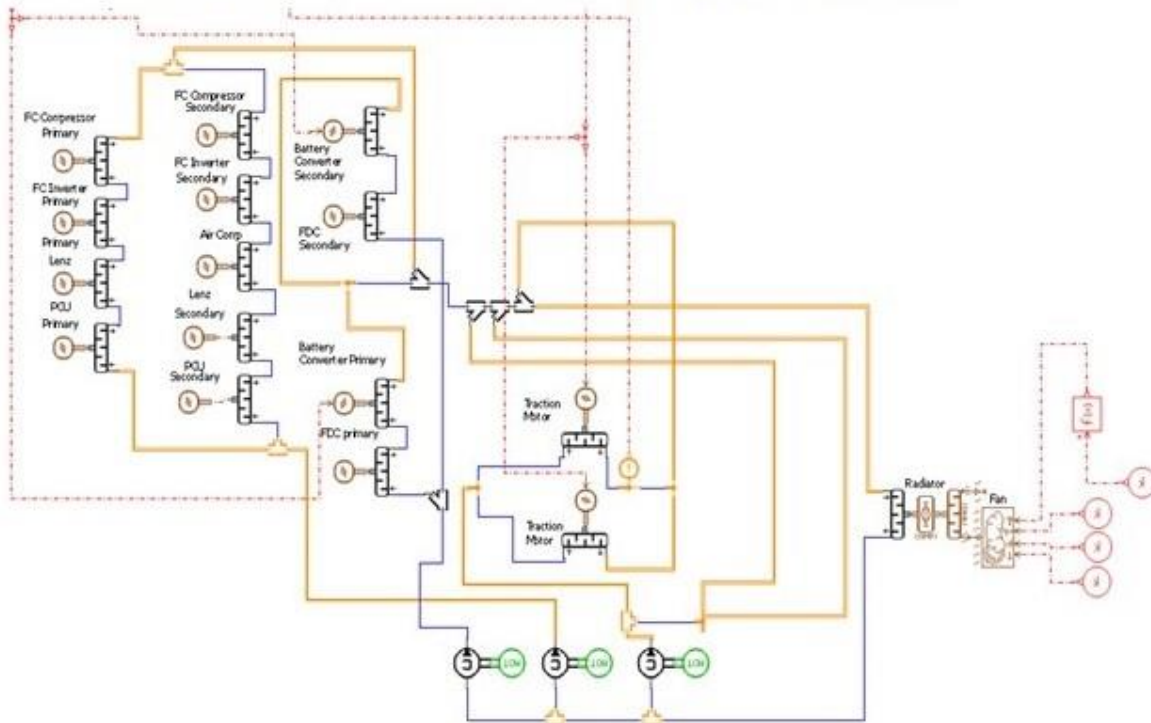

Source Credit: Toyota Motor North America

2.1.5.2 Vehicle Performance Forecast

The results of the model show that the vehicle performance falls within expected bounds. The yellow area indicated as 1a and 1b in Figure 18 represent the intended operating area for the ZANZEFF Fuel Cell Electric Trucks developed by Kenworth and Toyota. Area 2, the larger area indicated by a green boundary represents the targeted operational capability of the near-term production solution.

Figure 18. Intended Operating Area



Source Credit: Toyota Motor North America

2.1.6 Testing and Validation

2.1.6.1 Track Testing and Validation

The Kenworth Toyota project team produced a hydrogen fuel cell electric powered truck design that operates on hydrogen and recovered battery power that performs similarly to a standard Class 8 diesel truck. At the completion of the field trials, the fleet of 10 units accumulated nearly 60,000 of miles during testing and field test operation, including real-world demonstration testing by customers in the Los Angeles area.

The Ocean trucks successfully completed numerous tests regarding safety, compliance, operator convenience, and satisfied minimum reliability targets. The tests were performed at PACCAR Technical Center (Figure 19) located in Mount Vernon, WA. The PACCAR Technical Center is a world-class facility sited on 242 semi-wooded acres. The facility includes a 1.6-mile high-speed track and a 1.5-mile durability course.

Figure 19. Ocean Truck at PACCAR Technical Center



Photo Credit: Kenworth Truck Company

Figure 19 shows an Ocean truck running the rapid mileage accumulation test on the test track. Some of the evaluation tests performed are listed below:

- Basic vehicle drivability, maneuverability
- Torque limiting actions and effects
- Effects of supervisory controller disconnected
- Truck behavior when Anti-Lock Braking System (ABS), Right Hand Stalk (RHS), traction motors, and transmission disconnected
- Consequences of invalid key switch, parking brake, accelerator pedal input, and brake pressure switch
- Driver display operation and interaction

2.1.6.2 Pikes Peak Summit

In the second half of 2020, Ocean 3 and Ocean 4 became the first Class 8 zero-emission vehicles to drive to the 14,115-foot summit of Pikes Peak in Colorado. Both vehicles exhibited excellent drivability over the 156 twisting turns and switchbacks during the 4,700-foot elevation gain to the summit. The trucks handily negotiated grades between 7 and 10 percent over the famous 12.42-mile Pikes Peak International Hill Climb course. Figure 20 depicts a picture of Ocean truck taken at Pikes peak.

Figure 20. Ocean Truck at Pikes Peak

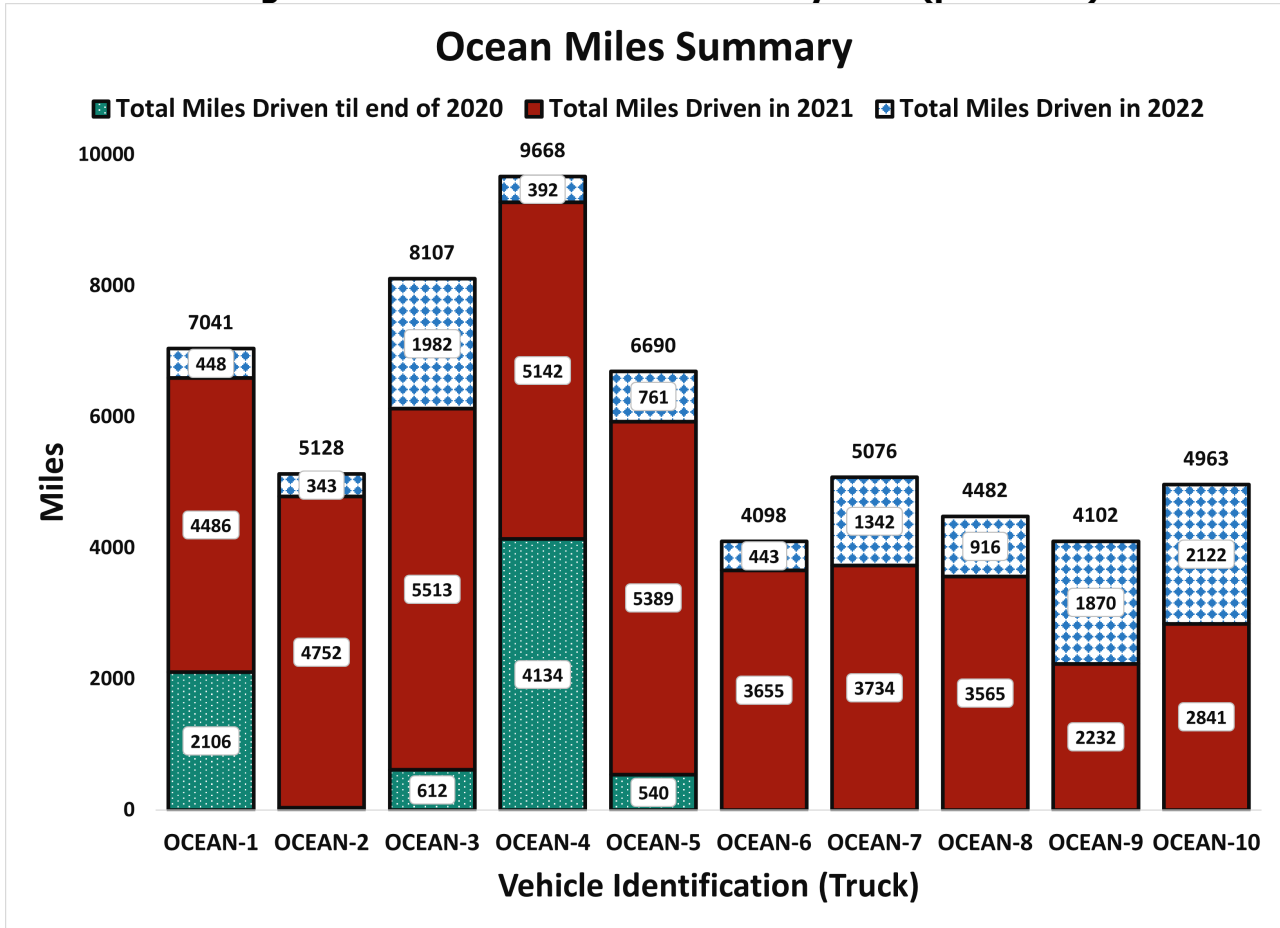

Photo Credit: Kenworth Truck Company

2.1.6.3 Mileage Metrics

Figures 21 and 22 provide the total miles driven, 59,212 miles by the entire Ocean fleet by year. The Ocean trucks assembled early in 2020 accumulated significant mileage compared to the Ocean trucks built later in the program. It also shows a breakdown of mileage accumulated per year as a percentage of total miles of all 10 trucks in addition to total fleet mileage. As the trend shows, more than 69% of the mileage was accumulated in the year 2021 when all 10 trucks were in service or being tested thoroughly on test tracks.

Figure 21. Fleet Distance Traveled by Year (per Truck)



Source: Kenworth Truck Company

Figure 22. Fleet Distance Traveled by Year (all trucks)

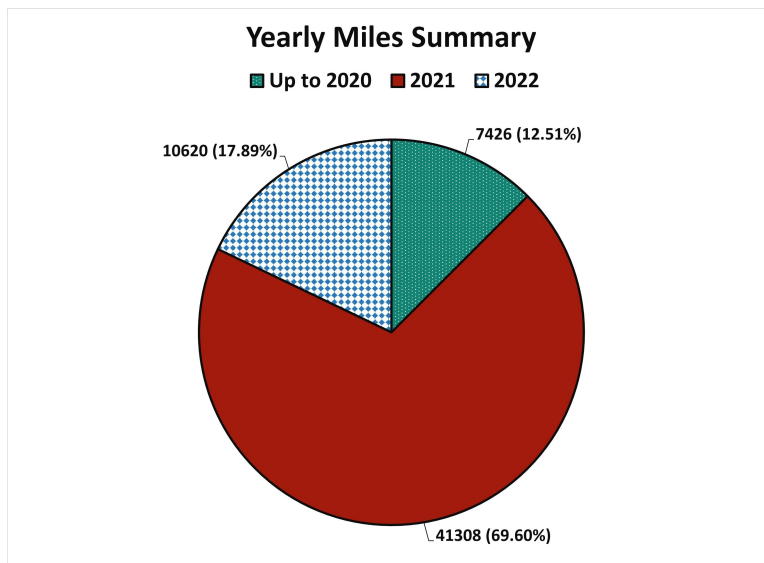

Source: Kenworth Truck Company

2.2 Hydrogen Infrastructure

For this project, foundational infrastructure was designed and commissioned by Shell to support the operation of the zero-emission Ocean truck fleet. Shell retained Fiedler Group (FG) to prepare documents required for design, permitting, bid solicitation and construction services. FG implemented a phased approach to accomplish the preparation of the documents, exhibits, and attain a permit ready to issue (RTI) status. The general contractor construction contract for both Ontario and Wilmington was awarded to Fastech.

Two large-scale hydrogen stations were constructed for this project in Ontario and Wilmington, complemented by the Shell station at the Port of Long Beach (i.e., Portal Station) that provided match share for S2S. This project also leveraged a smaller station that was not funded or supported by this project but provided an important linkage in the hydrogen fuel station network. These stations are located as follows:

- Adjacent to Shell Lubricants Facility, 1901 E. Grant Street, Wilmington, CA 90744
- Travel Centers of America, 4325 E. Guasti Rd. Ontario, CA 91761
- Toyota Logistics Services, Port of Long Beach, 785 Edison Ave., Long Beach, CA 90813, with entry to the Shell fueling station at 1631 Pier B St., Long Beach, CA 90802
- Toyota Technical Center, 1630 186th St., Gardena, CA 90248

The goal of this task was to finalize the engineering design, permitting, equipment procurement, construction, installation, testing, and commissioning of each of the project's hydrogen fueling stations.

2.2.1 Renewable Hydrogen and Environmental Impact

2.2.1.1 Carbon Intensity Value

Shell established an LCFS Tier 2 joint pathway, which is a dairy and swine manure renewable natural gas to hydrogen pathway via "book and claim" accounting. The pathway was established in April 2022 and is consistent with the Lookup Table Compressed Hydrogen pathway produced in California from central steam methane reforming of biomethane with two notable exceptions: the gaseous hydrogen transportation distance is lower than the default 100 miles distribution distance modeled in the Lookup Table pathway carbon intensity (CI), and the feedstock for hydrogen production was matched to biomethane attributes derived from dairy and swine manure digester gas. The lifecycle carbon intensity of the hydrogen dispensed is -147.2 gCO₂e/MJ.

2.2.2 Ontario Station

Shell broke ground at the Ontario site in Q4 2019. The Shell team installed camera feeds with real-time monitors. Construction proceeded at a robust pace throughout Q1 2020. The civil foundation work was completed, two compression stations and three dispensers were set, trenching for the new electrical conduit was finished, and the underground hydrogen piping was installed.

Beginning Q2 2020, due to COVID-19, all work was conducted using appropriate PPE, hygienic practices, and safe distancing techniques. Temperatures were taken when entering and leaving the site. The project experienced some equipment delays, due to supply chain issues, but the team successfully worked through the challenges.

By April 2020, the team completed installation of two compressors, two vent stacks above ground, and three dispensers. All materials were received and set. All underground mechanical and piping was installed. The site required electrical upgrades, which entailed installation of a new transformer. The two-phase switchover took place—Shell's liquefied natural gas (LNG) tanks were transferred to a new service, then 10 days later, they moved from C-Store to hydrogen. The system was powered in early May.

In May 2020, the refueling station moved from construction to the substantially complete phase. All of the equipment was received and set. The utility power service was complete and energized. The mechanical walkthrough took place in May and the resulting action items were completed in about 3 weeks, prior to entering the commissioning phase.

By June 2020, the station was deemed mechanically complete. The site was turned over from the general contractor to the equipment manager, Nel Hydrogen (Nel). Pre-commissioning activities began to confirm proper equipment installation and continuity: to open up equipment, start I/O (input/output) checks, continuity checks, and bumping motors. The pre-startup safety review took place on June 16 with the HSSE manager on-site, equipment manager, engineering consultant, and general contractor to review the site prior to introduction of hydrogen. The group reviewed not only the physical site, but also documentation, to ensure everything was in order and the safety systems performed as intended. The review was completed with a list of action items that were expected to be completed in about 2 weeks. Introduction of hydrogen was estimated for the week of July 7, 2020. However, toward the end of Q2 2020, some minor hardware changes were implemented, postponing introduction of hydrogen until August.

By October 2020, the station was mechanically complete, through the pre-startup safety review, had power to the site, and was ongoing commissioning activities. The system had been evacuated of nitrogen, was filled with a second trailer delivery of hydrogen, and was circulating hydrogen to the dispenser.

In November 2020, the system was circulating hydrogen, and it was circulating precooling gas to the dispenser. Three purity samples were taken and analyzed; one sample came back with residual grease. The nozzles were cleaned, and fresh samples were sent for analysis. Figure 23 provides an aerial view of the Ontario station during construction.

Figure 23. Aerial Photo of the Ontario Station Construction



Photo Source: Shell (aerial drone)

By December 2020, the station was circulating hydrogen within the equipment, the ground storage, and through to the dispensers. The sequenced plan was to fuel light duty vehicles first, to facilitate flow through the dispensers and confirm the system functionality. The station completed five light duty fills in December. The next step in the sequence was to bring in a 350 bar UPS truck, which was scheduled earlier in the month, but cancelled, due to COVID-19 restrictions. The UPS truck was rescheduled for December 21. The initial fill was accomplished, but midstream a software glitch opened vent piping to the H70 system, lifting the relief valve midstream. The fill was attempted again, but with the same result. The issues were reviewed, and the fill was rescheduled. The fueling protocol was reprogrammed and the truck successfully filled on January 8, 2021. The hydrogen dispenser meter certification for the Department of Food and Agriculture, Division of Measurement Standards (DMS) was scheduled for December, but was cancelled, due to COVID-19 restrictions. The CARB Hydrogen Station Equipment Performance (HyStEP) testing was also cancelled. Although challenges were encountered scheduling the DMS, the two H70 meter certifications were completed on January 18, 2021. The third DMS meter calibration for the Class 6 truck H35 dispenser was completed in April 2021.

During Q4 2020 and into Q1 2021, additional COVID-19 restrictions resulted in appointment cancellations and scheduling delays at Shell's Ontario station build, which included the 350 bar (H35) fill, DMS meter measurement, and the CARB HyStEP device.

In February 2021, a glitch was found in the testing protocol between Nel, the equipment supplier, and Toyota. The Toyota Tundra hydrogen dispenser testing apparatus (HDTA) was substituted for the CARB HyStEP device, which was unavailable for scheduling over the next year. Normally, the HyStEP device is utilized for the test matrix of the safety systems and performs a fueling test to certify the station. Toyota planned to use the HDTA to test certain safety systems and fueling protocol to enable fueling of the Ocean trucks and the Beta truck (a

Toyota R&D prototype Fuel Cell Electric Class 8 Kenworth Truck). The glitch was resolved and the HDTA test took place on February 25, 2021. Some of the tests were completed, but others failed. During testing, there was an issue with the variable speed drive on the station compressor. When switched to the other compressor, there was a priming loop and lock-up issue. The test was terminated and rescheduled for March 25. Both issues were determined to be programming related and further internal testing proved successful. Unexpectedly, the HyStEP device became available and was scheduled for April 12, 2021. The fault test matrix was completed, and the report was issued to Shell, Nel, and Toyota for review and discussion.

By mid-June 2021, the Ontario station was ready for test fueling of the Beta and Ocean trucks. The fueling protocol and back-to-back fill performance tests were completed on July 15, 2021. With two nozzles connected to two 30-kilogram compressed hydrogen storage systems, the systems completed a 23-kilogram fill from 15% state of charge up to a 96% state of charge. As of July 21, the Ontario station was open and supporting the Ocean fleet between 6:00am – 3:00pm, with support from the equipment provider, Nel. Figure 24 provides a view of the completed Ontario station.

Figure 24. Photo of the Ontario Station



Photo Source: Shell

In August 2021, the Ontario station began having issues with the compressor module, causing the station to operate at 50% capacity. With one of the two dispensers operational, the fill was taking twice as long, filling in sequence rather than in parallel. The issue involved an underperforming oil injection pump, causing the system to trip offline. In September 2021, the station was experiencing mixed performance and was offline for several days. The issue with the oil injection pump was still being repaired. The second compressor module required repair of a faulty rod fuel bearing, which is part of the internal structure of the compressor. With both compressors down, the station was temporarily offline. The Ontario station was partially repaired and back online at 50% capacity in October 2021.

During Q4 2021, the station continued to operate on one compressor module with some intermittent periods offline. Supply chain issues and personnel staffing challenges continued into Q1, Q2, and early Q3 2022, resulting in delays with full repair. Both compressor modules were online intermittently, while the Shell team made progress perfecting component and software performance, as well as fueling protocols. By September 2022, both compressor

modules were online and the station was experiencing some normal consistent throughput and steady operation.

Some of the challenges were identified as leaks on the hydrogen side of the compressors; on the hydraulic side, seal failures, bearing failures, hydraulic pump failures, and refrigerant compressor failures were also encountered. One ongoing issue was related to the cavity stack and diaphragm assembly within the compressor. The cavity stack and diaphragm assembly is a subsystem comprising layers of seals, gaskets, and diaphragms, and is needed for satisfactory compression. Another issue was with valve integrity, impacting system performance. The components were replaced, and the station modules were placed back online. In February, both modules were online and available for customer fueling. In March, one compressor module was down, due to a gasket replacement.. One remedy was re-machining internal surfaces to improve the seal. As standard maintenance protocol, gaskets were replaced. Filter degradation, causing particles to travel downstream in the process flow, may have also contributed to performance issues with the compressor modules, but were not proven to affect truck mechanisms.

The Shell team monitored and investigated each issue to ascertain whether there was a design issue, a component quality issue, or perhaps a fuel technique issue with installation or commissioning. The team continued to collect information, learn from the challenges, and make improvements moving forward. This was captured in a phased product improvement plan, by which Shell implemented engineered change management to the live station. The final station acceptance test to validate performance was a four-truck back-to-back consecutive fill, performed on October 26, 2022.

As an alternative fueling method, the cascade method was used when the compressors were offline, to service a truck fill in a situation where the truck would otherwise be stranded without fuel. A cascade fill uses the pressure in the ground storage tubes to move fuel through the system, loading fuel from higher pressure in the ground storage tubes into the lower pressure of the fueling vehicle tanks. This method works until pressures equalize and provides enough fuel for the truck to travel the distance to the next fueling station. Figure 25 shows one of the Ocean trucks at the Ontario station.

Figure 25. Project Truck at the Ontario Station



Photo Source: Shell

2.2.2.1 Technical Specifications

Each of the hydrogen stations has a refueling capacity of 1,140 kg per day. The station has two, single-hosed 700 bar dispensers on one fueling island and one single-hosed 350 bar dispenser on a second fueling island.

Shell selected Nel Hydrogen in Herning, Denmark to supply, install, and commission the hydrogen station equipment. Nel supplied the following major hydrogen station equipment: Station Module (containing the compressor and hydrogen cooling system), Storage Module and associated valve panels, supply cabinet and associated HMI, hydrogen dispensers and all interconnecting mechanical pipe and tubing between the equipment.

Other equipment such as the electrical switchgear, flame and gas detectors, CCTV cameras, and internet connection hardware were procured and installed separately and commissioned as part of the integrated system.

2.2.2.2 Status Update

The stations remain online and available for public-access refueling. Shell will continue to operate and maintain the HRS to support vehicle OEMs and fleet operators who intend to operate the FCEV trucks beyond the term of the funding agreement and through the end of the economic lifetimes of the trucks and station equipment. The station has and will continue to support further demand growth with capability to fuel trucks at 350 bar and 700 bar, providing access to multiple truck operators.

Shell aims to build on the successes of the HD HRS at Wilmington, Ontario, and the Port of Long Beach to start the full launch of a California-wide Heavy-Duty Hydrogen Refueling Network. The primary use-case for the network will be for Class 8 trucks, including drayage, medium-, and long-haul with intense duty cycles, and return-to-base operations.

2.2.3 Wilmington Station

The team mobilized for construction and pulled permits for the Wilmington site during Q2 2020. The Shell team installed camera feeds with real-time monitors at the build site. All work was conducted using appropriate PPE, hygienic practices, and safe distancing techniques. By May, the equipment was being fabricated and shipped to the site. The pre-construction meeting was held and the team mobilized and started the construction phase on May 18, 2020 beginning with excavation, backfill, and compaction.

The Wilmington station is a legacy site for Shell, in a heavily industrialized area, which lead to a challenge involving contaminated soil. Phase 1 and Phase 2 reports were prepared, identifying the area of contamination. Approximately 2,000 cubic yards of soil were profiled and exported to a proper waste site, causing a slight schedule delay.

In June 2020, the site continued with the early stages of grading, underground electrical, mechanical work, and forming and pouring foundations. Trenches leading to the fueling island were completed, electrical conduit installed, and interconnecting piping was welded and lowered into the trenches. Pit boxes for the hydrogen dispensers were set.

By October 2020, the Wilmington station was mechanically complete, except for the transformer and vault for DWP. DWP completed its survey and was originally scheduled for August 2020 to pick up power from the overhead lines, run the power along the new poles, drop conductors down into Shell's transformer, pull feeders over to the switch gears, and power up the station. DWP was originally scheduled in August 2020. By November 2020, DWP was working on an enclosed area with the transformer. Of the eight poles, six were erected. The secondary power and meter were approved in November by the City Inspector. In early December, the remaining poles were erected, the overhead wires were pulled to terminate at the transformer, and the transformer was set, making the station ready for the next phase of pulling the secondary lines from the transformer to the switchgear, which would render the station live with power.

During Q4 2020 and into Q1 2021, additional COVID-19 restrictions resulted in appointment cancellations and scheduling delays at Shell's Wilmington station build. DWP schedules were heavily impacted by the wildfires and COVID-19 restrictions, causing power delays at the Wilmington site.

By January 2021, DWP crews brought in the secondary lines, pulled the lines through the conduit, and brought power to the site. The station was energized on January 7, 2021. The Pre-Start Up Safety Review took place on January 18. The station modules and internet systems were powered up. The Pre-Start Up Safety Review punch list items were completed in March. In March, the I/O checks began, and the safety systems check for the Fire Department

permit were completed in May. Software upgrades were downloaded in April. The Shell/Nel safety systems check took place on April 30. Nitrogen purge of the storage tanks and the station compression and thermal management modules took place on May 20. The initial Fire Department safety inspection was completed on May 24 and punch list items were finalized in June. On June 23, the station passed the Fire Department safety inspection, and a trailer load of hydrogen was scheduled for introduction into the tubes. Figure 26 provides an aerial view of the Wilmington station.

Figure 26. Aerial Photo of the Wilmington Station



Photo Source: Shell (aerial drone)

In July 2021, the Wilmington station was ready for the introduction of hydrogen, but was resource limited by the equipment supplier, Nel. The first shipment of hydrogen from Air Products was received on August 24, 2021. Commissioning activities began in August 2021 and continued through Q3 2022. This phase of commissioning activities tested the capabilities of the system to compress hydrogen and other tests such as hydrogen quality testing, DMS testing, HyStEP testing, and performance testing. Upgrades to the stations continued, including software upgrades, to increase performance.

During Q2 2022, the station continued undergoing commissioning activities and moved into performance testing. The station completed DMS testing in April 2022. Fueling tests using two Ocean trucks successfully took place in late May. The two trucks were at approximately 10% fuel and tested back-to-back using dual nozzle fueling. The commissioning data was reviewed and approved by Toyota, from both a safety and performance standpoint.

The variable frequency drive (VFD) continued to be an issue, while the station waited for personnel availability to support the repair. Repairs were completed for one of the modules in April and the other in May 2022. In early June, modifications were performed on the carbon dioxide (CO₂) lines, which help to cool the hydrogen on route to the dispensers. Additionally, a

valve was replaced prior to the system being recharged with CO₂. Wilmington was online for soft opening July 14, 2022. On September 13, 2022, three trucks successfully completed the back-to-back fill protocol as a proof point for station readiness. The four-truck back-to-back consecutive fill station acceptance test was subsequently performed at Wilmington on November 09, 2022. Timing is attributed to a full station acceptance testing program across the stations; the Port of Long Beach (POLB) Portal Station filled two trucks back-to-back on September 26 and four trucks on September 28, 2022, while the Ontario station filled four trucks on October 26, 2022. Figure 27 shows some of the Ocean fleet trucks at the Wilmington station.

Figure 27. Photo of the Wilmington Station



Photo Source: Shell

The overall engineering development program continues to review status of the fueling stations. All failures that occur are logged and studied for similar and repeated issues, then searched for groupings and repeated issues. Based on the issues, frequency, and amount of time to repair, the issues are rank-ordered and prioritized for resolution. Ongoing engineering improvements took place across all fueling sites with upgrades to hardware and software. The Nel Hydrogen facility in Denmark focused on eight upgrades, with implementation completed in Q3 2022. These upgrades improved reliability and increased the performance for faster fills with fewer trips.

The station acceptance testing was successfully completed at all three sites, allowing the stations to move from soft open to hard open, enabling 24-hour unstaffed operations. Figure 28 shows an Ocean truck at the Wilmington station.

Figure 28. Project Truck at the Wilmington Station



Photo Source: Shell

2.2.4 Port of Long Beach Portal Station

Although the Long Beach Portal Station was not funded by CARB and was not a direct part of the ZANZEFF S2S project, costs for the station build were used as match share contribution. Portal Station supported Ocean truck operations by fueling FCEV trucks when needed.

Assembly Bill 118 (Núñez, Chapter 750, Statutes of 2007) created the Clean Transportation Program, formerly known as the Alternative and Renewable Fuel and Vehicle Technology Program. The statute authorizes the CEC to develop and deploy alternative and renewable fuels and advanced transportation technologies to help attain the state's climate change policies. Assembly Bill 8 (Perea, Chapter 401, Statutes of 2013) reauthorizes the Clean Transportation Program through January 1, 2024, and specifies that the CEC allocate up to \$20 million per year (or up to 20 percent of each fiscal year's funds) in funding for hydrogen station development until at least 100 stations are operational.

Shell built a hydrogen fueling station for heavy-duty vehicles, located at the existing Toyota Logistics Services Terminal at the Port of Long Beach. Shell is the operator of the station.

Under its Grant Funding Opportunity GFO-17-603, the CEC funded 66.7% of the total budgeted cost of the station while Shell provided the balance for a total budgeted station cost of \$12,001,800. The CEC contributed \$8,000,000. Actual station build costs exceeded \$13 million.

The hydrogen station has a refueling capacity of 1.5 tonnes per day. The station has two single-hosed 700-bar dispensers on one fueling island and one single-hosed 350-bar dispenser on a second fueling island.

The heavy-duty hydrogen station also feeds a light duty hydrogen refueling station for private use by Toyota Logistics Services to complete pre-delivery hydrogen fills of production Toyota Mirai FCEVs off-loaded from marine vessels at the port facility, prior to road transport distribution to dealerships for delivery to public customers. The light duty station has one, single-hosed 700 bar dispenser on one fueling island.

Shell's project team comprised Fiedler Group as engineer of record and constructor, Fueling and Service Technologies, Inc. (Fastech) as general contractor, and Nel Hydrogen as equipment vendor, commissioning engineer, and operations and maintenance contractor.

The hydrogen station equipment, supplied by Nel Hydrogen, attained a UL Certificate of Compliance on May 1, 2020. It is the only commercially available, heavy-duty vehicle, hydrogen refueling station with UL certification. This certification applies to all stations conforming to this design.

The station took 22 months to achieve an "Operational Station" status, from the time of plan check submission with authorities having jurisdiction (AHJ) to the "Operational Station" date of July 1, 2021. The first fueling of a heavy-duty FCEV was done on June 11, 2021.

Shell initiated site acquisition negotiations with Toyota Logistics Services. An agreement was executed on February 23, 2018.

Pre-application meetings were initiated with the AHJs in May 2019. An entitlement application package was submitted by Toyota to the AHJ in November 2017. Entitlement approval was received in August 2018. Plan check was submitted to the AHJ in September 2019. Two rounds of plan check comments were received from the building department. The building department's approval was obtained in March 2020.

Shell initiated equipment procurement with Nel Hydrogen in November 2018. Time-phased, on-site delivery and installation of equipment was completed in August 2020. Construction mobilization occurred in March 2020. The station, with all hydrogen equipment installed, was ready for a pre-startup safety review (PSSR) in August 2020. Pre-commissioning activities began on September 23, 2020, and the first heavy-duty vehicle was filled on June 11, 2021. The required 1-year retail operational period started on July 1, 2021, with the station remaining retail open after this period. A four-truck station acceptance test was completed on September 28, 2022.

Shell will continue to operate and maintain the hydrogen refueling station to support Toyota and the committed fleet operators who intend to operate the FCEV trucks beyond the term of

the funding agreement and through the end of the economic lifetimes of the trucks and station equipment.

2.3 Port of Hueneme Project

POH provided a unique opportunity to demonstrate advanced technology cargo handling equipment in a relatively compact port environment. The S2S project provided two Kalmar yard tractors, the first heavy-duty zero-emissions equipment utilized at POH. Additionally, the project funded the development of charging infrastructure to support the yard tractors and infrastructure to support two Liebherr 420 hybrid-electric cranes. The crane vaults were partially funded by a Carl Moyer Program grant through the Ventura County Air Pollution Control District (APCD).

POH views Southern California Edison as the main partner for the infrastructure redevelopment project, since the project is predicated on expanding the capability for voltage load available at the wharf near the cargo handling area. Engineering designs were based on preliminary discussions with Southern California Edison and initial estimates based on their availability. POH experienced a two-fold problem, driven by wildfire response and COVID-19 restrictions. From the initial stages, starting with the technical engineering groups, the project experienced delays. Design conflicts were surmountable for the 480 voltage service, required for the yard tractors. However, the 4,160 voltage service needed for the additional crane vaults continued to experience delays. POH proposed to bifurcate the schedule into a yard tractor track and a higher voltage track. The yard tractor infrastructure remained close to the proposed schedule, with an estimated 6-month delay. The 4,160 voltage electrical service for the e-cranes experienced a delay of more than a year.

2.3.1 Yard Tractors

Through an RFP, POH selected Kalmar to provide the yard tractors. During Q2 2020, several members of the Kalmar staff, regular contacts for POH, were unavailable due to COVID-19 restrictions. This resulted in postponement of finalizing the purchase proposal. In June 2020, conversations moved forward, yard tractor specifications were defined, including a five-battery pack, the highest available rendition. Negotiations were lengthier than anticipated for the additional battery bank box added to each yard tractor, which was necessary to ensure operational endurance through the complete duty cycle. The fifth battery bank added about \$70,000 to each yard tractor. Kalmar anticipated manufacturing and delivery delays, due to COVID-19 restrictions, but committed to meeting a 6-month timeline from order to delivery. The quote and associated paperwork was presented to the POH Board on July 20, 2020, and was approved.

The two Kalmar yard tractors were delivered on June 22, 2021. Coordination with PMA and Labor began in January 2021; POH worked on MOU information with the stevedores regarding utilization of the yard tractors. With the charging infrastructure electrified and the yard tractors commissioned, operator training took place November 4 and 5, 2021. Demonstration was scheduled to begin early January 2022; however, the local president of ILWU passed away. His absence, along with the personal impact, created a gap in procedures. Additionally, the

COVID-19 Omicron variant impacted availability of workers. January 24, 2022, marked the first day of operational use moving cargo with the battery-electric yard tractors. (Figure 29).

Figure 29. Kalmar Battery-Electric Yard Tractors



Photo Source: Port of Hueneme

On February 4, 2022, a faulty coolant sensor prevented yard tractor #266 from charging. Cal-Lift came out on February 7 and promptly replaced the sensor.

In mid-March, yard tractor # 265 hit a pole while operating and damaged the battery plug box. Although the unit was still functionally operational, due to safety concerns the unit was sidelined until repaired and inspected. Due to long lead-times, parts acquisition was delayed until April, when the yard tractor was repaired and returned to fully operational status. In response to the battery pack vulnerability and the heavy impact of terminal use on the equipment, POH explored retrofit armoring for the battery pack area. Attempts to explore options with Kalmar on a retrofit solution were protracted, which inspired POH to fabricate a solution in-house. (Figure 30)

By the end of Q3 2022, Unit #265 operated a total of 57 days and #266 operated 77 days. The two yard tractors cumulatively operated 1,401 hours and drove over 2,000 miles (for detailed data refer to Section 3). The yard tractors were able to operate for two shifts per day, with opportunity charges throughout. Ultimately, understanding opportunity charging needs will shape utilization of battery-electric equipment on a larger scale.

Figure 30. Electric Yard Tractors with Battery Pack Protection Covers



Photo Source: Port of Hueneme

2.3.2 Yard Tractor Infrastructure

Infrastructure for the yard tractors went out to bid in Q3 2020. Site construction for the 480 service to power the yard tractors was set to begin in January 2021 but delayed due to rain and high winds. By February, the contract was in place and the initial infrastructure phase for the yard tractors was underway. The infrastructure construction to support the yard tractors was completed in June 2021 and was then waiting for power from Southern California Edison. During Q3, Southern California Edison cancelled several scheduled dates to complete the project. Electrification of the infrastructure took place on October 20, 2021.

2.3.3 E-Crane Charger Infrastructure

Infrastructure for the higher voltage crane vaults was set to go out to bid in late January 2021. POH internal discussions took place during Q1 2021 regarding final placement of a concrete pad adjacent to the transformers. The question involved future planning and space considerations for the location, as space is at a premium. To minimize impacts to terminal operations, POH evaluated the realities of the construction process: managing installation, vault location, timing of construction, and numbers/cost. With placement considerations resolved, the project continued to anticipate availability of Southern California Edison. The infrastructure construction bid package closed May 10, 2021, and final contract negotiations took place.

Construction for the 4160 service began on February 16, 2022, and was completed November 26, 2022. The project was modified to include two vaults, rather than the original three vaults, due to cost increase. Cost estimates for the infrastructure increased by several million dollars from the original proposal to over \$7 million, largely due to supply chain issues and rising material costs. Funding through the Ventura County APCD was granted to supplement the cost

for one of the vaults. Notably, additional vaults would require Southern California Edison to increase the power supply.

In late February 2022, the construction team hit ground water earlier than expected. They continued to battle the ground water into March, April, and May, anticipating at least a 3-week delay. The construction change order was processed in March and expected to cost six figures for the modifications. During May, dewatering associated with the installation of Southern California Edison infrastructure continued. Water was kept out of the cast during concrete pours; additionally, there were some issues procuring concrete, which was in short supply. In late May 2022, construction met the next challenge of wharf installation of the vaults. The laydown area on the wharf is about 45' x 75', a large area on a working waterfront. Shutting down the wharf is not a viable option; POH must instead orchestrate ways to manage throughput, while safely implementing infrastructure development (Figure 31).

Figure 31. Q2 2022: Crane Vault Infrastructure Construction



Photo Source: Port of Hueneme

In 2021, two of the port’s stevedores purchased two additional Liebherr 420 hybrid-electric cranes to increase utilization of the vaults (Figure 32).

Figure 32. Q1 2022: Liebherr 420 Hybrid-Electric Crane



Photo Source: Port of Hueneme

2.4 Battery-Electric Forklifts

TLS deployed battery-electric forklifts for project demonstration. In addition to propane forklifts, TLS operates five 36V lead acid battery-electric forklifts with a maximum capacity of 3500 lbs., one of which was purchased as part of the S2S project (for specifications and data analysis see Sections 3.6 and 4.1.4). No electronic data are available from these units and indoor usage renders GPS nonfunctional. As such, daily safety and operations logs are being used to compare usage of electric and propane lifts. These daily usage rates will be used to provide a rough estimate of energy use.

Section 3: Data Collection & Analysis

In-use data collection for baseline and advanced vehicles—including 10 hydrogen fuel cell electric trucks, two electric yard tractors, and two hydrogen fuel cell forklifts—was performed to understand the benefits of the advanced technology vehicles. Both maintenance and infrastructure data were collected from the team to understand the broader impact of advanced vehicle adoption.

3.1 Data Collection Test Plan

Trucks were equipped with a data logger that records GPS and CAN data conforming to the SAE J1939 standard. The data collection included GPS, fuel efficiency (miles/kWh), mileage/odometer readings, run time, idle time, speed, and ambient temperature. Field data collection was sufficient to meet the project requirements, providing information such as:

- **Vehicle specification:** These were recorded for each test vehicle including manufacturer, model, model year, and fuel proposal system.
- **Fuel/energy consumption:** Using a combination of vehicle data, refueling logs, and infrastructure information, calculated summary statistics including fuel/hydrogen use, fuel price, propulsion energy, and fuel efficiency.
- **Vehicle maintenance and operations:** Monthly logs of baseline vehicle maintenance and operations, where available, were consolidated with the data set. A summary of Ocean truck maintenance activities was also provided at the end of the demonstration. This included the type of maintenance (scheduled, unscheduled, configuration change) and the repairs done. Detailed maintenance data included, as available, date, description of problem, repairs performed, parts replaced, cost of parts, labor hours, and cost of labor. One operator also provided payload records for their baseline trucks and the Ocean trucks they operated.
- **User and fleet experience:** User/fleet experience was quantified through a driver survey. This included questions related to vehicle availability, performance (power and energy) to meet operation demands, perceived safety, refueling experience, and other barriers.
- **Facilities performance:** This was quantified through data collection on facility electrical demand hydrogen dispensing for the hydrogen fueling stations.

3.1.1 On-Vehicle Data Collection

Onboard data collection devices were installed on the demonstration and baseline vehicles to capture appropriate and necessary data from the vehicles for the length of the test. Kenworth provided loggers for their demonstration vehicles, while NREL provided loggers for the baseline vehicles. Hydrogen infrastructure associated with the ZANZEFF vehicles was

instrumented by the infrastructure service provider as needed with appropriate data loggers to provide electrical and hydrogen energy use data. Frequency of data transmission from vehicles and infrastructure to data servers depended on file size. NREL's existing electronic data collection and analysis system was used to automate filtering and uploading into NREL's Fleet DNA data repository,¹ which was used to process the data and provide summary reports described in later tasks. NREL's in-house data processing capabilities include:

- Automated, secure data transfer from Vector loggers to NREL's secure commercial fleet data center
- 25 TB of data storage arrays on a redundant virtual machine
- NREL's Fleet DNA Fleet Analysis Quick Statistics.

3.1.2 Operation and Maintenance Data Collection

Maintenance and operation cost data/records were supplied by the manufacturer for the Ocean trucks and by some fleet operators for a subset of baseline drayage vehicles.

3.1.3 Infrastructure

NREL received information provided by project partners characterizing the hydrogen fueling stations. In addition to station specifications, the data provided by the infrastructure partners included station performance data such as monthly quantity of fuel compressed and dispensed, monthly electrical energy used by the hydrogen stations, monthly total electricity cost, and individual fueling records with fueling times and hydrogen quantities. Driver/operator feedback on hydrogen refueling was captured in the driver survey.

3.1.4 Data Collection Summary

The collection was conducted in accordance with the proposed plan between July 2020 and December 2022. NREL worked with the team to collect baseline data for conventional Class 8 drayage operations out of POLB and POH, yard tractor operating at POH, and propane forklifts at POH. Maintenance data for a subset of the baseline fleets were collected when available. Data were collected on all 10 Ocean FCEV trucks, the two battery-electric yard tractors at POH, and electric forklift operations at POH. Ocean FCEV maintenance data were provided by Toyota. User surveys were collected for the Ocean trucks for 30-day and 90-day feedback. The team was unable to get driver feedback on the electric yard tractors due to ongoing union negotiations. Shell provided data on the station operations and maintenance.

Details on this data collection and analysis of findings are provided in the following sections.

3.2 Baseline Data Collection

The baseline tractor data collection was conducted by NREL. The following analysis shows data for 2 years starting in June 2020 and ending in September 2022. The data loggers collected over 722,000 miles of data consisting of 195 million data points over 4,257 vehicle days. The

¹ "Fleet DNA Project Data." (2022). National Renewable Energy Laboratory. Accessed December 11, 2022: www.nrel.gov/fleetdna

baseline data set for tractors in drayage service had an average daily distance of 170 miles and average fuel economy of 5.8 mpg. Table 22 shows the high-level analysis of the collected baseline data broken out by fleet. Fleets 1–4 are Class 8 tractors performing drayage operations, which take containers from a terminal to an outlying warehouse. Conditions for these vehicles can range from stop-and-go creeping while waiting to load a container to highway driving and mountainous driving over the California Grapevine. Fleet 5 consists of yard tractors operating within the port terminal moving containers from a ship to a stack in a repetitive manner and limited to under 25 mph.

Table 2. Data Collection Summary – Baseline Vehicles

Description	Fleet 1	Fleet 2	Fleet 3	Fleet 4	Fleet 5
Number of Vehicles Logged	16	16	9	20	10
Vehicle Type	Drayage	Drayage	Drayage	Drayage	Yard Tractor
Total Miles Logged	265,350	199,349	106,889	142,910	4,218
Number of Active Days Logged	1,230	815	676	671	262
Avg. Daily Moving Speed [mph]	40.6	31.3	28.5	32.7	6.5
Avg. Daily Distance [mi]	215	244	158	213	16.1
Max Daily Distance [mi]	547	726	582	680	47.1
Average Miles per Gallon	5.8	7.2	7.4	5.0	2.7
Avg. Daily Engine Run Time [h]	6.4	8.5	7.0	10.0	5.5
Avg. Daily % Idle	21.0	21.3	24.0	37.1	52.8
Flywheel Energy [kWh]	587.2	475.3	335.3	511.8	56.0
Avg. Daily % Energy at Idle	5.0	3.1	1.6	5.0	15.7

3.2.1 Baseline Class 8 Tractor Drayage Duty Cycles

Understanding the baseline operation is important for identifying improvements of the advanced technology. For the Class 8 tractors performing drayage operations, distributions of daily average driving speed and daily distance broken down by fleet are shown in Figure 33. Fleet 1 had the highest daily average speed around 40 mph, while the other fleet averages were closer to 30 mph. This is likely due to more sustained highway speeds. In terms of daily distance, the average for all vehicles were below 250 mi; however, these fleets had maximum daily distances from 547 mi to 727 mi. To fully match this operation any new technology must be able to accomplish these longer operations if no change in operation is made.

Figure 33. Distribution of Daily Average Speed (left) and Daily Distance (right)

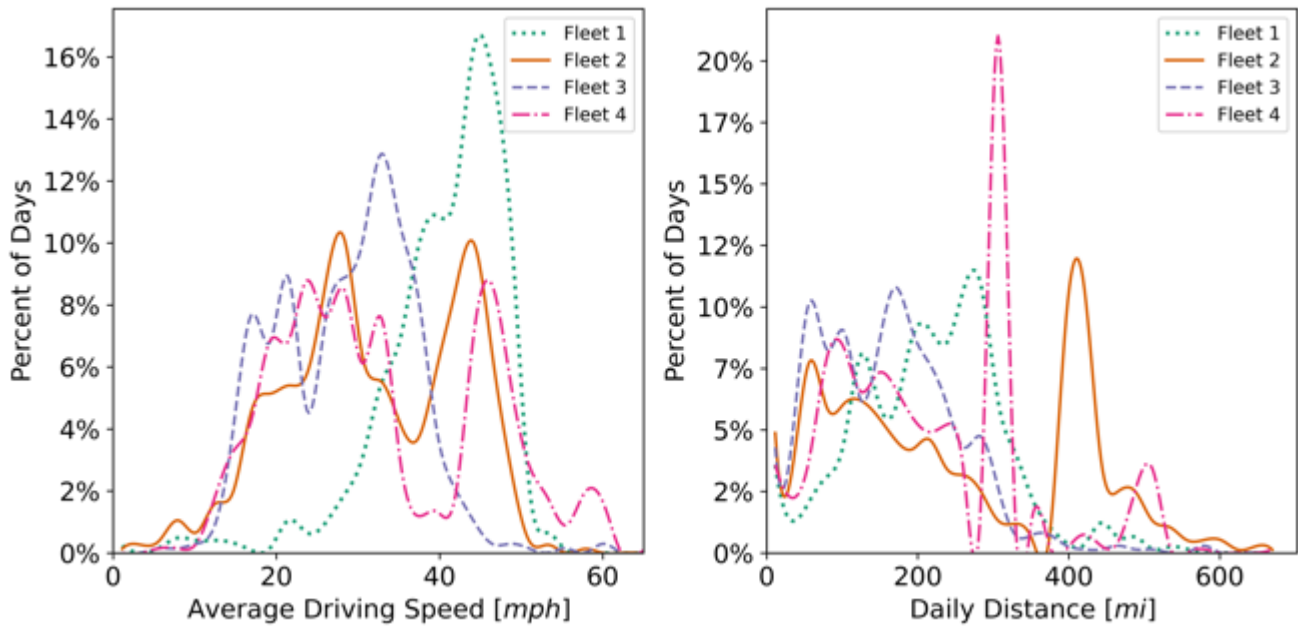

Next, we examine the baseline fuel economies of the fleets. Data in Figure 34 show daily average fuel economy range from 3 to 10 mpg with fuel rates between 1 and 8 gal/h. The lowest fleet average fuel economy was 5.0 mpg for Fleet 4 and up to 7.4 mpg for Fleet 3. The likely difference between the two is explained by the differences in operation and duty cycle.

Engine run time is another important metric to examine when switching to advanced technologies. Distributions of daily engine run time are shown in Figure 35 for each of the fleets, with Fleets 1 and 3 having operation up to 12 hours and Fleets 2 and 4 operating up to 20 hours, which is consistent with drayage operation and an opportunity for energy reduction through vehicle electrification since electric vehicles use little energy at idle.

Figure 34. Distribution of Fuel Economy (left) and Fuel Rate (right)

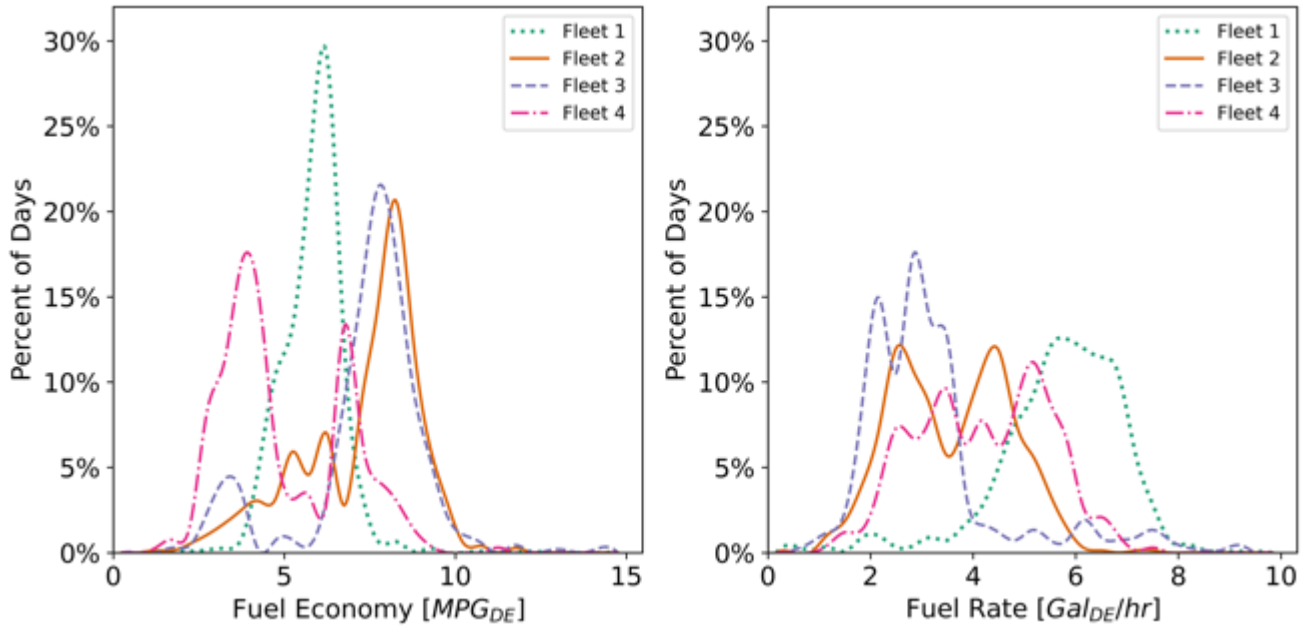
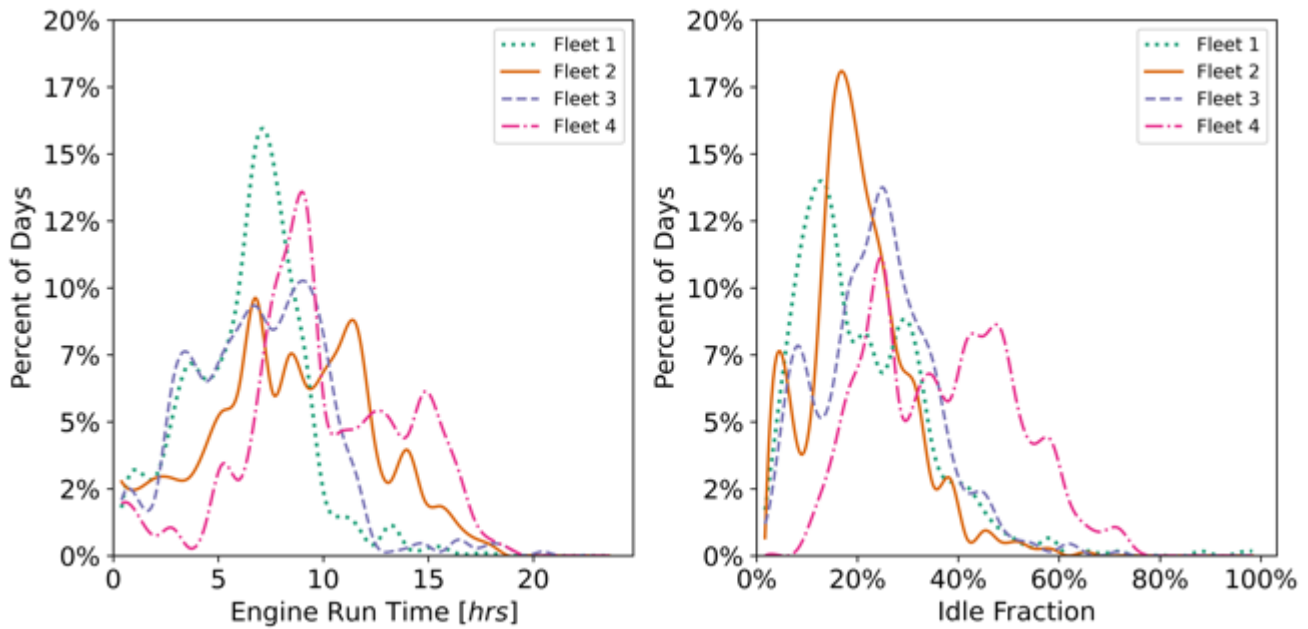

Figure 35. Distribution of Daily Engine Run Time (left) and Percent Idle (right)



Vehicle flywheel energy, which is the estimated energy produced at the output of the engine, is an important metric for understanding the scale of energy needed when converting to an electrified vehicle. While conventional vehicles do not have the ability to recapture energy, flywheel energy is an estimate for the vehicle and operation's positive tractive energy requirement. Figure 366 shows the daily flywheel energy production for each fleet with averages between 335 kWh and 590 kWh, suggesting that electrification will be challenging.

Further, the maximum daily flywheel energy was 1,600 kWh, which is extremely challenging. Despite this large flywheel energy production, up to 40 kWh of that is produced at idle, meaning electrification would have up to a 40-kWh reduction in energy use because electric vehicles use very little energy at idle. Further, these numbers do not consider regenerative braking, which has been estimated to be around 15% of total energy use for regional haul operation and would likely be higher for slower-speed drayage operation. While these conditions may be challenging for battery-electric vehicles to accomplish within a day given the constraints on charging times and driver hours of service requirements, fuel cell electric tractors may be able to achieve these longer distances due to the shorter fueling times. While H₂ infrastructure is not ubiquitous yet, these daily energy needs may be accomplished once more stations are available throughout the trip.

Figure 36. Distribution of Daily Flywheel Energy (left) and Idle Energy (right)

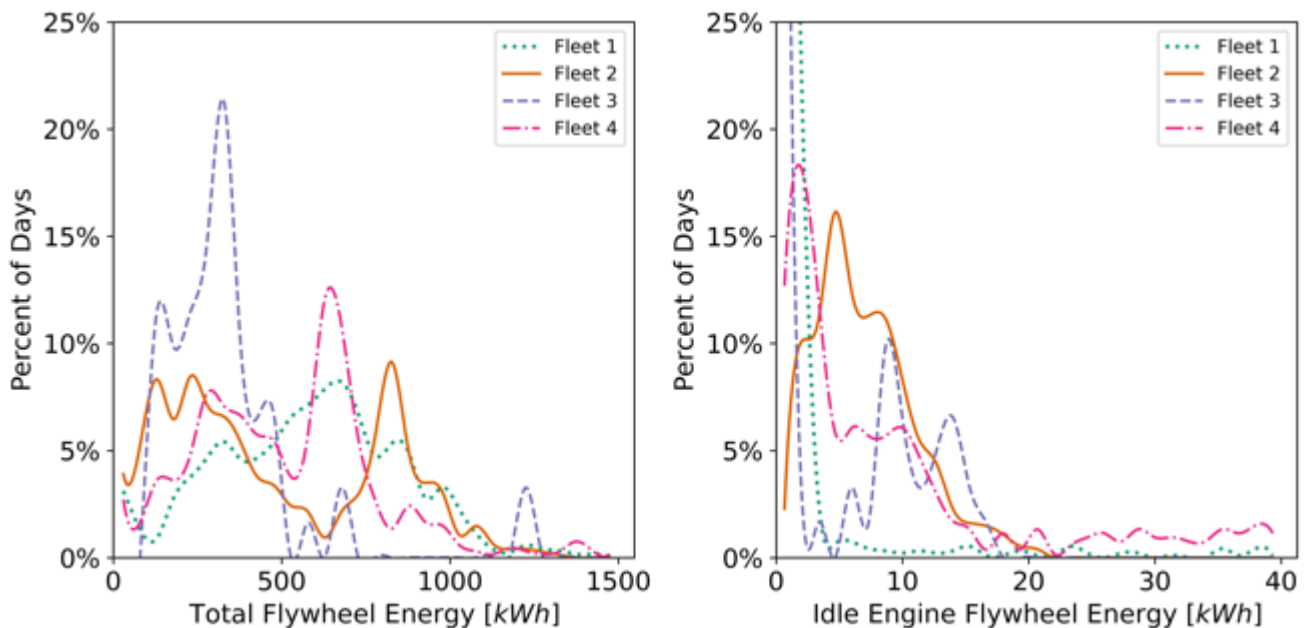

3.2.2 Baseline Yard Tractor Operation

Using the same data collection methods and baseline duty cycle analysis methods as the drayage trucks, this section explores the requirements behind baseline diesel yard tractor operation. Daily average speed and daily distance are shown in Figure 37, with the average vehicle speed around 3 mph and average daily distance of 16 mi. While the speed and daily distances are low and typical of yard tractor operation, this work typically involves frequent idle and creep (stop-and-go) scenarios, which can be inefficient for internal combustion engine vehicles.

Figure 37. Distribution of Yard Tractor Average Speed (left) and Daily Distance (right)

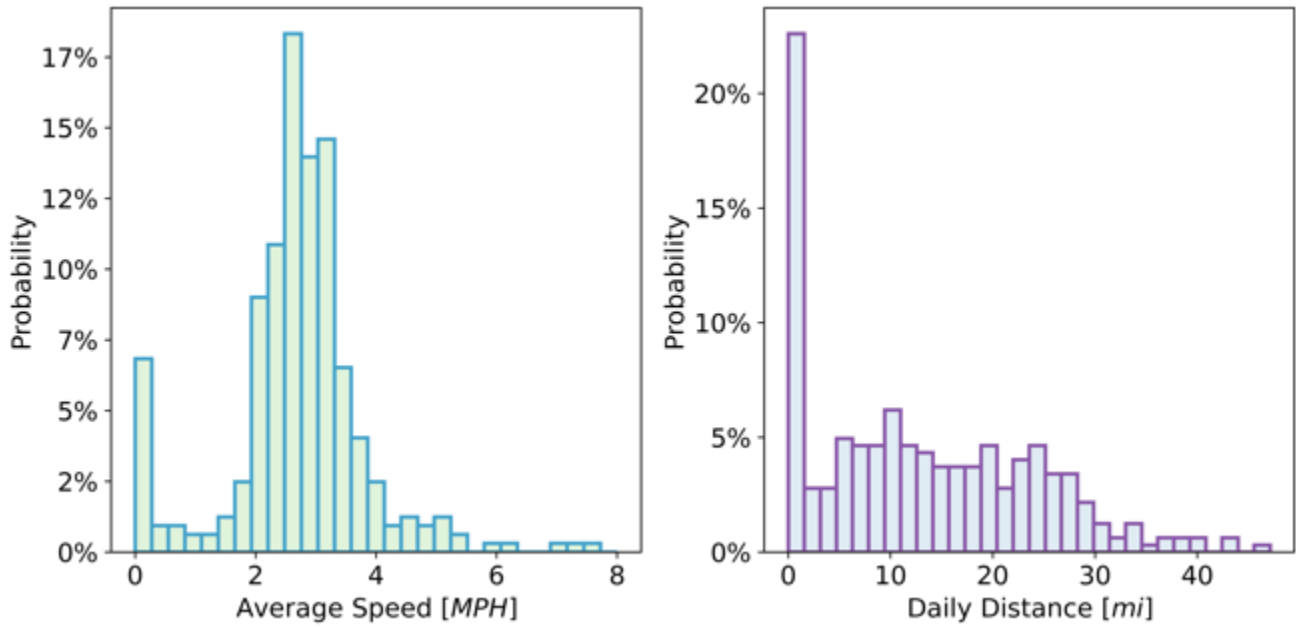
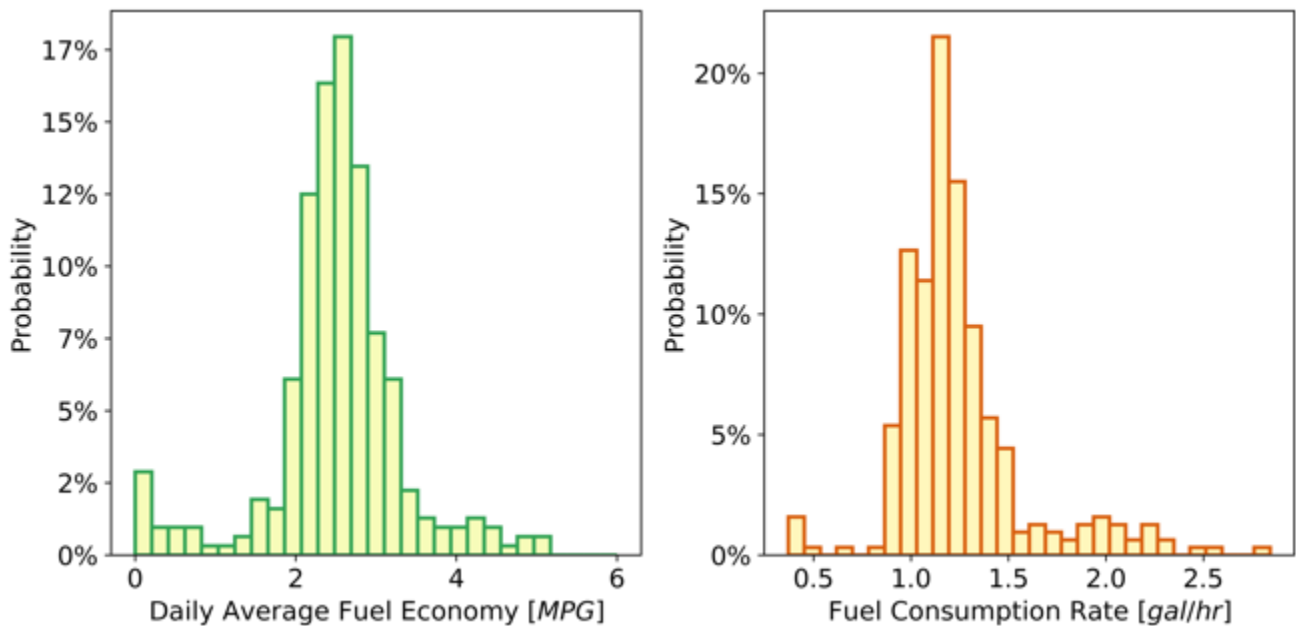

Figure 38. Distribution of Yard Tractor Fuel Economy (left) and Fuel Rate (right)

Average fuel economy of the yard tractors was around 2.7 mpg with an average fuel rate around 1.2 gal/h, resulting in an average daily fuel use of 6.2 gal (Figure 38). These numbers are consistent with slow operation and substantial idle.



Engine flywheel energy, or energy produced by the engine at the flywheel, provides an initial look at the scale of battery needed for electrification. Based on the captured data, Figure shows the average daily flywheel energy was around 56 kWh with a max of 150 kWh. However, 8.7 kWh on average is produced at idle, which would be a direct reduction for an electric yard tractor because they use very little energy at idle. These specifications are within the available yard tractor battery sizes of 220 kWh.

Figure 39. Distribution of Daily Yard Tractor Engine Flywheel Energy (left) and Idle Energy (right)

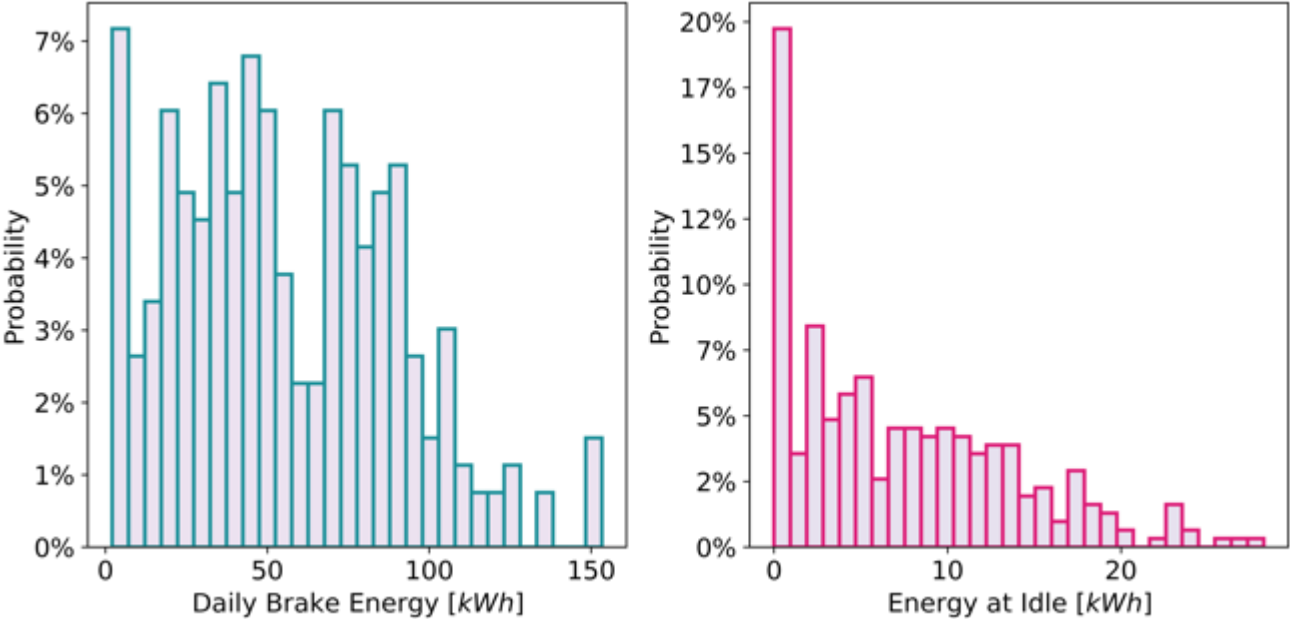

3.2.3 Baseline Truck Operation and Maintenance

3.2.3.1 Fleet 1

NREL received operation and maintenance data from Fleet 1 covering December 2020 through November 2021 for its diesel truck fleet. The data files included vehicle fueling records, payload records, and maintenance cost records. Fleet 1 also provided historical fueling and payload data (January–October 2020) from one compressed natural gas (CNG) truck for reference. NREL received limited payload data from some of the Ocean trucks between June and November 2021.

Baseline Truck Fueling

Throughout 2021, Fleet 1 experienced steadily rising diesel prices, from \$3–\$5 per diesel gallon, averaging \$3.99 per gallon during the data collection period (Figure 4040). Historical CNG prices were approximately \$4 per diesel gallon equivalent in 2020. The diesel fleet had an average fuel economy of 6.1 mpg. Per-mile fuel costs for the diesel fleet fluctuated based on fuel price and fuel economy, but were typically around \$0.60–\$0.80 per mile (Figure 441).

Figure 40. Fuel Price for Conventional Trucks, Fleet 1

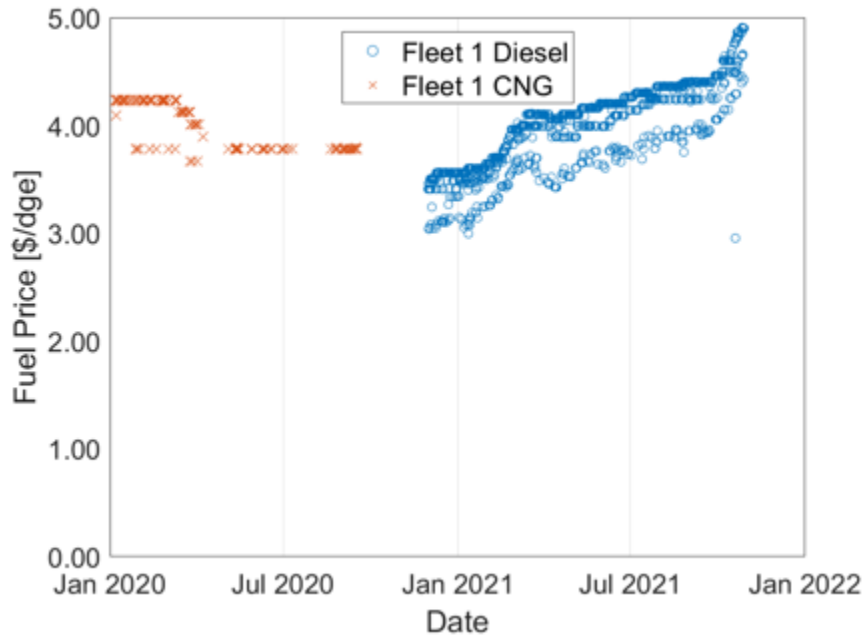
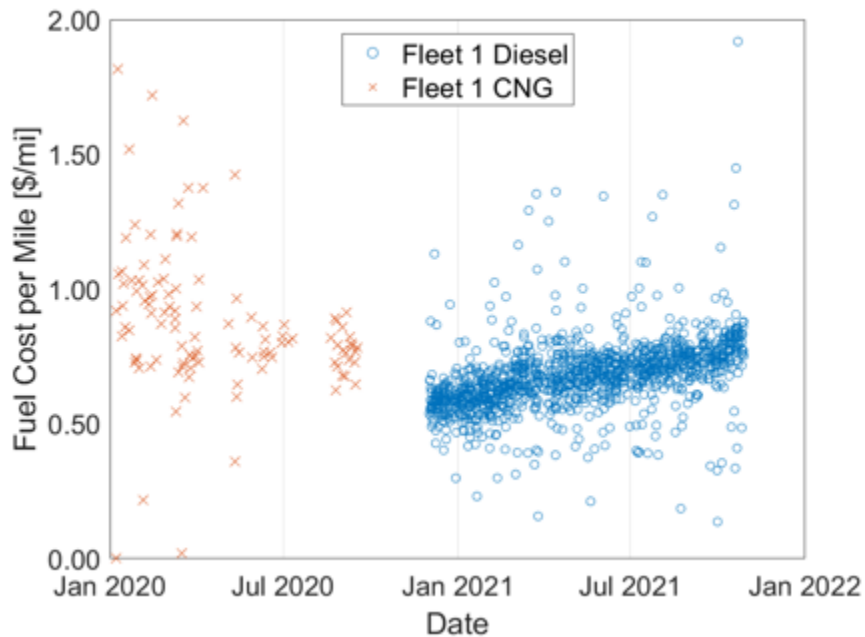
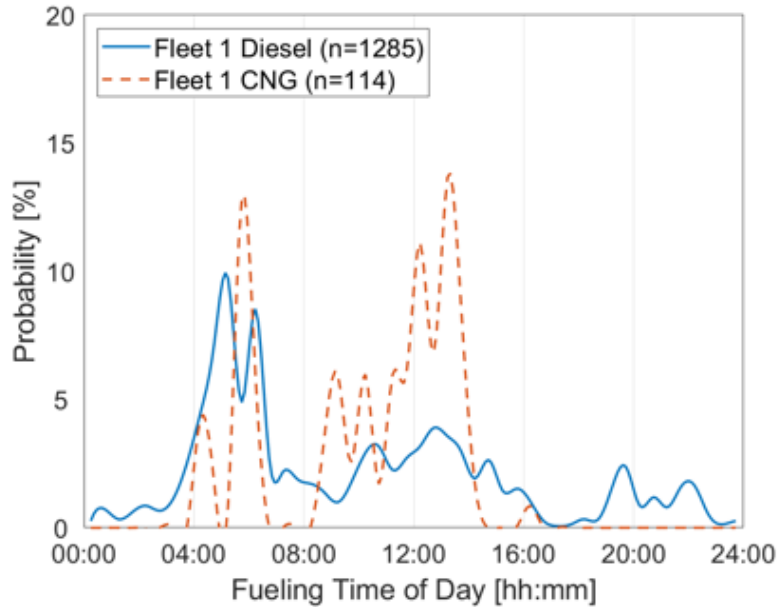

Figure 41. Fuel Cost per Mile for Conventional Trucks, Fleet 1



In terms of fueling behavior, the distribution in Figure 42 shows that diesel trucks at Fleet 1 typically refueled early in the morning, between 4:00–7:00 a.m., with some fueling events scattered throughout the day and late evening. The one CNG truck showed a preference for refueling either at 6:00 a.m. or during the middle of the day. The fueling records also showed that the diesel trucks typically take less than 10 minutes to refuel.

Figure 42. Fueling Time of Day for Conventional Trucks, Fleet 1



The fueling records indicated that the diesel trucks traveled much farther between refueling events than the CNG vehicle—in many cases achieving 600 miles or more—while the CNG vehicle rarely traveled more than 250 miles before refueling. This difference is dependent on the fuel capacity and the scheduled operation of the trucks and does not necessarily reflect the maximum distance the vehicles are capable of traveling. Additionally, fueling events that were unrecorded or missing from the data set could indicate a longer distance between refueling events than a vehicle is capable of traveling (Figure 43).

Figure 43. Distance Between Fueling Events for Conventional Trucks, Fleet 1

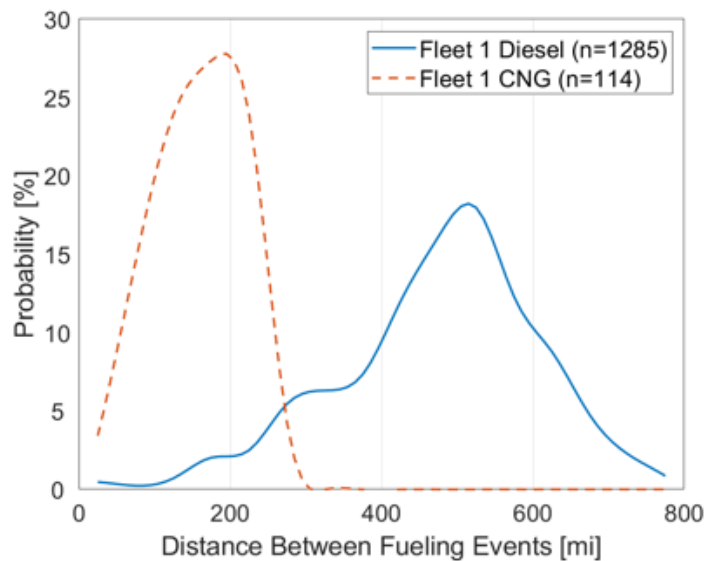

Cargo/Payload Weight

Figure 44 shows a swarm plot of the cargo weights for 19 diesel trucks (labeled FCxx), four Ocean trucks (labeled HFxx), and the CNG truck (NG01). The conventional trucks typically pull trailers with 30,000–35,000 lbs. of payload, whereas the Ocean trucks during this demonstration pulled trailers weighing between 20,000 and 30,000 lbs. The lower payloads of the Ocean trucks are due to the limited capacity of the car hauler trailers. The car haulers used for the Ocean trucks hold fewer vehicles than those hauled by the conventional trucks due to space constraints caused by the hydrogen fuel tanks for this prototype vehicle, which could be resolved in the design of the final production form.

Figure 44. Cargo Weight for Conventional Trucks, Fleet 1

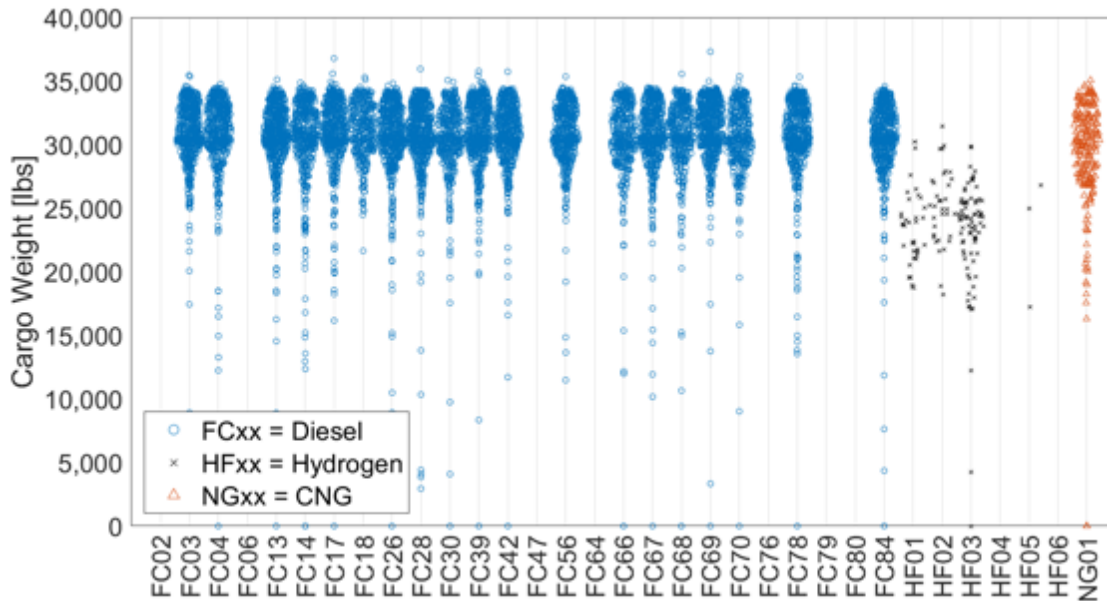

Maintenance Costs

Cumulative maintenance cost per mile for each diesel truck is shown in Figure 45. The maintenance data included records marked as truck maintenance, as well as trailer maintenance. Each cost was included in one of five cost categories (shown in the figure in order from top to bottom): Tax, Miscellaneous, Vendor, Parts, or Labor. The combined costs per truck range from approximately \$0.20–\$0.70 per mile, averaging \$0.38 per mile during the data collection period. Comparable data were not available for the CNG and hydrogen trucks.

Figure 45. Maintenance Cost per Mile for Diesel Trucks, Fleet 1

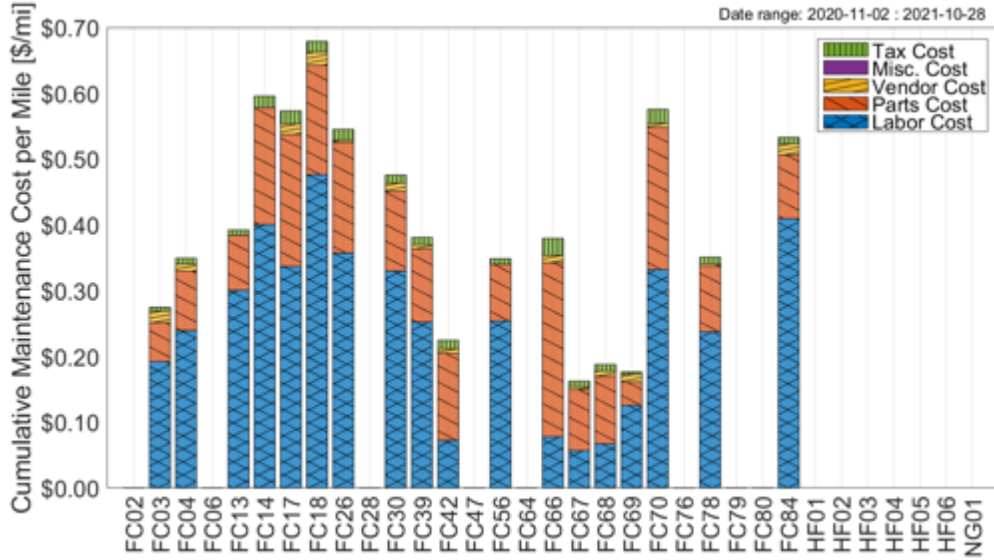

3.2.3.2 Fleet 4

NREL received fuel records from Fleet 4 for its conventional truck fleet covering most of calendar year 2021. The fleet includes diesel, CNG, LNG, and a few hybrid trucks. The diesel fuel records did not contain odometer information to calculate distance between fueling events, fuel economy (mpg), or fuel cost per mile for the diesel fleet.

Baseline Truck Fueling

Fueling records from Fleet 4 indicate that fuel costs were slowly rising for all fossil fuel types during 2021 and generally cost between \$4–\$5 per diesel gallon equivalent for all natural gas-fueled trucks and between \$2.50–\$3.50 per diesel gallon for the diesel trucks (Figure 46).

Figure 46. Fuel Price for All Conventional Trucks, Fleet 4

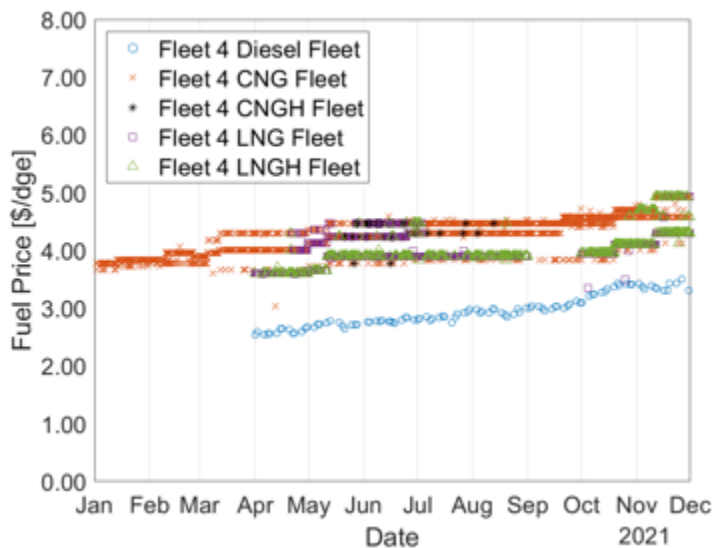

Figure 4747 shows the distribution of distance traveled between fueling events for the Fleet 4 conventional vehicle fleet. The behavior is very similar for all fuel types shown, indicating consistent routes and consistent fueling patterns for the fleet (note: a distribution for the diesel fleet could not be included here, and the variability for the hybrid CNG fleet is due to the limited number of fueling records).

Figure 47. Distance Between Fueling Events for All Conventional Trucks, Fleet 4

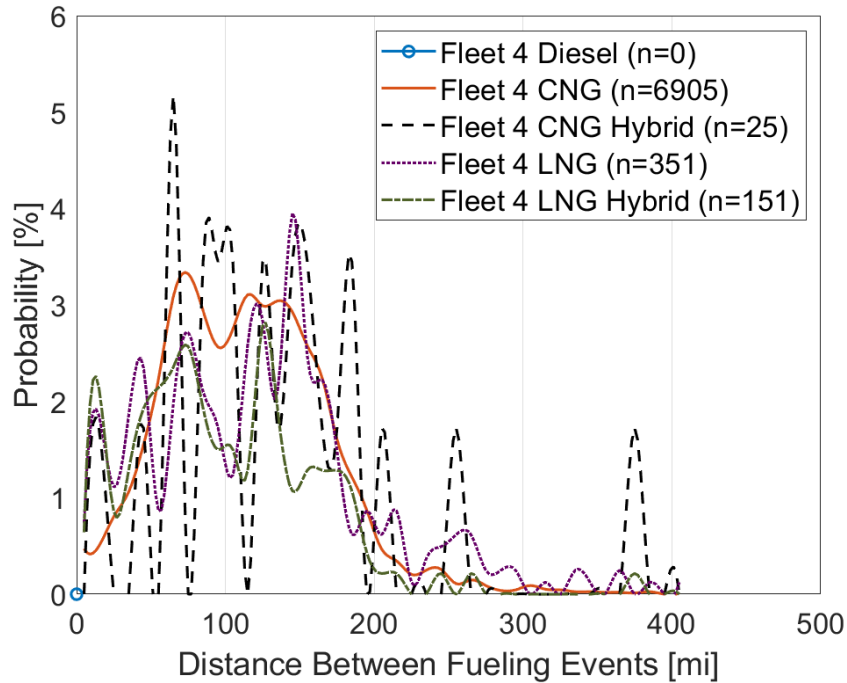
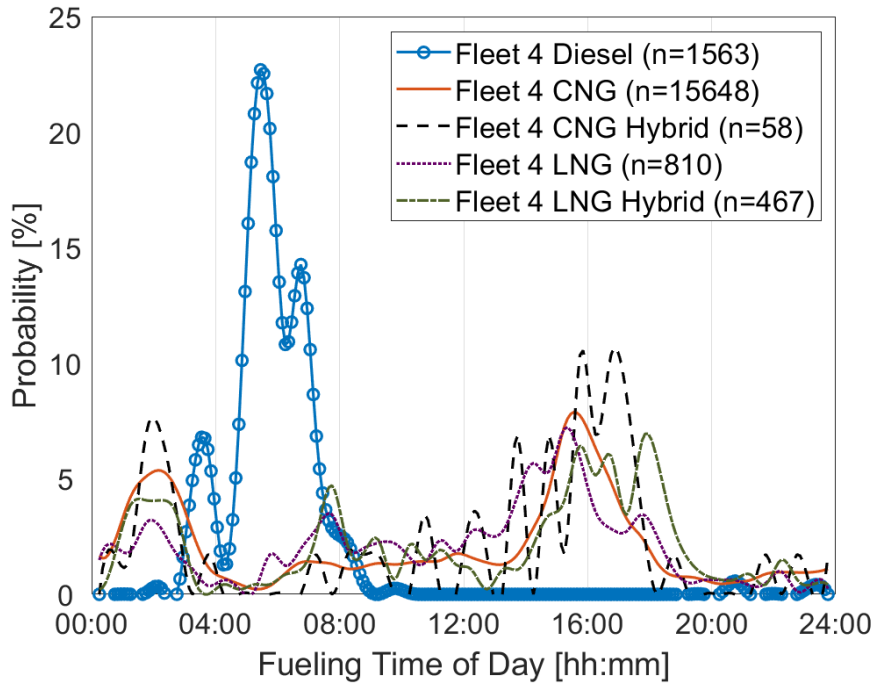

Figure 48 shows the distribution of fueling time of day for all conventional vehicle types. The diesel fleet shows a distinct peak between 5:00–7:00 a.m., while all other types (CNG and LNG) tend to refuel beginning in the midafternoon. This fueling behavior may be influenced by the relatively quick and easy fueling provided by diesel fuel compared to natural gas refueling, but may also be a result of the specific fueling stations/operations used by this fleet operator.

Figure 48. Fueling Time of Day for All Conventional Trucks, Fleet 4



3.3 Ocean Trucks

The Ocean Class 8 tractor FCEV data were logged by Kenworth and provided to NREL throughout the performance period for analysis. The operational data were collected for the 10 Ocean trucks between July 2021 and August 2022. Of the nearly 60,000 Ocean truck miles reported by Kenworth, 21,650 miles of in-service data were collected during this period from 431 operational days for the fuel cell trucks.

Error! Not a valid bookmark self-reference. 3 shows individual data collection metrics for each of the 10 Ocean trucks in the data collection period. Although most nonoperational days were directly excluded from the analysis, instances where a truck was out of service due to a lack of available operators or other unplanned reasons created the possibility of nonoperational data being captured but not flagged as nonoperational. To account for this possibility, days where less than 0.5 miles of driving occurred were also excluded from this analysis. As such, both the total number of days where data were collected and the number remaining after excluding days with insufficient driving are given. The additional metrics of logger hours and miles of data are reported only after this exclusion was implemented.

Table 3. Individual Ocean Truck Data Collection Summary Metrics

Ocean Truck Number	Start-Service Date (2021)	End-Service Date (2022)	In-Service Days (All Days)	In-Service Days (>0.5 miles Travel)	In-Service Logger Hours (>0.5 miles Travel)	In-Service Data Miles Driven (>0.5 miles Travel)
1	7-Jul	31-Jan	49	43	126.5	1,925.3
2	15-Jul	31-Jan	53	42	108	2,180.1
3	8-Jun	1-Aug	119	103	277.8	5,418
4	12-May	22-Jan	47	42	174.8	2,709.3
5	23-Jul	31-Jan	43	43	84.1	1,657.8
6	29-Oct	31-Jan	18	18	137.6	1,467.9
7	29-Oct	31-Jan	28	28	236.2	1,862.3
8	29-Oct	31-Jan	39	37	204.1	1,681.8
9	29-Oct	5-Aug	33	33	75.4	1,238.5
10	29-Oct	5-Aug	46	42	126.7	1,508.6
Total	-	-	475	431	1,551.2	21,649.7

Error! Not a valid bookmark self-reference.3 shows that each of the 10 trucks reported over 1,200 miles of operational data, with Ocean 3 providing over 5,400 miles of operation logged. The mileages reported in this table differ from those shown in Figure 21 because these values are only describing the miles driven during the intended operation of the trucks that occurred within the respective data collection periods for each truck. The mileage totals given in Figure 21 describe all miles driven by the trucks across 2020, 2021, and 2022 including nonoperational miles and operation occurring outside of these data collection periods.

Error! Not a valid bookmark self-reference.49 shows the relative variations in daily energy intensity and fuel consumption of the combined fleets over the data collection period.

Figure 49. Daily Energy Intensity and Fuel Consumption of Ocean Trucks

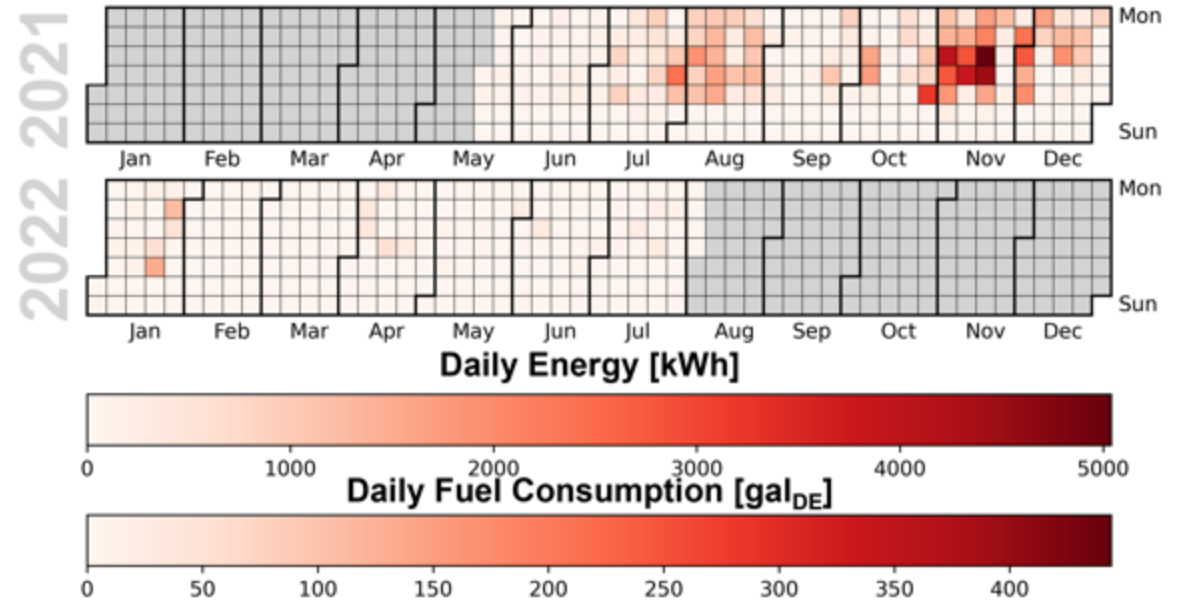

The fuel and energy data shown here indicate that typical operation for these trucks was limited to weekdays. Additionally, while the total energy and fuel use increased with the number of trucks in service initially, these values decreased in September due to all five Ocean trucks in operation at that time spending at least part of the month out of service. The greatest fuel and energy intensity occurred in November 2021 when all 10 trucks were in operation. This intensity then begins to decrease again in December as the first trucks begin to reach the end of their respective data collection period. Seven of the Ocean trucks ended their service by the beginning of February. The three remaining trucks completed their service period by August 5, 2022.

An average daily distance of approximately 50 miles and a daily average fuel economy of 6.7 miles per diesel gallon equivalent (MPG_{DE}) was observed in this collection period for all 10 trucks. MPG_{DE} is described as the energy consumed per mile by the vehicles normalized to the average energy content of a gallon of diesel fuel. Table 4 gives various operational characteristics and data logging metrics for each of the fleets. The stack energy described in Table 5 refers to the net output energy of the electric traction motor—i.e., the total energy produced by the fuel cell stack minus transmission losses and auxiliary loads.

Where daily average values are presented in this report, it is important to note that each operational day carries the same weight regardless of how much the vehicle was used that day. Therefore, nonoperational data or atypical values produced by days with especially short driving distances are capable of having a disproportionate impact on the daily average values. To provide a more complete characterization of the vehicles and account for the possibility that some nonoperational days may still remain in the data, distance-weighted fuel economy metrics are provided in Table .

Table 4. Data Collection Summary – Ocean Vehicles

Description	Fleet 1	Fleet 2	Fleet 3	Fleet 4
Number of FCEVs Logged	4	3	1	2
Vehicle Type	Drayage	Drayage	Drayage	Drayage
Total Miles Logged	11,181	1,551	2,709	3,544
Number of Active Days Logged	231	93	42	65
Avg. Daily Moving Speed [mph]	31.3	20.3	25.8	18.1
Avg. Daily Distance [mi]	48	45	65	55
Max Daily Distance [mi]	121	83	83	82
Average Miles per Gallon _{DE}	6.1	8.2	6.9	6.7
Average Fuel Use [kg _{H2} /mi]	0.187	0.150	0.172	0.175
Avg. Daily Engine Run Time [h]	2.5	3.5	4.1	6.7
Avg. Daily % Idle	44.0	37.3	38.4	54.7
Stack Energy [kWh]	94.8	67.2	112.3	82.8

Based on the assumption that any remaining nonoperational days contain relatively small amounts of travel, the distance-weighted metrics are expected to be less sensitive to erroneous values that may be introduced. Over the test period, the daily average and distance-weighted metrics did converge to the relatively close values seen in Table 4 and Table 5, providing support to the assumption that any remaining nonoperational days are small enough to have limited impacts on the final results.

Table 5. Distance-Weighted Fuel Economy Metrics*

Description	Fleet 1	Fleet 2	Fleet 3	Fleet 4
Distance-Weighted Average Fuel Economy [Miles/Gal _{DE}]	6.3	8.1	7.0	6.8
Distance-Weighted Average Fuel Use [kg _{H2} /mile]	0.183	0.150	0.167	0.169

*Toyota notes that the Ocean trucks utilize the first-generation Toyota Mirai system and were built to understand customer utilization/experience, and not for fuel cell system efficiency or performance. Consequently, the fuel economy was expected to be low and not representative of the future production configurations. Next-generation fuel economy is expected to meet or exceed the fuel economy improvement from the first-generation Toyota Mirai to the second-generation Toyota Mirai (~12.3%), as shown in Toyota’s internal fuel economy tests.

3.3.1 Ocean Trucks Duty Cycle

Distributions of the daily average driving speed and daily distance separated by fleet are shown in Figure 50. Similar to the baseline vehicles, Fleet 1 had the highest daily average speed just over 30 mph, while Fleet 3, Fleet 2, and Fleet 4 showed daily average speeds of 26 mph, 20 mph, and 18 mph, respectively. Each of these speeds reflect the primarily urban operation of these drayage trucks. As the Ocean trucks were used as a demonstration of first-generation FCEV technology, the operation of these vehicles was restricted to a smaller delivery radius than the baseline vehicles.

Figure 50. Distribution of Daily Average Speed (left) and Daily Distance (right)

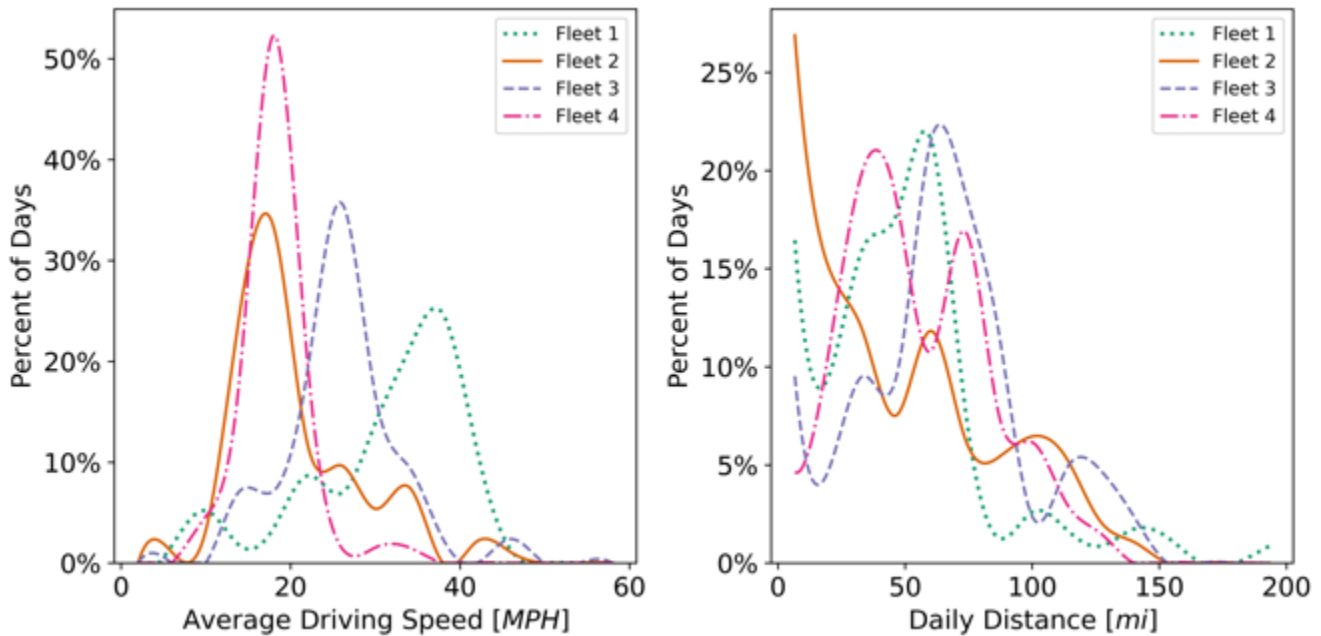

Average daily distance for the Ocean trucks ranged from 45 mi (Fleet 2) to 65 mi (Fleet 3), well below the average distances of the baseline vehicles. However, a maximum daily distance of 195 miles was reported for Fleet 1, and a maximum between 132 and 134 miles was reported for the remaining fleets. These higher-mileage days indicate that although these vehicles were primarily used for operations with lower driving requirements than the baseline vehicles, they are capable of driving significantly greater distances than what they saw on average.

Looking at the fuel economy of these advanced technology vehicles gives further insights into their operational characteristics and performance in comparison to the baseline vehicles. Figure 51 describes the daily average fuel economy of the Ocean trucks in their respective fleets on a fuel economy (MPG_{DE}) basis. This conversion allows for a more direct comparison of the fuel economy of these FCEV trucks to the baseline vehicles.

Figure 51. Distribution of Fuel Economy (left) and Fuel Rate (right)

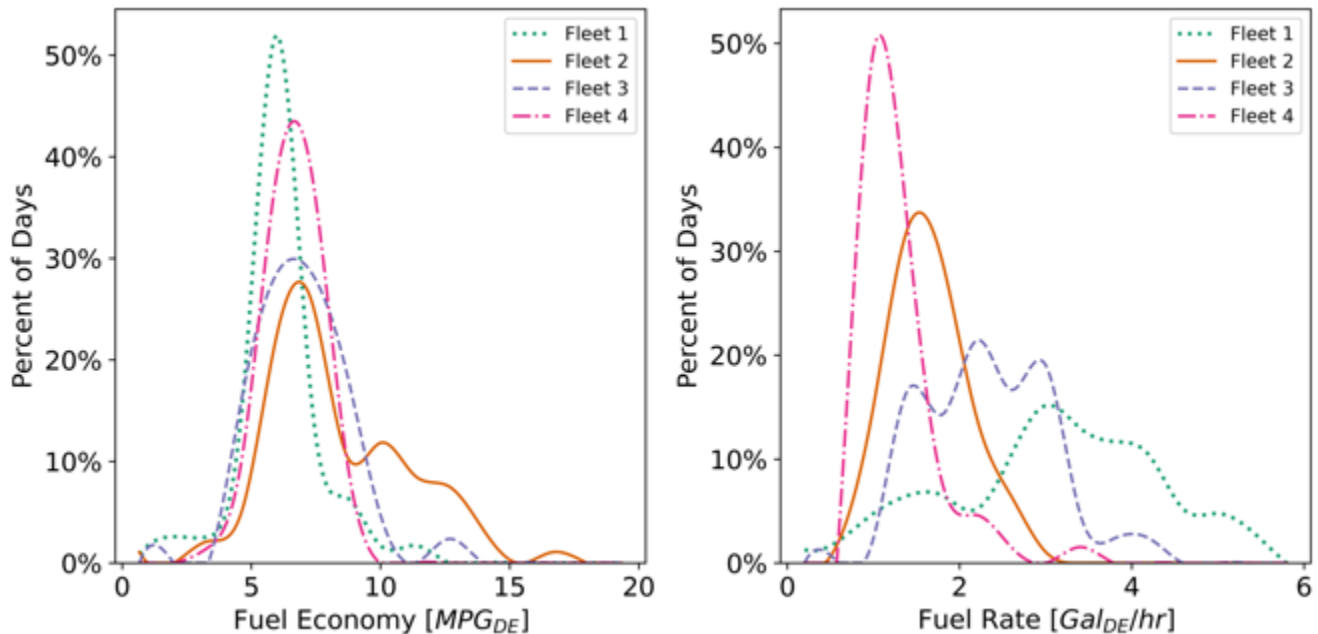

All of the fleets except Fleet 2 showed relatively small deviations in their daily fuel economies across all of the days. Most of the daily fuel economy values for each of these fleets are tightly grouped near their respective total average, which ranged from approximately 6 to 7 MPG_{DE} . Meanwhile, Fleet 2 exhibited a total daily average fuel economy slightly over 8 MPG_{DE} with a larger standard deviation of the daily values. This difference is likely due to greater variation in the daily payloads for the Fleet 2 trucks compared to the other fleets, the low idle fraction of Fleet 2 compared to the others, and other differences in the duty cycle of these trucks.

The FCEVs in all of the fleets exhibited similar or better fuel economy than their baseline counterparts. This performance occurred despite the fact that the Ocean trucks operated more predominantly on urban roadways and off highways compared to the baseline vehicles. This improvement indicates some of the advantages of this advanced technology on more congested, lower-speed roadways, but it is important to note that other factors, such as differences in payload weight, can have a significant impact on the fuel economy of these vehicles.

The distributions of fuel rates for the fleets are indicative of the differences in the duty cycles of the vehicles in each fleet. Operation of Fleet 4's vehicles led to the lowest average rate of fuel consumption, 1.3 $\text{gal}_{\text{DE}}/\text{hr}$. This low rate of consumption suggests these vehicles tended to operate at a lower energetic intensity on average, partly due to a larger portion of their operational hours being spent at idle where fuel consumption rates are relatively low. While the variation in the daily fuel rates of Fleet 1 was more significant than that of the other fleets, the total average fuel rate was 3 $\text{gal}_{\text{DE}}/\text{hr}$, indicating that these vehicles had considerably greater energy intensity for their operation.

Further understanding of the operational needs and energy usage of Ocean trucks comes from inspection of the engine run time and idle fractions of the fleets, shown in Figure.

Figure 52. Distribution of Daily Run Time (left) and Percent Idle (right)

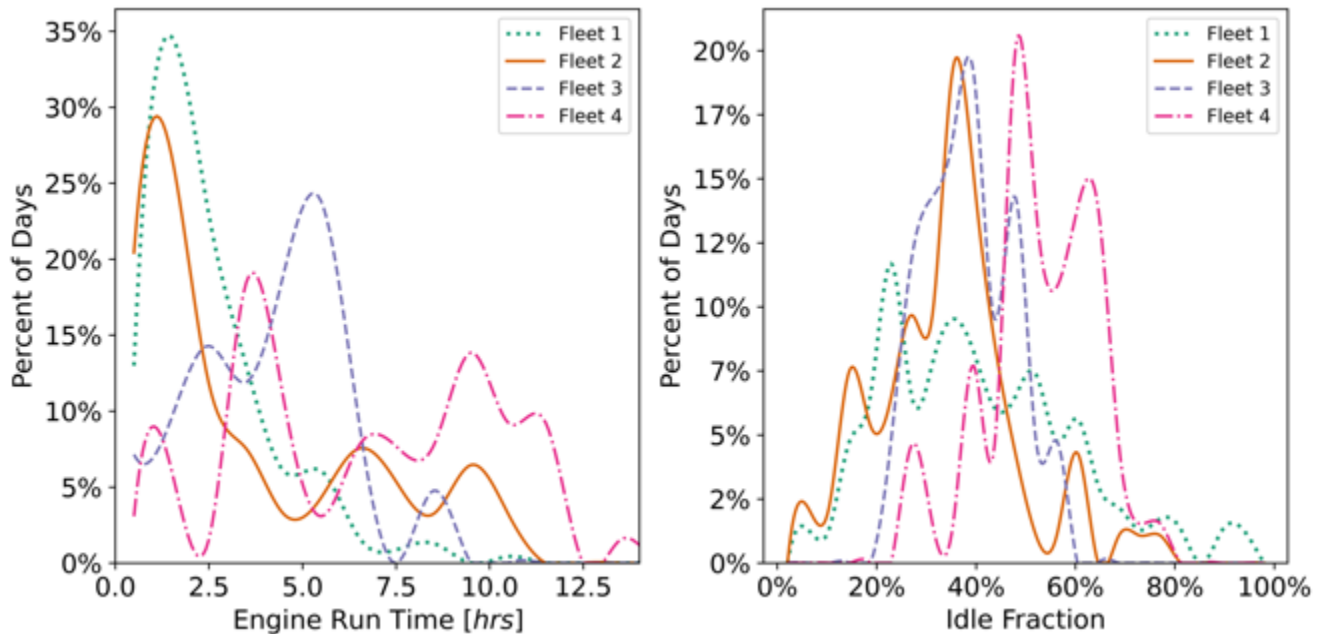

Average daily run time of the FCEVs was significantly lower than that of the conventional vehicles, ranging from 2.5 to 6.7 hours compared to 5.5 to 10.0 hours for the baseline vehicles. Furthermore, Ocean trucks spent a larger portion of their engine-on time at idle. For this advanced technology there is no requirement to keep an engine running while at idle, as all auxiliary components are powered directly by the battery. Additionally, these zero-emission vehicles have no direct negative impact on the local air quality when idling for extended periods, whether the fuel cell stack is running or not. However, explicit values for the portion of energy expended while idling cannot be determined due to the lack of data describing the power into and out of the high-voltage battery.

The higher idle fraction of the Ocean trucks is expected when considering the smaller portion of highway driving seen by these trucks compared to the baseline vehicles. A larger portion of the operational time is likely spent loading and unloading the Ocean trucks due to their shorter delivery routes. As described previously, the low rate of fuel consumption for Fleet 4 is explained in part by the high idle fraction of this fleet. These vehicles had an average idle fraction of 53%, while the other fleets had idle fractions between 34% and 40%.

Figure 53 shows the total daily stack energy produced or net tractive energy of the vehicle by the Ocean trucks, as well as fuel use on the basis of mass of hydrogen consumed per mile. These vehicles are able to utilize regenerative braking, allowing them to recapture energy normally lost to friction braking in a conventional vehicle.

Figure 53. Distribution of Stack Energy (left) and Daily Average Fuel Economy (right)

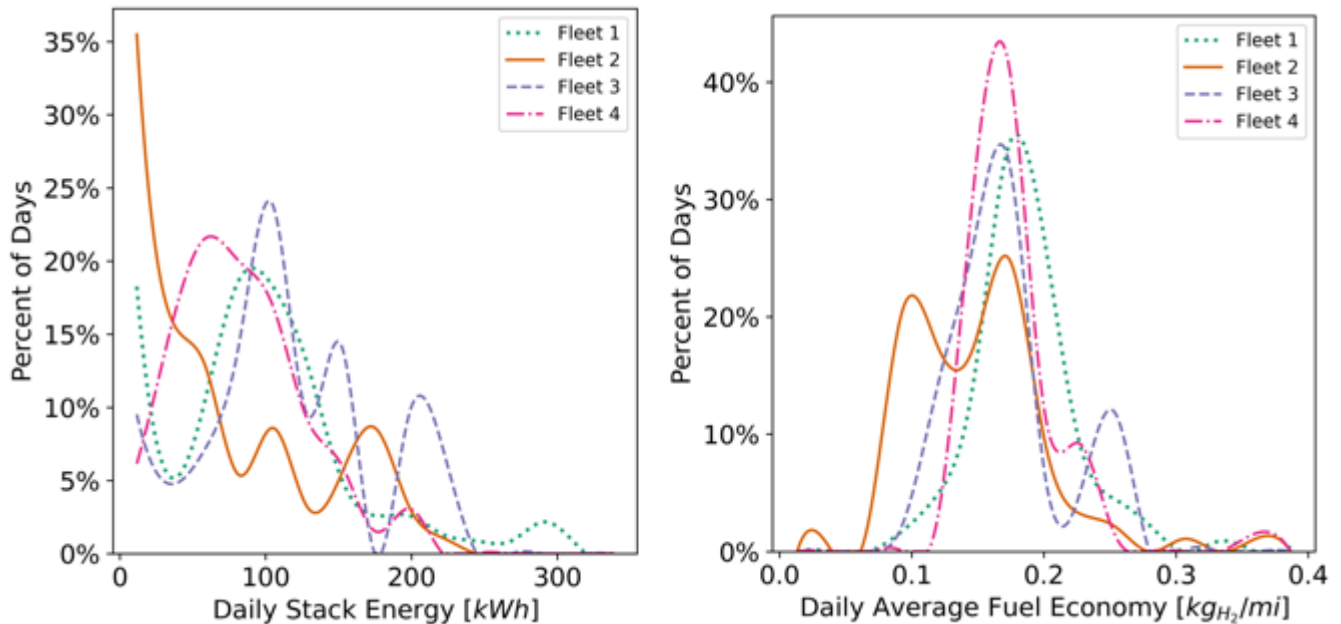

The daily stack energy expended by the Ocean trucks varied from 67 kWh for Fleet 2 to 112 kWh for the Fleet 3 truck. While these average values are far lower than the typical range of flywheel energy requirements in the baseline vehicles, the maximum values show greater overlap with the typical ranges observed in the baseline fleets. Fleet 1 showed a maximum daily net brake energy of 403 kWh, well into the range seen by the baseline vehicles. The other three fleets showed maximum values between 209 and 230 kWh. However, these differences are not strictly due to differences in the capabilities of the FCEVs. The operational characteristics of the Ocean trucks are shown to involve significantly shorter daily distances, leading to lower daily energy consumption. Additionally, the energy consumed during idling of the advanced vehicles can be presumed to be significantly less than that consumed by the conventional vehicles, as previously described. Lastly, the use of regenerative braking in these electric vehicles allows some of the energy expended to be recaptured, leading to a reduction in the stack energy expended.

3.3.2 Ocean Truck Maintenance

Toyota provided NREL with a summary of maintenance activities performed on the Ocean trucks during the operational period. The starting and ending dates of the service period were defined for each truck, as displayed in Figure 5454.

For each truck, every maintenance activity included a description, labor hours, and associated cost. All the costs were categorized as scheduled or unscheduled costs (Figures 55 and 56), parts or labor costs, whether or not they related to the fuel cell system, and whether the costs

were (a) common to a production truck, (b) a prototype truck component, or (c) R&D/innovation specific to this project (Figure 57).

Figure 54. Ocean Truck Maintenance Timeline

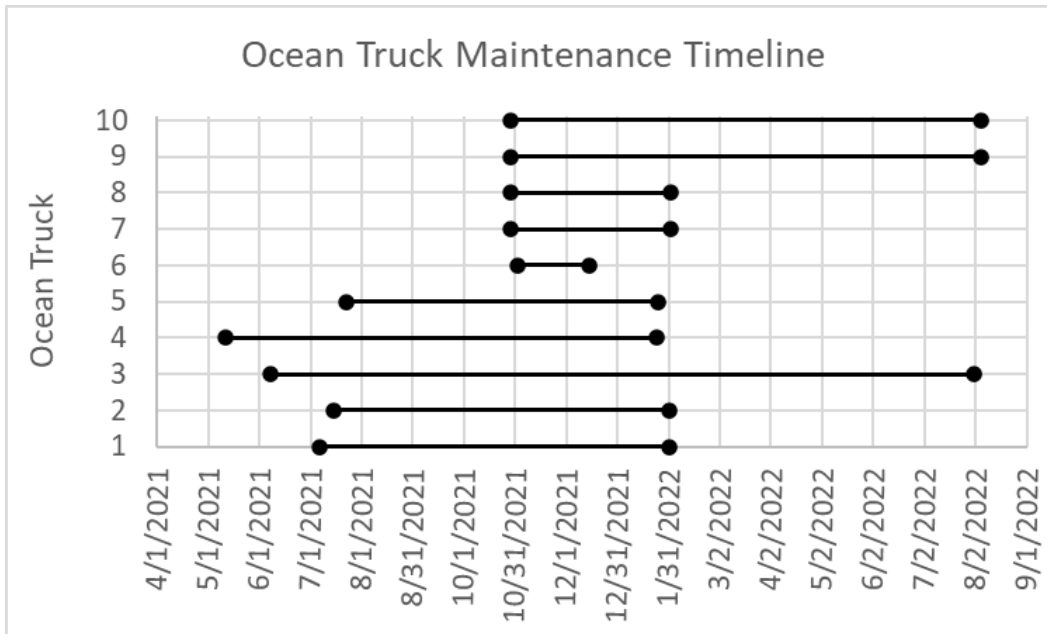

Figure 55 shows the total repair cost for each Ocean truck during the demonstration period, separated by scheduled and unscheduled maintenance activities. The corresponding pie chart in Figure 56 shows the total combined repair costs for the Ocean truck fleet, comparing unscheduled to scheduled maintenance costs. Approximately 72% of the costs during this period were due to unscheduled maintenance activities, which are not indicative of costs associated with production level trucks as these activities are due to prototype components and R&D investigation activities. Similarly, Figure 57 shows the total maintenance cost for each Ocean truck separated by the three specified categories indicating the technology level for each vehicle part or system being repaired during this demonstration. The combined totals for the Ocean fleet shown in Figure 58 reveal that approximately 45% of the repair costs were deemed prototype component costs, 35% were R&D/innovation costs, and the remaining 20% of costs were repairs that were similar to those needed for a production vehicle.

Figure 55. Scheduled and Unscheduled Maintenance Costs for Each Ocean Truck

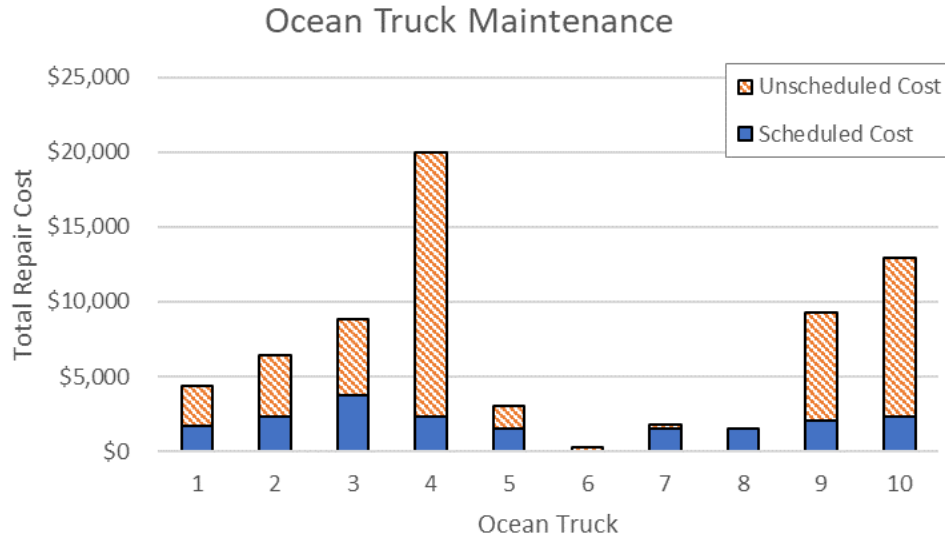

Figure 56. Scheduled and Unscheduled Maintenance Costs for the Ocean Truck Fleet

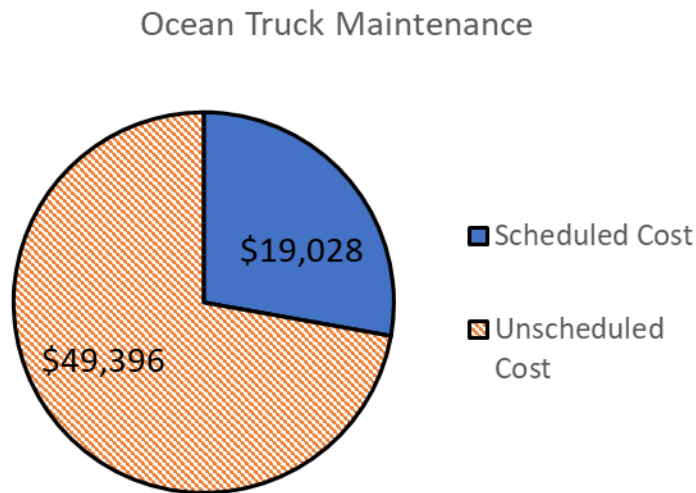

Figure 57. Maintenance Costs by Category for Each Truck

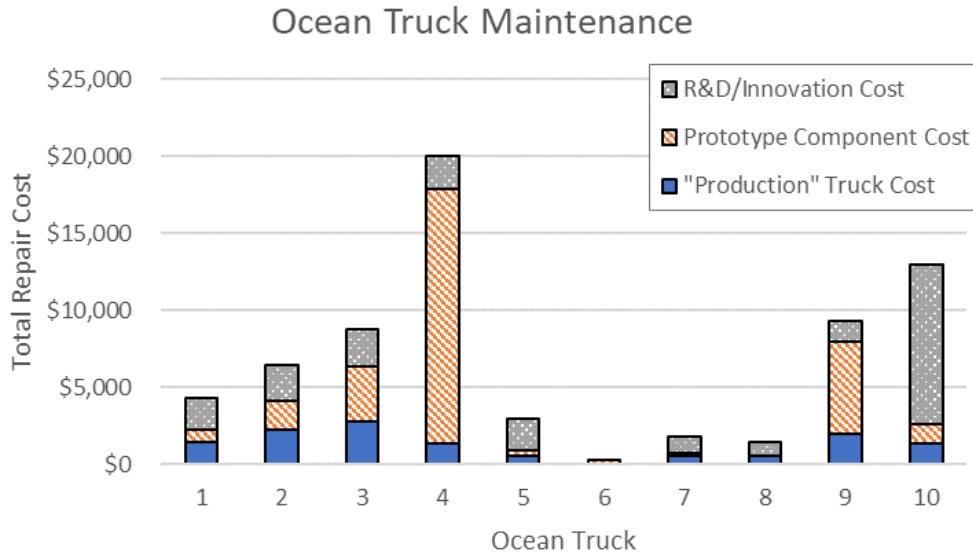
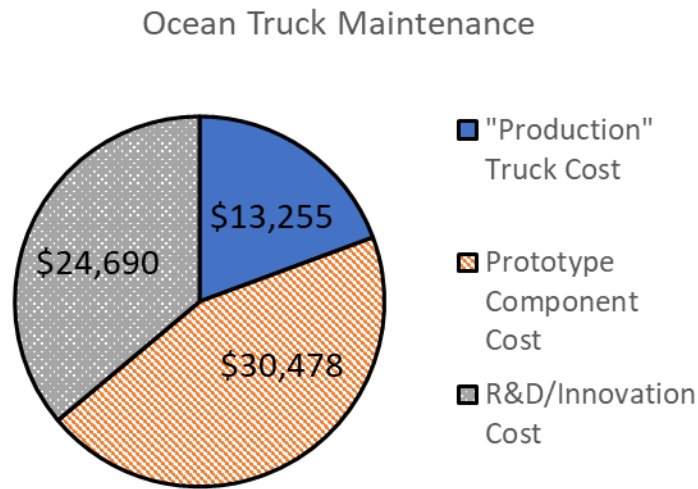

Figure 58. Maintenance Costs by Category for the Ocean Truck Fleet



3.3.3 In-Use Demonstration Experience (i.e., Operator Surveys)

Surveys were provided to the drivers of the Ocean trucks after 30 and 90 days in service. For the 30-day surveys, 9 of 10 were returned, and for the 90-day surveys, 10 of 10 were returned. These responses, summarized in Figure and shown in full in Figure 6060, show that the Ocean trucks were generally well received, and the median responses tend to be the same or better for most categories except for fueling-related activities and driving range being rated worse. However, as with many surveys of this type, some responses for objectively measurable things like range, fueling time, and acceleration can span the full range of options

(from much worse to much better), making conclusions on specific questions limited. Written comments on the survey forms added some additional information/context. Comments stated that the Ocean trucks could use a better transmission; more fueling stations were needed, as the one they had was often down or had a 2-hour wait; and the hazard lights did not keep working when the system broke down (this was repaired as soon as this fault was communicated to the engineering team). These types of issues are expected with prototype demonstrations and provide helpful feedback as improvements are made for future production vehicles.

Figure 59. 30-Day and 90-Day Ocean Truck Survey Responses Compared

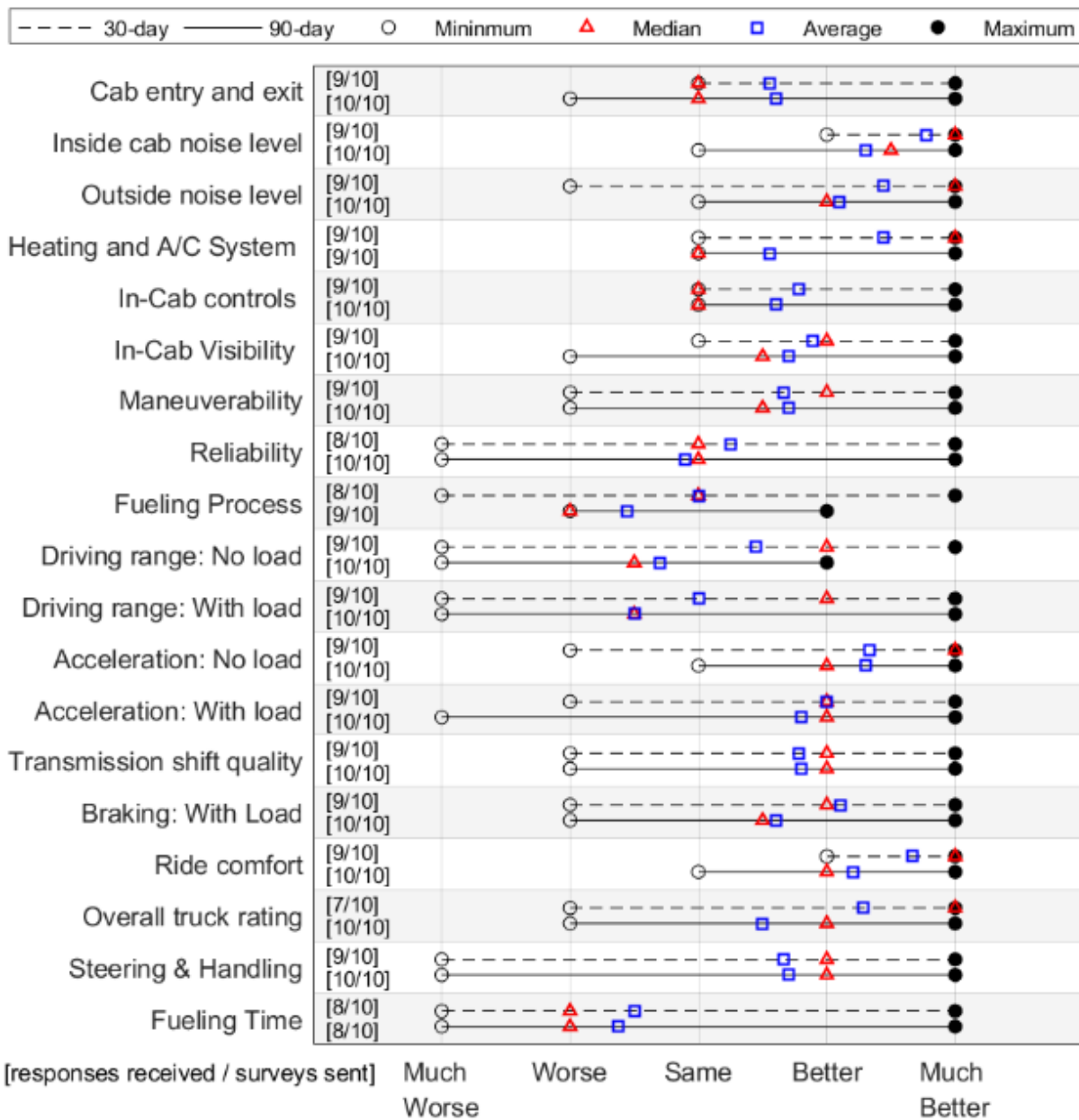

Figure 60. 30-Day and 90-Day Ocean Truck Detailed Survey Responses

How does the hydrogen fuel cell electric truck compare to a Diesel truck? (check one)	Survey	Much Worse	Worse	Same	Better	Much Better
Cab entry and exit	30 Day	0	0	6	1	2
	90 Day	0	1	5	1	3
Inside cab noise level	30 Day	0	0	0	2	7
	90 Day	0	0	2	3	5
Outside noise level	30 Day	0	1	0	2	6
	90 Day	0	0	2	5	3
Heating and A/C System	30 Day	0	0	2	1	6
	90 Day	0	0	6	1	2
In-Cab controls	30 Day	0	0	5	1	3
	90 Day	0	0	6	2	2
In-Cab Visibility	30 Day	0	0	4	2	3
	90 Day	0	1	4	2	3
Maneuverability	30 Day	0	1	3	3	2
	90 Day	0	1	4	2	3
Reliability	30 Day	1	2	2	0	3
	90 Day	1	3	3	2	1
Fueling Process	30 Day	1	2	3	0	2
	90 Day	0	6	2	1	0
Driving range: No load	30 Day	1	1	2	3	2
	90 Day	1	4	2	3	0
Driving range: With load	30 Day	3	1	0	3	2
	90 Day	3	2	3	1	1
Acceleration: No load	30 Day	0	1	1	1	6
	90 Day	0	0	1	5	4
Acceleration: With load	30 Day	0	1	1	4	3
	90 Day	1	0	1	6	2
Transmission shift quality	30 Day	0	1	3	2	3
	90 Day	0	1	3	3	3
Braking: With Load	30 Day	0	1	1	3	4
	90 Day	0	1	4	3	2
Ride comfort	30 Day	0	0	0	3	6
	90 Day	0	0	1	6	3
Overall truck rating	30 Day	0	1	0	2	4
	90 Day	0	3	1	4	2
Steering & Handling	30 Day	1	0	3	2	3
	90 Day	1	0	3	3	3
Fueling Time	30 Day	2	3	1	1	1
	90 Day	1	5	1	0	1

3.3.4 Discussion of Baseline and Advanced Vehicles

This section explores the comparison between the baseline conventional test vehicles, which consisted of diesel and CNG internal combustion engine-equipped vehicles, and the advanced hydrogen fuel cell vehicles tested in this project. Daily average speed and daily distance traveled are two key parameters for examining vehicle duty cycle. The CNG and H₂ vehicles had similar daily average driving speed distributions, as shown on the left in Figure 61, with average daily driving speeds around 25 mph. The diesel vehicles had slightly higher speed distributions with an average speed around 35 mph. These speeds are indicative of the operation of the vehicle, with the CNG and H₂ vehicles operating in slower-speed service. This is likely a result of these vehicles staying closer to the ports and fueling stations near the port, which are more densely populated and have more traffic. However, these speeds only had a slight impact on the daily distance of the vehicles, with the CNG and diesel vehicles having 172 mi and 212 mi average daily distances, respectively. It is important to understand that these differences exist in the real-world operation because they may have impact on the efficiency numbers. Highway speeds may expend more energy to overcome aerodynamic drag, whereas the slower speeds may indicate more idling and stop-and-go traffic, which can lead to higher energy use. The average daily distance for the H₂ vehicle was 50 miles, with a maximum distance of 194 miles. This distance is lower due to the range constraints on the vehicle, as well as the limited operation for this testing since available public infrastructure is limited.

Figure 61. Average Driving Speed and Daily Distance

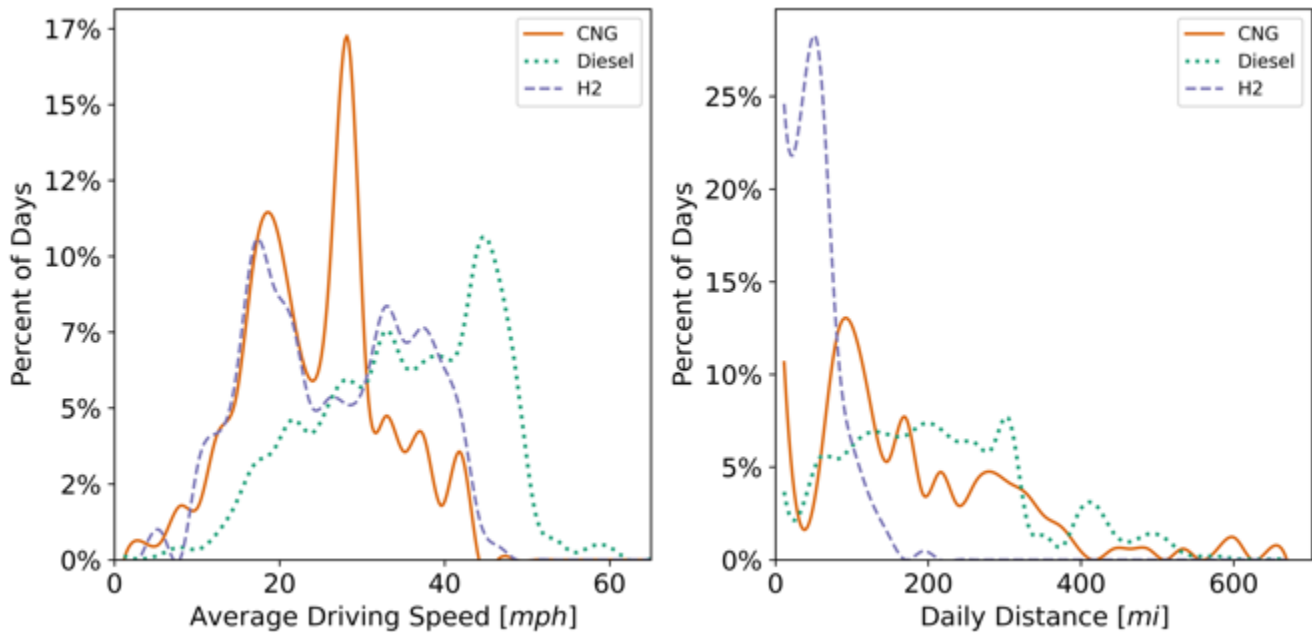

Engine run time and percent of time at idle are also key metrics to understanding vehicle duty cycle. Figure 62 shows the distribution of daily run time (left) and the percentage of operation at idle (right), which is defined as vehicle on and speed equal to zero. Drayage operation consists of frequent operation where the vehicle is stopped waiting to pick up a container, and

this can have an impact on fuel economy. Reduction of energy use at idle is another key benefit for electrified powertrains such as the H₂ vehicles studied here. The baseline vehicles had average daily engine run time of 7.7 hours, with around 23% of that spent at zero speed or idle as defined in the report. The H₂-powered vehicle had about half of the run time at 3.6 hours per day on average, with an average idle fraction around 40%. Despite the higher idle fraction, this is a time when the vehicle is consuming very little energy compared to the conventional powertrains.

Figure 62. Distribution of Engine Run Time and Idle Fraction (speed = 0, vehicle on)

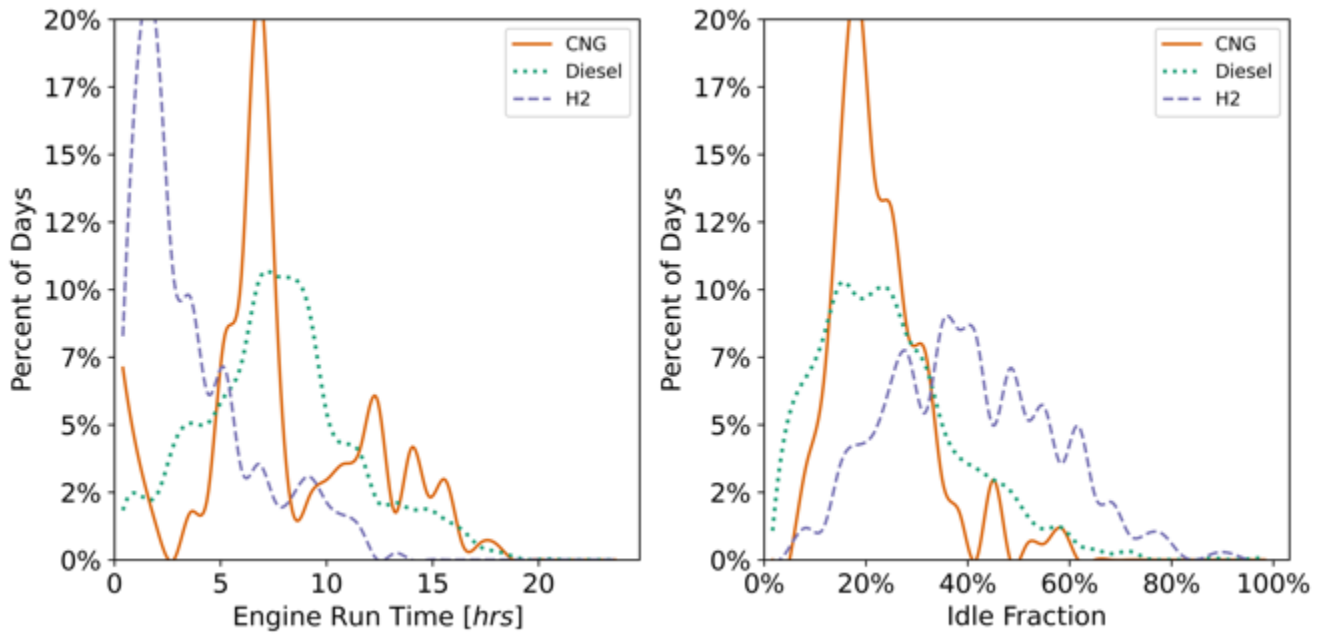

To understand how this impacts the vehicle's energy efficiency, Figure 63 shows the MPG_{DE} , with the CNG vehicle having an average of 4.7 MPG_{DE} , diesel at 6.4 MPG_{DE} , and H₂ at 6.7 MPG_{DE} . For fuel rate, the CNG vehicles consumed 4.0 gal_{DE}/hr, diesel vehicles consumed 4.4 gal_{DE}/hr, and the H₂ vehicles were at 2.4 gal_{DE}/hr on average. This shows that, on average, the H₂ vehicle had the highest efficiency of the three powertrain types and the lowest fuel rate.

Figure 63. Distribution of Fuel Economy and Fuel Rate

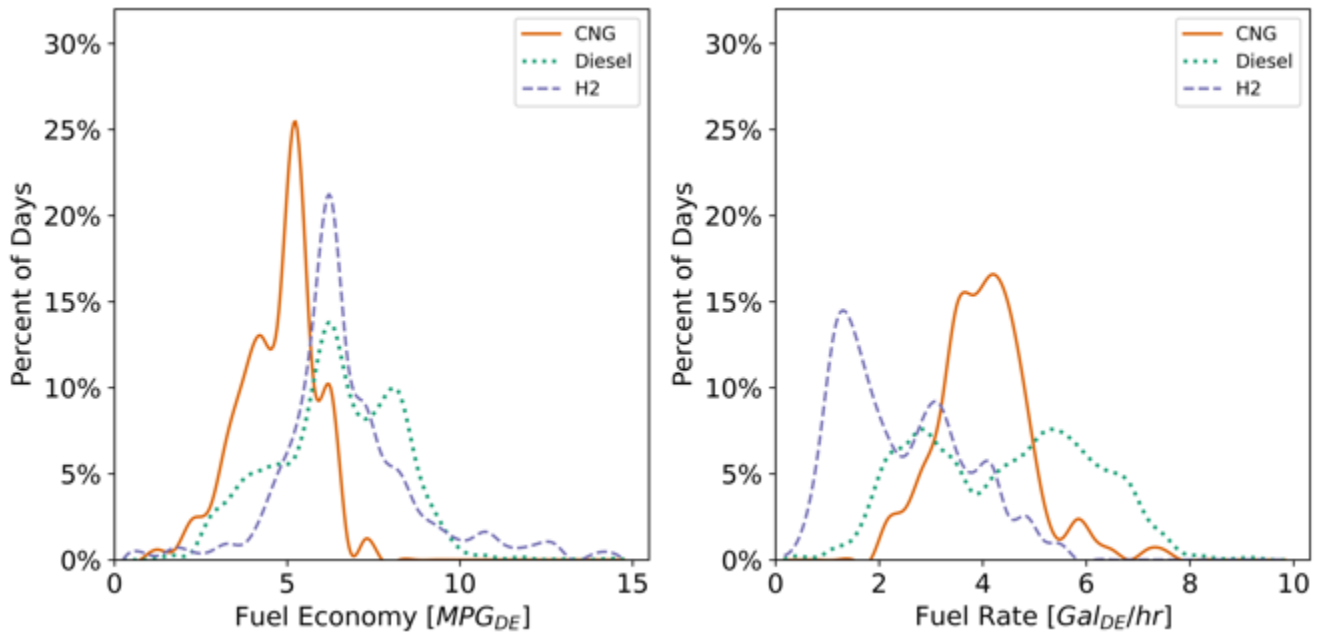

Engine-produced flywheel energy provides insight into the tractive energy requirements of each vehicle. This is the total energy in kilowatt-hours produced by the engine at the flywheel, so this would be after the thermal efficiency losses within the engine. While these numbers are not measured, they are estimated by the vehicle. The H₂ vehicles do not have an engine, so this number refers to the energy going to the propulsion of the vehicle. The left plot of Figure 64 shows the distributions of the daily flywheel energy for each powertrain type, along with the energy consumption per mile, to understand the total energy use during the testing. As expected, the H₂ vehicle had lower overall propulsion energy with an average daily energy of 98 kWh compared to 362 kWh for the CNG and 548 kWh for the diesel. This is due to a combination of lower daily distances, efficiency improvements, and other uncategorized differences in duty cycles. To help normalize these to the operation, the right plot in Figure 64 shows the per-mile energy consumption rate in kWh/mi. The diesel-powered vehicles had the highest energy rate at 2.5 kWh/mi, followed by CNG at 2.1 kWh/mi. The H₂ powertrain had the lowest average energy consumption at 1.8 kWh/mi, which is likely a result of the differences in operation and efficiency improvements from regenerative braking. While the TLS operation showed slightly lower payloads due to trailer configuration restraints for moving vehicles, this packaging constraint did not exist for the other operations hauling trailers, but no information is available on the exact payloads of the other operations.

Figure 64. Distribution of Flywheel Energy and Energy Consumption Rate

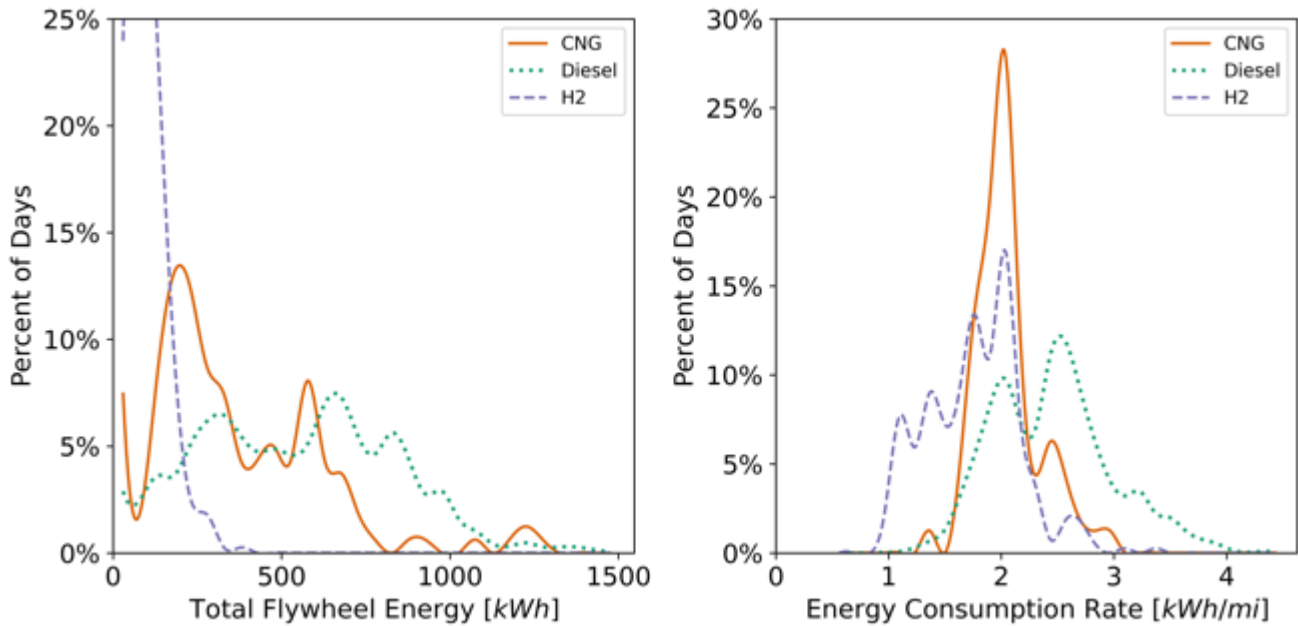

CO₂ is a key contributor to climate change and a byproduct of the combustion process for internal combustion engine vehicles, including the baseline CNG and diesel vehicles in this study. In addition, NO_x and SO_x are criteria pollutants produced by combustion of specific fuels and can be detrimental to human health. Greenhouse gases and criteria pollutants are key emission categories that advanced, zero-emission technologies such as hydrogen-powered vehicles seek to reduce by having zero tailpipe emissions other than water. However, when looking at emissions reduction, it is important to also consider the emissions from producing the fuel or energy source, as these can be significant. Figure 65 shows the tailpipe emissions and emissions from producing the energy source (production emissions) as modeled using the Greenhouse gases, Regulated Emissions, and Energy use in Technologies (GREET) model for each propulsion type, which includes the CO₂e, NO_x, and SO_x.

As expected, the hydrogen has zero tailpipe emissions; however, there are still emissions from producing the energy for each fuel. The typical hydrogen produced in the United States is labeled "H₂" in Figure 65 and has 15% lower CO₂e emissions than the total diesel and CNG emissions, but with increases in NO_x and SO_x compared to the diesel. This is a result of having steam methane reforming of natural gas as the primary source for hydrogen production. This project team opted to use hydrogen produced from steam methane reforming of diverted methane emissions from dairy and swine manure, which provides a reduction of CO₂e. Using reduction numbers provided by Shell in Section 2.2.1 Renewable Hydrogen and Environmental Impact and production numbers from the Alternative Fuel Lookup Table for the Compressed

Hydrogen pathway produced in California² from central steam methane reforming of biomethane, the columns labeled H₂ZANZEFF show the net negative CO₂e as well as decreased total criteria pollutants by 15.5 kg NO_x (0.163 g/km), 1.01 kg SO_x (0.0106 g/km), and 304.8 metric tonnes of CO₂e (3.2 kg/km). It should be noted that these emission profiles are based on the observed duty cycles and model years of vehicles.

Figure 65. Tailpipe and Production Emissions for CNG, Diesel, and H₂ Vehicles
Class 8 Tractor Real-World Emissions

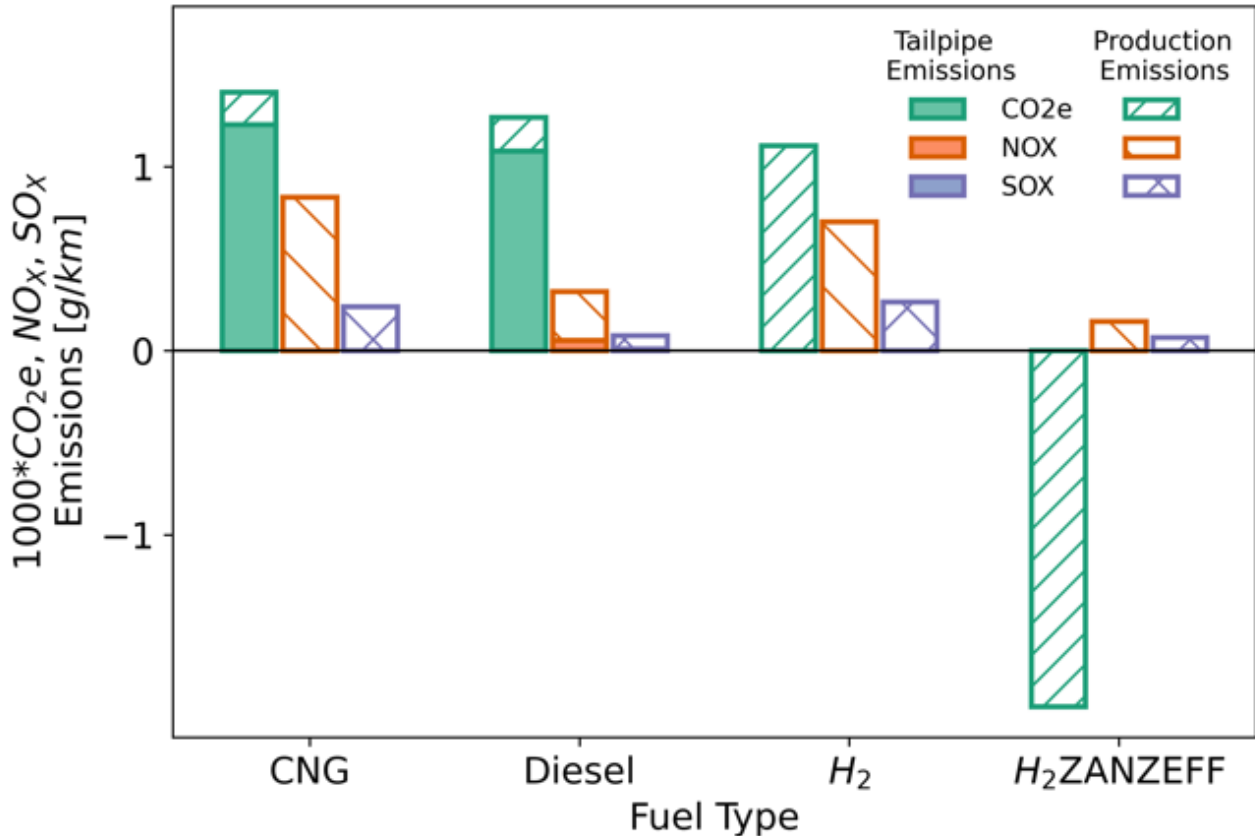

3.4 Hydrogen Stations

NREL received hydrogen fueling data from Shell on a quarterly basis throughout the demonstration. The data included individual fueling records for the Ontario and POLB stations spanning just over 1 year of operation, as well as monthly summaries of total fuel dispensed and total energy consumption from the electric utility for 10 months of operation. Hydrogen fueling data for the Wilmington station were not available for this analysis.

² <https://ww2.arb.ca.gov/sites/default/files/classic/fuels/lcfs/ca-greet/lut-doc.pdf>

3.4.1 Station Energy Consumption and Fuel Dispensed

The monthly data summaries for the hydrogen stations included total electricity consumption and total cost for POLB and Ontario stations, per the electric utility billing periods. The average electricity cost paid by the stations was calculated for each month (Figure 66). The monthly cost for the POLB station varied from a low of \$0.38/kWh to a high of \$0.67/kWh, with an annual average of \$0.48/kWh. The Ontario station monthly cost varied between \$0.17/kWh and \$0.48/kWh, averaging \$0.35/kWh for the 10-month period.

Figure 66. Monthly Hydrogen Station Electricity Cost

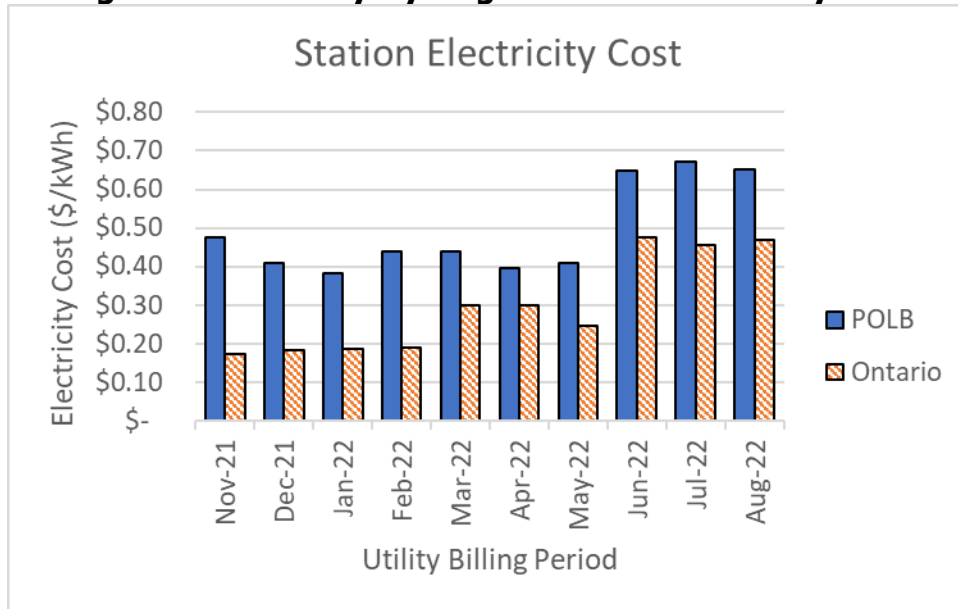
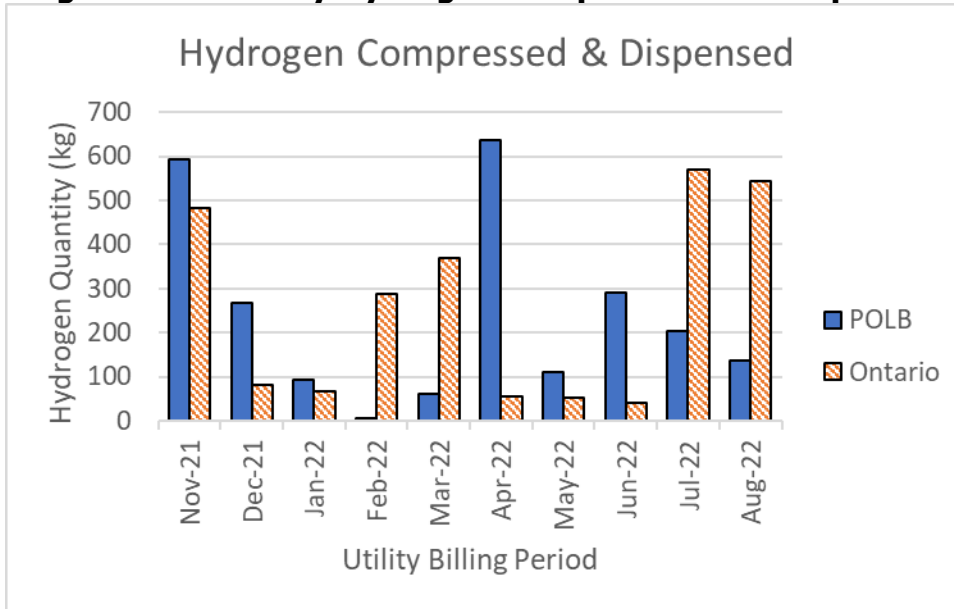

Figure 67 shows the total monthly hydrogen quantity compressed and dispensed by each station throughout the year of data collection. Each station encountered some equipment failures and other issues that took the hydrogen dispensers offline temporarily. These values assume all hydrogen that was dispensed was compressed, and losses from venting and maintenance activities were less than 10%.

Figure 67. Monthly Hydrogen Compressed and Dispensed



From the monthly utility energy and hydrogen totals, Figure68 and Figure69 show monthly estimates of the specific energy, in MJ/kg, used for compression and dispensing for the POLB and Ontario stations, respectively. These estimates assume 60% of the total energy is used for compression and 35% of the total energy is used for precooling, which is included in the dispensing portion.

Figure 68. Monthly Energy Consumption and Hydrogen Quantity for POLB Station

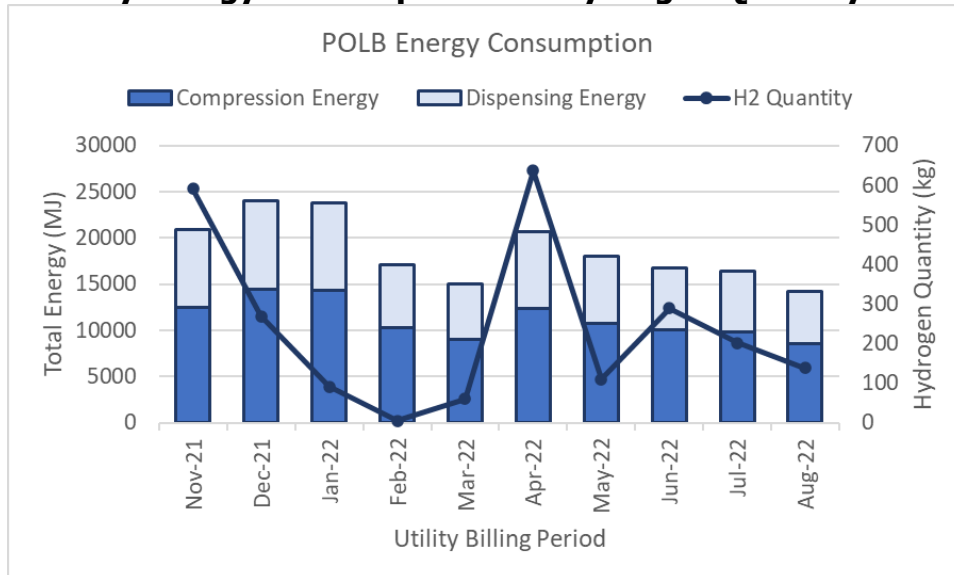
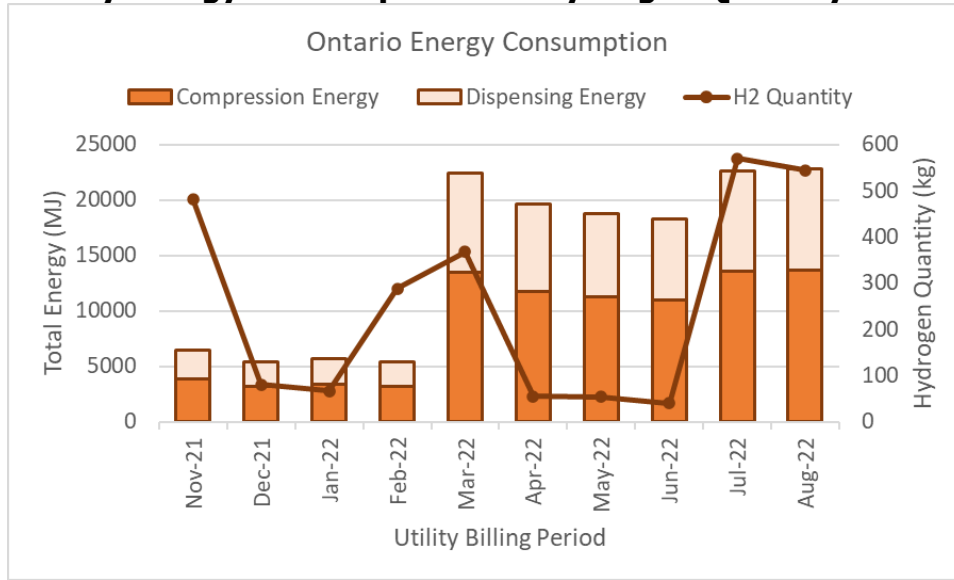

Figure 69. Monthly Energy Consumption and Hydrogen Quantity for Ontario Station



3.4.2 Hydrogen Fueling Events

The fueling records provided by Shell include a total of 1,178 fueling events between August 2, 2021, and September 9, 2022. These fueling events were distributed between four dispensers (78, 80, 86, and 87), with two at POLB and two at Ontario stations.

These fueling records indicate that fueling events occur steadily throughout the day, from approximately 5:00 a.m. until 2:00 p.m., with a peak between 7:00–9:00 a.m. and another slight peak just after noon (Figure 70). The records also show fueling events typically occurring during weekdays only (Figure).

Figure 70. Hydrogen Station Fueling Time of Day

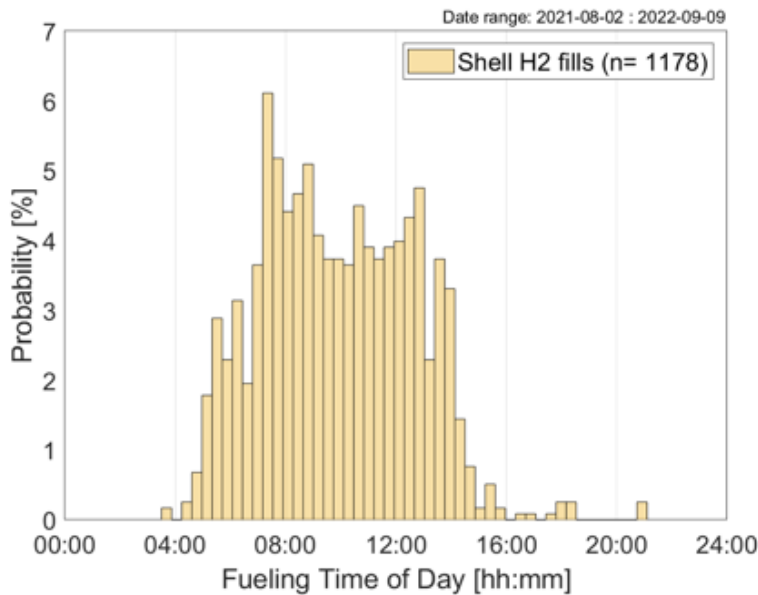
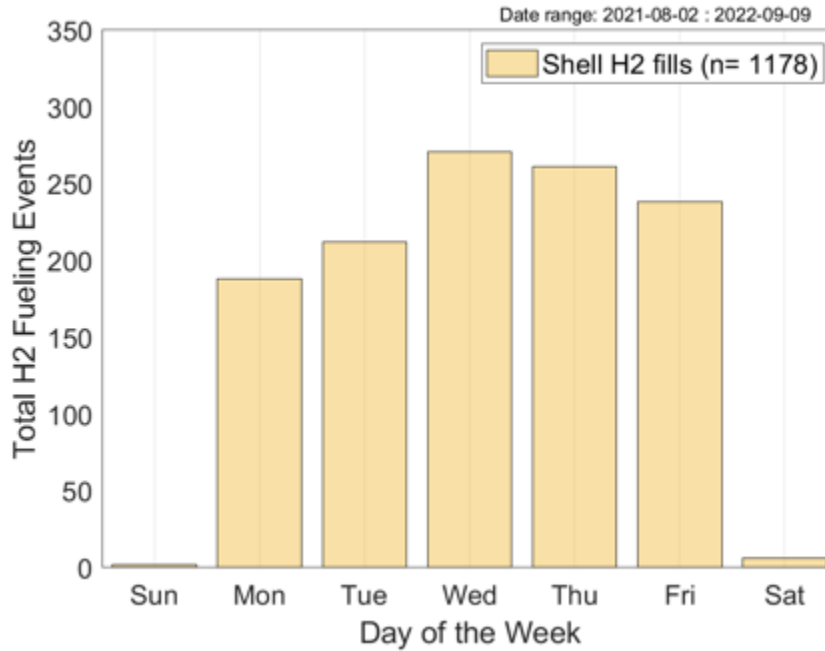

Figure 71. Hydrogen Station Fueling Day of Week



A distribution of hydrogen fuel quantity, shown in Figure72, reveals that almost 25% of the fueling records are less than 1.0 kg. This indicates that many of the fueling events were restarts after failed attempts or partial fills.

Figure 72. Hydrogen Station Fuel Quantity per Fill

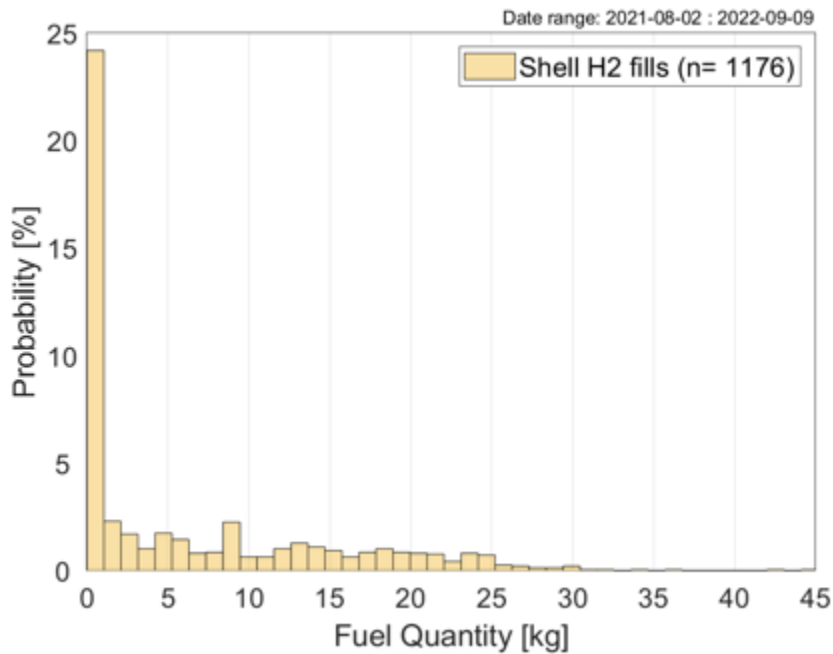

Figure 73 is a scatter plot of fuel quantity vs. fill time for each fueling record to display the average fueling rate for each event. The data points are separated into four groups according to fuel quantity, with the average fueling rate for each group shown by the corresponding trend line. Fueling events with less than 1 kg or no recorded fill time were excluded. For the group of low-quantity fills (1–10 kg), there are several events with very low quantities (less than 5 kg) and very long fill times (more than 10 min) that negatively impacted the average fueling rate. These events were likely cascade fills delivered while the station compressor was inoperable, whereby enough hydrogen could be delivered from the station’s high-pressure storage tanks to a vehicle’s low-pressure fuel tank to enable it to travel to the next closest hydrogen station. This type of fill takes much longer than a standard fill.

Figure 73. Hydrogen Station Fuel Quantity vs. Fill Time

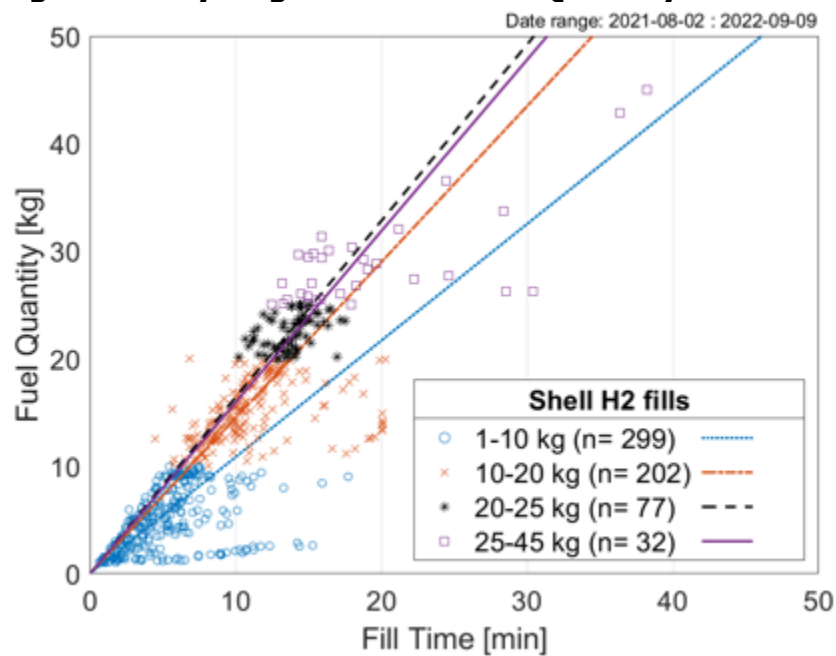
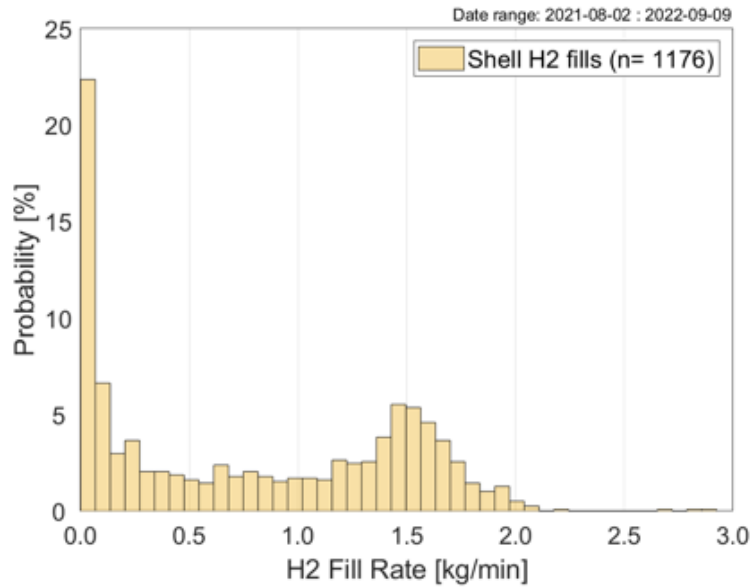

Figure 74 shows a distribution of the fueling rates for all events. If the large number of very low fueling rates (less than 0.2 kg/min) are excluded, a typical fueling rate is 1.5 kg/min for the Ontario and POLB hydrogen stations.

Figure 74. Hydrogen Station Fueling Rate



The hydrogen refueling stations sold hydrogen at a retail price of \$16.45/kg throughout the duration of the project.

3.5 Battery-Electric Yard Tractors

NREL was granted access to collect operational data for two electric terminal tractors operating at POH via the ViriCiti data portal (now ChargePoint). Data recorded by the onboard telematics system include daily mileage, hours of operation (driving and idling), number of charging events, and battery state of charge parameters, and covered operation of the vehicles between January 24, 2022, and January 25, 2023. A photo of one of Kalmar’s electric yard tractors is shown in Figure 75. Table 6 outlines the overall operational statistics for the electric yard tractors during the data collection period.

Figure 75. Kalmar Electric Yard Tractor



Table 6. Operational Statistics for Electric Yard Tractors

-	POH 265	POH 266
Days operated	83	100
Total distance [mi]	1,327.5	1,422.1
Total time operating [h]	777	867
Total time charging [h]	859.4	1,015.8
Total energy charged [kWh]	4,702	4,971
Energy efficiency [kWh/mi]	3.54	3.50
Energy efficiency [kWh/h]	6.05	5.73
Average driving speed [mph]	7.21	7.50
Idle time fraction [%]	76.29	78.13

3.5.1 Electric Yard Tractor Operational Data Summary

The heat maps in Figures 76 and 77 show the hourly distance driven for each of the vehicles during the data collection period. The vehicles were used approximately 1–2 days per week, except for periods when a vehicle was down for repairs.

Figure 76. Heat Map of Hourly Distance Driven for POH 265

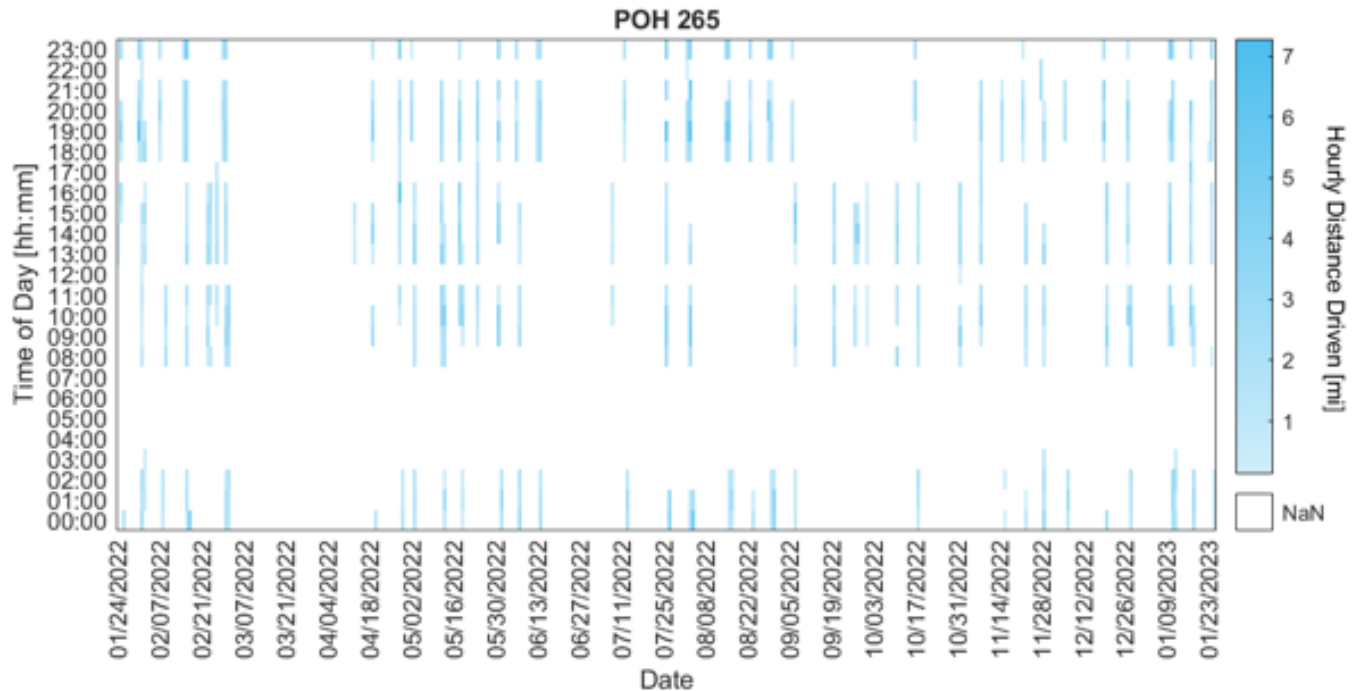
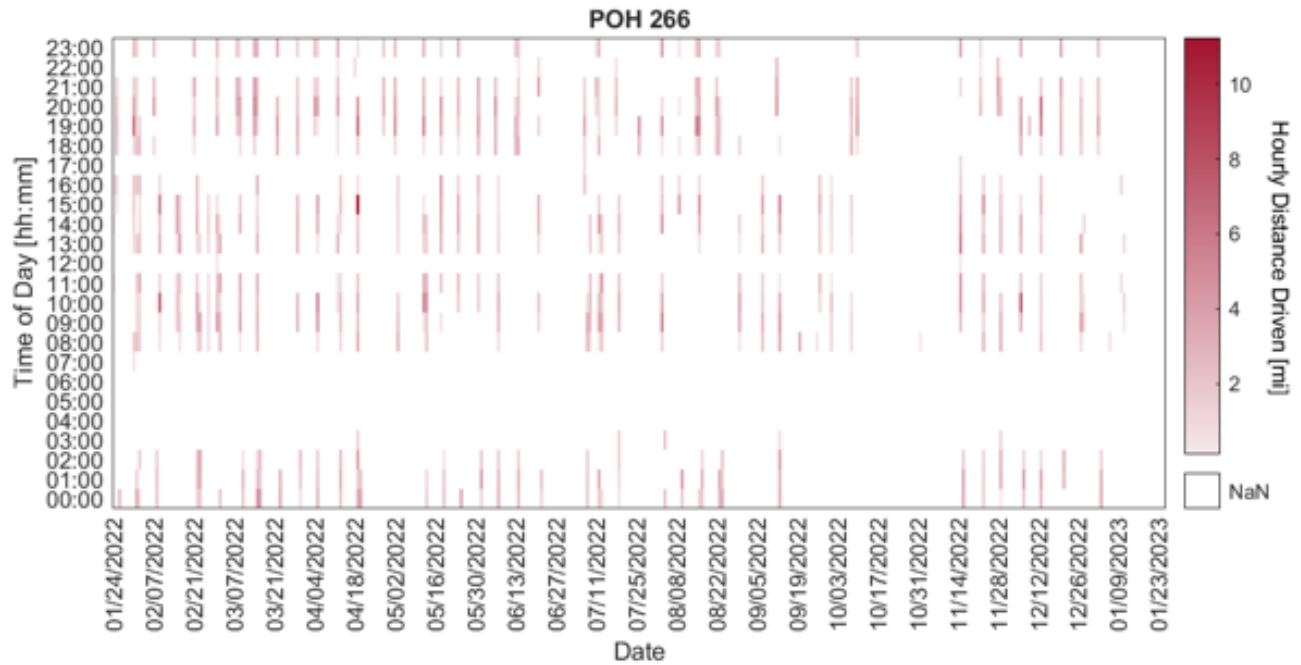
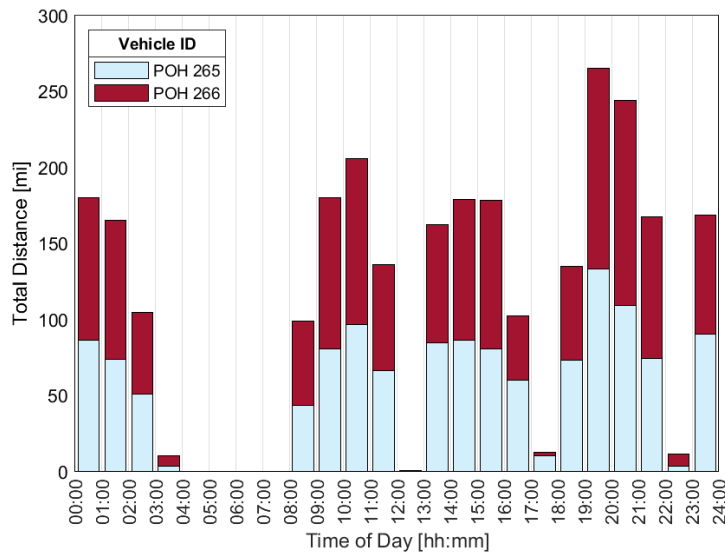

Figure 77. Heat Map of Hourly Distance Driven for POH 266



The heat maps reveal a pattern in the electric yard tractor operation with regard to the work shifts. To highlight this pattern, Figure 78 shows the total distance driven for each vehicle grouped into time-of-day bins. On days when the vehicles are used, they are typically operated between 8 a.m.–noon, 1–5 p.m., 6–10 p.m., or 11 p.m.–3 a.m. The figure clearly shows break periods between shifts, during which the vehicles are rarely operated. The breaks occur from noon–1 p.m., 5–6 p.m., 10–11 p.m., and 3–8 a.m.

Figure 78. Total Distance Driven by Time of Day



When the vehicles are operated, they spend a lot of their engine-on time sitting stationary, or “idling,” rather than driving, as shown in Figure 79. The electric yard tractors had approximately 76%–78% idling time, on average. Although driving requires much more energy than idling, Figure 80 shows that the electric yard tractors used 25% of their battery energy while idling.

Figure 79. Driving and Idling Time Fraction for Electric Yard Tractors

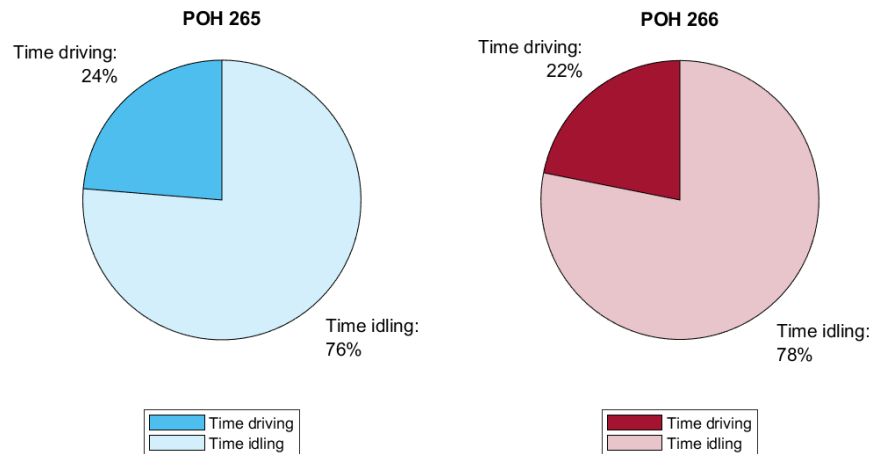

Figure 80. Driving and Idling Energy Fraction for Electric Yard Tractors

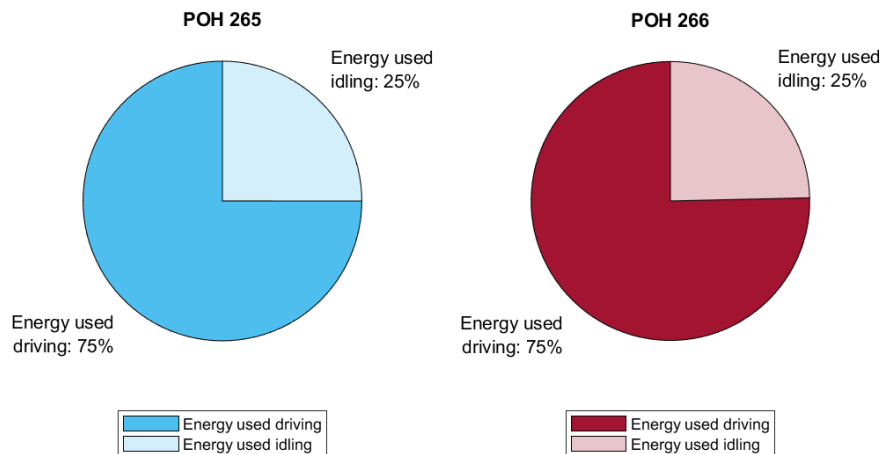
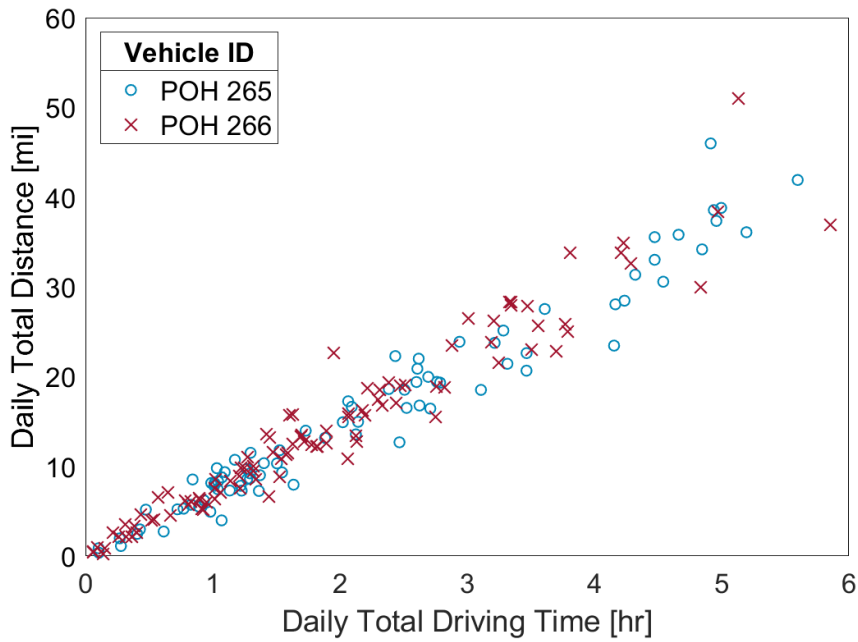

Figure shows the relationship between daily distance traveled and daily driving time for the two electric yard tractors. The maximum daily driving time was nearly 6 hours, and the maximum daily distance was just above 50 miles, yet most of the daily operation of the vehicles was skewed more toward the lower end of the time and distance ranges.

Figure 81. Daily Distance vs. Daily Total Driving Time for Electric Yard Tractors



Average driving speeds (excluding idling time) were around 7 mph, while overall average speeds (including idling time) were around 2.5 mph (Figure 82).

Figure 82. Average Speed, Overall and Driving

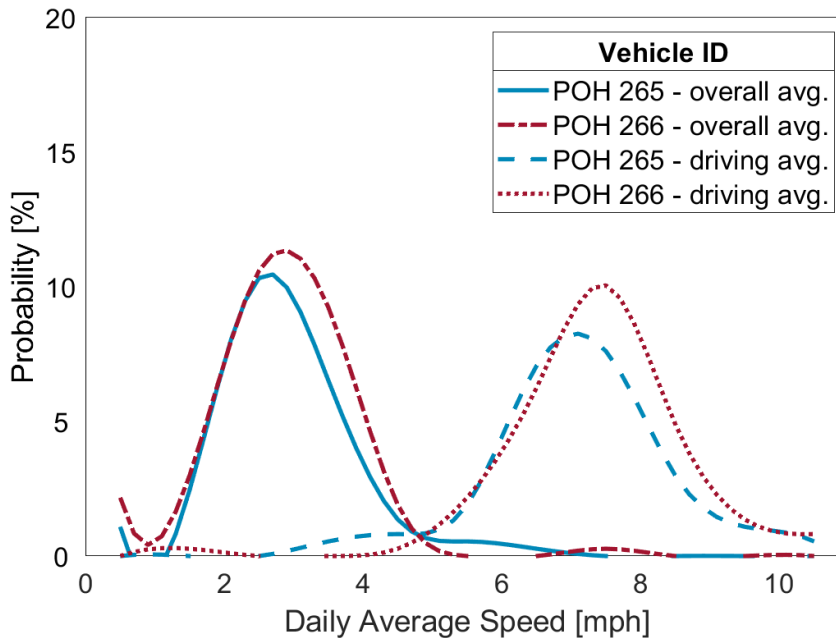
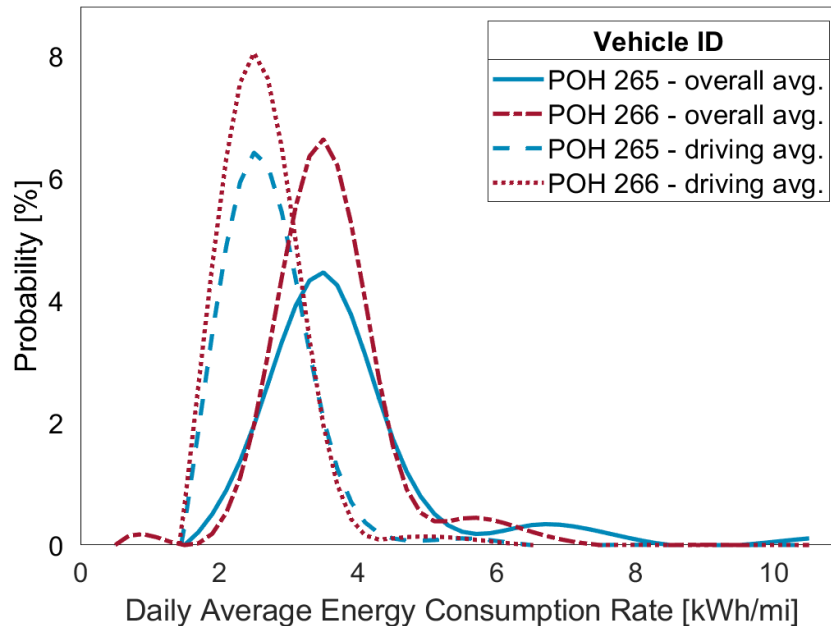

Figure 83 shows the distribution of daily energy consumption rate, indicating a driving average of approximately 2.7 kWh/mi and an overall average (including idling operation) around 3.7 kWh/mi.

Figure 83. Average Energy Consumption Rate, Overall and Driving



3.5.2 In-Use Demonstration Experience (i.e., Operator Surveys)

Driver surveys for the electric yard tractors were provided to POH with a request to distribute to drivers as was done with the Ocean trucks. However, negotiations with the union over many months never reached an agreement to have the drivers fill out the surveys. As a result, there is no driver feedback available for the electric yard tractor performance.

3.6 Battery-Electric Forklifts

TLS operates a group of 2,500–3,500-lb-lift-capacity forklifts in both 36V lead acid battery-electric and propane power. The forklifts range in age from 1 to 20 years old and are a mix of stand-up and sit-down types but perform similar functions. These forklifts do not have any option for electronic data collection, and being operated indoors means GPS is not available.

NREL was given a file of hour logs spanning 8 months that were filled out as part of a daily safety inspection. A comparison of the hours of usage was completed, but detailed analyses of duty cycle and energy consumed were not available. The records are a bit unreliable with many days missing, so a daily usage analysis is unavailable. In general, the units were each used 1 to 3 hours per day. Monthly comparisons were conducted to smooth over the missing data and get a reliable comparison between powertrains. The seven electric forklifts were consistently used more than the propane units each month of the available data. Figure 84 shows the monthly variation in range for each group. Note that with only three propane units the box plots are more condensed. Additionally, taking the manufacturer specification for energy usage of the newest electric forklift, 5 kWh per hour of operation, energy use for an

electric forklift was calculated showing the forklifts each use in the range of 100–300 kWh per month. Figure 85 shows the range of estimated energy use per forklift at TLS.

Figure 84. Monthly Hours of Use for Electric and Propane Forklifts

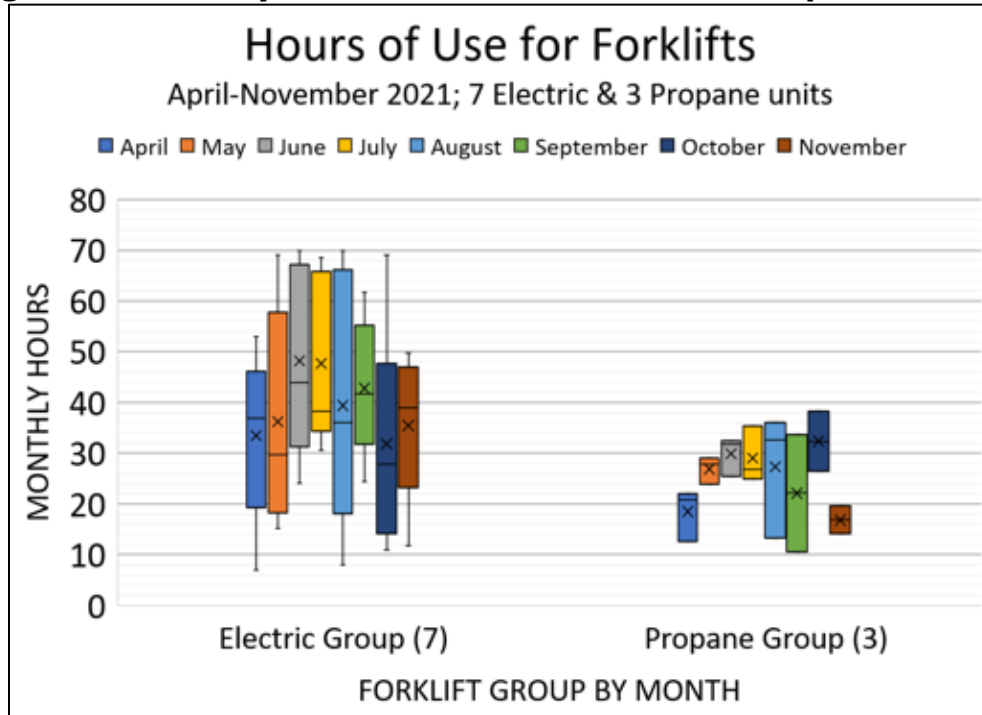
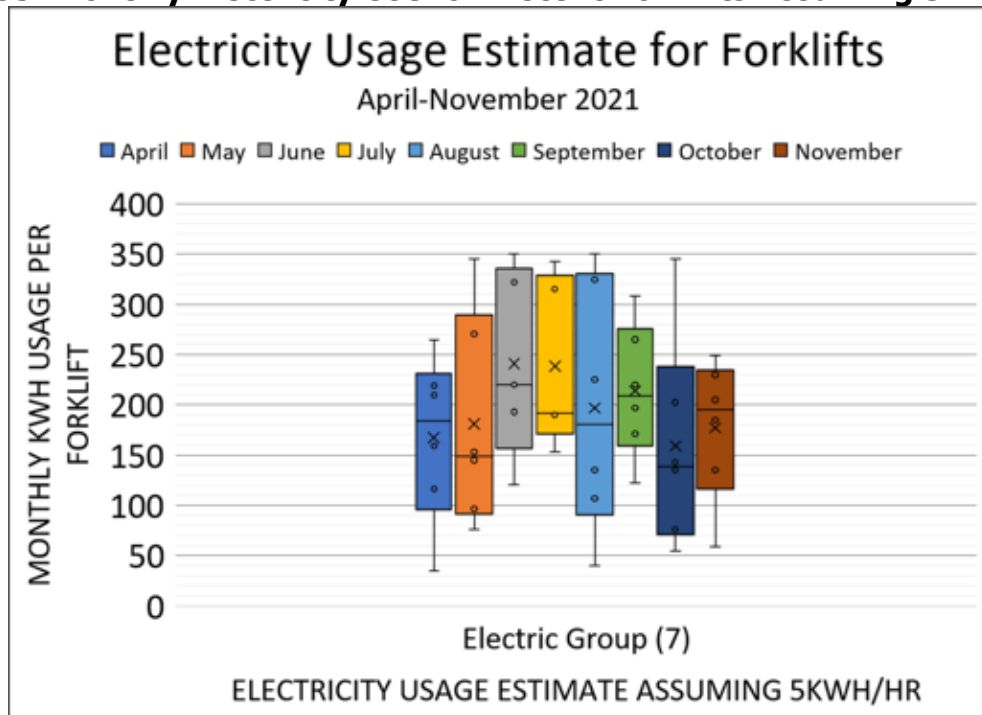

Figure 85. Monthly Electricity Use for Electric Forklifts Assuming 5 kWh/hour



Section 4: Findings and Recommendations

4.1 Summary of Results

The S2S project team demonstrated the technical feasibility of Class 8 FCEV trucks in rigorous goods movement operation and expanded the use of zero-emission equipment at warehouse facilities. This project resulted in direct localized emission reductions in designated disadvantaged communities, initiated a leap to ZE technology for a new class of on-road goods movement vehicles, expanded the use of ZE technology in off-road warehouse equipment, and provided multiple sources of hydrogen throughout the region. Project benefits include:

- Supported bold, transformative emission reduction strategies demonstrated throughout available freight facilities.
- Demonstrated potential for commercialization and transformation of the industry while holistically achieving greenhouse gas, criteria pollutant, and toxic emission reductions benefitting disadvantaged communities.
- Built upon advances from previous demonstration projects by expanding the type and numbers of zero-emission and near-zero-emission equipment used in goods movement operations and facilitating the opportunity for technology transfer from other applications.
- Reduced greenhouse gas emissions and provided economic, environmental, and public co-health benefits to disadvantaged communities while synergistically demonstrating the practicality and economic viability of widespread adoption of advanced ZE technologies.

Below is a discussion of project results for each element of the S2S project.

4.1.1 Hydrogen Infrastructure

Ten months of hydrogen station performance data and approximately 1 year of individual fueling records for two fueling stations were collected for Ontario and POLB. The monthly quantity of hydrogen compressed and dispensed at the fueling stations was highly variable, ranging from a low of 40 kg to a high of 570 kg for Ontario and a low of approximately 6 kg up to a high of 636 kg for POLB. The respective totals over the 10-month period—2,548 kg and 2,395 kg—were similar between the two stations. The electrical energy consumed by the stations was more stable on a monthly basis, with Ontario consuming just under 41,000 kWh and POLB consuming just under 52,000 kWh. It is assumed 60% is used for compression, 35% used for precooling, and the remaining 5% for dispensing and other ancillary uses and system losses. The average cost for electricity consumed by the stations was \$0.35/kWh for Ontario and \$0.48/kWh for POLB. Thus, the resulting electricity cost per unit of hydrogen dispensed was approximately \$5.57/kg for Ontario and \$10.40/kg for POLB.

The total station electricity cost per kg of hydrogen dispensed was very high because the station works continuously to keep the cooling system available and run the other ancillary systems that require electrical power even when there are no trucks fueling. The overall station utilization was low during the demonstration period, and therefore the electricity costs were spread out over a relatively small volume of kg dispensed. Electricity cost per unit of hydrogen dispensed is expected to decrease significantly with higher station utilization and larger dispensed hydrogen volumes.

Fueling records from the two stations contained more than 1,100 fueling events from four dispensers. Refueling events occurred almost exclusively during weekdays and were generally distributed evenly throughout the day, between 5:00 a.m. and 2:00 p.m., with a slight peak around 8:00 a.m. A significant fraction of the fueling events were less than 1.0 kg, indicating that many of them were restarts after failed attempts or partial fills. For fueling events greater than 1.0 kg, a typical fueling rate was approximately 1.5 kg/min for the Ontario and POLB stations.

4.1.2 Ocean Truck Demonstration Fleet

Over a period of approximately 13 months, 21,650 miles of in-service operational data were collected and analyzed from the 10 FCEV Ocean trucks completing drayage operations across four different fleets. The analysis completed by NREL showed daily average fuel economy ranged from 6.1 to 8.2 MPG_{DE} across the fleets, and daily average distances ranged from 45 to 65 mi. On average, the Ocean trucks in the various fleets consumed between 67 and 112 kWh of propulsion energy per day, and they were observed to have an average daily run time between 2.5 and 6.7 hours. Average fuel consumption of the Ocean fleet varied between 0.150 and 0.187 kg_{H2}/mi.

There were some notable differences in the operational characteristics of the Ocean and baseline fleets. The Ocean trucks were driven shorter daily distances and at lower speeds on average than the baseline trucks. Given these shorter travel distances, the Ocean trucks also saw significantly lower daily average energy consumption and shorter daily engine run times. However, the maximum daily driving distance, engine run time, and stack energy of each of the Ocean fleets suggest that these trucks are capable of meeting more demanding operational needs than what was observed in this study. The FCEV Ocean trucks in this study were able to perform this drayage operation with similar average fuel economy as the conventional vehicles in the baseline fleets despite spending a larger portion of their driving on urban and congested roadways. Other factors such as differences in payload weight can have a significant impact on the fuel economy of these vehicles as well. However, this demonstration not only showed viability for Class 8 FCEVs in drayage operations of these distances and provided the immediate benefit of reducing direct localized emissions, it also showed that the first-generation technology used in these vehicles is equivalent to the fuel economy performance of conventional Class 8 diesel trucks. The present state of this technology, along with performance improvements expected as the technology matures further and is optimized for heavy-duty trucks, indicates there is opportunity for improvements in fuel economy over conventional vehicles in this type of operation.

4.1.3 Battery-Electric Yard Tractors

NREL utilized onboard telematics data to characterize operation of the electric terminal tractors for 1 year (January 24, 2022, to January 25, 2023). Combined, the two units operated on 183 days during the data collection period, traveling almost 2,750 miles. The electric tractors were typically used 1–2 days per week and exhibited very consistent schedules corresponding to the operators’ work schedule and break periods. The electric tractors spend less than 25% of their operational time driving, while more than 75% of the time is spent in “idle” or accessory-only mode. However, in terms of energy consumption, 75% is spent driving the tractor and 25% is spent idling. The average overall speed for the electric tractors was approximately 2.6 mph, which is very similar to the baseline yard tractor operation, which was just under 3 mph. The average daily distance traveled was also very similar between the baseline and electric tractors, at 16 miles per day and 15 miles per day, respectively. The electric tractors consumed 3.7 kWh/mi, which is much lower than the baseline tractors’ equivalent energy consumption rate of 13.9 kWh/mi (2.7 mpg), highlighting the energy efficiency benefit of the electric powertrain for this type of vehicle operation.

4.1.4 Battery-Electric Forklift

Eight months of forklift operations were evaluated. The 2,500–3,500-lb-lift-capacity forklifts use both 36V lead acid battery-electric and propane power, stand-up and sit-down types, and a range of ages all performing similar functions. In general, the units are used 1 to 3 hours per day each, with the electric units generally being used more than the propane units. Using the manufacturer specification for energy usage of the newest electric forklift, 5 kWh per hour of operation, energy use was calculated for the electric forklifts showing they each use in the range of 100–300 kWh per month.

4.1.5 Project Costs and Schedule Overview

The S2S project introduced hydrogen fuel into the Southern California drayage truck market by demonstrating near-commercial heavy-duty hydrogen fuel cell electric trucks at and between freight facilities throughout the region, while continuing to lay the groundwork for battery-electric operations. S2S project includes 10 Class 8 hydrogen fuel cell electric trucks, two heavy-duty renewable hydrogen fueling stations, two battery-electric yard tractors, and two ZE forklifts. The S2S project is part of California Climate Investments, a statewide initiative that puts billions of Cap-and-Trade dollars to work reducing greenhouse gas emissions, strengthening the economy, and improving public health and the environment—particularly in disadvantaged communities. Table 7 provides a breakdown of CARB and match funding by task, and Table 8 summarizes the funding contribution from each partner.

Table 7. Project Budget Expenditure Summary

Task No.	Task Description	CARB Grant Funding	Match Commitment	Total
1	Administrative and Project Management	\$100,000	\$25,999,331	\$26,099,331
2	Design, Construction, and Commissioning of Hydrogen Infrastructure	\$17,100,000	\$1,400,000	\$18,500,000
3	Truck Fleet Design, Build, and Support	\$18,573,241	\$10,820,000	\$31,250,000
4	Yard Tractors and Charging Infrastructure	\$4,708,759	\$200,000	\$3,200,000
5	Technology Demonstration	\$0	\$3,007,281	\$3,007,281
6	Data Collection and Analysis	\$640,260	\$0	\$492,260
-	Total:	\$41,122,260	\$41,426,612	\$82,548,872

Source: Port of Los Angeles

Table 8. Project Funding Partners

Funding Partner	Funding Amount
Port of Los Angeles	\$13,999,331
California Air Resources Board	\$41,122,260
South Coast Air Quality Management District	\$1,000,000
OEMs and Demonstration Partners	\$26,427,281
TOTAL:	\$82,548,872

Source: Port of Los Angeles

4.1.6 Project Benefits

Successful implementation of this project demonstrated the technical feasibility of Class 8 FCEVs in rigorous goods movement operation and expanded the use of ZE equipment at warehouse facilities. This project resulted in direct localized emission reductions in designated disadvantaged communities, initiated a leap to zero-emission technology for a new class of on-road goods movement vehicles, expanded the use of ZE technology in off-road warehouse equipment, and provided multiple sources of hydrogen throughout the region.

South Coast AQMD, CARB and CEC support hydrogen and fuel cell technologies and recognize that light-, medium- and heavy-duty vehicles must achieve zero-emissions for the region to meet state and federal air quality attainment standards. Successful implementation of this

project is helping to ensure that sufficient hydrogen infrastructure is available to support the demonstration and early-market introduction of ZE fuel cell electric vehicles, including drayage and regional Class 8 trucks for goods movement. Use of ZE heavy-duty trucks further supports the state's goals in reducing emissions from goods movement programs, including the Sustainable Freight Action Plan. Increased deployment of fuel cell electric vehicles is expected to provide reduction of criteria pollutants from heavy-duty trucking activities, especially in disadvantaged communities that are disproportionately exposed to harmful diesel emissions, such as the San Pedro Bay Ports and Inland Empire area.

The Ports of Los Angeles and Long Beach have emissions reduction goals laid out in the San Pedro Bay Ports Clean Air Action Plan. One of the goals included in the plan is to phase out non-zero-emission drayage trucks by 2035. Using only POLA and POLB as an example, a total of ~17,000 drayage trucks operate in and out of these two ports. The transition plan alone at POLA and POLB represents a significant fleet of trucks targeted for replacement with ZE technologies such as hydrogen fuel cells.

This project is the culmination of a long series of investments and demonstrations made by POLA over the last decade. As several successful and ongoing demonstrations of zero-emission technologies in a wide variety of applications have begun to show the ability to perform the tasks needed, the focus must now shift to the future, and focus on widespread deployment and infrastructure support to allow for zero-emission freight movement across the region, state, and beyond.

For the 59,212 miles of zero-emission operation, the vehicles reduced emissions by an estimated total of 15.5 kg NOX (0.163 g/km), 1.01 kg SOX (0.0106 g/km), and 304.8 metric tonnes of CO₂e (3.2 kg/km) compared to the diesel baseline vehicles including both tailpipe emissions and the emission from producing the fuel sources.

Kenworth Truck Company Benefits

Kenworth benefited from this experience of developing and building the Ocean fleet zero-emission chassis. Kenworth assembled a ZE vehicle development team that acquired expertise in developing, testing, and validating FCEV technology. The knowledge and experience gained during the project are extremely valuable and can be applied to future iterations and development projects. In addition to creating a ZE chassis that fully function in real-world operation, the team also gained experience designing, developing, and controlling electric components including traction motors, DC-DC converters, coolant and lubrication pumps, A/C compressors, cooling fan modulates, air compressors, power steering systems and HVAC systems.

Further, Kenworth gained experience in developing a robust fault management and diagnostic system for fuel cell electric vehicles. Kenworth also gained experience in installing and programming data loggers that can upload large volumes of data over cellular networks. It also provided an opportunity for Kenworth engineers to extract, transform and load the data for advanced data analysis and visualization.

4.2 Lessons Learned

During the initial phase of the hydrogen fuel cell electric truck development, Oceans 1–5, the teams faced many challenges. Opportunities for improvements were discovered and implemented for improved truck function, with the most significant lesson learned being the early prototype nature of high-voltage components available at the time the trucks were built, especially for commercial vehicle applications. Multiple components either did not function on arrival from the manufacturer, could not handle the requirements that were placed on them in a commercial vehicle setting, or failed due to fatigue. Significant collaboration with suppliers, and investments, need to be made before commercial vehicle OEMs gain access to high-quality durable components. It is possible to assemble research and development vehicles with off-the-shelf components; however, they cannot be used to make high-quality, heavy-duty production commercial vehicles.

The Ocean trucks continue to provide valuable lessons learned as prototypes for future generations of ZE Class 8 hydrogen fuel cell electric trucks. The trucks were successfully integrated into the fleets of SCE, TTSI, UPS, and TLS. The Ocean truck fleet operated well as demonstration models in revenue service throughout the intended region. Drivers were generally positive about vehicle performance and comfort. Important data continue to be gathered regarding fuel economy and energy consumption, displacement of fossil fuels and greenhouse gas reductions. Once demonstration and data analysis of baseline and advanced vehicles are complete, the project team expects meaningful information to enable future models of ZE Class 8 hydrogen fuel cell electric trucks to meet the demands of diesel counterparts. Kenworth and Toyota intend to continue collaborating on these future generation models.

The hydrogen fueling stations provided lessons learned that Shell is implementing across future station builds. All failures that occurred were logged and studied for similar and repeated issues, then searched for groupings and repeated issues. Based on the issues, frequency, and amount of time to repair, the issues were rank-ordered and prioritized for resolution. Ongoing engineering improvements took place across all fueling sites with upgrades to hardware and software. Over the course of the demonstration, the Shell team made progress perfecting component and software performance, as well as fueling protocols.

The most important lesson learned from the battery-electric yard tractor demonstration is to minimize exposure of the battery packs. As seen on this project, as well as other terminal demonstrations, heavy impact usage occurs with cargo handling equipment during terminal operations. The battery packs are exposed and therefore susceptible to potential thermal events. In response to the battery pack vulnerability and the heavy impact of terminal use on the equipment, POH fabricated a battery guard solution in-house. This concept was addressed with Kalmar and the company is reviewing development of battery guards and a fire suppression system for future generations.

4.3 Significant Challenges

As discussed throughout this report, due to the COVID-19 pandemic and mandated Safer-At-Home orders, the project encountered administrative, production, supply chain, and infrastructure delays. Factory and facility closures, travel bans, and state and local schedule cancellations continued to adversely impact the project timeline. Although easing somewhat in Q3 2021, travel restrictions imposed on both Kenworth and Toyota continued to limit technicians and engineers from on-site and hands-on collaboration. Travel restrictions initially delayed NREL's scheduled data logger deployment on the baseline vehicles and altered the standard deployment procedure. Factory closures and furloughs delayed the yard tractor procurement process for the Port of Hueneme. Southern California Edison was diverted to wildfire prevention measures, causing significant infrastructure delays at POH. The Los Angeles Department of Water and Power was also diverted by wildfire measures and COVID-19 restrictions, causing delays for power to the Wilmington fueling station. Additional COVID-19 restrictions resulted in appointment cancellations and scheduling delays at Shell's Ontario station build, which included the 350 bar fill, DMS meter measurement, and the CARB HyStEP device.

Despite COVID-19 restrictions, the team continued to collaborate and construct positive ways to move the project forward. However, due to these external conditions, the project experienced impacts to progress during 2021 and into 2022. POLA and the POH continued to focus on maintaining cargo throughput during this unprecedented time, while continuing to support development of advanced technology infrastructure and equipment.

Although the pandemic situation improved slightly during Q3 2021, repercussions continued to impact the supply chain during Q4 2021 and into 2022. Throughout these challenging situations, the Shore to Store team continued to coordinate their efforts and come up with creative collaborative solutions to support the project.

Although several challenges were encountered regarding functionality of the fueling stations, the Shell team continues to improve every detail—from parts and installation to software and fueling protocols. The Shell team has expressed commitment to hydrogen fuel and plans to develop supporting infrastructure on an expanded scale.

Operators of the battery-electric yard tractors at POH are responding favorably to the equipment, although formalized surveys are temporarily held up at POH. The yard tractors are incorporated into daily operations, and the port plans to continue utilizing the equipment beyond the demonstration period.

4.4 Findings and Recommendations

Key findings and recommendations are summarized below.

- The FCEV Ocean trucks in this study were able to perform drayage operation with similar average fuel economy on a diesel equivalent basis than the conventional vehicles in the baseline fleets despite spending a larger portion of their driving on urban

and congested roadways. The Ocean vehicles operated up to 200 miles per day. Based on the analysis performed in this project, substantial greenhouse gas emissions can be achieved depending on the greenhouse gas intensity of the hydrogen production pathway. In addition, a reduction of direct localized emissions can be achieved by implementing zero-emission vehicles like the Ocean trucks in this study.

- The electric yard tractors were typically used 1–2 days per week and exhibited very consistent schedules corresponding to the operators’ work schedule and break periods. The average overall speed for the electric tractors and average daily distance traveled was very similar between the baseline and electric tractors. The electric tractors consumed 3.7 kWh/mi, which is much lower than the baseline tractors’ equivalent energy consumption rate of 13.9 kWh/mi (2.7 mpg), highlighting the energy efficiency benefit of the electric powertrain for this type of vehicle operation.
- The forklifts were typically used 1 to 3 hours per day each, with the electric units generally being used more than the propane units. Using the manufacturer specification for energy usage of the newest electric forklift, 5 kWh per hour of operation, energy use for the electric forklifts was calculated in the range of 100–300 kWh per month.
- The monthly quantity of hydrogen compressed and dispensed at the fueling stations was highly variable; the respective totals over the 10-month period, however, were similar between the two stations. The electrical energy consumed by the stations was more stable on a monthly basis, with Ontario consuming just under 41,000 kWh and POLB consuming just under 52,000 kWh in total. Refueling events occurred almost exclusively during weekdays and were generally distributed evenly throughout the day, between 5:00 a.m. and 2:00 p.m., with a slight peak around 8:00 a.m. A significant fraction of the fueling events were less than 1.0 kg, indicating that many of them were restarts after failed attempts or partial fills. For fueling events greater than 1.0 kg, a typical fueling rate was approximately 1.5 kg/min for the Ontario and POLB stations.

Section 5: Outreach Events

The Ocean truck fleet successfully supported technology awareness and outreach/media relations throughout the project. These events provide critically important opportunities for all stakeholders to “kick the tires” of these innovative zero-emission hydrogen fuel cell electric trucks. Regulators, fleet operators, drivers, and the local communities through which the diesel truck fleet operates, all have a tangible stake in the success of California’s effort to address “disproportionate risks and health and pollution burdens affecting these communities and puts California on the path for an all zero-emission short-haul drayage fleet in ports and railyards by 2035, and zero-emission “last-mile” delivery trucks and vans by 2040.”³ Sharing the results

³ CARB Press Release No. 20-15, “California takes bold step to reduce truck pollution”, <https://ww2.arb.ca.gov/news/california-takes-bold-step-reduce-truck-pollution>, Accessed 12/6/22.

of these demonstration projects, and seeing the trucks out in the community, builds confidence in their future success.

5.1 Project Outreach Efforts

The ZANZEFF project demonstrated technology that facilitated operation of Class 8 trucks with zero carbon emissions and greater range when compared with pure battery-electric alternatives. In addition to the events documented below, the Ocean Truck 7 supported the Road to Zero in Richmond, CA, on August 25, 2022, in partnership with Chevron. On September 13, 2022, Ocean supported a CARB video shoot, with Danny (driver), at Berth 46 (POLA). The video was released at CARB's annual Board of Directors meeting in November 2022. The video will also be available on CARB's website. Additionally, a press release was prepared to mark conclusion of the Ocean trucks' demonstration. Additional information regarding the other outreach events is provided below.

5.1.1 Kenworth Fuel Cell Electric Truck in Washington, D.C.

Key federal government agency officials and members of Congress participated in a ride-and-drive event with the Kenworth T680 hydrogen FCEV on Capitol Hill in Washington D.C. (Figure 86) The activities began with a visit from Deputy Administrator Meera Joshi of the U.S. Department of Transportation's Federal Motor Carrier Safety Administration. As documented in this video,⁴ Energy Secretary Jennifer Granholm was joined by White House National Climate Advisor Gina McCarthy for a discussion and ride along in the Kenworth T680 FCEV, where they experienced the truck quietly and cleanly driving through the D.C. area. The following day, members of Congress, committee staff, and trade association executives stopped by for a visit and discussion. "This was a great opportunity to provide a hands-on look at the T680 fuel cell electric vehicle to leading government agency officials and members of Congress and their staffs," said Kevin Baney, Kenworth general manager and PACCAR vice president, "The T680 FCEV program is a key element of Kenworth's industry-leading efforts of 'Driving to Zero Emissions' in the U.S. and Canada."

⁴ <https://www.youtube.com/watch?v=CWQGn1INSVg>

Figure 86. Ocean Truck Showcased at Capitol Hill in Washington, D.C.



Photo Credit: Kenworth Truck Company

5.1.2 Ocean Fleet Marathon

On March 16, 2022, the entire fleet of 10 Ocean FCEV trucks produced combined mileage of 2,430 miles in a single day with an average of 243 miles per truck, highest single day mileage ever recorded during the project including individual truck mileage as well as combined trucks mileage. The route taken by the 10 trucks on Marathon Day is shown in Figure 87.

Figure 87. Map Showing Fleet Route on Marathon Day



Source: Kenworth Truck Company

5.1.3 California Air Resources Board Public Open House

CARB conducted an open house event on May 21, 2022, at its Southern California headquarters, which includes one of the “world’s most advanced vehicle emissions testing and research facilities dedicated to air quality.”⁵ One of the zero-emission Ocean trucks was featured in the zero-emission truck and bus showcase (Figure 88).

⁵ CARB Open House Flyer: https://ww2.arb.ca.gov/sites/default/files/2022-04/CARB_Open_House_Flyer.pdf

Figure 88. Ocean Fuel Cell Electric Truck Showcased at CARB Open House



Photo Credit: Toyota Motor North America

5.1.4 South Coast AQMD Technology Showcase

South Coast AQMD held a Technology Showcase event on May 6, 2022, in Diamond Bar, California. Vehicles featured in this forum were co-funded from South Coast AQMD's Clean Fuels Program. Figure 89 depicts an Ocean truck that participated in this showcase event.

Figure 89. Ocean Fuel Cell Electric Truck Showcased at Technology Showcase



Photo Credit: Toyota Motor North America

5.1.5 Clean Truck Fee Kick-Off Event

The Mayors of Long Beach and Los Angeles, along with officials from both the Port of Long Beach and Port of Los Angeles, unveiled a Clean Truck Fee program on April 1, 2022. Under this program cargo owners would pay up to \$20 per loaded container hauled by drayage trucks in and out of port container terminals. Loaded containers hauled by ZE trucks are exempt from this fee. The Ocean Fuel Cell Electric Zero-Emission trucks made an appearance in this Kick-Off event⁶ (see Figure 90).

Figure 90. Ocean Fuel Cell Electric Truck Showcased at Clean Truck Fee Kick-Off Event



Photo Credit: Toyota Motor North America

⁶ <https://polb.com/port-info/news-and-press/port-of-long-beach-launches-clean-truck-fund-rate-04-01-2022/>

5.1.6 Port of Los Angeles Debut of Ocean Trucks & Fueling Stations

The Port of Los Angeles debuted five Ocean hydrogen-powered fuel cell electric trucks and two hydrogen fueling stations on June 7, 2021, as a part of Shore to Store project outreach event. Five Ocean FCEVs were introduced at the event along with the high-capacity hydrogen fueling stations, located in Wilmington and Ontario, California (Figure 91). These fueling stations are located near POLA and were designed, built and are operated by Shell Oil.

Figure 91. Ocean FCEVs & Shell Hydrogen Fuel Stations near Port of Los Angeles



Photo Credit: (Fleet Owner, 2021)

“Transporting goods between our port and the Inland Empire is the first leg of this next journey toward a zero-emissions future,” Port of Los Angeles Executive Director Gene Seroka said in a statement.⁷ “This project is a model for developing and commercializing the next generation of clean trucks and cargo handling equipment for the region and beyond. Just as the air we breathe extends beyond the port’s footprint so should the clean air and economic benefits we believe this project will yield.”

⁷ Fleet Owner, June 9, 2021. <https://www.fleetowner.com/emissions-efficiency/press-release/21166545/port-of-los-angeles-demonstrates-hydrogen-fuel-cell-electric-freight> Accessed 12/6/22

5.2 Project “Afterlife”

The S2S project successfully showcased a complete ZE supply chain from the time that a ship arrives at POLA until cargo reaches its final storefront destination, realizing a bold and transformative ship/shore-to-store ZE transport vision to serve as a future template for ZE goods movement.

Now that the demonstration is complete, the Ocean trucks will be utilized in various ways to support future development and to broaden technology awareness (future usage remains provisional). Ocean #1, #2, #5, #7, and #9 will be used for events in and around the Southern California area. Ocean #3 will be transferred to Toyota Quality Parts division to test the truck in service. Ocean #4 will be used as a parts truck. Ocean #6 is on showcase at TMM Kentucky. The Kentucky facility, Toyota’s largest factory in the world, was chosen as the location to manufacture fuel cell stacks for next-generation Class 8 trucks. Ocean #8 transferred to Kenworth Australia. Ocean #10 was transferred to the Toyota technical center in Ann Arbor, MI. The project partner logo stickers will remain on the trucks as a branding badge.

Shell will continue to operate and maintain the hydrogen refueling stations to support the committed fleet operators who intend to operate the FCEVs beyond the term of the funding agreement and through the end of the economic lifetimes of the trucks and station equipment. Projections indicate Shell’s expansion of hydrogen fueling stations throughout the region and potential for continued collaboration with S2S project partners.

The Port of Hueneme continues to utilize the battery-electric yard tractors in daily operations. The e-crane equipment and infrastructure are scheduled for commissioning in late March 2023. The S2S project provided POH with their first ZE cargo handling equipment and the port anticipates more units in operational duty in the future.

Several of the S2S project partners continue to collaborate on next-generation iterations of the project components, building on the relationships and lessons learned, to establish a new forward-looking ZE framework for future goods movement throughout Southern California and beyond.