

# Emissions from a Harbor Craft Vessel Using Retrofit Emission Control Technologies

Final Report

Contract No: 03-0405 (2006) and 12-425 (2015),

Prepared for:

**Mr. John Lee**

**Transportation and Toxics Division  
California Air Resources Board**

**1001 I Street,  
Sacramento, CA 95814**

**[ilee@arb.ca.gov](mailto:ilee@arb.ca.gov)**

**[\(916\) 323-8902](tel:9163238902)**



April 2015

Authors:

**Dr. Robert L. Russell Principal Investigator  
Mr. Bill Welch Principal Development Engineer  
Mr. Edward O'Neil  
Principal Development Engineer**

University of California, Riverside  
Riverside, California 92507

# **Emissions from a Harbor Craft Vessel with Retrofit Control Technologies**

## **Disclaimer**

The statements and conclusions in this report are those of the University of California at Riverside's College of Engineering-Center for Environmental Research and Technology (CE-CERT) and not necessarily those of the California Air Resources Board (ARB). The mention of commercial products, their source, or their use in connection with the material reported herein is not to be construed as actual or implied endorsement of such products.

# **Emissions from a Harbor Craft Vessel with Retrofit Control Technologies**

## **Acknowledgements**

The authors express appreciation to the following associates who contributed much to the success of the project and for adding to the knowledge of emissions from the use of retrofit control technologies in commercial harbor craft. We very much appreciate the financial support of the California Air Resources Board throughout the project.

### **United States Navy**

- Mr. Jonathan Dehart
- Mr. Scott MacKredes

### **MARAD Naval Reserve Fleet – Suisun Bay**

- Mr. Joe Pecararo

### **DDC Consulting**

- Mr. Dick DeCorso

### **CCTS, Inc.**

- Mr. Don Fairchild

### **Rypos, Inc.**

- Mr. Brown Beezer

# Emissions from a Harbor Craft Vessel with Retrofit Control Technologies

## Table of Contents

### Contents

<b>Disclaimer .....</b>	<b>2</b>
<b>Acknowledgements.....</b>	<b>3</b>
<b>Table of Contents .....</b>	<b>3</b>
<b>Table of Figures.....</b>	<b>1</b>
<b>Table of Tables .....</b>	<b>1</b>
<b>Executive Summary .....</b>	<b>2</b>
<b>Introduction.....</b>	<b>3</b>
Emission Testing for Marine Applications.....	4
Project Objective .....	5
<b>Test Plan.....</b>	<b>6</b>
Test Fuels .....	6
Test Engines .....	6
Test Cycle and Conditions.....	6
Schedule and Test Plan.....	8
Measuring Gaseous and PM Emissions from Diesel Engines on Harbor Craft .....	8
Measuring the Gaseous Emissions .....	10
Measuring the Particulate Matter (PM) Emissions.....	12
In-Field Sampling and Testing – Practical Issues.....	13
Quality Control/Quality Assurance (QC/QA).....	13
<b>Fuel Properties.....</b>	<b>14</b>
<b>Engine Map and Test Cycle.....</b>	<b>14</b>
<b>Caveats.....</b>	<b>15</b>
<b>Emissions Results and Discussion (November 2014).....</b>	<b>18</b>
<b>Summary and Conclusions.....</b>	<b>31</b>
<b>APPENDIX A .....</b>	<b>32</b>

# Emissions from a Harbor Craft Vessel with Retrofit Control Technologies

## Table of Figures

Figure 1: Partial Flow Dilution System with Single Venturi, Concentration Measurement and Fractional Sampling.....	9
Figure 2: Field Processing Unit for Purifying Dilution Air in Carrying Case.....	11
Figure 3: In-field Illustration of Continuous Gas Analyzer and Computer for Data Logging .....	11
Figure 4: Brake Horsepower Versus rpm for Port Engine Modes 3, 4, 5 Upstream and Downstream of the DPF.....	19
Figure 5: Modal and Weighted NOx Emission Factors.....	22
Figure 6: Modal and Weighted CO Emission Factors.....	22
Figure 7: Modal and Weighted CO <sub>2</sub> Emission Factors.....	23
Figure 8: Modal and Weighted PM Emission Factors.....	23
Figure 9: Modal and Weighted EC Emission Factors .....	24
Figure 10: Modal and Weighted OC Emission Factors.....	24
Figure 11: Modal and Weighted Fuel Consumption Factors.....	28
Figure 12: Upstream OC/EC Ratio, Port Engine.....	28
Figure 13: Downstream OC/EC Ratio, Port Engine.....	29
Figure 14: Modal and Weighted Approximate SO <sub>2</sub> Emissions .....	30

## Table of Tables

Table 1: Test Cycles type "E" for Marine Applications .....	5
Table 2: Test Modes and Weighting Factors for ISO-8178 E5 .....	7
Table 3: Operating Condition Matrix / Sequence.....	8
Table 4: Detector Method and Concentration Ranges for PG-250.....	12
Table 5: Some Properties of Fuels During Testing .....	14
Table 6: Planned & Actual Test Cycle (Feb 2006).....	14
Table 7: Planned & Actual Test Cycle (Nov. 2006).....	15
Table 8: Planned & Actual Test Cycle (Nov. 2014).....	15
Table 9: Emissions and Fuel Consumption for the three testing programs .....	20
Table 10: Emissions and %Reductions in February 2006 and November 2014 by CCTS.....	25
Table 11: Emissions and %Reductions in February 2006 and November 2014 by Rypos DPF .....	25
Table 12: Emissions and %Reductions by CCTS based on average of (February 2006 and November 2006) and November 2014 .....	26
Table 13: Emissions and %Reductions by Rypos DPF based on average of (February 2006 and November 2006) and November 2014 .....	27

# Emissions from a Harbor Craft Vessel with Retrofit Control Technologies

## Executive Summary

In 2006 the U.S. Navy partnered with the California Air Resource Board (CARB) and the Maritime Administration (MARAD) to test two diesel engine emission control technologies on a MARAD self-propelled barge crane. Two emission control technologies were selected for retrofit application to one of the two propulsion Detroit Diesel 12V-71 marine diesel engines on the barge crane. The Clean Cam Technology System (CCTS) combines turbo charging of the original naturally-aspirated engine along with in-cylinder changes to effect internal exhaust gas recirculation (EGR) and thereby reduce particulate matter (PM) and nitrous oxide (NO<sub>x</sub>) emissions. The Rypos active-regeneration diesel particulate filter (DPF) traps and incinerates PM in the exhaust gases.

The purpose of this project was to compare the emissions of the two retrofit control technologies with emissions from an identical baseline engine without retrofits. Testing was conducted in February 2006, and then again after a nine-month operating period in November 2006. The specific plan measured emissions from the starboard (baseline) engine and the controlled port engine on a working harbor craft. Testing followed the ISO 8178-E5 cycle as close as practical for in-use engines installed in a vessel. Testing occurred on open water in and around Suisun Bay, CA.

Results showed that the combined retrofit control technologies reduced overall weighted average emission by 63 to 70% for NO<sub>x</sub>, 63 to 70% for CO, and 83 to 80% for PM in November 2006 and February 2006, respectively. The weighted efficiency of PM control across the DPF was 75% in February 2006 and 61% in November 2006.

The vessel was scheduled to be removed from service by the end of 2014 so it was decided to measure the emissions from the port engine to determine if the efficiency of the emission controls is essentially the same or not after approximately 10,000+ hours of operation. The emissions were measured in November 2014. Relative to the average of the February and November 2006 starboard emissions the modal NO<sub>x</sub>, CO, and PM emissions were reduced by up to 76%, 81%, and 11% respectively. Overall the weighted average emissions reductions using the combined technologies were 62% for NO<sub>x</sub>, 78% for CO, and -20% for PM. There are several observations noted in November 2014 indicating poor maintenance of the port engine and the DPF.

For the port engine the modal PM emissions were reduced by up to 80%, 65%, and 77% across the Rypos DPF for the February 2006, November 2006, and November 2014 data, respectively. Overall the weighted PM emissions were reduced by 75%, 61%, and 72%, for the February 2006, November 2006, and November 2014 data, respectively.

It appears that the piston rings are worn and that “blow-by” is causing lube oil from the crankcase, which is ventilated through filters to the engine inlet air, to be ingested into the engine cylinders.

# Emissions from a Harbor Craft Vessel with Retrofit Control Technologies

## Introduction

In the early 2000's the California Air Resources Board (ARB) approved a measure designed to reduce harmful emissions from commercial ferries, excursion vessels, tugs and towboats in California waters as much as 50% by 2015.

ARB expects the measure to reduce emissions of diesel soot and oxides of nitrogen (NO<sub>x</sub>) by 40-50% by 2015, and by 60-70% by 2025, compared to 2004 levels. The measure for commercial harbor craft did not include recreational or ocean-going vessels.

At the time the measure was introduced, estimated daily statewide emissions from commercial harbor craft engines were approximately 3 tons of diesel soot and 73 tons of NO<sub>x</sub>. In 2006, about 80% of all harbor craft engines in California were unregulated. The new regulation required older engines currently in use on ferries, excursion vessels, tugboats, and towboats to be replaced with newer, cleaner engines meeting US EPA marine engine standards. Replacements were to be phased in starting in 2009, with the oldest, highest-use engines to be replaced first.

The ARB estimated that there were about 4,200 harbor craft vessels and 8,300 harbor craft engines in use in California (with each vessel typically having more than one engine). Of these, there were nearly 600 ferries, excursion vessels, tugboats, and towboats equipped with about 1,900 propulsion and auxiliary engines that would be subject to this regulation.

While these represented only 15% of the vessels (25% of the engines), they generated about 50% of the emissions. Additionally, most of their emissions are generated within the harbor or close to shore and thus have the greatest impact on adjacent communities.

About 40% of these vessels were in the Bay Area, while 30% serviced the ports of Los Angeles and Long Beach. The remainder were scattered throughout the State.

In anticipation of the control measure, The U.S. Navy partnered with ARB and the Maritime Administration (MARAD) to test two retrofit diesel engine emission control technologies on a MARAD self-propelled barge crane. The test vessel is used to maintain the National Defense Reserve Fleet located at Suisun Bay (northwest of San Francisco). The marine propulsion engines on this vessel, Detroit Diesel Corporation (DDC) 12V-71N, are prolific on both military vessels and commercial harbor craft.

The emission control technologies selected for application to one of the twin propulsion Detroit Diesel 12V-71 marine diesel engines was based on NAVSEA-Philadelphia laboratory performance test results and an engineering evaluation of success potential and cost effectiveness. Two lab-tested technologies were deemed worthy of further reliability and durability testing in a shipboard evaluation phase. The Clean Cam Technology System (CCTS) combines turbo charging the base naturally-aspirated engine with in-cylinder changes to effect internal exhaust gas recirculation (EGR) and thereby reduce particulate matter (PM) and nitrous oxide (NO<sub>x</sub>) emissions. The Rypos active-regeneration diesel particulate filter (DPF) traps and incinerates PM in the exhaust gases.

Following modification of the test vessel and engine break-in, shipboard back-to-back

## **Emissions from a Harbor Craft Vessel with Retrofit Control Technologies**

emissions tests (comparing the modified port power train with the baseline starboard power train) were conducted in February 2006. After, a nine month durability evaluation period a second set of shipboard emissions tests were conducted in November 2006 to determine the performance of the emission controls following the durability study.

Real-world operating conditions, targeted to attaining as close to ISO 8178 protocol E5 modes (also used in the lab test) as possible, were selected for emission test data collection. Gaseous and PM data were collected in triplicate at each mode once emissions stabilized. For both the pre- and post-durability tests, baseline performance and emissions parameters were established on the unmodified engine and compared with the port modified engine and exhaust system.

In November 2014, just prior to removing the vessel from service, the emissions from the port engine were measured following the same protocol as used for the February and November 2006 testing. Because the starboard engine had been replaced the emissions from the starboard engine were not measured in 2014.

### **Emission Testing for Marine Applications**

In 2003, the US EPA<sup>1</sup> published compliance limits, test protocols and measurement methods for marine engines in the Code of Federal Regulations (CFR). EPA recognized the duty cycle used in determination of compliance with emission standards was critical and specified duty cycles intended to simulate in-use operation. Testing consisted of operating the engine over a prescribed duty cycle of speeds and loads. To address operational differences between marine engines, EPA adopted five different marine duty cycles dependent on the engine operation and the type of vessel the engine is in. (see Table 1). These are the same duty cycles specified by the International Organization for Standardization<sup>2</sup> (ISO) and IMO Annex VI.

EPA recognized that test conditions, in addition to the test cycle, could affect emissions during the compliance tests so they specified the test conditions as well as the cycle. During discussions with the manufacturer, the EPA was practical and allowed the manufacturer full discretion to adjust certain engine parameters to appropriate settings. For example, parameters such as after cooler and backpressure and air and water temperatures were set using good engineering judgment to select representative values. Also manufacturers were allowed to specify a maximum test speed for testing that selectively includes lower-emission operation, even if those speeds did not represent an engine's actual operation when installed on a vessel. The issue of test conditions is critical for this project since in-vessel testing required that UCR and others accept the "in-use" conditions during the testing.

---

<sup>1</sup> US Environmental Protection Agency, 40 CFR Parts 9 and 94 *Control of Emissions From New Marine Compression-Ignition Engines at or Above 30 Liters Per Cylinder*; Final Rule, February 28, 2003

<sup>2</sup> International Standards Organization, ISO 8178-4 First edition, 1996-08-15, *Reciprocating Internal Combustion Engines - Exhaust Emission Measurement -Part 4: Test Cycles for Different Engine Applications* Reference number ISO 8178-4:1996(E)



## Emissions from a Harbor Craft Vessel with Retrofit Control Technologies

Table 1: Test Cycles type "E" for Marine Applications

<b>Type E1, Mode #</b>	1	2	3	4	5
Speed	Rated speed		Intermediate speed		Low-Idle speed
Torque, %	100	75	75	50	0
Weighting Facto	0.08	0.11	0.19	0.32	0.3
<b>Type E2, Mode #</b>	1	2	3	4	
Speed	Rated speed				
Torque, %	100	75	50	25	
Weighting Factor	0.2	0.5	0.15	0.15	
<b>Type E3, Mode #</b>	1	2	3	4	
Speed, %	100	91	80	63	
Power, %	100	75	50	25	
Weighting Factor	0.2	0.5	0.15	0.15	
<b>Type E4, Mode #</b>	1	2	3	4	5
Speed, %	100	80	60	40	idle
Torque, %	100	71.6	46.5	25.3	0
Weighting Facto	0.06	0.14	0.15	0.25	0.4
<b>Type E5, Mode #</b>	1	2	3	4	5
Speed, %	100	91	80	63	idle
Torque, %	100	75	50	25	0
Weighting Facto	0.08	0.13	0.17	0.32	0.3

The EPA regulation helps to define suitable test cycles and test conditions. In addition, the EPA conditions are similar to those in the ISO and the Annex VI, so the test protocols are internationally accepted.

### Project Objective

The Naval Reserve Fleet at Suisun Bay maintains a variety of diesel powered equipment and vessels in support of their operations. In 2006 some of this equipment had old, diesel engines that were manufactured before regulatory actions were addressed. Accordingly, CARB wanted to measure emissions from a harbor craft vessel with an older engine representative of those in service and unlikely to be replaced in the near future. Furthermore, CARB sought to assess the feasibility of retrofitting such an older engine with control technologies designed to reduce emissions. A key element of this project was the measurement and quantification of potential emissions benefits when using the retrofit control technologies. Towards that end, the University of California, Riverside (UCR), working with CARB, the US Navy and MARAD; conducted the emissions measurement campaigns from two identical harbor craft engines: one with no emission control and one that was retrofit with two retrofit control technologies.

For the current project the objective is to determine if the control technology is still working

## **Emissions from a Harbor Craft Vessel with Retrofit Control Technologies**

at essentially the same efficiency level after 8 years of in-service activity.

### **Test Plan**

The plan called for measuring the emissions from the same port engine measured in February and November of 2006. The engine is one engine on the YSD, or “Mary Anne”, a barge crane used for maintaining the Naval Reserve Fleet at Suisun Bay, CA. The YSD is an older harbor craft working vessel with one uncontrolled diesel engine and one retrofit controlled engine. It represents a vessel that is unlikely to be fitted with a new engine (repowered), and thus is an ideal candidate for a test of retrofit control technologies.

### **Test Fuels**

The YSD makes use of a varying mixture of CARB diesel and salvaged diesel fuels. In this application, the properties of these fuel mixtures can change from batch to batch. To ensure continuity within a given set of tests, a single batch of fuel was used for both the port and starboard engines for the duration of the February 2006 test period. A second batch of fuel was employed in a similar manner for the second test campaign in November 2006. Since, in the November 2014 test program, only the port engine emissions were measured the in-use fuel at the time of testing was used. Samples of the fuels during testing were taken and analyzed to determine the fuel properties of each mixture. Analyses revealed similar fuel properties between the three fuels used in the test program. Detailed fuel analyses are presented in Appendix A.

### **Test Engines**

The YSD employs twin propulsion engines, one on the port and the other on the starboard side. The high-speed diesel engines, model 12V71N, were made by the Detroit Diesel Corporation in the 1980s. These engines use two-stroke technology, and were a market share leader at that time. Because of their popularity and reliability, many of these engines are still used in harbor craft vessels today. The engines (as designed), are naturally aspirated and rated at 432 horsepower at 2185 RPM, with a displacement of 12.96 liters each. Two emission control technologies were selected and installed in 2006 as retrofits on the port engine only. The Clean Cam Technology System (CCTS) combines turbo-charging the original naturally-aspirated engine with in-cylinder changes to effect internal exhaust gas recirculation (EGR); with the goal of reducing particulate matter (PM) and oxides of nitrogen (NO<sub>x</sub>) emissions. The Rypos active-regeneration diesel particulate filter (DPF) traps and incinerates PM in the exhaust system. For the 2006 projects, both the port (modified) and starboard (unmodified) engines were tested. Additionally, two sets of emissions samples were acquired during port engine testing: one upstream and one downstream of the Rypos active DPF. For the November 2014 testing only the emissions from the port engine, upstream and downstream of the Rypos active DPF were measured.

### **Test Cycle and Conditions**

## Emissions from a Harbor Craft Vessel with Retrofit Control Technologies

Normally, the emissions from diesel engines are measured while the engine is in a laboratory and mounted on an engine dynamometer. These types of measurements are typically performed for the purpose of certification. For this project, the performance and emission testing was carried out for engines installed in a vessel. This approach added complexity to the project. The goal is to match the specified certification test points to the extent possible on open water. However, this approach limits the ability to test all the desired modes of operation.

Selection of the cycle and engine operating conditions was considered critical to this evaluation so we followed the EPA guidance and selected the ISO 8178-E5 five-mode test cycle shown in Table 2

*Table 2: Test Modes and Weighting Factors for ISO-8178 E5*

<b>Mode Number (cycle E5)</b>	<b>1</b>	<b>2</b>	<b>3</b>	<b>4</b>	<b>5</b>
	Rated Speed	Intermediate Speed			
<b>Speed, %</b>	100%	91%	80%	63%	Idle
<b>Power, %</b>	100%	75%	60%	25%	0
<b>Weighting Factor</b>	0.08	0.13	0.17	0.32	0.3

In summary, the test sequence is conducted as follows:

- The engine is run at rated speed and full power to warm up and stabilize emissions for 30 minutes.
- A plot or map of the peak power as a function of engine speed is determined for the port and starboard engines, starting with rated speed. As the 100% load point at rated speed is unattainable with the propeller operating torque, Mode 1 was chosen to represent the highest attainable RPM/load.
- Emissions were measured while the engine operated according to the parameters of ISO-8178-E5. Mode 1 is run first; with the highest achievable load determined by the engine map.
- After Mode 1, each mode is run in sequence. The minimum run time is 10 minutes; it is extended at some mode points to collect sufficient particulate sample mass. The modal time period is recorded and reported.
- The gaseous exhaust emission concentration values are measured and recorded for the last 3 min of each mode. The completion of particulate sampling is coincident with the completion of the gaseous emission measurements.
- Engine speed, boost pressure, and intake manifold temperature are measured to calculate the gaseous flow rate at each mode. Engine speed is measured from an optical pickup installed on the engine driveshaft. Torque is measured with a strain gauge mounted on the propeller driveshaft.
- Emissions factors are calculated in terms of grams per brake horsepower-hour for each of the operating modes and sampling locations tested, allowing for emissions comparisons between the baseline and controlled engines, as well as the individual performance of each of the two emission control technologies.

# Emissions from a Harbor Craft Vessel with Retrofit Control Technologies

## Schedule and Test Plan

Each of the two sets of performance tests (Feb. 2006 and Nov. 2006) included the following basic elements of preparation and data collection, and were conducted according to the sequence in Table 3.

- **Days 1-3** - NAVSEA-Philadelphia: Installation of thermocouples, pressure transducers, fuel flow meters, and torque meter.
- **Day 4** - NAVSEA-Philadelphia and University of California, Riverside (UCR): Set up of sampling probes and emissions analyzers, and collection of a fuel sample.
- **Day 5** - NAVSEA-Philadelphia and University of California, Riverside (UCR): Data collection on the port emission controlled engine and exhaust system (engine load and rpm modes acquired).
- **Day 6** - NAVSEA-Philadelphia and University of California, Riverside (UCR): Switchover of instrumentation to the starboard engine and exhaust system and data collection.
- **Day 7** - Instrument removal.

*Table 3: Operating Condition Matrix / Sequence*

Cycle	Mode	Test Point	Rpm (% rated speed)	Load (% full load)	Rpm (target)	Bhp (target)
E5	1	1	100	100	2300	425
	2	2	91	75	2093	319
	3	3	80	50	1840	213
	4	4	63	25	1449	106
	5	5	idle	0	1200	0

The performance testing in November 2014 proceeded as follows with the intention of following the Table 3 sequence of testing.

- **Days 1-6** NAVSEA-Philadelphia: Installation of thermocouples, pressure transducers, plenum for fuel flow measurement, fuel flow meters, and torque meter.
- **Days 1-3** University of California, Riverside (UCR): Set up of sampling probes and emissions analyzers.
- **Day 7** - NAVSEA-Philadelphia and University of California, Riverside (UCR): Data collection on the port emission controlled engine and exhaust system emissions, engine load and rpm modes acquired.
- **Day 8** - Instrument removal.

## Measuring Gaseous and PM Emissions from Diesel Engines on Harbor Craft

## Emissions from a Harbor Craft Vessel with Retrofit Control Technologies

UCR methods for sampling and analysis of the gases and particulate matter (PM) from harbor craft vessels conform to the requirements of ISO 8178-1<sup>3</sup>. The approach involves the use of a partial flow dilution system with single Venturi as shown in Figure 1. Raw exhaust gas is transferred from the exhaust pipe (EP) to the dilution tunnel (DT) through the sampling probe (SP) and the transfer tube (TT) due to the negative pressure created by the Venturi (VN) in DT. The transfer line is heated to prevent condensation of exhaust components (including water and sulfuric acid) at any point in the sampling and analytical systems. For this project, 15 ft. heated transfer lines were used to convey raw exhaust samples to the dilution sampler location.

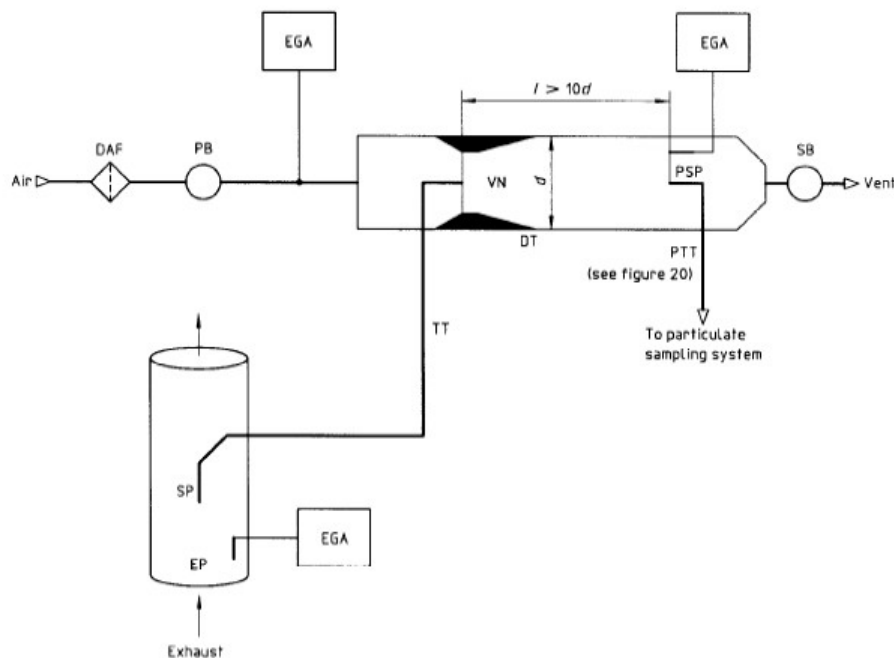

Figure 1: Partial Flow Dilution System with Single Venturi, Concentration Measurement and Fractional Sampling

The gas flow rate through TT depends on the momentum exchange at the Venturi zone and is therefore affected by the absolute temperature of the gas at the exit of TT. Additionally, the flow rate is affected by the static pressure in the raw exhaust duct. Consequently, the exhaust split for a given tunnel flow rate is not constant, and the dilution ratio varies as a function of engine load. The tracer gas concentrations ( $\text{CO}_2$  and  $\text{NO}_x$ ) are measured in the raw exhaust, the diluted exhaust, and the dilution air using the exhaust gas analyzer (EGA). The dilution ratio is calculated from these measured values.

To apply the ISO approach in the field, UCR designed a portable set of equipment that is field deployable. The equipment fits into several metal cases with an interior of foam molding to allow sensitive equipment, like computers, to be easily transported or even

<sup>3</sup> International Standards Organization, ISO 8178-1, *Reciprocating internal combustion engines - Exhaust emission measurement -Part 1: Test-bed measurement of gaseous particulate exhaust emissions*, First edition 1996-08-15

## **Emissions from a Harbor Craft Vessel with Retrofit Control Technologies**

be lifted and dropped into cargo areas on a vessel without harm to the contents. For practical purposes, the design includes pieces of equipment that allow the use of a range of common electrical (120/240V, 50/60Hz) and supply air utilities. For example, while UCR tries to obtain instrument grade pressurized air for dilution air, it further processes the air through a field-deployed filtration/drying unit to assure the quality of the dilution air. The process takes the supply air through a number of steps including reducing the pressure to about 30 psig; resulting in a dilution ratio of about 5/1 with the geometry of our system. The next stages, in sequence, for conditioning the supply air include a liquid knock-out vessel, desiccant to remove moisture with indicating silica gel, hydrocarbon removal with activated charcoal, and a HEPA filter for the fine aerosols that might be present in the supply air. The silica gel and activated carbon are re-charged between each field campaign. Figure 2 shows the unit for processing the dilution air.

### Measuring the Gaseous Emissions

The concentrations of gases in the raw exhaust and the dilution tunnel are measured with a Horiba PG-250 portable multi-gas analyzer. The PG-250 can simultaneously measure up to five separate gas components using the measurement methods recommended by the EPA. The signal output of the instrument is interfaced directly with a laptop computer (see Figure 3) through an RS-232C interface to record measured values continuously. Major features include a built-in sample conditioning system with sample pump, filters, and a thermoelectric cooler. The performance of the PG-250 was tested and verified under the U.S. EPA ETV program.

## Emissions from a Harbor Craft Vessel with Retrofit Control Technologies



*Figure 2: Field Processing Unit for Purifying Dilution Air in Carrying Case*



*Figure 3: In-field Illustration of Continuous Gas Analyzer and Computer for Data Logging*

## Emissions from a Harbor Craft Vessel with Retrofit Control Technologies

Details of the gases and the ranges for the Horiba instrument are shown in Table 4. Note that the Horiba instrument measures sulfur oxides (SO<sub>x</sub>); however, the ISO reference<sup>3</sup> reports that the direct measurement for SO<sub>2</sub> is less precise than calculating the concentration from fuel sulfur analysis.

*Table 4: Detector Method and Concentration Ranges for PG-250*

Component	Detector	Ranges
Nitrogen Oxides (NO <sub>x</sub> )	Heated Chemiluminescence Detector (HCLD)	0-25, 50, 100, 250, 500, 1000, & 2500 ppmv
Carbon Monoxide (CO)	Non dispersive Infrared Adsorption (NDIR)	0-200, 500, 1000, 2000, & 5000 ppmv
Carbon Dioxide (CO <sub>2</sub> )	Non dispersive Infrared Adsorption (NDIR)	0-5, 10, & 20 vol%
Sulfur Dioxide (SO <sub>2</sub> )	Non dispersive Infrared Adsorption (NDIR)	0-200, 500, 1000, & 3000 ppmv
Oxygen	Zirconium oxide sensor	0-5, 10, & 25 vol%

For quality control, UCR carried out analyzer checks with calibration gases both before and after each test to check for drift. Because the instrument measures the concentration of five gases, the calibration gases are a blends of several components (super-blends) certified to within 1% per Federal specifications. Drift was determined to be within protocol specifications of  $\pm 2\%$  full scale per day.

### Measuring the Particulate Matter (PM) Emissions

A raw particulate sampling probe was fitted close to and upstream of the raw gaseous sample probe in the exhaust. To measure PM, a second sampling probe was inserted into the end of the dilution tunnel (>10 diameters downstream) and directed to a PM sample splitter that allowed up to three samples to be collected. The sample stream from the dilution tunnel was conveyed through a cyclone separator, sized to remove particles >2.5 $\mu$ m. From the separator, the sample stream was split immediately upstream of two 47 Gellman filter holders; one for collecting PM on a Teflon filter and the other for collecting PM on a quartz filter. The remaining (bypass) flow in the dilution tunnel was vented outside the vessel. Note that with the partial dilution approach for measuring gases and PM, it is critical for the dilution ratio to be determined very accurately.

UCR collected simultaneous Teflon and quartz filters at each operating mode and analyzes them according to standard procedures. The simultaneous collection of quartz and Teflon filters allows an internal quality check of the PM mass. Teflon (Teflo) filters used to acquire PM mass are weighed following the procedure of the Code of Federal



## **Emissions from a Harbor Craft Vessel with Retrofit Control Technologies**

Regulations (CFR) (40 CFR Part 86). Briefly, total PM is collected on Pall Gellman (Ann Arbor, MI) 47 mm Teflo filters and weighed using a Cahn (Madison, WI) C-35 microbalance. Before and after collection, the filters are conditioned for 24 hours in an environmentally controlled room (RH = 40%,  $T = 25$  C) and weighed daily until two consecutive weight measurements are within 3  $\mu\text{g}$ .

PM samples are collected in parallel on 2500 QAT-UP Tissuquartz Pall (Ann Arbor, MI) 47 mm filters that were preconditioned at 600°C for 5 h. A 1.5 cm<sup>2</sup> punch was cut out from each quartz filter sample and analyzed with a Sunset Laboratory (Forest Grove, OR) Thermal/Optical Carbon Aerosol Analyzer according to the NIOSH 5040 reference method (NIOSH 1996). All PM filters were sealed in containers immediately after sampling, and kept chilled until analyzed.

### **In-Field Sampling and Testing – Practical Issues**

While everything seems quite straight forward in the foregoing description, it is sometimes difficult to measure emissions on a vessel. A number of decisions must be made in the field to adapt to what is achievable. As mentioned earlier, UCR moves all possible gear to the vessel including analytical equipment, pumps, calibration gases, sampling lines, computers, extra fitting, power supplies and a tool kit. Further pumps and other electrical equipment must be set to the correct power and frequency settings.

### **Quality Control/Quality Assurance (QC/QA)**

Each of the laboratory methods for PM mass and chemical analysis has a standard operating procedure including the frequency of running the standards and the repeatability that is expected when the standard is run. Additionally the data for the standards are plotted to ensure that the values fall within the upper and lower control limits for the method and that there are no obvious trends or bias in the results for the reference materials. As an additional quality check, results from independent methods are compared and values from this work are compared with previously published values, like the manufacturer data base.

# Emissions from a Harbor Craft Vessel with Retrofit Control Technologies

## Results and Discussion

### Fuel Properties

Fuel properties from samples acquired in February 2006, November 2006, and November 2014 were determined by Naval Air Systems Command AIR 4.4.5. A summary of key parameters are shown in the following table. The detailed fuels analyses are included in Appendix A.

Table 5: Some Properties of Fuels During Testing

<i>Fuel Property</i>	<i>Feb 2006</i>	<i>Nov 2006</i>	<i>Nov 2014</i>
Density (kg/M <sup>3</sup> @ 15 °C)	0.8574	0.861	0.866
Sulfur, % by mass	0.524	0.5	0.556
Cetane Index	48.8	47.7	46.5
Total Aromatics, % wt	47.3	42.3	37.1
Monocyclic Aromatics, % wt	31.02	26.6	19.1
Dicyclic Aromatics, % wt	16.32	15.7	18.06

### Engine Map and Test Cycle

The planned ISO- E5 test cycle is shown in Table 2 and the actual cycle used in the February 2006 and November 2006 tests are shown in Table 6 and Table 7, respectively. As seen in Table 2, the engine is run at rated or governed speed for Mode 1 and at intermediate speeds for Modes 2, 3, 4 and 5. Rated speed is 2300 RPM for this engine, but operation of the engine in the vessel above about 1900 RPM causes the propeller to cavitate, thus, it was not possible to achieve the desired Mode 1 speed. The maximum speed attainable (1860 RPM in Feb. 2006, and 1992 RPM in Nov. 2006) was used for the Mode 2 data point, which had a target speed of 2093 RPM. Actual engine speeds for Modes 3, 4, and 5 closely matched the target speeds. The mode 2 speed was not attainable in November 2014.

Table 6: Planned & Actual Test Cycle (Feb 2006)

Cycle	Mode	Target RPM (% rated speed)	Target Load (% full load)	Target RPM	Actual Avg. RPM
E5	1	100	100	2300	N/A
	2	91	75	2093	1860
	3	80	50	1840	1821
	4	63	25	1449	1444
	5	52	-	1200	1202

N/A – Not Achievable

## Emissions from a Harbor Craft Vessel with Retrofit Control Technologies

Table 7: Planned & Actual Test Cycle (Nov. 2006)

Cycle	Mode	Target RPM (% rated speed)	Target Load (% full load)	Target RPM	Actual Avg. RPM
E5	1	100	100	2300	N/A
	2	91	75	2093	1992
	3	80	50	1840	1840
	4	63	25	1449	1445
	5	52	-	1200	1199

N/A – Not Achievable

The plan for the November 2014 testing was to duplicate the February and November 2006 test cycles as closely as possible. The planned and actual test cycles in November 2014 are presented in Table 8. Because of conditions at the time of testing neither mode 1 nor mode 2 were achievable. The reported RPM's are hand recorded values using a handheld laser tach.

Table 8: Planned & Actual Test Cycle (Nov. 2014)

Cycle	Mode	Target RPM (% rated speed)	Target Load (% full load)	Target RPM	Actual Avg. RPM
E5	1	100	100	2300	N/A
	2	91	75	2093	N/A
	3	80	50	1840	1840
	4	63	25	1449	1450
	5	52	-	1200	1200

N/A – Not Achievable

### Caveats

The emission results, using our best judgement, will be discussed in the next section. The reader should be aware of the following concerns.

1. Because of problems in November 2014 there are no measurements of torque, fuel flow, engine air flow, or any engine temperatures or pressures.
2. In 2014 only a limited number of rpm's were obtained with a handheld laser tach.
3. In 2014 the engine and DPF may have degraded because of poor maintenance.
4. Diesel engines, like the ones in this study, typically have brake specific CO<sub>2</sub> (BSCO<sub>2</sub>) emissions above 500 g/bhp-hr in all operating modes.
  - a. In 2014 the port engine BSCO<sub>2</sub> was below 500 for downstream modes 2 and 3.
  - b. In November 2006 the port engine BSCO<sub>2</sub> was in the high 300's or low 400's for

## Emissions from a Harbor Craft Vessel with Retrofit Control Technologies

- modes 2 and 3 upstream and downstream and the weighted BSCO<sub>2</sub> for the upstream was below 500.
- c. In November 2006 the starboard engine BSCO<sub>2</sub> was below 500 for mode 5.
  - d. In February 2006 the port engine BSCO<sub>2</sub> was in the mid 300's to the low 400's for modes 2 and 3 upstream and downstream.
  - e. In February 2006 the starboard engine BSCO<sub>2</sub> was below 500 for mode 4 and in the low 400's for mode 5.
5. If all environmental conditions were the same for each test then the BSCO<sub>2</sub> should be the same for a given mode but even for the same mode on the same day there is often an appreciable difference between the upstream and downstream BSCO<sub>2</sub> for the port engine.
- a. It is assumed that the speed and direction of ocean and air currents can affect the amount of horsepower required to move the vessel for a given engine rpm.
  - b. Since only one analyzer was available the upstream and downstream emission measurements were made with the vessel traveling in opposite directions.
6. It was noted that some of the filters downstream of the DPF had white flakes on them which may be ash flaking off the DPF and/or the exhaust system.

The statement in 3 above about possible poor maintenance is based upon the following observations by the individual who was setting up the equipment to measure engine torque, fuel flow, engine air flow, etc.

“Regarding the inlet oil. The engine has breather pipes, one on each side of the engine that ventilate the crankcase of the engine. Each pipe feeds into a connection at the base of each air filter. There are two air filters one feeding each turbo air inlet. The crankcase air oil mist is sucked into each filter and what is not filtered out gets mixed with the intake air and goes into the engine via each turbo.”

“(Note: attached photo 0017, shows the clear tubing attached to the breather cap on the top of the cover over the injectors). This is the test set up. In the normal (not test) engine operating configuration, another hose would replace the plastic tube and go directly to the air filter housing which would be attached to a turbo inlet via a rubber connection. Photo 0018 shows the rest of the test set up, the long annubar tube, the clear plastic tube connected to a long piece of pvc pipe and another clear tube from the pvc pipe to the breather connection on the filter, the filter connected now to the tee at the end of the annubar tube. Note: under the filter housing is a yellowish tan hose that is supposed to drain excess breather oil, out of the air filter housing.”

“For our test set up, we removed the air filters from each turbo,” used a Y tube to connect the turbo inlets together and mate them “with our annubar air meter tube. We then attached a tee to the inlet of the air meter tube and mounted one filter on each branch of the tee. When we did this, we found both filters were dripping with oil, and it made quite a mess on the deck. We had one of the mechanics remove the filters, clean out the housings and install new air filters.”

“My conclusion was (1) I don't think filters had been replaced recently and (2) there was probably a considerable amount of "blow by", i.e. pressurizing the sump by combustion

## Emissions from a Harbor Craft Vessel with Retrofit Control Technologies

gases blowing by worn piston rings, carrying a fair amount of oil via the breather pipes into the engine. This would certainly cause more particulate, but I don't know if it would explain, by itself, the increase you observed. Unfortunately, we don't have a record of how much oil they have to add on a per hour operating hour basis.”

“I also noticed, the engine room was in rather sorry shape. There was an overhead fuel line with a leak, dripping down near the battery rack for the generators. The leak was being managed by wrapping a rag around it, with the rag hanging down, which acted to at least localize the trajectory of the leak. The pneumatic starter exhaust had oil dripping out of it, with absorbent pads under it. The engine driven sea water pump could not reliably pull a suction. The above would not directly point to increased particulate readings, but are indicative of a general lack of maintenance. So, one might conclude, without having the benefit of maintenance logs, that the increased particulate could be due to the wear and tear of the operation, (10K hours?) combined with less than adequate maintenance.”



Photo 0017

## Emissions from a Harbor Craft Vessel with Retrofit Control Technologies



Photo 0018

### Emissions Results and Discussion (November 2014)

Emissions of  $\text{NO}_x$ , CO,  $\text{CO}_2$ , PM, EC, OC were measured over the same operating modes at two locations: 1) engine out (upstream of Rypos active DPF) exhaust from the CCTS-equipped port engine, and 2) downstream of the Rypos active DPF in the exhaust of the CCTS-equipped port engine. Data is measured in triplicate, with average values and standard deviation error bars shown in the following plots and tables. Because of problems during the testing some of the emissions were only valid for two of the triplicate runs and in those cases the averages and the standard deviations are for the duplicates. Table 9 contains the average engine emissions data from modes 2, 3, 4, 5 and weighted for the three testing programs. The emissions for all three programs are plotted in Figure 5 through Figure 10, the fuel consumption in Figure 11 and the OC/EC ratios in Figure 12 and Figure 13. In the tables and figures that follow F2006 is for February 2006, N2006 is for November 2006, and N2014 is for November 2014. The mode 2 emissions for the November 2014 data are estimated by multiplying the mode 3 emissions in g/hr by the average ratio of the mode 2 to mode 3 emissions in g/hr of the February and November 2006 data since it was not possible to achieve mode 2 conditions during the testing. The weighted emissions are calculated using weighting factors of 0.21 for mode 2 (sum of mode 1 and mode 2 weighting factors for E5 cycle), 0.17 for mode 3, 0.32 for mode 4, and 0.30 for mode 5. Note that in Figure 5 the starboard  $\text{NO}_x$  emissions are divided by 3 and in Figure 6 the starboard CO emissions are divided by 2.

The navy personnel had a new system and software for measuring torque, fuel flow, air flow into the engine, etc. and did not get the software properly configured so no torque data or air flow into the engine was obtained and thus horsepower and exhaust flow rate

## Emissions from a Harbor Craft Vessel with Retrofit Control Technologies

could not be calculated. Plots of the combined February and November 2006 port engine downstream and upstream data showed linear correlations between bhp and rpm and between scfm and rpm. Using all the modal data the linear equations are:

$$\text{bhp} = 0.3644(\text{rpm}) - 370.54 \text{ with } R^2 = 0.9692.$$

$$\text{scfm} = 0.468(\text{rpm}) - 24.221 \text{ with } R^2 = 0.9937.$$

Because mode 2 was not achievable for the November 2014 testing we also determined these equations using only the mode 3 through 5 data which gives the following equations (See :

$$\text{bhp} = 0.3448(\text{rpm}) - 344.92 \text{ with } R^2 = 0.9549.$$

$$\text{scfm} = 0.4621(\text{rpm}) - 16.73 \text{ with } R^2 = 0.9922$$

The latter equations were used to estimate the bhp and scfm for the November 2014 data.

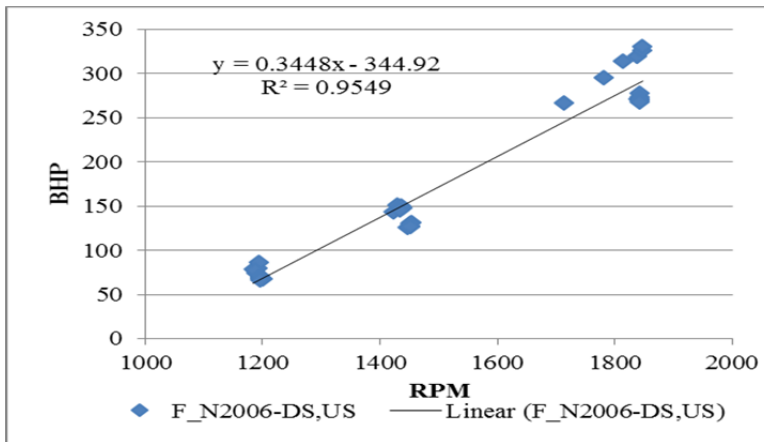

Figure 4: Brake Horsepower Versus rpm for Port Engine Modes 3, 4, 5 Upstream and Downstream of the DPF

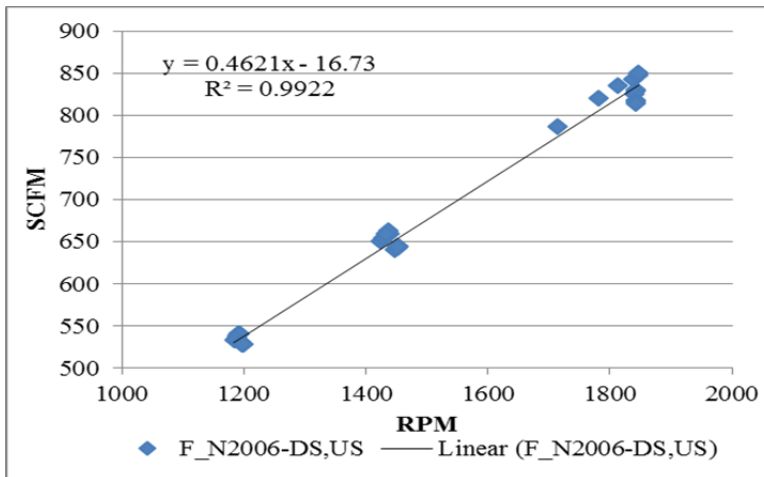

Figure 5: Exhaust SCFM Versus rpm for Port Engine Modes 3, 4, 5 Upstream and Downstream of the DPF

## Emissions from a Harbor Craft Vessel with Retrofit Control Technologies

*Table 9: Emissions and Fuel Consumption for the three testing programs*

		Average Emissions (g/bhp-hr)																		kg/bhp-hr		
		NO <sub>x</sub>			CO			CO <sub>2</sub>			PM			EC			OC			Fuel Consumption		
Mode	Date	STA	UPS	DNS	STA	UPS	DNS	STA	UPS	DNS	STA	UPS	DNS	STA	UPS	DNS	STA	UPS	DNS	STA	UPS	DNS
2	F2006	13.58	3.14	2.94	5.00	0.99	0.74	529	416	359	0.299	0.185	0.037	0.034	0.047	0.009	0.250	0.080	0.029	0.204	0.154	0.133
	N2006	10.70	3.33	3.92	3.55	0.45	0.65	524	377	430	0.262	0.096	0.036	0.031	0.042	0.015	0.227	0.072	0.050	0.163	0.124	0.141
	N2014		4.53	4.43		0.82	0.99		552	487		1.791	0.406		0.044	0.079		0.762	0.189		0.174	0.153
3	F2006	14.15	3.33	2.96	5.06	0.98	0.80	535	411	369	0.194	0.112	0.030	0.042	0.047	0.008	0.171	0.064	0.021	0.206	0.152	0.137
	N2006	10.60	2.95	3.15	1.29	0.46	0.54	535	404	397	0.248	0.064	0.025	0.047	0.048	0.015	0.188	0.065	0.040	0.165	0.133	0.131
	N2014		4.28	3.84		0.81	0.92		570	471		1.166	0.306		0.046	0.072		0.605	0.140		0.179	0.148
4	F2006	13.79	3.56	3.84	0.73	2.04	1.33	483	538	528	0.150	0.340	0.087	0.015	0.082	0.023	0.156	0.253	0.067	0.184	0.204	0.200
	N2006	10.16	3.71	3.34	0.78	0.84	0.92	542	568	564	0.156	0.105	0.047	0.017	0.100	0.038	0.177	0.318	0.106	0.167	0.187	0.186
	N2014		2.85	3.05		0.57	0.60		520	532		0.403	0.137		0.062	0.050		0.295	0.052		0.163	0.167
5	F2006	12.59	4.86	4.92	0.95	1.62	1.65	435	604	598	0.118	0.126	0.048	0.013	0.052	0.015	0.119	0.109	0.055	0.166	0.229	0.226
	N2006	9.04	4.03	4.17	1.03	1.48	1.43	494	703	708	0.157	0.181	0.064	0.016	0.083	0.027	0.148	0.185	0.089	0.153	0.232	0.233
	N2014		4.47	5.05		1.25	1.38		752	821		0.288	0.183		0.065	0.061		0.155	0.088		0.236	0.258
Weighted	F2006	9.66	2.96	2.87	4.19	1.66	1.27	609	557	513	0.251	0.209	0.052	0.028	0.056	0.013	0.184	0.122	0.037	0.193	0.173	0.168
	N2006	9.89	3.40	3.64	2.36	0.74	0.87	517	486	506	0.226	0.099	0.038	0.030	0.062	0.021	0.196	0.143	0.066	0.163	0.153	0.159
	N2014		3.73	3.98		0.74	0.91		527	531		1.029	0.286		0.048	0.062		0.496	0.087		0.166	0.152



## Emissions from a Harbor Craft Vessel with Retrofit Control Technologies

Standard Deviation (g/bhp-hr)																		SD (kg/bhp-hr)		
NOx			CO			CO2			PM			EC			OC			Fuel Consumption		
STA	UPS	DNS	STA	UPS	DNS	STA	UPS	DNS	STA	UPS	DNS	STA	UPS	DNS	STA	UPS	DNS	STA	UPS	DNS
0.09	0.01	0.07	0.16	0.06	0.05	3.2	3.4	7.4	0.062	0.029	0.003	0.004	0.000	0.001	0.025	0.004	0.002	0.0013	0.0013	0.0028
0.04	0.07	0.34	0.31	0.01	0.06	3.4	12.6	40.6	0.004	0.020	0.002	0.003	0.004	0.011	0.025	0.004	0.036	0.0012	0.0042	0.0134
	0.11	0.05		0.02	0.16		2.6	3.7		0.453	0.074		0.004	0.002		0.164	0.044		0.0008	0.0012
0.32	0.05	0.09	0.08	0.15	0.05	11.3	2.2	12.5	0.011	0.012	0.005	0.007	0.008	0.001	0.000	0.008	0.001	0.0043	0.0009	0.0046
0.16	0.01	0.02	0.03	0.02	0.02	3.4	5.0	12.7	0.007	0.007	0.003	0.008	0.011	0.010	0.002	0.014	0.021	0.0010	0.0016	0.0042
	0.11	0.04		0.02	0.15		2.7	3.6		0.295	0.056		0.004	0.002		0.130	0.033		0.0009	0.0012
0.84	0.24	0.27	0.05	0.31	0.04	23.1	41.6	34.6	0.024	0.082	0.015	0.002	0.013	0.005	0.020	0.071	0.005	0.0088	0.0159	0.0131
0.49	0.02	0.11	0.01	0.02	0.06	11.8	13.6	25.8	0.017	0.025	0.003	0.002	0.016	0.026	0.024	0.139	0.052	0.0036	0.0045	0.0085
	0.06	0.03		0.01	0.01		10.8	6.6		0.048	0.006		0.004	0.001		0.074	0.009		0.0034	0.0021
1.06	0.20	0.27	0.08	0.06	0.07	31.7	25.0	30.5	0.005	0.009	0.003	0.001	0.006	0.002	0.005	0.012	0.004	0.0121	0.0095	0.0115
0.29	0.15	0.06	0.03	0.05	0.16	13.2	22.3	2.1	0.008	0.000	0.006	0.001	0.035	0.016	0.017	0.115	0.040	0.0041	0.0073	0.0008
	0.13	0.05		0.05	0.02		10.1	9.9		0.013	0.020		0.004	0.007		0.030	0.006		0.0032	0.0031
0.36	0.05	0.09	0.18	0.06	0.01	19.0	9.9	12.4	0.016	0.009	0.001	0.001	0.004	0.001	0.005	0.015	0.004	0.0061	0.0106	0.0083
0.15	0.02	0.17	0.15	0.01	0.06	2.6	9.0	25.8	0.005	0.001	0.001	0.002	0.002	0.014	0.004	0.035	0.033	0.0007	0.0028	0.0081
	0.07	0.01		0.02	0.07		1.5	3.3		0.218	0.028		0.002	0.010		0.074	0.075		0.0005	0.0258

# Emissions from a Harbor Craft Vessel with Retrofit Control Technologies

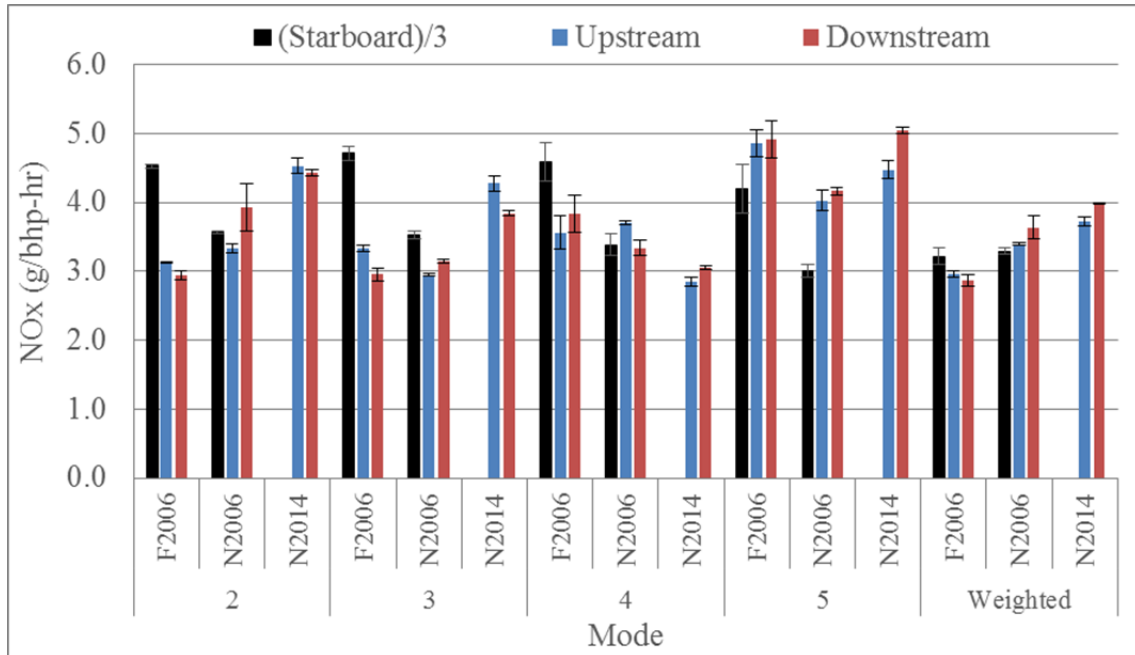

Figure 5: Modal and Weighted NOx Emission Factors

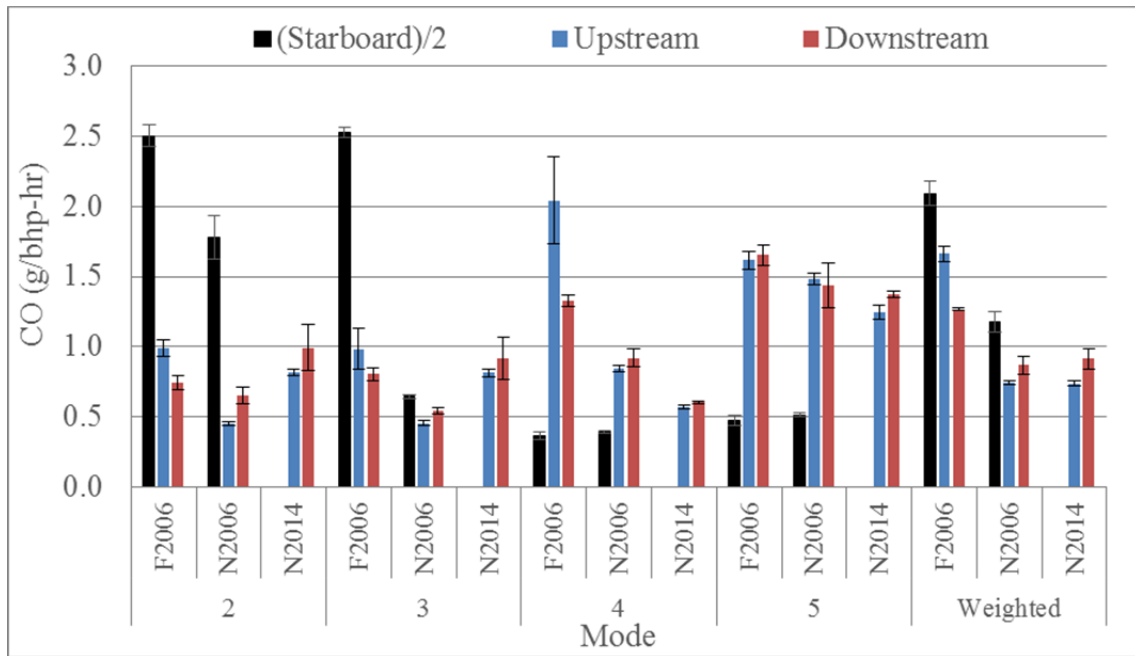

Figure 6: Modal and Weighted CO Emission Factors

# Emissions from a Harbor Craft Vessel with Retrofit Control Technologies

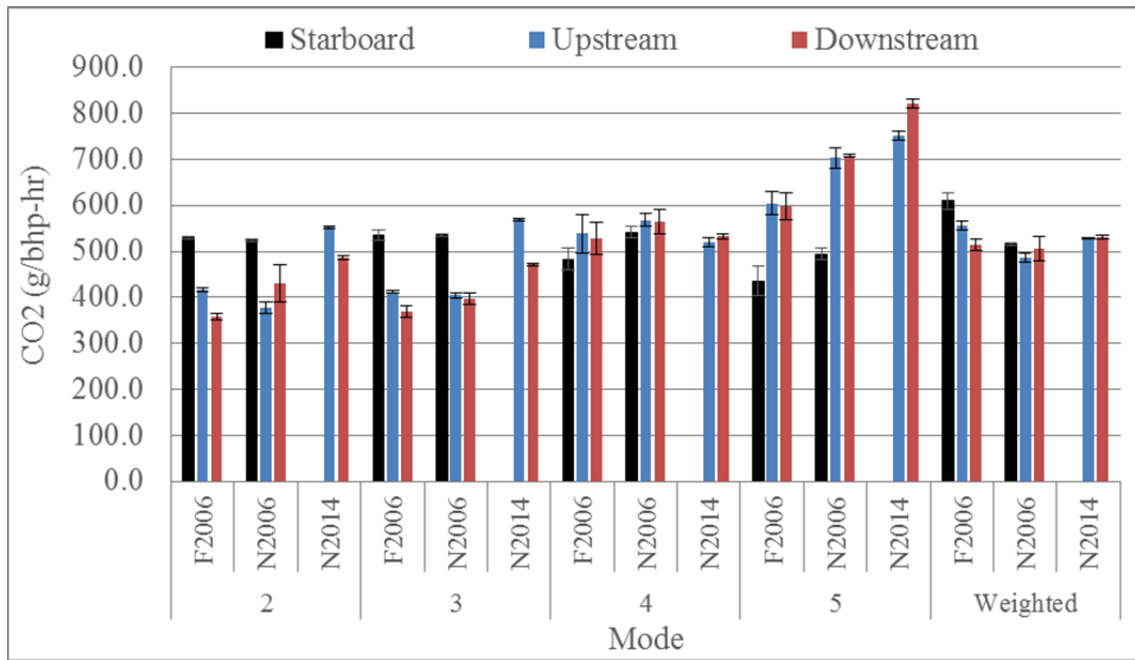

Figure 7: Modal and Weighted CO<sub>2</sub> Emission Factors

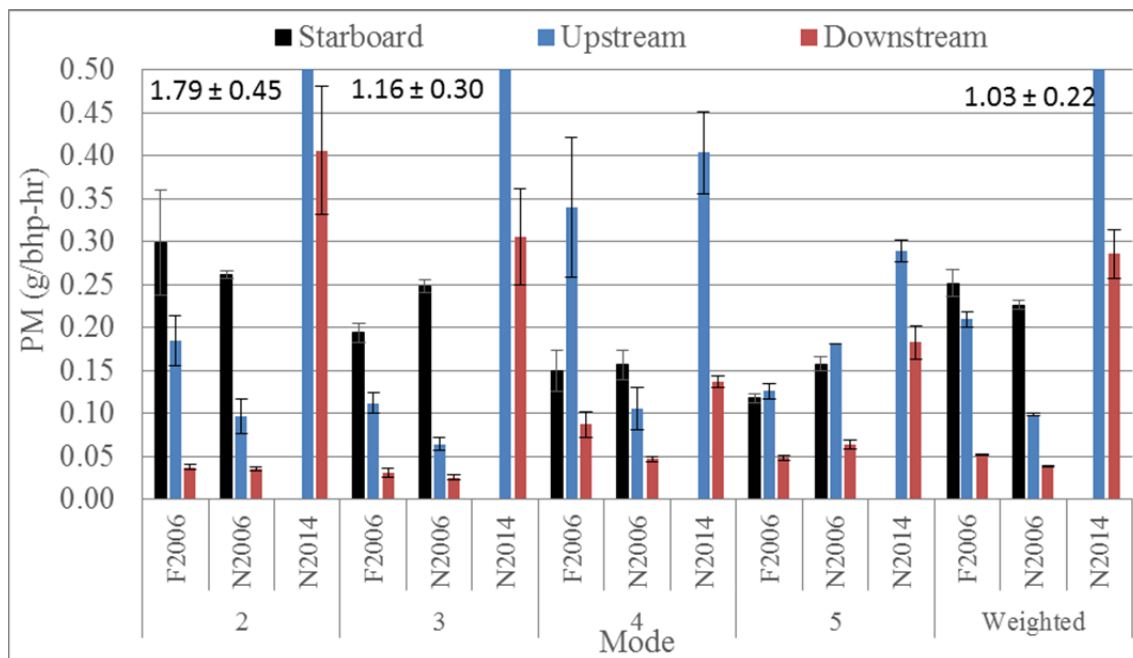

Figure 8: Modal and Weighted PM Emission Factors

## Emissions from a Harbor Craft Vessel with Retrofit Control Technologies

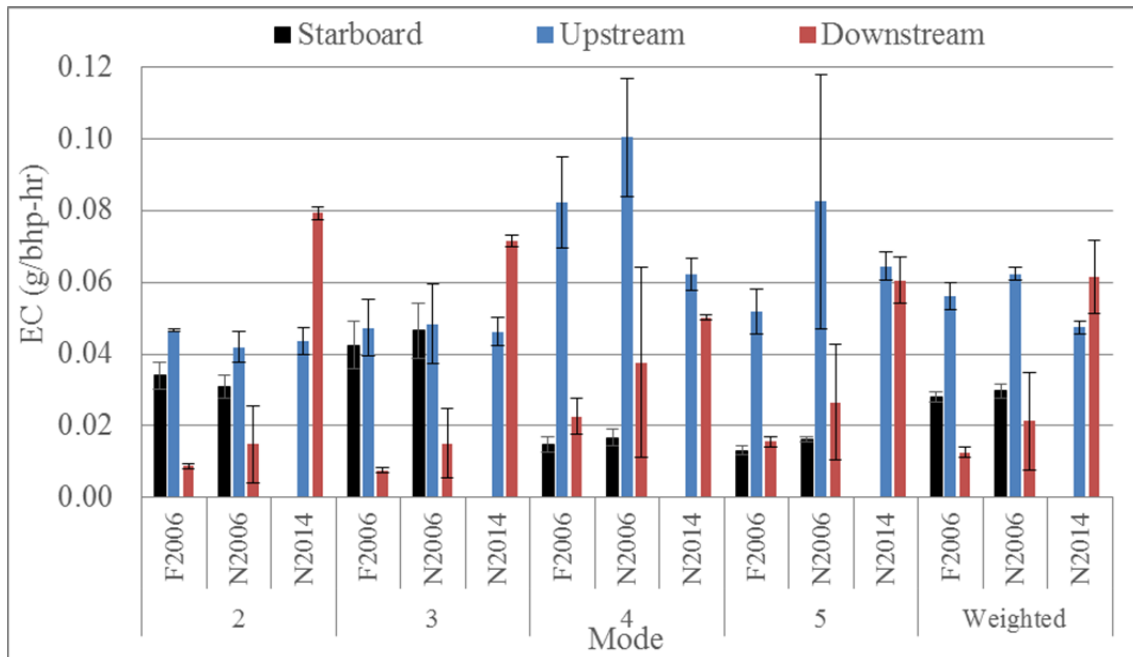

Figure 9: Modal and Weighted EC Emission Factors

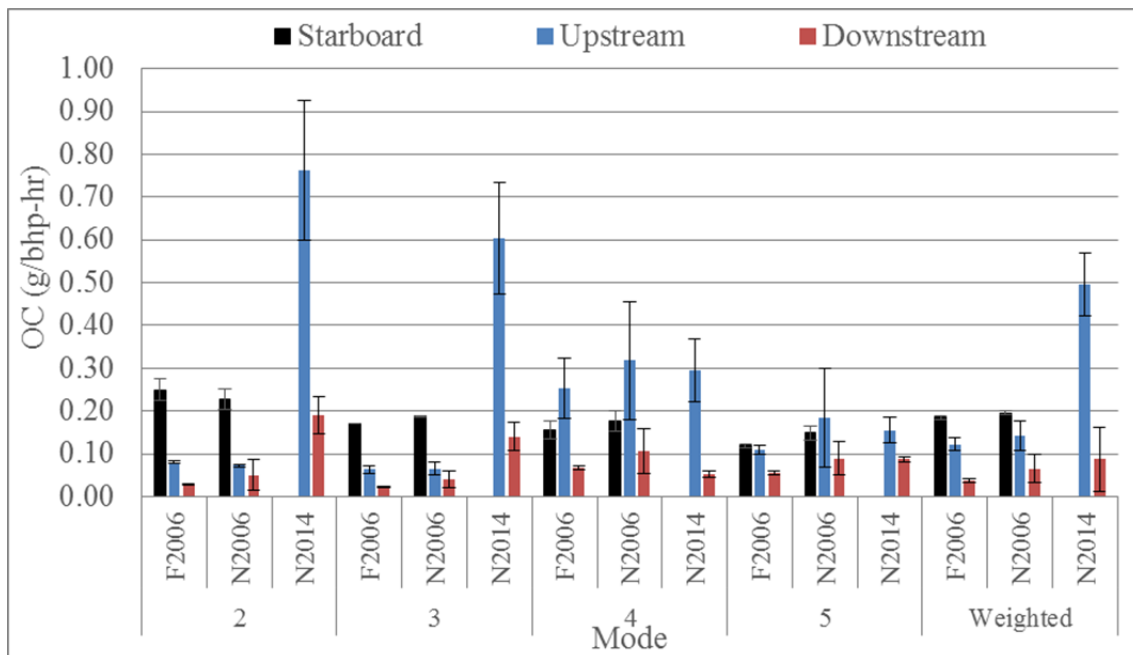

Figure 10: Modal and Weighted OC Emission Factors

Comparison of the upstream emissions of the port engine with the emissions of the uncontrolled starboard emissions provides an estimate of the control efficiency of the CCTS technology. Comparison of the port engine downstream emissions with the port engine upstream emissions provides an estimate of the control efficiency of the Rypos DPF. The CCTS technology is primarily designed to control  $\text{NO}_x$  and CO emissions while the Rypos DPF controls particulate emissions (PM EC, OC). The primary purpose of the November 2014 testing was to compare the efficiency of these two control technologies in November 2014 and February 2006 to determine

## Emissions from a Harbor Craft Vessel with Retrofit Control Technologies

degradation in efficiency over the ~9 years of operation. The emissions and % reduction of emissions by the CCTS control technology is summarized in Table 10 and the emissions and % reduction of emissions by the Rypos DPF control technology is summarized in Table 11.

On a modal basis the NO<sub>x</sub> control efficiency is 10.3 and 6.7% worse in November 2014 versus February 2006 for modes 2 and 3, respectively, and is 5.1 and 3.1% better for modes 4 and 5, respectively. (If the difference between the %reduction in November 2014 and the % reduction in 2006 is negative it is considered %worse, if it is positive it is considered %better) On a weighted basis the NO<sub>x</sub> control efficiency is 8.0% worse in November 2014 versus February 2006. On a modal basis the CO control efficiency is 3.4, 3.4, 201, and 39% better in November 2014 versus February 2006 for modes 2, 3, 4, and 5, respectively. On a weighted basis the CO control efficiency is 22 % better in November 2014 versus February 2006.

On a modal basis the PM control efficiency is 2.5, -0.7, 8.2, and 25% worse in November 2014 versus February 2006 for modes 2, 3, 4 and 5, respectively. On a weighted basis the PM control efficiency is 3.0% worse in November 2014 versus February 2006. On a modal basis the EC control efficiency is 163, 139, 53, and 64% worse in November 2014 versus February 2006 for modes 2, 3, 4, and 5, respectively. On a weighted basis the EC control efficiency is 107 % worse in November 2014 versus February 2006. On a modal basis the OC control efficiency is 12, 10, 9, and -7% better in November 2014 versus February 2006 for modes 2, 3, 4, and 5, respectively. On a weighted basis the OC control efficiency is 13 % better in November 2014 versus February 2006.

*Table 10: Emissions and %Reductions in February 2006 and November 2014 by CCTS*

	Emissions (g/bhp-hr)									
	February 2006				November 2014		% Reduction by CCTS			
	Starboard		Port Upstream		Port Upstream		February 2006		November 2014	
	Mode	NO <sub>x</sub>	CO	NO <sub>x</sub>	CO	NO <sub>x</sub>	CO	NO <sub>x</sub>	CO	NO <sub>x</sub>
2	13.58	5.00	3.14	0.99	4.53	0.82	<b>76.9</b>	<b>80.3</b>	<b>66.6</b>	<b>83.7</b>
3	14.15	5.06	3.33	0.98	4.28	0.81	<b>76.5</b>	<b>80.5</b>	<b>69.8</b>	<b>83.9</b>
4	13.79	0.73	3.56	2.04	2.85	0.57	<b>74.2</b>	<b>-178.5</b>	<b>79.3</b>	<b>22.4</b>
5	12.59	0.95	4.86	1.62	4.47	1.25	<b>61.4</b>	<b>-69.9</b>	<b>64.5</b>	<b>-30.9</b>
Weighted	9.66	4.19	2.96	1.66	3.73	0.74	<b>69.4</b>	<b>60.3</b>	<b>61.4</b>	<b>82.4</b>

*Table 11: Emissions and %Reductions in February 2006 and November 2014 by Rypos DPF*

Emissions (g/bhp-hr)																	
Port Engine - February 2006						Port Engine - November 2014						%Reduction by Rypos					
PM		EC		OC		PM		EC		OC		February 2006		November 2014			
UPS	DNS	UPS	DNS	UPS	DNS	UPS	DNS	UPS	DNS	UPS	DNS	PM	EC	OC	PM	EC	OC
0.185	0.037	0.047	0.009	0.080	0.029	1.791	0.406	0.044	0.079	0.762	0.189	<b>79.8</b>	<b>81.4</b>	<b>63.4</b>	<b>77.3</b>	<b>-81.3</b>	<b>75.2</b>
0.112	0.030	0.047	0.008	0.064	0.021	1.166	0.306	0.046	0.072	0.605	0.140	<b>73.0</b>	<b>84.0</b>	<b>66.7</b>	<b>73.7</b>	<b>-54.8</b>	<b>76.9</b>
0.340	0.087	0.082	0.023	0.253	0.067	0.403	0.137	0.062	0.050	0.295	0.052	<b>74.3</b>	<b>72.6</b>	<b>73.3</b>	<b>66.2</b>	<b>19.6</b>	<b>82.3</b>
0.126	0.048	0.052	0.015	0.109	0.055	0.288	0.183	0.065	0.061	0.155	0.088	<b>61.6</b>	<b>70.2</b>	<b>49.8</b>	<b>36.7</b>	<b>6.1</b>	<b>43.3</b>
0.209	0.052	0.056	0.013	0.122	0.037	1.029	0.286	0.048	0.062	0.496	0.087	<b>75.2</b>	<b>77.8</b>	<b>69.7</b>	<b>72.2</b>	<b>-29.5</b>	<b>82.4</b>

## Emissions from a Harbor Craft Vessel with Retrofit Control Technologies

The discussion above, relative to Table 10, compares the February 2006 starboard engine emissions to the February 2006 and November 2014 port engine upstream emissions while Table 11 compares the downstream and upstream port engine emissions in February 2006 and November 2014. Table 12 presents the average of the February and November 2006 (average 2006) starboard engine emissions and the November 2014 port engine upstream emissions of NO and CO and the %reduction by the CCTS technology.

On a modal basis the NO<sub>x</sub> control efficiency is 10.7, 9.2, and 0.2% worse in November 2014 versus average 2006 for modes 2, 3, and 5, respectively, and is 6.5% better for mode 4. On a weighted basis the NO<sub>x</sub> control efficiency is 5.6% worse in November 2014 versus average 2006. On a modal basis the CO control efficiency is 2.2 and 2.9% worse in November 2014 versus average 2006 for modes 2 and 3, respectively, while it is 115 and 31% better for modes 4 and 5. On a weighted basis the CO control efficiency is 14 % better in November 2014 versus average 2006. Based on these comparisons, and the comparisons to the February 2006 data in Table 10, there has been some degradation of the CCTS NO<sub>x</sub> control efficiency, but some improvement in the CO control efficiency.

*Table 12: Emissions and %Reductions by CCTS based on average of (February 2006 and November2006) and November 2014*

	Emissions (g/bhp-hr)									
	Ave(Feb,Nov)2006				November 2014		% Reduction by CCTS			
	Starboard		Port Upstream		Port Upstream		Ave(Feb,Nov)2006		November 2014	
Mode	NOx	CO	NOx	CO	NOx	CO	NOx	CO	NOx	CO
2	12.14	4.28	3.23	0.72	4.53	0.82	<b>73.4</b>	<b>83.2</b>	<b>62.6</b>	<b>80.9</b>
3	12.38	3.17	3.14	0.72	4.28	0.81	<b>74.6</b>	<b>77.3</b>	<b>65.4</b>	<b>74.4</b>
4	11.97	0.76	3.63	1.44	2.85	0.57	<b>69.6</b>	<b>-90.5</b>	<b>76.2</b>	<b>24.9</b>
5	10.82	0.99	4.45	1.55	4.47	1.25	<b>58.9</b>	<b>-56.7</b>	<b>58.6</b>	<b>-25.9</b>
Weighted	9.77	3.27	3.18	1.20	3.73	0.74	<b>67.5</b>	<b>63.3</b>	<b>61.9</b>	<b>77.5</b>

As is evident from Figure 7, as expected, there is no significant effect from either the CCTS or the Rypos DPF technology on the CO<sub>2</sub> emissions.

The average of the February and November 2006 port engine upstream PM, EC, and OC data and the average of the February and November 2006 port engine downstream PM, EC, and OC data is presented in Table 13 along with the November 2014 port engine upstream and downstream PM, EC, and OC data. The %reduction of these emissions for 2006 and 2014 are also shown.

On a modal basis the PM control efficiency is 3.4 and 5.3% better for modes 2 and 3, respectively, in November 2014 versus in 2006 and it is 3.8 and 27% worse in November 2014 for modes 4 and 5, respectively versus in 2006. On a weighted basis the PM control efficiency is 1.5% better in November 2014 versus 2006. On a modal basis the EC control efficiency is 155, 131, 48, and 63% worse in November 2014 versus 2006 for modes 2, 3, 4, and 5, respectively. On a weighted basis the EC control efficiency is 101 % worse in November 2014 versus 2006. On a modal basis the OC control efficiency is 27, 25, and 13% better in November 2014 versus 2006

## Emissions from a Harbor Craft Vessel with Retrofit Control Technologies

for modes 2, 3, and 4, respectively and it is -7.6% worse for mode 5. On a weighted basis the OC control efficiency is 21 % better in November 2014 versus 2006. Within the limits of the data there does not appear to be any reduction in the %efficiency of the Rypos DPF for reducing PM, EC, or OC. However, the absolute emissions of these particulates has increased because of an increase in the upstream emissions of PM and OC. The upstream modal emissions of PM for modes 2, 3, 4, and 5, respectively, in November 2014 are 12.8, 13.3, 1.8 and 1.9 times higher than in 2006 and the weighted emissions are 6.7 times higher. The downstream modal emissions of PM for modes 2, 3, 4, and 5, respectively, in November 2014 are 11.1, 11.1, 2.0 and 3.3 times higher than in 2006 and the weighted emissions are 6.3 times higher. The upstream modal emissions of EC for modes 2, 3, 4, and 5, respectively, in November 2014 are 0.99, 0.97, 0.68, and 0.96 times higher than in 2006 and the weighted emissions are 0.8 times higher. The downstream modal emissions of EC for modes 2, 3, 4, and 5, respectively, in November 2014 are 6.8, 6.3, 1.7, and 2.9 times higher than in 2006 and the weighted emissions are 3.6 times higher. The upstream modal emissions of OC for modes 2, 3, 4, and 5, respectively, in November 2014 are 10, 9.4, 1.0 and 1.1 times higher than in 2006 and the weighted emissions are 3.7 times higher. The downstream modal emissions of OC for modes 2, 3, 4, and 5, respectively, in November 2014 are 4.8, 4.5, 0.6, and 1.2 times higher than in 2006 and the weighted emissions are 1.7 times higher.

*Table 13: Emissions and %Reductions by Rypos DPF based on average of (February 2006 and November 2006) and November 2014*

Emissions (g/bhp-hr)																	
Port Engine - Ave(Feb,Nov)2006						Port Engine - November 2014						%Reduction by Rypos					
PM		EC		OC		PM		EC		OC		Ave(Feb,Nov)2006		November 2014			
UPS	DNS	UPS	DNS	UPS	DNS	UPS	DNS	UPS	DNS	UPS	DNS	PM	EC	OC	PM	EC	OC
0.140	0.037	0.044	0.012	0.076	0.040	1.791	0.406	0.044	0.079	0.762	0.189	<b>73.9</b>	<b>73.6</b>	<b>48.0</b>	<b>77.3</b>	<b>-81.3</b>	<b>75.2</b>
0.088	0.028	0.048	0.011	0.065	0.031	1.166	0.306	0.046	0.072	0.605	0.140	<b>68.5</b>	<b>76.3</b>	<b>52.3</b>	<b>73.7</b>	<b>-54.8</b>	<b>76.9</b>
0.223	0.067	0.091	0.030	0.285	0.087	0.403	0.137	0.062	0.050	0.295	0.052	<b>69.9</b>	<b>67.0</b>	<b>69.6</b>	<b>66.2</b>	<b>19.6</b>	<b>82.3</b>
0.154	0.056	0.067	0.021	0.147	0.072	0.288	0.183	0.065	0.061	0.155	0.088	<b>63.6</b>	<b>68.7</b>	<b>51.0</b>	<b>36.7</b>	<b>6.1</b>	<b>43.3</b>
0.154	0.045	0.059	0.017	0.132	0.051	1.029	0.286	0.048	0.062	0.496	0.087	<b>70.7</b>	<b>71.5</b>	<b>61.2</b>	<b>72.2</b>	<b>-29.5</b>	<b>82.4</b>

The fuel consumption was determined by the carbon balance method. Figure 11 shows the fuel consumption by mode and the weighted values. The numbers above each group of boxes are the percentage differences between fuel consumption of the starboard and port engine. The modal percentage difference between the starboard and the port engine range from -38.1 to 26.1 % in February 2006 with a weighted average of 10.5%. The modal percentage difference between the starboard and the port engine ranged from -51.8 to 23.9 % in November 2006 with a weighted average of 6.4%. The modal percentage difference between the starboard and the port engine ranged from -48.5 to 6.9 % in November 2014 with a weighted average of 7.0%. No solid conclusion can be drawn from this data as to whether there has been a significant change in the fuel consumption.

## Emissions from a Harbor Craft Vessel with Retrofit Control Technologies

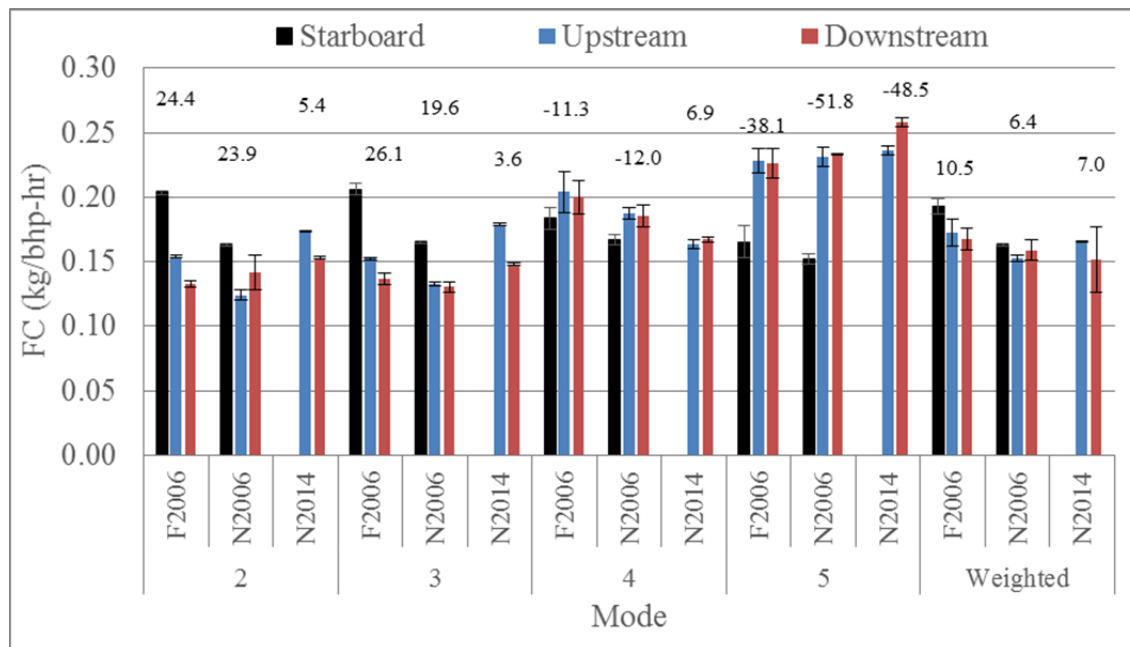

Figure 11: Modal and Weighted Fuel Consumption Factors

The ratio of organic carbon (OC) to elemental carbon (EC) is shown in Figure 12 for upstream of the DPF and in Figure 13 for downstream of the DPF. In February and November 2006 the ratio is relatively constant across the modes for both the upstream and downstream data. In November 2014 there was a sharp decrease in the ratio going from the high to the low speeds for the upstream data. For the November 2014 downstream data the ratio decreased from the high to the low speeds but at a slower rate. The higher output of organic carbon, may be because of “blow by” lube oil from the crankcase being ventilated into the air before the turbochargers.

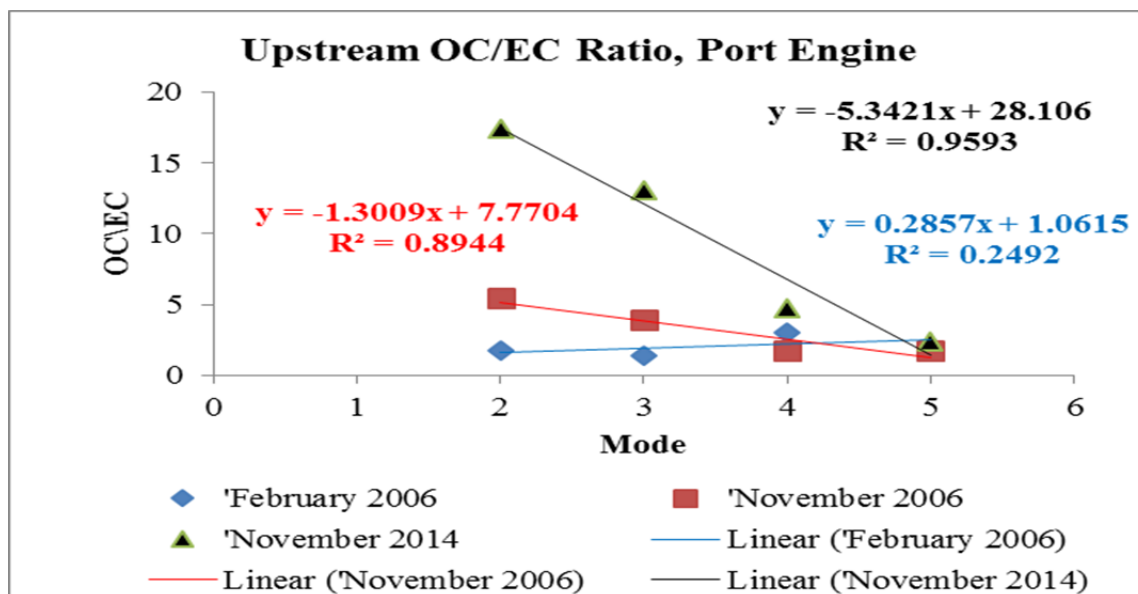

Figure 12: Upstream OC/EC Ratio, Port Engine



## Emissions from a Harbor Craft Vessel with Retrofit Control Technologies

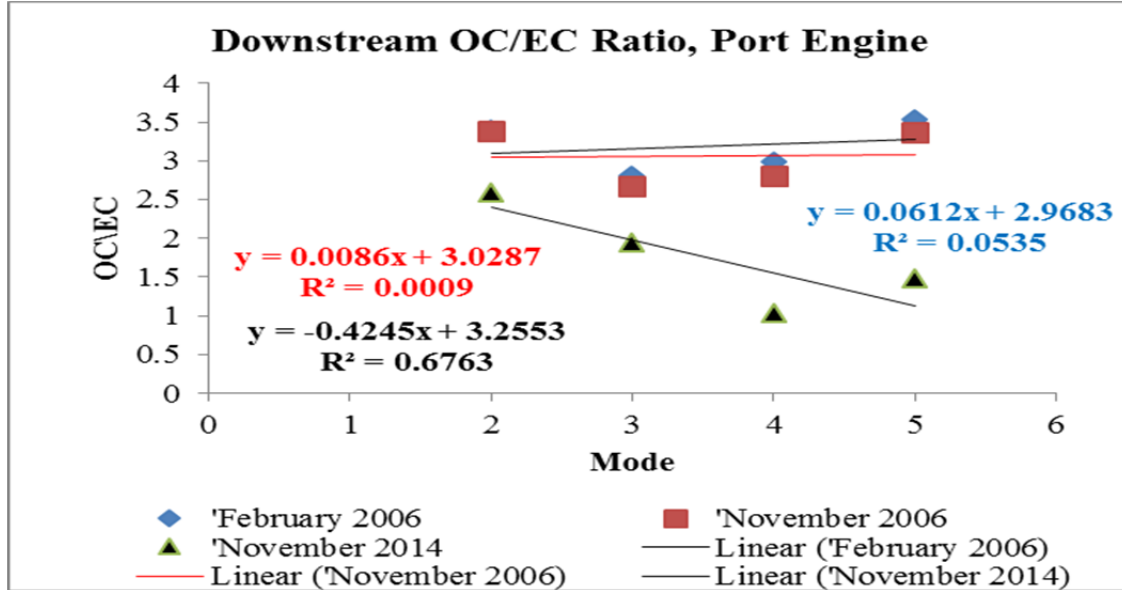

Figure 13: Downstream OC/EC Ratio, Port Engine

As was noted in the “Measuring the Gaseous Emissions” section the Horiba PG-250 measures SO<sub>2</sub> concentrations. Since our gaseous calibration mixtures only contain CO, CO<sub>2</sub>, and NO<sub>x</sub> the SO<sub>2</sub> results are not quantitative. However for these three programs they should provide a qualitative indication of the level of SO<sub>2</sub>. **Error! Reference source not found.** presents the modal and weighted SO<sub>2</sub> emissions for all three programs. Several bars are missing for the November 2006 data. Examination of the data that would be included in those bars revealed that the SO<sub>2</sub> detector was not operating properly as most results were negative, zero, or very high. Qualitatively, for the February and November 2006 data, the SO<sub>2</sub> emissions are essentially the same for all modes for the starboard and port engine. For the November 2014 data the SO<sub>2</sub> emissions are higher than the SO<sub>2</sub> emissions from the port engine in February and November 2006. This result is consistent with lube oil, which contains sulfur, being ingested into the engine combustion chamber.

## Emissions from a Harbor Craft Vessel with Retrofit Control Technologies

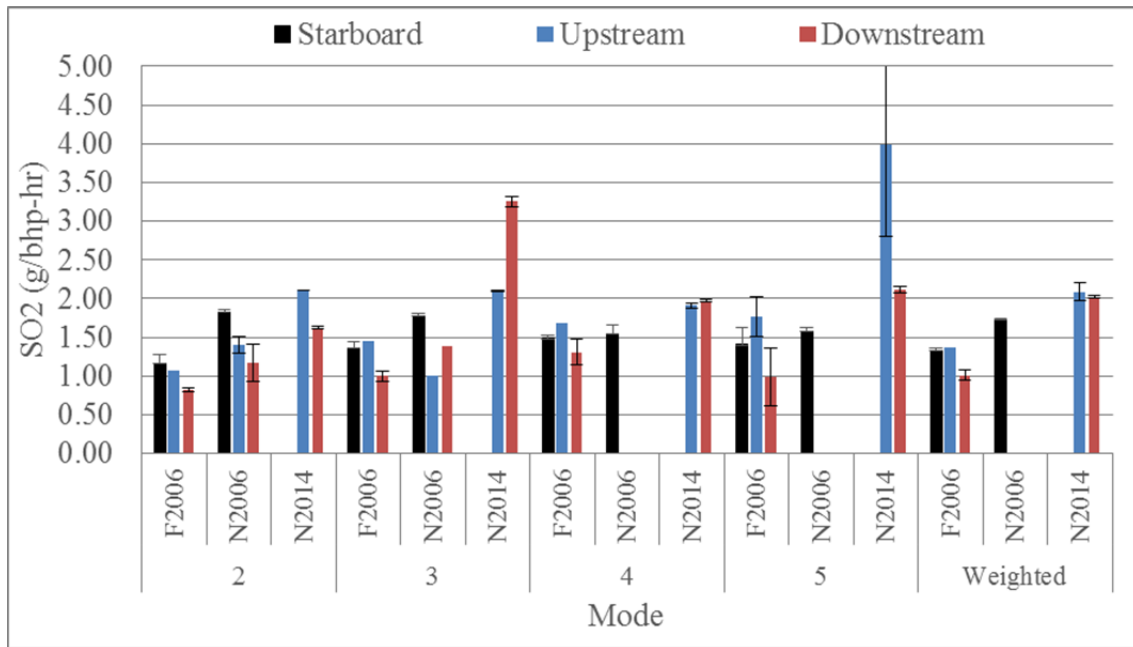

Figure 14: Modal and Weighted Approximate SO2 Emissions

# **Emissions from a Harbor Craft Vessel with Retrofit Control Technologies**

## **Summary and Conclusions**

The main objective of this project was to determine if the emissions from the port engine are still essentially the same after nine plus years of in-service operation. The data indicate that the percent efficiency of the NO<sub>x</sub> control may be somewhat worse than when the engine was placed in service. This may be more a reflection of improper maintenance of the engine than deterioration of the CTTS. The PM control efficiency appears to be still essentially the same, but the overall PM emissions are higher. This result is consistent with lack of proper maintenance of the engine. The qualitative results for SO<sub>2</sub> are also consistent with lack of proper maintenance of the engine as they indicate that ‘by pass’ lube oil is entering the air stream in front of the turbo’s.

The inability to achieve the engine speed required for measurement of mode 2 emissions indicates that the engine may not be able to produce the higher horsepower settings that it could when it was newly rebuilt.

# Emissions from a Harbor Craft Vessel with Retrofit Control Technologies

## APPENDIX A TEST FUEL PROPERTIES



Naval Air Systems Command, AIR 4.4.5

### Fuels Analyses Summary

Dates of Test Reports			9 Aug 2004	3 Mar 2006	16 Apr 2007	20 Nov 2014
Characteristic	F-76 Requirement	ASTM Test Method	F-76 (lab test)*	F-76/MGO (shipboard test)*	F-76/MGO (shipboard test)*	F-76/MGO (shipboard test)**
Acid Number	0.30 mg KOH/g max	D 974	0.060	0.0391 / 0.0442	0.05	0.06
Appearance @ 25 °C	Clear, bright and free of visible particulates	D 4176	Clear & bright	Clear & bright; vis. part. (fail)	Clear & bright, no vis. part.	Clear & bright (fail), vis. part. (fail)
Total Aromatics***	No spec. limit	D 6379% wt.	26.2	47.34	42.3	37.13
Aromatics, Dicyclic***	No spec. limit	D 6379% wt.	4.6	16.32	15.7	18.06
Aromatics, Monocyclic***	No spec. limit	D 6379% wt.	21.6	31.02	26.6	19.1
Ash	0.005 wt% max	D 482	<0.001	<0.001	<0.001	0.003
Carbon Residue (Ramsbottom 10% bottoms)	0.20 wt% max	D 524	0.14	0.27	0.28	0.06
Cetane Index	43 min	D 976	50.5	48.8	47.7	46.5
Cloud Point	-1 °C max	D 2500	-11.1	-5.2	-6	-3
Color max	3 max	D 1500	2.3	L 5.0	Red dye	L 6.0
Corrosion @ 100 °C	No. 1 max	D 130	1a	2c	2c	1a
Demulsification @ 25 °C	10 minutes max	D 1401	7	>30	>30	30
Density @ 15 °C	876 kg/m <sup>3</sup> max	D 4052	0.8424	0.8574	0.861	0.866
Distillation Initial Boiling Point		D 86	186.0	201.0	200.5	200.3
10% Point	Record		217.0	234.0	236.5	222.0
50% Point	Record		270.5	287.0	287.5	288.2
90% Point	357 °C max		326.5	339.5	337.5	339.0
End Point	385 °C max		355.5	362.5	360.0	360.5
Residue + Loss	3.0 % volume max		1.5	1.6	1.6	2.0
Flash Point	60 °C min	D 93	69.0	63	84	80
Heating Value ***	No spec. limit	D 4809Btu/lb	18,374	18,275	18,192	19,280
Hydrogen Content	12.5 wt% min	D 3701	13.61	12.989 / 12.897	12.7 (D7171)	12.74
Lubricity – BOCLE*** (wear scar dia. [mm])	No spec. limit	D5001	-Not Run-	- Not Run -	0.615	- Not Run -
Lubricity SLBOCLE*** (scuffing load [g])	No spec. limit	D 6078	-Not Run-	- Not Run -	5700	- Not Run -
Naphthalenes***	No spec. limit	D 1840% wt.	6.9	12.48	13.9	>5
Particulates	10 mg/L max	D 6217	0.90	4.4	1.3	14.0
Pour Point	-6 °C max	D 5985	-18	-12 32	-3.8	-3.8
Storage Stability	3.0 mg/100 mL max	D 5304	2.50	2.75	2.75	-11
Sulfur Content	1.0 % wt. max	D 4294% wt.	0.572	0.524 / 0.524	0.5	0.556
Thermal Stability***	180 minutes	D 6468	45.70	- Not Run -	35.4	- Not Run -
	90 minutes	% reflectance	19.70		53.1	
Trace Metals - Calcium	1.0 ppm max	In-house method	0.036	1.26	0.8	7.2
Trace Metals - Lead	0.5 ppm max	In-house method	<0.037	<0.057	<0.1	<0.4
Trace Metals - Sodium + Potassium	1.0 ppm max	In-house method	0.140	0.621	0.2	2.5-2.7
Trace Metals - Vanadium	0.5 ppm max	In-house method	0.022	0.021	0.1	<0.1
Viscosity @ 40 °C	1.7 – 4.3 cSt	D 445	2.721	3.38	3.42	3.49

\*NOTE: Tests conducted by NAVAIR (AIR 4.4.5)

\*\*NOTE: Tests conducted by SGS Herguth Laboratories (Vallejo, CA)

\*\*\*NOTE: Report only – not a specification requirement