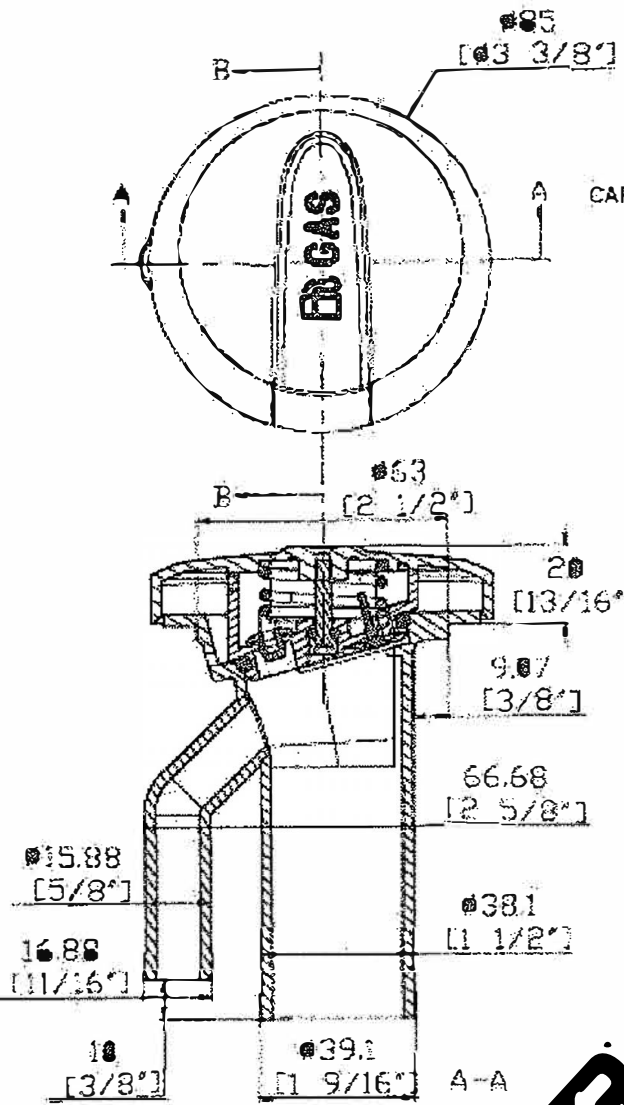

Figure 2



CAP TOP ELEVATION

DECK FILL BODY:
AVAILABLE IN STRAIGHT (AS SHOWN) AND ANGLED VERSIONS

CAP LETTERING

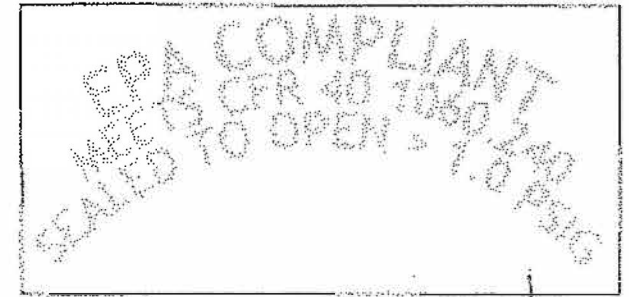
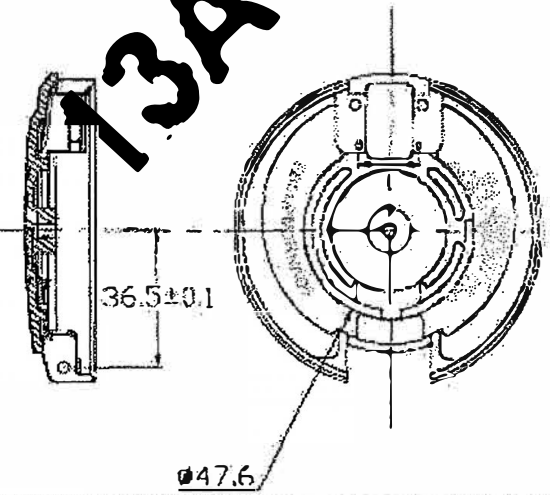

LASER

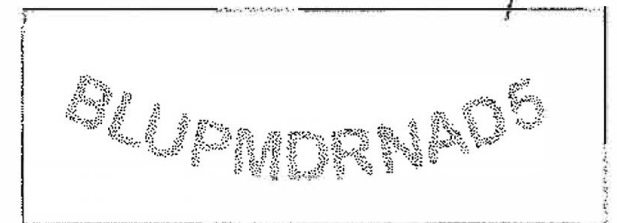

SUPERSEDED BY RM-18 13A

BluSkies

International LLC
Evaporative Emissions
Diurnal Control Systems
BLUPMDRNAD5

W/E:

FLIP TYPE
REMOTE FILL

SIZE DATE REV

B 10/19/2016

SCALE: (1) DRAWN BY: (5) SHEET 1 OF 1