

State of California
AIR RESOURCES BOARD

EXECUTIVE ORDER RM-18-012

Spark-Ignition Marine Watercraft Evaporative Emissions System Components

SeaStar Solutions
Pressure Relief Valve

WHEREAS, pursuant to California Health and Safety Code, §§ 39600, 39601, and 43013, the California Air Resources Board (CARB) has established a certification process for evaporative emissions system components designed to control gasoline emissions from spark-ignition marine watercraft (SIMW), as described in California Code of Regulations, title 13, section 2856;

WHEREAS, pursuant to California Health and Safety Code, § 43013, CARB has established criteria and test procedures for determining the compliance of evaporative emissions system components with the design requirements in Cal. Code Regs., tit. 13, § 2855;

WHEREAS, pursuant to Cal. Code Regs., tit. 13, § 2856, CARB Executive Officer may issue an executive order (EO) if he or she determines that SIMW evaporative emissions system components conform to the applicable performance requirements set forth in Cal. Code Regs., tit. 13, § 2855; and

WHEREAS, pursuant to California Health and Safety Code, §§ 39515 and 39516, CARB Executive Officer issued EO G-17-006 delegating to the Chief of CARB Monitoring and Laboratory Division (MLD) the authority to certify SIMW evaporative system components;

NOW, THEREFORE, I, Catherine Dunwoody, Chief of MLD, find that the SeaStar Solutions pressure relief valve model, BLUPMDRNAD5 listed in Table 1, contingent upon completion of required certification testing, is hereby conditionally certified to conform with performance requirements set forth in Cal. Code Regs., tit. 13, § 2855, when tested pursuant to test procedure TP-1505a.

IT IS ORDERED AND RESOLVED that the SeaStar Solutions pressure relief valve models listed in Table 1 are conditionally certified for use in SIMW introduced into commerce in California.

Table 1

Models and Specifications for SeaStar Solutions Pressure Relief Valves	
Component Type Model Number	Certified Control %
BLUPMDRNAD5 See Figure 1 for drawing of conditionally certified component	>65%

*Per TP-1505a, meets minimum required control of 65%

IT IS FURTHER ORDERED that SeaStar Solutions shall provide a warranty to watercraft manufacturers purchasing any of the SeaStar Solutions pressure relief valve models listed in Table 1. The warranty must conform to the requirements of Cal. Code Regs., tit. 13, § 2861.

IT IS FURTHER ORDERED that the conditionally certified SeaStar Solutions pressure relief valve models listed in Table 1 shall be installed in accordance with the manufacturer's installation and use instructions for the SeaStar Solutions pressure relief valve models. A copy of this EO and pressure relief valve installation and use instructions shall be provided to original watercraft manufacturers purchasing SeaStar Solutions pressure relief valve models listed in Table 1 for installation on spark-ignition marine engines and watercraft introduced into commerce in California.

IT IS FURTHER ORDERED that the SeaStar Solutions pressure relief valve models listed in Table 1 and introduced into commerce in California shall be clearly identified by a permanent identification that includes BLUPMDRNAD5.

IT IS FURTHER ORDERED that any alteration to the SeaStar Solutions pressure relief valve models listed in Table 1 and conditionally certified hereby is prohibited. Any alteration or modification of the designs approved by this EO will require the manufacturer to apply for a new EO.

IT IS FURTHER ORDERED that the SeaStar Solutions pressure relief valve models as listed in Table 1 shall be compatible with fuels in common use in California at the time of certification, and any modifications to comply with future California fuel requirements shall be approved in writing by the Executive Officer or Executive Officer's delegate.

BE IT FURTHER RESOLVED that the components listed in Table 1 are conditionally certified based on the statements of compliance in the manufacturer's Conditional Component Certification Compliance Letter. The manufacturer is required to demonstrate compliance with all applicable California evaporative emission standards and requirements, including submission of a complete component certification application, within 90 days of the date of this Executive Order.

BE IT FURTHER RESOLVED that failure to adequately demonstrate compliance within 90 days shall be cause for the CARB to revoke this Executive Order, and it will become null and void ab initio. Components introduced into commerce under the revoked

SUPERSEDED BY RM 18-017A

Executive Order shall be deemed uncertified, and the component manufacturer may be subject to enforcement actions.

IT IS FURTHER ORDERED that the component certification of the SeaStar Solutions pressure relief valve models listed in Table 1 can be referenced in certification applications for spark-ignition marine engines and watercraft that use spark-ignition marine engines unless the Executive Officer finds that the SeaStar Solutions pressure relief valve models listed in Table 1 no longer meet the performance requirements set forth in Cal. Code Regs., tit. 13, § 2855, when tested pursuant to Cal. Code Regs., tit. 13, § 2864.

Executed at Sacramento, California, this 31st day of May 2018.

Catherine Dunwoody, Chief
Monitoring and Laboratory Division

SUPERSEDED BY RM-18-012A

SUPER

Figure 1

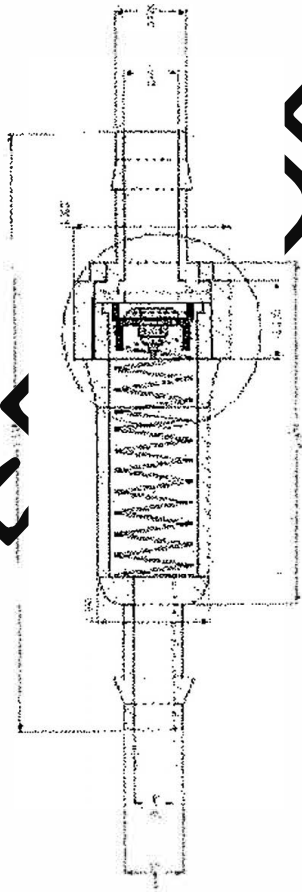

BLUPMDRNAD5

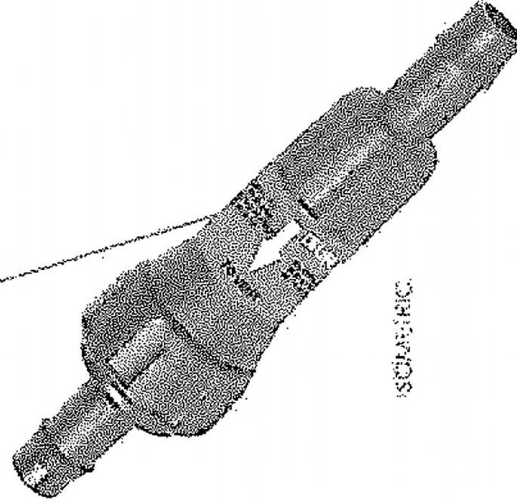
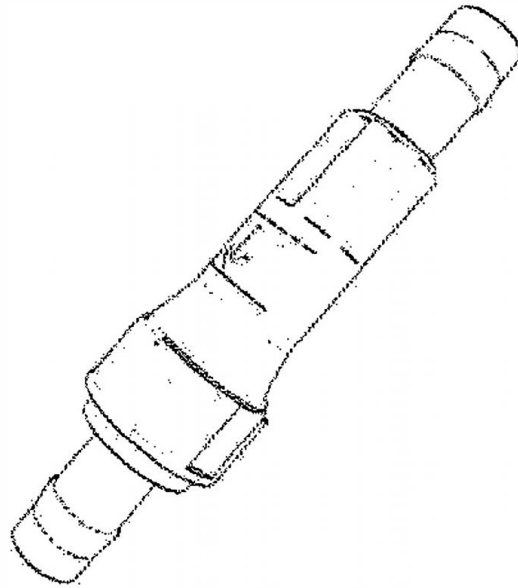

ISOMERIC

DESIGNED BY

Bluskie
International LLC

Evaporative Emissions
Diurnal Control System
BLUPMDRNAD5

Diurnal Control Valve

DATE: 10/19/2016

SCALE: 1:1 DRAWN BY: CS

SECTION

THIS AND ANY ATTACHED DRAWINGS AND THE DATA THEREON IS CONFIDENTIAL AND NOT TO BE REPRODUCED OR COPIED IN ANY MANNER WITHOUT THE WRITTEN PERMISSION OF BLUSKIE INTERNATIONAL LLC. ANY REPRODUCTION OR COPIING OF THIS DOCUMENT WITHOUT THE WRITTEN PERMISSION OF BLUSKIE INTERNATIONAL LLC IS STRICTLY PROHIBITED AND WILL BE PROSECUTED TO THE FULL EXTENT OF THE LAW.