

Contract Number: **09-621**

Evaluating the Structure and Crashworthiness of a 2020 Model-Year, Mass-Reduced Crossover Vehicle Using FEA Modeling

Prepared By:



Prepared for the California Air Resources Board (ARB)

Principal Investigator: Lotus Engineering Inc.

Date: August 31, 2012

Disclaimer

The statements and conclusions in this report are those of the contractor and not necessarily those of the California Air Resources Board. The mention of commercial products, their source, or their use in connection with material reported herein is not to be construed as actual or implied endorsement of such products.

Acknowledgements

Many individuals across many organizations contributed to this study. Lotus gratefully acknowledges the organizations below that contributed or collaborated with Lotus in some way throughout the project. These organizations do not necessarily endorse or validate this report.

AISI (materials - American International Steel Institute)
Alcoa Aluminum (materials - Ground Transportation Group)
Allied Composite Technologies LLC (materials - Rochester Hills, Michigan)
American Trim (joining and forming technologies - Lima, Ohio)
ARB (California Air Resources Board – El Monte, California)
Bayer Material Science (materials)
Böllhoff (joining technologies – Troy, Michigan; Bielefeld, Germany)
CAR (Center for Automotive Research – Ann Arbor, Michigan)
CARB (California Air Resources Board)
Department of Energy (DOE)
EBZ (manufacturing – Rochester Hills, Michigan; Ravensburg, Germany)
EPA (United States Environmental Protection Agency)
EWI (joining technologies – Columbus, Ohio)
Henkel (Automotive Group – adhesives, coatings and structural foams)
Henrob (joining technologies – Livonia, Michigan)
Hydro – Automotive Structures (materials forming – Holland, Michigan)
Intellicosting LLC (automotive costing – Troy, Michigan)
Kawasaki Robotics (joining and assembly technologies – Wixom, Michigan)
Meridian Automotive Systems (Tier 1 automotive magnesium part supplier)
National Highway Traffic Safety Administration (NHTSA)
Ohio State University (joining technologies)
Plasan Carbon Composites (Tier 1 automotive carbon fiber supplier – Bennington, Vermont)
United States Steel Corporation (Troy, Michigan)

This Report was submitted in fulfillment of CARB contract number 09-621. The objective was to use an existing lightweight vehicle concept and develop it to demonstrate that it meets Federal Motor Vehicle Safety Standards (FMVSS) for light duty vehicles. The work was performed by Lotus Engineering Inc. under the sponsorship of the California

Air Resources Board. The study was completed in the third quarter of 2011; the peer review process was completed in the third quarter of 2012.

Table of Contents

| | |
|---|----|
| 1. Abstract..... | 16 |
| 2. Executive Summary..... | 17 |
| 2.1. Background..... | 17 |
| 2.2. Methods..... | 17 |
| 2.3. Results..... | 19 |
| 2.4. Conclusions..... | 19 |
| 2.5. Recommendations..... | 21 |
| 3. Glossary of Terms, Abbreviations, and Symbols..... | 22 |
| 4. Report: Demonstrating the Safety and Crashworthiness of a 2020 Model-Year, Mass-Reduced Crossover Vehicle..... | 32 |
| 4.1. Introduction..... | 32 |
| 4.2. Materials and Methods..... | 34 |
| 4.2.1. Model Creation..... | 37 |
| 4.2.1.1. BIW..... | 39 |
| 4.2.1.2. Simulated Doors (beams only)..... | 39 |
| 4.2.1.3. Front Sub-frame/Suspension..... | 40 |
| 4.2.1.4. Rear Sub-frame/Suspension..... | 40 |
| 4.2.1.5. Cooling Pack/Front Under Hood..... | 41 |
| 4.2.1.6. Powertrain/Exhaust..... | 41 |
| 4.2.1.7. Fuel Tank/Battery..... | 42 |
| 4.2.2. Material Data..... | 43 |
| 4.2.2.1. Steel..... | 43 |
| 4.2.2.2. Aluminum..... | 45 |
| 4.2.2.3. Magnesium..... | 48 |
| 4.2.2.4. Composites..... | 49 |
| 4.2.2.5. Adhesives/Mastics/Composites..... | 50 |
| 4.2.3. Material Usage (location in vehicle)..... | 51 |
| 4.2.4. Joining Methodologies..... | 53 |
| 4.2.5. Model Mass/Other Information..... | 57 |
| 4.2.5. CAE Test Set-Up..... | 59 |
| 4.2.5.1. FMVSS 208: 35 mph Front Impact (0°/30° rigid wall, offset deformable barrier) .. | 59 |
| 4.2.5.2. FMVSS 208: 25 mph Offset Deformable Barrier..... | 60 |
| 4.2.5.3. FMVSS208: 25 mph 30° Flat Barrier – Left Side..... | 61 |
| 4.2.5.4. FMVSS208: 25 mph 30° Flat Barrier – Right Side..... | 62 |
| 4.2.5.5. FMVSS 210: Seatbelt Anchorages..... | 63 |
| 4.2.5.6. FMVSS 213: Child Restraint Systems..... | 64 |
| 4.2.5.7. FMVSS 214: 33.5 mph Side Impact – Crabbed Barrier..... | 67 |
| 4.2.5.8. FMVSS 214: 20 mph 75° Side Pole Impact – Front (5th percentile Female)..... | 68 |
| 4.2.5.9. FMVSS 214: 20 mph 75° Side Pole Impact – Front (50th percentile Male)..... | 69 |
| 4.2.5.10. FMVSS 216: Roof Crush..... | 70 |
| 4.2.5.11. FMVSS 301: Rear Impact (moving deformable barrier)..... | 71 |
| 4.2.5.12. IIHS Low Speed – Front..... | 72 |
| 4.2.5.13. IIHS Low Speed – Rear..... | 73 |
| 4.3. CAE Analysis..... | 75 |

| | | |
|---|---|-----|
| 4.3.1. | FMVSS 208: 35 mph Front Impact (0°/30° rigid wall, offset deformable barrier) | 76 |
| 4.3.2. | FMVSS 208: 25 mph Offset Deformable Barrier | 85 |
| 4.3.3. | FMVSS208: 25 mph 30° Flat Barrier – Left Side | 94 |
| 4.3.4. | FMVSS208: 25mph 30° Flat Barrier – Right Side | 100 |
| 4.3.5. | FMVSS 210: Seatbelt Anchorages | 106 |
| 4.3.5.1. | Front | 106 |
| 4.3.5.2. | Rear | 108 |
| 4.3.6. | FMVSS 213: Child Restraint Systems..... | 109 |
| 4.3.7. | FMVSS 214: 33.5 mph Side Impact – Crabbed Barrier | 110 |
| 4.3.8. | FMVSS 214: 20 mph 75° Side Pole Impact – Front (5th percentile Female) | 115 |
| 4.3.9. | FMVSS 214: 20 mph 75° Side Pole Impact – Front (50th percentile Male)..... | 120 |
| 4.3.10. | FMVSS 216: Roof Crush..... | 125 |
| 4.3.11. | FMVSS 301: Rear Impact (moving deformable barrier) | 128 |
| 4.3.12. | IIHS Low Speed – Front | 132 |
| 4.3.13. | IIHS Low Speed – Rear | 133 |
| 4.3.14. | Body Stiffness | 134 |
| 4.4. | Discussion | 137 |
| 4.4.1. | Observations - FMVSS 208 Front Impact | 137 |
| 4.4.1.1. | FMVSS 208: 35 mph Front Impact (0°/30° rigid wall, offset deformable barrier) | 138 |
| 4.4.1.2. | FMVSS 208: 25 mph Offset Deformable Barrier | 138 |
| 4.4.1.3. | FMVSS 208: 25 mph 30° Flat Barrier – Left Side | 138 |
| <p>The crash energy is once again mostly absorbed in the front bumper, front end module, left bumper bracket, and left main rail. The left shotgun inner and left front shock tower also absorb some of the crash energy as well as the engine and sub-frame. More of the energy is transmitted and absorbed by the magnesium dash panel in this test case as well, as indicated by the higher intrusion level.....</p> | | |
| 4.4.1.4. | FMVSS 208: 25 mph 30° Flat Barrier – Right Side | 139 |
| 4.4.2. | Observations – FMVSS 210 Seatbelt Anchorages | 139 |
| 4.4.2.1. | Front Anchorages..... | 139 |
| 4.4.2.2. | Rear Anchorages | 140 |
| 4.4.3. | Observations – FMVSS 213 Child Restraint Anchorage | 140 |
| 4.4.4. | Observation – FMVSS 214 Side Impact..... | 140 |
| 4.4.4.1. | FMVSS 214: 33.5 mph Crabbed Barrier | 141 |
| 4.4.4.2. | FMVSS 214: 20 mph 75° Side Pole Impact | 141 |
| 4.4.5. | Observation – FMVSS 216 Roof Crush | 141 |
| 4.4.6. | Observations – FMVSS 301 Rear Impact..... | 142 |
| 4.4.7. | Observations - IIHS Low Speed – Front..... | 142 |
| 4.4.8. | Observations - IIHS Low Speed – Rear..... | 143 |
| 4.4.9. | Vehicle-to-Vehicle Crash Results..... | 144 |
| 4.4.10. | Summary of Safety Testing Results..... | 147 |
| 4.5. | Closures..... | 149 |
| 4.5.1. | Objectives | 149 |
| 4.5.2. | Model Updates | 149 |
| 4.5.3. | Model Mass/Other Information | 152 |
| 4.5.4. | Analysis Results..... | 152 |
| 4.5.4.1. | 33.5-mph Side Impact – Crabbed Barrier | 152 |

| | | |
|------------|--|-----|
| 4.5.4.1.1. | Observations - Side Impact MDB..... | 160 |
| 4.5.4.2. | 20mph 75° Side Pole Impact – Front (5th Percentile Female) | 161 |
| 4.5.4.3. | 20-mph 75° Side Pole Impact – Front (50th percentile Male)..... | 166 |
| 4.5.4.3.1. | Observations - Side Impact Pole..... | 171 |
| 4.5.4.4. | Roof Crush..... | 173 |
| 4.5.4.4.1. | Observations - Roof Crush..... | 177 |
| 4.5.4.5. | Rear Impact..... | 178 |
| 4.5.4.5.1. | Observations - Rear Impact | 183 |
| 4.5.4.6. | IIHS Low Speed – Rear | 185 |
| 4.5.4.6.1. | Observations - IIHS Low Speed – Rear..... | 188 |
| 4.5.5. | Bill of Materials..... | 190 |
| 4.5.5.1 | Closures Bill of Materials | 198 |
| 4.5.6. | Vehicle Manufacturing | 201 |
| 4.5.6.1 | Assembly..... | 201 |
| 4.5.6.2 | Labor | 203 |
| 4.5.6.3 | Investment and Manufacturing Costs | 204 |
| 4.5.7. | Cost Discussion..... | 218 |
| 4.5.7.1 | Phase 1 Cost Study..... | 218 |
| 4.5.7.2 | Phase 2 Cost Study..... | 220 |
| 4.5.7.3 | Closures Piece Costs..... | 226 |
| 4.5.7.4 | Phase 2 HD BIW Technology..... | 228 |
| 4.5.8. | Application of Results to Other Vehicle Classes | 231 |
| 4.5.8.1. | Body-in-White | 231 |
| 4.5.8.1.1. | Modularization..... | 231 |
| 4.5.8.1.2. | Materials | 232 |
| 4.5.8.1.3. | Aluminum Extrusions and Stampings | 232 |
| 4.5.8.1.4. | Magnesium Castings..... | 233 |
| 4.5.8.1.5. | High Strength Steel..... | 233 |
| 4.5.8.1.6. | Composites..... | 233 |
| 4.5.8.1.7. | Scalability Summary..... | 234 |
| 4.5.8.2. | Closures..... | 239 |
| 4.5.8.2.1. | Injection Molding..... | 239 |
| 4.5.8.2.2. | Mild Steel Castings..... | 239 |
| 4.5.8.2.3. | Scalability Summary..... | 239 |
| 4.5.8.3. | Front and Rear Bumpers | 240 |
| 4.5.8.4. | Glazing (Windshield, Backlight, Doors, Sunroof, Fixed Panels)..... | 240 |
| 4.5.8.5. | Interior..... | 240 |
| 4.5.8.5.1. | Seats | 240 |
| 4.5.8.5.2. | Electronic Transmission and Parking Brake Controls | 241 |
| 4.5.8.5.3. | Instrument Panel | 241 |
| 4.5.8.5.4. | Center Console..... | 242 |
| 4.5.8.5.5. | Noise Insulation | 242 |
| 4.5.8.5.6. | Interior Trim..... | 242 |
| 4.5.8.5.7. | HVA/C Ducting | 243 |
| 4.5.8.6. | Chassis and Suspension | 243 |
| 4.5.8.6.1. | Suspension and Steering | 243 |

| | | |
|------------|---|-----|
| 4.5.8.6.2. | Braking System..... | 243 |
| 4.5.8.6.3. | Tires and Wheels..... | 244 |
| 4.5.8.7. | Electrical..... | 244 |
| 4.5.8.8. | Powertrain..... | 244 |
| 4.5.8.9. | Competitive Set Study..... | 246 |
| 4.5.8.10. | Summary and Projected Weight Savings..... | 247 |
| 4.6.1 | Conclusions..... | 249 |
| 4.6.2 | Recommendations..... | 250 |
| 5. | References..... | 250 |
| 6. | List of Inventions Reported and Copyrighted Materials Produced..... | 252 |
| 7. | Appendices..... | 1 |
| 7.1. | Appendix A: Manufacturing Report..... | 1 |
| 1.0 | General Assumptions..... | 2 |
| 2.0 | Process & Layout..... | 2 |
| 2.5.1 | Sub-Assemblies..... | 59 |
| 2.5.2 | Underbody Line..... | 60 |
| 2.5.3 | Cross Transport..... | 60 |
| 2.5.4 | Framing Line..... | 60 |
| 2.5.5 | After Framing Line..... | 60 |
| 2.6 | Buffer Concept..... | 60 |
| 2.7 | Station Layouts..... | 60 |
| 6.0 | Quality Concept..... | 92 |
| 6.1 | Philosophy..... | 92 |
| 6.2 | Quality Assurance Methods..... | 93 |
| 6.2.1 | In-Line Quality Check..... | 93 |
| 6.2.2 | Off-Line Quality Check..... | 94 |
| 7.0 | Maintenance Concept..... | 95 |
| 8.0 | Environmental Assumptions..... | 97 |
| 8.1 | Solar Panels..... | 97 |
| 8.2 | Wind Turbines..... | 97 |
| 8.3 | Biomass Power..... | 98 |
| 8.4 | Water Recycle..... | 98 |
| 8.5 | Lighting..... | 98 |
| 8.6 | Recycling, Reusables, and Returnables..... | 98 |
| 8.7 | Living Roof..... | 99 |
| 8.8 | Solvent Recovery..... | 99 |
| 8.9 | Plant Surroundings..... | 99 |
| 9.0 | Investment/Costs..... | 100 |
| 9.1 | Capital Costs..... | 100 |
| 9.2 | Labor Costs..... | 107 |
| 9.3 | Utilities..... | 108 |
| 9.4 | Investment Summary..... | 109 |
| 9.5 | Sensitivity Analysis..... | 111 |
| 9.6 | Tooling Costs..... | 114 |
| 7.1.1 | Closures Manufacturing Report..... | 125 |
| 7.2 | Appendix B: Competitive Set Study..... | 1 |

| | | |
|--------|--|---|
| 7.3 | Appendix C: 2009 Toyota Venza and Phase 2 HD Piece Costs | 1 |
| 7.1.1. | Appendix D: Intellicosting Methodology | 1 |

List of Tables and Figures

| | |
|--|----|
| Table 4.2.a: Overview of the report and tasks | 34 |
| Figure 4.2.1.a: Phase 1 High Development Model Exterior Styling – Front..... | 37 |
| Figure 4.2.1.b: Baseline Toyota Venza Exterior Styling – Front | 38 |
| Figure 4.2.1.c: Phase 1 High Development Model Exterior Styling – Rear..... | 38 |
| Figure 4.2.1.d: Baseline Toyota Venza Exterior Styling – Rear | 38 |
| Figure 4.2.1.1.a: Body-in-white – Front | 39 |
| Figure 4.2.1.2.a: Simulated door beams | 39 |
| Figure 4.2.1.3.a: Front sub-frame and suspension | 40 |
| Figure 4.2.1.4.a: Rear sub-frame and suspension | 40 |
| Figure 4.2.1.5.a: Cooling and under hood | 41 |
| Figure 4.2.1.6.a: Powertrain and exhaust..... | 41 |
| Figure 4.2.1.7.a: Fuel tank/battery | 42 |
| Figure 4.2.2.1.a: Steel stress-strain curve at 300 MPa..... | 43 |
| Figure 4.2.2.1.b: Steel stress-strain curve at 400 MPa..... | 44 |
| 4.2.2.1.c: Hot-stamped, boron steel stress-strain curve | 44 |
| Figure 4.2.2.2.a: 6013 aluminum stress-strain curve | 45 |
| Figure 4.2.2.2.b: 6022 aluminum stress-strain curve..... | 45 |
| Figure 4.2.2.2.c: 6061 aluminum stress-strain curve | 46 |
| Figure 4.2.2.2.d: 6063 aluminum stress-strain curve..... | 46 |
| Figure 4.2.2.2.e: 6013 aluminum stress-strain curve | 47 |
| Figure 4.2.2.3.a: AM60 magnesium stress-strain curve | 48 |
| Figure 4.2.2.4.a: 45-2a nylon stress-strain curve | 49 |
| Figure 4.2.2.4.b: 60-percent glass-fiber PET stress-strain curve..... | 49 |
| Figure 4.2.2.5.a: 1811 Terocore stress-strain curve..... | 50 |
| Figure 4.2.2.5.b: Terokal stress-strain curve..... | 50 |
| Figure 4.2.3.a: Body-in-white material usage front three-quarter view | 51 |
| Figure 4.2.3.b: Body-in-white material usage rear three-quarter view..... | 52 |
| Figure 4.2.3.c: Body-in-white material usage underbody view..... | 52 |
| Figure 4.2.3.d: Body-in-white Material Usage Exploded View | 53 |
| Figure 4.2.4.a: Typical Joint Sections..... | 55 |
| Figure 4.2.4.b: Henkel & Kawasaki lap-shear tests..... | 56 |
| Table 4.2.5.a: Phase 1 High Development System Masses | 57 |
| Figure 4.2.5.1.a: Rigid, deformable wall crash-test model setup | 59 |
| Figure 4.2.5.2.a: 40-percent barrier overlap crash-test model setup..... | 60 |
| Figure 4.2.5.3.a: 30°, left-side barrier crash-test model setup | 61 |
| Figure 4.2.5.4.a: 30°, right-side barrier crash-test model setup..... | 62 |
| Figure 4.2.5.5.a: Front seatbelt anchorage test model setup..... | 63 |
| Figure 4.2.5.5.b: Rear seatbelt anchorage test model setup..... | 64 |
| Figure 4.2.5.6.a: Acceleration pulse applied to child-restraint model | 65 |
| Figure 4.2.5.6.b: Child-restraint test model setup..... | 66 |
| Figure 4.2.5.7.a: Crabbed barrier test model setup | 67 |
| Figure 4.2.5.8.a: Side-pole impact test model setup | 68 |
| Figure 4.2.5.9.a: Side-pole impact test model setup | 69 |
| Figure 4.2.5.10.a: Roof crush test model setup..... | 70 |

| | |
|--|-----|
| Figure 4.2.5.11.a: Deformable, moving barrier rear impact test model setup | 71 |
| Figure 4.2.5.12.a: IIHS, low-speed, front test model setup ('full impact') | 72 |
| Figure 4.2.5.12.b: IIHS, low-speed front test model setup ('offset impact') | 73 |
| Figure 4.2.5.13.a: IIHS, low-speed rear test model setup ('full impact') | 73 |
| Figure 4.2.5.13.b: IIHS, low-speed rear test model setup ('offset impact') | 74 |
| Figure 4.3.1.a: Vehicle deformation (t=0.1 s) after frontal impact..... | 76 |
| Figure 4.3.1.b: Vehicle acceleration pulse during frontal impact..... | 77 |
| Figure 4.3.1.c: Average vehicle acceleration pulse during frontal impact | 78 |
| Figure 4.3.1.d: Vehicle velocity during frontal impact - time to 0 velocity (TTZ) = 59.5 ms | 79 |
| Figure 4.3.1.e: Vehicle acceleration during frontal impact | 80 |
| Figure 4.3.1.f: Vehicle displacement from frontal impact - max dynamic crush = 555 mm..... | 81 |
| Figure 4.3.1.g: CAE dash intrusion analysis after frontal impact..... | 82 |
| Figure 4.3.1.h: Fuel tank plastic strain after impact | 82 |
| Figure 4.3.1.i: Main energy absorbing frontal body structure | 83 |
| Figure 4.3.1.j: Energy balance for frontal impact..... | 84 |
| Figure 4.3.2.a: Vehicle deformation (t=0.15 s) after 40-percent overlap frontal impact..... | 85 |
| Figure 4.3.2.b: Vehicle deformation (t=0.15 s, barrier not shown) after 40-percent overlap frontal impact..... | 86 |
| Figure 4.3.2.c: Vehicle acceleration pulse during 40-percent overlap frontal impact..... | 86 |
| Figure 4.3.2.d: Average vehicle pulse during 40-percent overlap frontal impact | 88 |
| Figure 4.3.2.e: Vehicle velocity after 40-percent overlap frontal impact - time to zero (TTZ) = 0.117 s | 88 |
| Figure 4.3.2.f: Vehicle displacement after 40-percent overlap frontal impact | 89 |
| Figure 4.3.2.g: CAE dash intrusion analysis after 40-percent overlap frontal impact..... | 89 |
| Figure 4.3.2.h: Toyota Venza NCAP dash deformation..... | 90 |
| Figure 4.3.2.i: Main energy absorbing body structure – 40-percent overlap frontal impact | 91 |
| Figure 4.3.2.j: Energy balance for 40-percent overlap frontal impact..... | 91 |
| Figure 4.3.2.k: Comparison of production vehicle and Phase 2 HD crash accelerations | 92 |
| Figure 4.3.2.l: Comparison of production vehicle envelope and Phase 2 HD crash accelerations | 93 |
| Figure 4.3.3.a: Vehicle deformation (t=0.12 s) after 30°, left-side frontal barrier impact | 94 |
| Figure 4.3.3.b: Vehicle acceleration pulse during 30°, left-side frontal barrier impact | 95 |
| Figure 4.3.3.c: Average vehicle acceleration pulse during 30°, left-side frontal barrier impact .. | 96 |
| Figure 4.3.3.d: Vehicle velocity during 30°, left-side frontal impact - time to 0 velocity (TTZ) = 76 ms..... | 96 |
| Figure 4.3.3.e: Vehicle displacement during 30°, left-side frontal impact – max dynamic crush = 500 mm | 97 |
| Figure 4.3.3.f: CAE dash intrusion analysis after 30°, left-side frontal impact..... | 97 |
| Figure 4.3.3.g: Fuel tank plastic strain after 30°, left-side frontal impact | 98 |
| Figure 4.3.3.h: Main energy absorbing body structure for fuel tank plastic strain after 30°, left-side frontal impact..... | 98 |
| Figure 4.3.3.i: Energy balance for 30°, left-side frontal impact | 99 |
| Figure 4.3.4.a: Vehicle deformation (t=0.12 s) after 30°, right-side frontal impact..... | 100 |
| Figure 4.3.4.b: Vehicle acceleration pulse during 30°, right-side frontal impact..... | 101 |
| Figure 4.3.4.c: Vehicle average acceleration pulse during 30°, right-side frontal impact..... | 101 |
| Figure 4.3.4.d: Vehicle velocity during 30°, right-side frontal impact..... | 102 |

| | |
|--|-----|
| - time to zero velocity (TTZ) = 92 ms | 102 |
| Figure 4.3.4.e: Vehicle displacement during 30°, right-side frontal impact - maximum dynamic crush 524 mm..... | 102 |
| Figure 4.3.4.f: CAE dash intrusion analysis after 30°, right-side frontal impact | 103 |
| Figure 4.3.4.g: Fuel tank plastic strains after 30°, right-side frontal impact | 103 |
| Figure 4.3.4.h: Main energy absorbing body structure for 30°, right-side frontal impact..... | 104 |
| Figure 4.3.4.i: Energy balance for 30°, right-side frontal impact..... | 105 |
| Figure 4.3.5.1.a: Seatbelt anchorage plastic strains (@ 0.2 s) | 106 |
| Figure 4.3.5.1.b: Upper seatbelt anchorage plastic strain (@ 0.2 s) | 107 |
| Figure 4.3.5.1.c: Lower seatbelt anchorage plastic strain (@ 0.2 s)..... | 107 |
| Figure 4.3.5.2.a: Rear seatbelt anchorage plastic strain (@ 0.2 s)..... | 108 |
| Figure 4.3.5.2.b: Displacement at lower seatbelt anchorages (@0.2 s)..... | 108 |
| Figure 4.3.6.a: Child-restraint, lower anchorage plastic strain | 109 |
| Figure 4.3.6.b: Child-restraint seat pan displacements | 109 |
| Figure 4.3.7.a: Vehicle deformation (0.1 s) after crabbed barrier impact | 110 |
| Figure 4.3.7.b: Vehicle deformation (barrier not shown) after crabbed barrier impact..... | 111 |
| Figure 4.3.7.c: Global vehicle and barrier velocities for crabbed barrier impact | 111 |
| Figure 4.3.7.d: Relative intrusion velocities (B-pillar) during crabbed barrier impact | 112 |
| Figure 4.3.7.e: Relative intrusion displacements (B-pillar) during crabbed barrier impact | 112 |
| Figure 4.3.7.f: B-pillar intrusion profile after crabbed barrier impact, x=2842..... | 113 |
| Figure 4.3.7.g: Intrusion levels after crabbed barrier impact on struck side | 113 |
| Figure 4.3.7.h: Main energy absorbing body structure parts for crabbed barrier impact | 114 |
| Figure 4.3.7.i: Energy balance for crabbed barrier impact | 114 |
| Figure 4.3.8.a: Vehicle deformation (0.1 s) after 75°, side, pole impact – 5 th percentile female | 115 |
| Figure 4.3.8.b: Vehicle deformation after 75°, side, pole impact (pole blanked) – 5 th percentile female..... | 116 |
| Figure 4.3.8.c: Relative intrusion velocities during 75°, side, pole impact (B-pillar) – 5 th percentile female..... | 116 |
| Figure 4.3.8.d: Relative intrusion displacements during 75°, side, pole impact (B-pillar) – 5 th percentile female..... | 117 |
| Figure 4.3.8.e: Section through B-pillar after 75°, side, pole impact, x= 2842 – 5 th percentile female..... | 117 |
| Figure 4.3.8.f: Intrusion levels after 75°, side, pole impact on struck side – 5 th percentile female | 118 |
| Figure 4.3.8.g: Main energy absorbing body structure for 75°, side, pole impact – 5 th percentile female..... | 118 |
| Figure 4.3.8.h: Energy balance for 75°, side, pole impact – 5 th percentile female | 119 |
| Figure 4.3.9.a: Vehicle deformation (0.1 s) after 75°, side, pole impact – 50 th percentile male | 120 |
| Figure 4.3.9.b: Vehicle deformation after 75°, side, pole impact (pole blanked) – 50 th percentile male..... | 121 |
| Figure 4.3.9.c: Relative intrusion velocities during 75°, side, pole impact (B-pillar) – 50 th percentile male | 121 |
| Figure 4.3.9.d: Relative intrusion displacements during 75°, side, pole impact (B-pillar) – 50 th percentile male | 122 |
| Figure 4.3.9.e: Intrusion levels after 75°, side, pole impact on struck side – 50 th percentile male | 122 |

| | |
|---|-----|
| Figure 4.3.9.f: Section through B-pillar after 75°, side, pole impact, x= 2842 – 50 th percentile male..... | 123 |
| Figure 4.3.9.g: Main energy absorbing body structure for 75°, side, pole impact – 50 th percentile male..... | 123 |
| This energy balance validated the analysis, showing no energy was created or destroyed during the simulation..... | 124 |
| Figure 4.3.10.a: Deformation at 0/40/80/150 mm of roof crush platen displacement..... | 125 |
| Figure 4.3.10.b: Deformation in relation to occupant head clearance zones (95 th /99 th) at 0/40/80/150 mm of roof crush platen displacement | 126 |
| Figure 4.3.10.c: Roof displacement vs. applied force – 3 times curb weight..... | 126 |
| Figure 4.3.10.d: Roof displacement vs. applied force – 3 times Venza weight..... | 127 |
| Figure 4.3.10.e: Roof plastic strains at 0/40/80/150 mm of roof crush platen displacement | 127 |
| Figure 4.3.11.a: Vehicle deformation (t=0.12 s) after rear deformable barrier impact | 128 |
| Figure 4.3.11.b: Vehicle deformation (barrier blanked) after rear deformable barrier impact... .. | 128 |
| Figure 4.3.11.c: Vehicle deformation (at 0/40/80/120 ms) after rear deformable barrier impact | 129 |
| Figure 4.3.11.d: Vehicle acceleration pulse during rear deformable barrier impact | 129 |
| Figure 4.3.11.e: Vehicle and barrier velocities during rear deformable barrier impact..... | 130 |
| Figure 4.3.11.f: Fuel tank plastic strains after rear deformable barrier impact | 130 |
| Figure 4.3.11.g: Main energy absorbing body structure for rear deformable barrier impact | 131 |
| Figure 4.3.11.h: Energy balance for rear deformable barrier impact..... | 131 |
| Figure 4.3.12.a: Front plastic strain after low-speed frontal impact (‘full impact’) | 132 |
| Figure 4.3.12.b: Front plastic strain after low-speed frontal impact (‘offset impact’) | 132 |
| Figure 4.3.13.a: Rear plastic strains after low-speed rear impact (‘full impact’) | 133 |
| Figure 4.3.13.b: Rear plastic strains after low-speed rear impact (‘offset impact’) | 133 |
| Table 4.3.14.a: Torsional stiffness..... | 134 |
| Figure 4.3.14.a: CAE body stiffness analysis..... | 134 |
| Table 4.3.14.b: Torsional stiffness comparison | 135 |
| Figure 4.4.9.a: Phase 2 HD vehicle to Ford Taurus crash simulation setup – three-quarter view | 144 |
| Figure 4.4.9.b: Phase 2 HD vehicle to Ford Taurus crash simulation setup – side view..... | 145 |
| Figure 4.4.9.c: Phase 2 HD vehicle to Ford Taurus crash simulation result – three-quarter view | 145 |
| Figure 4.4.9.d: Phase 2 HD vehicle to Ford Taurus crash simulation result – side view | 146 |
| Figure 4.4.9.e: Phase 2 HD vehicle to Ford Taurus crash simulation result – three-quarter view, opaque Taurus | 146 |
| Table 4.4.10.a: Summary of Vehicle Test Validation | 147 |
| Figure 4.5.2.a: Body-in-White – V27 | 150 |
| Figure 4.5.2.b: Front closure view | 151 |
| Figure 4.5.2.c: Rear closure view | 152 |
| Figure 4.5.4.1.a: Model analysis setup | 153 |
| Figure 4.5.4.1.b: Vehicle Deformation (0.1s)..... | 154 |
| Figure 4.5.4.1.c: Vehicle Deformation (barrier not shown) | 154 |
| Figure 4.5.4.1.d: Global Vehicle and Barrier Velocities | 155 |
| Figure 4.5.4.1.e: Relative Intrusion Velocities (B-pillar)..... | 155 |
| Figure 4.5.4.1.f: Relative Intrusion Displacements (B-pillar) | 156 |

| | |
|---|-----|
| Figure 4.5.4.1.g: Relative Intrusion Displacements (Front/Rear Door) | 156 |
| Figure 4.5.4.1.h: B-Pillar Intrusion profile x=2842 | 157 |
| Figure 4.5.4.1.i: Intrusion levels on Struck-side | 158 |
| Figure 4.5.4.1.j: Plastic Strain in Struck-side Doors | 158 |
| Figure 4.5.4.1.k: Energy Balance | 159 |
| Figure 4.5.4.2.a: 20-mph, 75-degree side-pole impact -- front (5th percentile female) model setup | 161 |
| Figure 4.5.4.2.b: Vehicle Deformation (0.1s) | 162 |
| Figure 4.5.4.2.c: Vehicle deformation from 20-mph, 75-degree side-pole impact -- front (5th percentile female, pole blanked) | 162 |
| Figure 4.5.4.2.d: Intrusion Velocities (B-Pillar & Front Door) | 163 |
| Figure 4.5.4.2.e: Intrusion Displacements (B-Pillar & Front Door) | 163 |
| Figure 4.5.4.2.f: Section through B-Pillar, x= 2842 | 164 |
| Figure 4.5.4.2.g: Intrusion levels on struck side | 164 |
| Figure 4.5.4.2.h: Energy Balance | 165 |
| Figure 4.5.4.3.a: 20-mph, 75-degree side-pole impact -- front (50th percentile male) model setup | 166 |
| Figure 4.5.4.3.b: Vehicle Deformation (0.1s) after impact | 166 |
| Figure 4.5.4.3.c: Vehicle Deformation (Pole Blanked) | 167 |
| Figure 4.5.4.3.d: Intrusion Velocities (B-Pillar & Front Door) after 20-mph, 75-degree side-pole impact -- front (50 th percentile male) | 167 |
| Figure 4.5.4.3.e: Intrusion Displacements (B-Pillar & Front Door) after 20-mph, 75-degree side-pole impact -- front (50 th percentile male) | 168 |
| Figure 4.5.4.3.f: Intrusion levels on struckside after 20-mph, 75-degree side-pole impact -- front (50 th percentile male) | 168 |
| Figure 4.5.4.3.g: Section through B-Pillar, x= 2842 after 20-mph, 75-degree side-pole impact -- front (50 th percentile male) | 169 |
| Figure 4.5.4.3.h: Plastic Strain in Front Door after 20-mph, 75-degree side-pole impact -- front (50 th percentile male) | 169 |
| Figure 4.5.4.3.i: Energy Balance for 20-mph, 75-degree side-pole impact -- front (50 th percentile male) | 170 |
| Figure 4.5.4.3.1.a: 5 th percentile female vs. 50 th percentile male front door intrusion comparison | 171 |
| Figure 4.5.4.4.a: Roof crush model setup | 173 |
| Figure 4.5.4.4.b: Deformation at 0/40/80/150mm of Platen Displacement | 174 |
| Figure 4.5.4.4.c: Deformation in Relation to occupant head clearance zones (95 th /99 th) @ 0/40/80/150mm of Platen Displacement | 174 |
| Figure 4.5.4.4.d: Roof Displacement vs. Applied Force – 3 times Curb Weight | 175 |
| Figure 4.5.4.4.e: Roof Displacement vs. Applied Force – 3 times Venza Weight | 175 |
| Figure 4.5.4.4.f: Plastic Strains @ 0/40/80/150mm of Roof Platen Displacement | 176 |
| Figure 4.5.4.4.1.a: Resultant force magnitude in A & B-Pillars from roof crush test | 177 |
| Figure 4.5.4.5.a: Rear Impact Model Set up | 178 |
| Figure 4.5.4.5.b: Vehicle Deformation (t=0.12s) | 179 |
| Figure 4.5.4.5.c: Vehicle Deformation (Barrier Blanked) | 179 |
| Figure 4.5.4.5.d: Vehicle Deformation (@ 0ms/40ms/80ms/120ms) after rear impact | 180 |
| Figure 4.5.4.5.e: Vehicle Acceleration Pulse during rear impact | 180 |

| | |
|---|-----|
| Figure 4.5.4.5.f: Vehicle & Barrier Velocities during rear impact simulation | 181 |
| Figure 4.5.4.5.g: Fuel Tank Plastic Strains after rear impact | 181 |
| Figure 4.5.4.5.h: Rear impact energy balance | 182 |
| Figure 4.5.4.5.1.a: Fuel Tank Plastic Strain location after rear impact | 183 |
| Figure 4.5.4.5.1.b: Initial vehicle armature rotation during rear impact..... | 184 |
| Figure 4.5.4.6.a: Low-speed IIHS impact model setup ('full') | 185 |
| Figure 4.5.4.6.b: IIHS low-speed impact element plastic strains ('full') | 186 |
| Figure 4.5.4.6.c: IIHS low-speed impact model setup ('offset') | 186 |
| Figure 4.5.4.6.d: IIHS low-speed impact element plastic strain ('offset') | 187 |
| Figure 4.5.4.6.1.a: Maximum deflection showing barrier intrusion into tailgate | 188 |
| Figure 4.5.4.6.1.b: 'Deformation' @ maximum deflection | 189 |
| Table 4.5.5.a: Bill of Materials | 190 |
| Table 4.5.5.b: Phase 2 HD Vehicle Body Structure | 195 |
| Table 4.5.5.c: Summary of changes from Phase 1 HD to Phase 2 HD..... | 196 |
| Figure 4.5.5.a: Venza, Phase 1, and Phase 2 vehicle body structure by material..... | 196 |
| Table 4.5.5.d: Venza, Phase 1, and Phase 2 system masses | 197 |
| Figure 4.5.5.b: Venza, Phase 1, and Phase 2 full vehicle material composition | 198 |
| Table 4.5.5.1.a: Closures BOM | 198 |
| Table 4.5.6.1.a: Assembly stations, functions, and parts | 201 |
| Table 4.5.6.1.b: Cycle time calculations | 203 |
| Table 4.5.6.2.a: Phase 2 HD BIW estimated labor costs | 203 |
| Table 4.5.6.2.b: Phase 2 HD BIW estimated labor cost increases with 3% annual raises..... | 204 |
| Table 4.5.6.3.a: Phase 2 HD BIW tooling cost..... | 204 |
| Table 4.5.6.3.b: Toyota Venza and Phase 2 HD BIW piece costs..... | 214 |
| Table 4.5.6.3.c: Phase 2 HD BIW manufacturing costs | 215 |
| Table 4.5.6.3.d: BIW cost based on recommended amortization schedule with tooling..... | 215 |
| Table 4.5.6.3.e: Straight 3- and 5-year amortization schedule | 216 |
| Table 4.5.6.3.f: Assembly cost breakdown by body section | 216 |
| Table 4.5.6.3.g: Manufacturing sensitivity analysis | 217 |
| Figure 4.5.7.1.a: Estimated Vehicle System Costs | 218 |
| Table 4.5.7.1.a: Phase 1 HD Estimated Vehicle Cost Increase | 219 |
| Table 4.5.7.1.b: Estimated direct manufacturing costs of the Toyota Venza baseline and Phase 1 High Development vehicle design | 220 |
| Table 4.5.7.2.a: Assembled BIW analysis | 221 |
| Table 4.5.7.2.b: Assembly, paint, tooling, and NVH cost analysis | 221 |
| Table 4.5.7.2.c: Piece, assembly, tooling, paint, and NVH sub-category costs..... | 222 |
| Table 4.5.7.2.d: Amortization schedule comparison | 222 |
| Table 4.5.7.2.e: Phase 2 Estimated Vehicle Cost Increase | 223 |
| Table 4.5.7.2.f: Estimated direct manufacturing costs of the Toyota Venza baseline and Phase 2 HD vehicle designs | 223 |
| Table 4.5.7.2.g: Phase 2 full vehicle sensitivity study..... | 224 |
| Table 4.5.7.2.h: Fully Amortized Body in White Cost..... | 225 |
| Table 4.5.7.2.i: Phase 2 full vehicle sensitivity study..... | 225 |
| Table 4.5.7.2.j: Phase 2 full vehicle sensitivity study – Non-BIW Cost parity | 226 |
| Table 4.5.7.3: Closure piece and tooling costs | 226 |
| Figure 4.5.8.1.7.a: Toyota Yaris body-in-white structure..... | 236 |

| | |
|---|-----|
| Figure 4.5.8.1.7.b: Toyota Corolla body-in-white structure | 236 |
| Figure 4.5.8.1.7.c: Audi A4 body-in-white structure..... | 237 |
| Figure 4.5.8.1.7.d: Audi A7 body-in-white-structure | 237 |
| Table 4.5.8.1.7.a: Body-in-white specific densities..... | 238 |
| Table 4.5.8.1.7.b: Shape factors..... | 238 |
| Table 4.5.8.9.a: Average vehicle class information..... | 246 |
| Table 4.5.8.9.b: Vehicle volume calculations based on shape factors..... | 246 |
| Table 4.5.8.10.a: Projected total vehicle weight savings by vehicle class..... | 248 |
| Table 4.5.8.10.b: Estimated mass and cost factors for various vehicle classes | 248 |

1. Abstract

The California Air Resources Board (ARB) contracted Lotus Engineering Inc. to create a theoretical model and analyze the structural and impact performance of a low-mass vehicle body-in-white such as the crossover vehicle described in Lotus' 2010 lightweight vehicle study, An Assessment of Mass Reduction Opportunities for a 2017-2020 Model Year Vehicle Program. The 2010 peer reviewed study developed a vehicle comparable to the 2009 Toyota Venza; this model had equivalent dimensions, utility objectives, and passenger and interior volume. The projected mass reduction for the 2020 model year (MY) was 38 percent less mass for all systems except powertrain; this configuration was used as a starting point for this study. The masses for all non-BIW systems were carried over from the Phase 1 report and are listed in Table 4.2.5.a. A CAD model of the body structure, called a Body in White (BIW), was designed and a BOM (Bill of Material) was created to track the parts. The mass reduction target was 40%. Computer aided analysis and simulation were used to evaluate the crash and structural performance of the reduced mass CAD model. The following theoretical study indicates that a low-mass body structure has the potential to meet Federal Motor Vehicle Safety Standards (FMVSS) for light duty vehicles for front, side, and rear impacts, roof crush, occupant restraints and several Insurance Institute for Highway Safety requirements.

This study also provides a discussion on the applicability of low-mass body structure engineering and manufacturing to other vehicle classes as well as a bill of material with a full cost analysis for the engineering and manufacturing of a body structure. A manufacturing facility study is included to verify feasibility for building the BIW, to estimate the cost for building the body assembly and to estimate the cost to upfit an existing plant to build the low mass BIW. The target timing is initial production in 2020 with widespread introduction by 2025. Both low volume and high volume studies are included. Lotus evaluated the functional design based on both direct costs and assembly considerations before refining the design to further reduce costs and improve assembly.

2. Executive Summary

2.1. Background

CARB contracted Lotus Engineering Inc to design a low-mass body structure and to evaluate the performance for key federal (FMVSS) and Insurance Institute for Highway Safety (IIHS) requirements for a 2020 model year vehicle, which could be widely commercialized by 2025. The target was a mass reduction greater than 30 percent for the total vehicle. An original vehicle concept, referred to as Phase 1 in this report, was developed in 2009 and released publicly in 2010 by the International Council on Clean Transportation. This follow up study, defined as Phase 2, evaluated the crash performance of a reduced-mass vehicle relative to federal and IIHS standards. The investigation took place between December 2010 and October 2011.

As a part of this study Lotus shared the FMVSS impact models with NHTSA and held regular meetings to compare results with the NHTSA analysis team. Additionally, NHTSA used in-house models to perform vehicle to vehicle impacts with the Lotus low mass model, including a Ford Taurus and a Ford Explorer.¹

NHTSA is issuing a separate report documenting the car to car impact results (<http://www.nhtsa.gov/Laws+&+Regulations/CAFE+-+Fuel+Economy/Research+Supporting+2017-2025+CAFE+Final+Rule>).

2.2. Methods

Lotus Engineering based this Phase 2 study on the over 30-percent mass reduced vehicle (curb weight – includes powertrain) developed in the Phase 1 study and performed crash simulations to evaluate the structure and crash performance relative to Federal Motor Vehicle Safety Standards (FMVSS) for light duty vehicles for front, side, and rear impacts, roof crush and certain IIHS requirements.

For the Phase 2 study, Lotus designed a new body structure based on the Phase 1 body-in-white (BIW) with identical exterior and interior dimensions to the original baseline vehicle, a 2009 Toyota Venza. The Venza was customer selected; it was representative of the crossover utility vehicle category.

The engineering methodology consisted of:

1. Total Structure Approach
 - a. Investigate all areas simultaneously using topology
 - b. Minimize total BIW mass

- i. Holistic approach targeting best solution for total body structure by transferring loads efficiently throughout the vehicle
2. Optimize load paths within structures and minimize torques to reduce stresses on components
3. Maximize structural sections
4. Design each part to be a structural element
5. High level of component integration & function
6. Eliminate parts
7. Optimize design for each material class used
 - a. Ferrous
 - b. Non-ferrous
 - c. Composites
 - d. Natural materials

As an example of 4, 5, and 6, the front shock towers were castings. These castings integrated the equivalent of five typical sheet metal stampings that need to be formed and welded together. Each stamping requires at least one tool; if a deep draw is required, there may be additional “progressive” dies required to ensure that the material doesn’t tear during the forming process. There can be three or more “prog” dies for a typical deep draw part. The integrated casting minimally eliminated four tools as well as the scrap material associated with the stamping process. The number of stamping tools could be significantly higher if progressive dies are required.

The individual stamped parts need to be assembled and fixtured to maintain dimensional accuracy during the welding process. The welding process creates localized heat affected zones where the material properties are substantially reduced. The welded assembly needs to be heat treated post-welding to restore the original material properties.

A single casting eliminates the need for multiple stampings, their related tools and fixtures and the need to post process heat treat the welded assembly. High pressure casting processes such as Thixomolding® and FATA Aluminum’s High Pressure Molding can be utilized to improve material properties for non-ferrous metals and allow thinner wall castings. The casting process also allows for variable wall thickness and molded in local reinforcements that contribute to a more optimized, lower mass part vs. a stamped and welded assembly.

This new body structure was designed in CAD using the above principles and then developed into a partial vehicle model (BIW with full suspension and powertrain), which was analyzed to determine the optimum materials to maximize structural rigidity while minimizing weight. The final body structure weighed 242 kg and the total vehicle mass was

1173 kg. Lotus carried over the EPA developed parallel hybrid powertrain used in the Phase 1 vehicle, which weighed 356 kg. The masses for all other vehicle systems were carried over from the Phase 1 High Development model and are listed in Table 4.2.5.a.

This mass-reduced and materially optimized vehicle was used to create the model for structural and crash simulations. Analyses were performed after every test to further optimize the vehicle's crash performance and to create a body structure with very high stiffness. A total of 27 discrete models, which included multiple updates based on the previous model results, were developed. In total, over several hundred design iterations were evaluated.

Lotus contracted Intellicosting (customers include most major OEMs and their suppliers) to analyze the body structure cost for the Phase 2 model as well as for the baseline Venza BIW. These cost studies are included in this report. Lotus also investigated the assembly process to ensure the low-mass BIW can be constructed. Lotus contracted EBZ, an international assembly plant design firm (customers include Audi, BMW, Ford of Europe and VW) to engineer a new body in white assembly plant to build the multi-material body. This study is included in the Appendix, including financials. The body structure development included design iterations developed to improve the build process, to minimize tooling and processing expenses and to reduce the cost of the body. This methodology is used by industry to develop production vehicles.

2.3. Results

This analysis applied state-of-the-art computer simulation modeling to develop and to determine if a lightweight and commercially feasible body structure for a mid-sized passenger car or crossover utility vehicle concept has the potential to meet or exceed the requirements for size, cargo volume, comfort, crashworthiness, and structural integrity. The mass-reduced vehicle's BIW structure, the primary vehicle system associated with overall passenger protection, was developed and evaluated in this study. The vehicle simulation indicated that a 32 percent mass-reduced vehicle with a 37 percent lighter body structure has the potential to meet U.S. federal impact requirements including side impacts and door beam intrusion (FMVSS 214), seatbelt loading (FMVSS 210), child tether loadings (FMVSS 213), front and rear end chassis frame load buckling stability, full frontal crash stiffness and body compatibility (FMVSS 208), and frame performance under low-speed bumper impact loads ('bumper A-surface offsets,') as defined by the Insurance Institute for Highway Safety.

2.4. Conclusions

This engineering study successfully achieved its objectives of designing a low mass CUV body structure that is feasible from an assembly standpoint, evaluating the crash performance of an over 30 percent mass-reduced vehicle and developing a theoretical model that demonstrates the potential to meet key structural and FMVSS/IIHS impact requirements. This was achieved through a holistic vehicle design. The vehicle design

targeted the dimensions of a 2009 Toyota Venza CUV. The Phase 2 multi-material body structure utilized relatively large quantities of advanced materials (e.g. advanced high-strength steels, aluminum, magnesium, and composites) and advanced joining and bonding techniques to achieve a substantial vehicular mass reduction without degrading size, utility or performance. Overall, vehicle body mass was reduced by 37 percent (141 kg), which contributed to a total vehicle mass reduction of 31 percent (527 kg) including the mass of other vehicle systems (interior, suspension, closures, chassis, etc.) which were optimized in a holistic redesign as part of the Phase 1 study. Additionally, this mass reduction was achieved using a parallel-hybrid drivetrain. It may be possible to further reduce total vehicle mass by using a lighter non-hybrid powertrain. Combining a 30% lighter vehicle with a 150 HP 1.0L three cylinder engine (Lotus is currently developing 145 Hp/L engines for OEM's) and reducing the Cd would result in substantial fuel savings while improving the weight/HP ratio of the baseline car.

This project used emerging technologies, advanced materials, state-of-the-art manufacturing and bonding techniques and innovative design to develop a low-mass vehicle that has the potential to meet or exceed modern vehicle demands in terms of functionality, safety, and structural integrity. The study developed a mass-reduced vehicle model and verified that it has the potential to achieve world class body stiffness and meet U.S. federal safety requirements as well as IIHS guidelines. This study indicates that it is technically feasible to develop a 30-percent lighter crossover vehicle without compromising size, utility, or performance and still meet regulatory and consumer safety requirements.

The mass-reduced design presented in this study resulted in an increased body-in-white cost, but a reduced overall vehicle cost. The BIW piece cost estimate is an increase of 160 percent – over \$700 – for the 37-percent mass-reduced body-in-white. This cost penalty decreases to \$239 when the estimated manufacturing and assembly costs are included in the analysis. This reduction is due to reduced tooling costs and to lower assembly costs. The use of lower cost tooling, such as extrusions, minimizing scrap by utilizing castings and pressure molded components, designing for less costly assembly methodologies such as friction spot joining and structural adhesive bonding, partially offset the cost of the more expensive light weight body. A significant reduction in the parts count, from 269 to 169, achieved by an increased level of component integration, also helped offset the increased body in white piece cost. The Phase 2 High Development total vehicle for the 2020 model year, including body and non-body components, achieves a 31-percent mass reduction along with an estimated cost reduction of one percent, including amortizing the cost of a new body plant over a three year period. This overall cost reduction is due to tooling and assembly savings and the cost reductions contributed by reduced mass non-body systems that were developed in the Phase 1 study.

This study illustrates how a holistic, total vehicle approach to system mass and cost reduction can help offset the additional cost of a 37 percent mass reduced body structure. This study also estimates how these mass reductions and costs scale to other vehicle classes; vehicles evaluated ranged from subcompact cars to full-sized, body on frame, light trucks.

This study's findings also indicate that the 30 percent mass-reduced vehicle could be cost-effectively mass-produced in the 2020 timeframe with materials and techniques technically feasible by 2017. The majority of the processes and materials for the Phase 2 model are in use today. Current production Lotus cars (Evora, Exige S) use many of the same materials and processes and Ford is targeting a similar process for their 2014 high volume F-150 pick up body structure (July 27, 2012, 12:01 AM Wall Street Journal). By factoring in the manufacturability of the materials and the processing and build sequencing of the parts in the assembly plant into the fundamental design process it is expected that a low mass multi-material body of this type can be production-ready in 2020 (with the possibility for earlier implementation) and that it will also have the potential for widespread commercialization in the 2025 timeframe.

2.5 Recommendations

A multi-material body structure should be built and tested to physically evaluate its structural characteristics for stiffness and modals (frequency response) using non-destructive testing methods.

Additionally, it is recommended that a low mass vehicle be constructed using the Lotus designed BIW presented in this study, fitted with components duplicating the non-body system masses, and then be evaluated for FMVSS impact performance and occupancy protection by NHTSA.

3. Glossary of Terms, Abbreviations, and Symbols

3D

Three dimensional. Something having three dimensions e.g. width, length, and depth.

5th Percentile Female

This represents a very small woman; 95 percent of women are larger than a 5th percentile female.

99th Percentile Male

This represents a very large man; this size man is larger than 98 percent of the male population.

A arm

In automotive suspension systems, a control arm (sometimes called a wishbone or A-arm) is a nearly flat and roughly triangular member (or sub-frame) that pivots in two places. The broad end of the triangle attaches at the frame and pivots on a bushing. The narrow end attaches to the steering knuckle and pivots on a ball joint.

'A' Pillar

An A pillar is a name applied by car stylists and enthusiasts to the shaft of material that supports the windshield (windscreen) on either of the windshield frame sides. By denoting this structural member as the A-pillar, and each successive vertical support in the greenhouse after a successive letter in the alphabet (B-pillar, C-pillar etc.), car designers and those interested in car design have common points of reference when discussing vehicle design elements.

ABS (material)

Acrylonitrile butadiene styrene (ABS) is a common thermoplastic used to make light, rigid, molded products.

Al or Alum.

Aluminum.

'B' pillar

See 'A' Pillar.

BH or Bake Hardenable Steel

A bake-hardenable steel is any steel that exhibits a capacity for a significant increase in strength through the combination of work hardening during part formation and strain aging during a subsequent thermal cycle such as a paint-baking operation.

A Segment

Vehicle classification used in Europe, equivalent to the American microcar and some subcompacts.

B Segment

Vehicle classification used in Europe, equivalent to the American subcompact.

C Segment

Vehicle classification used in Europe, equivalent to the American compact.

D Segment

Vehicle classification used in Europe, equivalent to the American midsize.

E Segment

Vehicle classification used in Europe, equivalent to the American fullsize

Belt Line

The beltline, also known as the waistline in the UK, is the horizontal or slightly inclined line below the side windows of a vehicle, starting from the hood and running to the trunk. It separates the glass area (the greenhouse) from the lower body.

BIW

BIW stands for body-in-white. All activities in the production of a vehicle body or shell before it goes to the paint shop are done in a weld shop and the end product of a weld shop is referred to as a BIW.

BOM

Bill of materials is a list of the raw materials, sub-assemblies, intermediate assemblies, sub-components, components, parts, cost, and the quantities of each needed to manufacture an end item (final product).

'C' Pillar

See 'A' Pillar.

C Segment

Vehicle classification used in Europe, equivalent to the American compact.

CAD

Computer-aided design is the use of computer technology for the design of objects, real or virtual.

CAE

Computer-aided engineering is the use of information technology to support engineers in tasks such as analysis, simulation, design, manufacturing, planning, diagnosis, and repair.

CARB or ARB

California Air Resources Board

CG

Center of gravity. The center of gravity or center of mass of a system of particles is a specific point where, for many purposes, the system behaves as if its mass were concentrated there.

Class A surface

A term used in automotive design to describe a set of freeform surfaces of high resolution and quality.

Closures

A term used to describe any aperture that can be opened on a vehicle. This includes doors, hoods, decklids and tailgates.

CO

Chemical shorthand for carbon monoxide – a colorless, odorless, and tasteless, yet highly toxic gas. Exists as a gas in Earth's atmosphere at standard temperature and pressure.

CO₂

Chemical shorthand for carbon dioxide, a chemical compound composed of two oxygen atoms covalently bonded to a single carbon atom. It is a gas at standard temperature and pressure and exists in Earth's atmosphere in this state.

Composite

Composite materials are engineered materials made from two or more constituent materials with significantly different physical or chemical properties which remain separate and distinct on a macroscopic level within the finished structure.

CSA

Cross sectional area. In geometry, a cross-section is the intersection of a body in 2-dimensional space with a line, or of a body in 3-dimensional space with a plane, etc. More plainly, when cutting an object into slices one gets many parallel cross-sections.

CUV

Crossover utility vehicle. Crossover is a marketing term for a vehicle derived from a car platform but borrows features from a Sport Utility Vehicle (SUV).

'D' Pillar

See 'A' Pillar.

DLO

Daylight opening. Automotive industry term for glassed-in areas of a vehicle's cabin

DP or Dual Phase Steel

Dual-phase steel (DPS) is a high-strength steel that has a ferrite and martensitic microstructure. DPS starts as a low or medium carbon steel and is quenched from a temperature above A1 but below A3 on a continuous cooling transformation diagram. This

results in a microstructure consisting of a soft ferrite matrix containing islands of martensite as the secondary phase (martensite increases the tensile strength). The desire to produce high strength steels with formability greater than micro-alloyed steel led the development of DPS in the 1970s.

EPA

United States Environmental Protection Agency.

FEA

Finite element analysis. A computational method of stress calculation in which the component under load is considered as a large number of small pieces ('elements'). The FEA software is then able to calculate the stress level in each element, allowing a prediction of deflection or failure

FEM

Front end module. An assembly or complex structure which includes the content of what was previously multiple separate parts.

FMVSS

FMVSS is the acronym for Federal Motor Vehicle Safety Standard. FMVSS norms are administered by the United States Department of Transportation's National Highway Traffic Safety Administration.

FR plastic

Fiber reinforced plastic. Fiber-reinforced plastics (FRP) (also fiber-reinforced polymer) are composite materials made of a polymer matrix reinforced with fibers.

Frt

Front

FWD

Front-wheel drive is a form of engine/transmission layout used in motor vehicles, where the engine drives the front wheels only.

GAWR

Gross axle weight rating is the maximum distributed weight that may be supported by an axle of a road vehicle. Typically GAWR is followed by either the letters F, FR, R or RR which indicate Front or Rear axles.

GVW or GVWR

A gross vehicle weight rating is the maximum allowable total weight of a road vehicle or trailer when loaded - i.e., including the weight of the vehicle itself plus fuel, passengers, cargo, and trailer tongue weight.

HIC

Head injury criterion. The head injury criterion is a measure of the likelihood of head injury arising from an impact.

HP

Horsepower (hp or HP or Hp) is the name of several non-SI units of power. One mechanical horsepower of 550 foot-pounds per second is equivalent to 745.7 watts.

HSS

High strength steel is low carbon steel with minute amounts of molybdenum, niobium, titanium, and/or vanadium. Is sometimes used to refer to high strength low alloy steel (HSLA) or to the entire group of engineered alloys of steels developed for high strength. .

ICE

Internal combustion engine. The internal combustion engine is an engine in which the combustion of a fuel occurs with an oxidizer (usually air) in a combustion chamber.

IIHS

The Insurance Institute for Highway Safety is a U.S. non-profit organization funded by auto insurance companies. It works to reduce the number of motor vehicle crashes, and the rate of injuries and amount of property damage in vehicle crashes. It carries out research and produces ratings for popular passenger vehicles as well as for certain consumer products such as child car booster seats.

ISOFIX

The international standard for attachment points for child safety seats in passenger cars. The system is also known as LATCH ('Lower Anchors and Tethers for Children') in the United States and LUAS ('Lower Universal Anchorage System') or Canfix in Canada. It has also been called the 'Universal Child Safety Seat System' or UCSSS.

IP

Instrument panel. A dashboard, dash, 'dial and switch housing' or fascia, (chiefly in British English) is a control panel located under the windshield of an automobile. It contains the instrumentation and controls pertaining to the operation of the vehicle. During the design phase of an automobile, the dashboard or instrument panel may be abbreviated as 'IP'.

kg

Kilogram, unit of weight, 1 kg = 2.205 pounds.

kW

The kilowatt, equal to one-thousand watts, is typically used to state the power output of engines and the power consumption of tools and machines. A kilowatt is approximately equivalent to 1.34 horsepower.

kWh

The kilowatt hour, or watt-hour, (symbol W·h, W h) is a unit of energy equal to 3.6 kilojoules. Energy in watt hours is the multiplication of power in watts and time in hours.

LATCH

Lower Anchors and Tethers for Children. See ISOFIX.

LCA

Lower control arm. See A arm.

LF

Left Front, e.g. left front door.

LH

Left hand

m³ or m3 or m³

Meters cubed or cubic meters, measure of volume.

mJ

Millijoules. The joule (symbol J), named for James Prescott Joule, is the derived unit of energy in the International System of Units. It is the energy exerted by a force of one newton acting to move an object through a distance of one metre. 1 mJ = 2.77x10⁻⁷ Watt hours.

mm

Millimeters, unit of length, 1 mm = 0.03937 inches.

Monocoque

Monocoque, from Greek for single (mono) and French for shell (coque), is a construction technique that supports structural load by using an object's external skin as opposed to using an internal frame or truss that is then covered with a non-load-bearing skin. Monocoque construction was first widely used in aircraft in the 1930s. Structural skin or stressed skin are other terms for the same concept. Unibody, or unitary construction, is a related construction technique for automobiles in which the body is integrated into a single unit with the chassis rather than having a separate body-on-frame. The welded 'Unit Body' is the predominant automobile construction technology today.

LWR

Lower

Mg

Magnesium

Modal

Modal refers to the natural frequency of a specific point on a vehicle structure, e.g., a seat mount; it is essential that the modal frequency be separated from vehicle input frequencies so that suspension inputs and powertrain responses do not excite structural elements at their natural frequency causing vibrations.

MPa

Mega Pascals, unit of pressure or stress, 1 MPa = 145 Pounds per square inch.

MPV

Multi-purpose vehicle, people-carrier, people-mover or multi-utility vehicle (shortened MUV) is a type of automobile similar in shape to a van that is designed for personal use. Minivans are taller than a sedan, hatchback or a station wagon, and are designed for maximum interior room.

MS

Mild steel or Carbon steel, also called plain carbon steel, is steel where the main alloying constituent is carbon.

MSRP

The (manufacturer's) suggested retail price, list price or recommended retail price (RRP) of a product is the price the manufacturer recommends that the retailer sell it for.

MY

Model year. The model year of a product is a number used worldwide, but with a high level of prominence in North America, to describe approximately when a product was produced, and indicates the coinciding base specification of that product.

NCAP

The European New Car Assessment Program (Euro NCAP) is a European car safety performance assessment program founded in 1997 by the Transport Research Laboratory for the UK Department for Transport and now the standard throughout Europe.

NHTSA

The National Highway Traffic Safety Administration (NHTSA, often pronounced 'nit-suh') is an agency of the Executive Branch of the U.S. Government, part of the Department of Transportation.

NO_x

NO_x is a generic term for mono-nitrogen oxides (NO and NO₂).

NPI

New product introduction.

NVH

Noise, vibration, and harshness (NVH), also known as noise and vibration (N&V), is the study and modification of the noise and vibration characteristics of vehicles, particularly cars and trucks.

OD

Outer diameter. Outside diameter of a circular object.

OEM

Original equipment manufacturer. The OEM definition in the automobile industry constitutes a federally-licensed entity required to warrant and/or guarantee their products, unlike 'aftermarket' which is not legally bound to a government-dictated level of liability.

OTR

Outer

PA

Polyamide, a polymer containing monomers of amides joined by peptide bonds. They can occur both naturally, examples being proteins, such as wool and silk, and can be made artificially through step-growth polymerization, examples being nylons, aramids, and sodium poly(aspartate).

PC

Polycarbonates are a particular group of thermoplastic polymers.

PHEV

A plug-in hybrid electric vehicle (PHEV) is a hybrid vehicle with batteries that can be recharged by connecting a plug to an electric power source. It shares the characteristics of both traditional hybrid electric vehicles (also called charge-maintaining hybrid electric vehicles), with an electric motor and an internal combustion engine, and of battery electric vehicles, also having a plug to connect to the electrical grid (it is a plug-in vehicle).

PP

Polypropylene or polypropene is a thermoplastic polymer, made by the chemical industry and used in a wide variety of applications.

PPO

Poly(p-phenylene oxide), is a high-performance polymer and an engineering thermoplastic.

PU or PUR

Polyurethane

PVC

Polyvinyl chloride, (IUPAC Poly(chloroethanediyl)) commonly abbreviated PVC, is the third most widely used thermoplastic polymer after polyethylene and polypropylene.

QTR
Quarter

Rad
Radiator

Reinf
Reinforcement
RF
Right Front, as for right front door.

RH
Right hand

ROM
Rough order of magnitude. Term used in analysis equating to 'Estimate'

RR
Rear

RWD
Rear-wheel drive is a form of engine/transmission layout used in motor vehicles, where the engine drives the rear wheels only.

SLA
A Short-long arm suspension is also known as an unequal length double wishbone suspension. The upper arm is typically an A-arm, and is shorter than the lower link, which is an A-arm or an L-arm, or sometimes a pair of tension/compression arms. In the latter case the suspension can be called a multi-link, or Dual ball joint suspension.

Strain energy density
Strain energy density is a measurement of the material deflection that occurs when a component is loaded with a force or torque

Stress
Stress is the relationship between strain and the material modulus and is defined as force divided by unit area (stress = strain x material modulus)

System
Nine separate system categories were created that included all vehicle components. The systems are: body structure, closures, front and rear bumpers, glazing, interior, chassis/suspension, air conditioning, electrical/lighting and powertrain.

Sub-system
A major assembly within a given system, e.g., a seat is a sub-system in the Interior system

SUV

A sport utility vehicle is a generic marketing term applied to some unibody and body-on-frame light trucks and station wagons.

Topology analysis

A means of determining strain energy densities for a CAD model with defined interior and exterior dimensions. This methodology creates relative strain energy densities as a function of the available geometry and material utilized. This analysis is used to minimize material utilization and to maximize section inertias based on the material strain energy densities and the section geometry.

TRIP steel

TRIP steel is a high-strength steel typically used in the automotive industry. TRIP stands for 'transformation induced plasticity.' TRIP steel has a triple phase microstructure consisting of ferrite, bainite, and retained austenite. During plastic deformation and straining, the metastable austenite phase is transformed into martensite. This transformation allows for enhanced strength and ductility.

TRL

TRL is an acronym for 'Technology Readiness Level'. TRL is defined, for the purposes of this study, as a technology that is considered feasible for volume production at the inception of a new vehicle program, i.e., approximately 3 years prior to start of production. The technology may be proven at the time of the new vehicle program start or is expected to be proven early in the production design process so that there is no risk anticipated at the targeted timing for production launch.

UHSS

UHSS stand for ultra high strength steel – dual phase UHSS typically has tensile strengths from 500 MPa to 1000 MPa while low carbon martensite has tensile strengths ranging from 800 MPa to 1500 MPa (based on published Auto Steel Partnership definitions)

US or U.S.

United States of America

UTS

Ultimate tensile strength.

V

The volt is the SI derived unit of electromotive force, commonly called 'voltage'.

Whse

Wheelhouse

YS

Yield strength or yield point of a material is defined in engineering and materials science as the stress at which a material begins to deform plastically.

4. Report: Demonstrating the Safety and Crashworthiness of a 2020 Model-Year, Mass-Reduced Crossover Vehicle

4.1. Introduction

In response to concerns about the impact of climate change on the economy and the health and welfare of its citizens, the State of California has taken steps to reduce greenhouse gas (GHG) emissions from the vehicle fleet as part of the larger effort to reduce GHG emissions from the state as a whole. To that end, California passed The Global Warming Solutions act of 2006 (known as AB 32) in an attempt to reduce GHG emissions to 1990 levels by 2020. Additionally, 2005 Executive Order S-3-05 set a target for an 80-percent reduction in GHG emissions from 1990 levels by 2050. These policies were preceded by California's 2002 legislation, which led to the Pavley standards (named after the author of AB 1493) for light-duty vehicle GHG emissions. One approach to reducing vehicular GHG emissions not considered in the Pavley Standards is vehicle mass reduction by combining lightweight materials and innovative vehicle design. Emerging research and technical papers, along with recent auto industry developments, suggest that materials such as composites, high strength steels, aluminum, magnesium, and the latest adhesives integrated into innovative structures can yield substantial weight savings. The implications are that this can be done while maintaining or improving current vehicle characteristics – including safety, noise, vibration, and harshness (NVH) control, durability, handling, interior volume, utility, and load carrying capacity – while still meeting current FMVSS and IIHS safety requirements.

Lotus responded to the Air Resources Board RFP 09-621 entitled 'Computer Simulation to Optimize the Design of a Lightweight Light-Duty Vehicle and Demonstrate its Crashworthiness' with a proposal to develop a solution to substantially reduce body structure mass relative to a current production crossover utility vehicle (CUV) in a cost effective manner for the 2020 – 2025 timeframe. The baseline CUV, a 2009 Toyota Venza, established the geometric and volumetric parameters as well as the reduced mass target. The low-mass vehicle maintained the same interior and cargo volume as the baseline vehicle. CARB contracted Lotus to initiate this study in July 2010.

Key features of this proposal included: 1. developing a topology analysis using key inputs of the proposed body to develop optimized load paths for structure and impact performance using a 3D CAD model and finite element analysis; 2. generating a representative total vehicle model including system masses (less powertrain) and 3. creating a CAD model of the topology-developed body structure. This optimized and meshed model served as the starting point for the FEA impact and structural studies including front, rear and side impact, roof crush, seatbelt and tether loadings, and low speed bumper impact strains. Altair/OptiStruct[®] software was used for the topology analysis.

The tests evaluated in this study were:

- FMVSS 208: Front Impact (0°/30° rigid wall, offset deformable barrier)
- FMVSS 210: Seatbelt Anchorages
- FMVSS 213: Child Restraint Systems
- FMVSS 214: Side Impact (side barrier, side pole)
- FMVSS 216: Roof Crush
- FMVSS 301: Rear Impact (moving deformable barrier)
- IIHS: Low Speed Bumper (front & rear)

LS-DYNA[®] software was used for all impact analysis.

Additionally, MSC/Nastran[®] software was used to analytically verify body stiffness.

The target weight was a minimum of 30-percent mass reduced vehicle relative to the baseline 2009 Toyota Venza, less powertrain.

The topology-based CAD model was refined through multiple iterations to meet the impact and structural requirements while minimizing body structure mass. The final model update is V26 (without closures) and V27 (with closures); several hundred iterations were performed to develop these models. An initial Bill of Materials (BOM) was created and revised throughout the modelling process to reflect component updates. The BOM included mass, cost, and material for all body structure components. A final BOM is included in this report in Section 4.5.5.a. An analysis examining the potential to extrapolate the low mass CUV results to other vehicle classes was also performed as part of this study and is included in Section 4.5.8.

This study utilized Lotus' methodology for engineering a low mass vehicle, which includes: 1. creating efficient load paths; 2. component integration and part elimination; 3. structural enhancements through optimized section inertias, an exponential function, vs. wall thickness increases, a linear function; 4. defining the minimum crush length targets at program initiation; 5. selecting world class suppliers experienced in low mass materials, structural reinforcements, joining technologies, coatings, adhesives, costing and manufacturing to provide input on the design feasibility and cost feedback for the Lotus low mass body structure and 6. mass decompounding in key areas, such as the chassis/suspension, as a direct result of reduced mass in other vehicle systems.

4.2. Materials and Methods

The following table lists all the tasks as described in Lotus' contract with CARB, the method Lotus used to complete the task, and the final deliverable product.

Table 4.2.a: Overview of the report and tasks

| Task 1: Develop a Mass Reduced Body Structure Model | | |
|---|---|---|
| Task | Method | Deliverable |
| Package study with respect to chassis frame interfaces | <ul style="list-style-type: none"> •Total vehicle package layout defined •Critical interfaces and functions of current structure defined | <ul style="list-style-type: none"> •Major structure interfaces identified •Effective structural package design space defined |
| FE topology analysis | <ul style="list-style-type: none"> •Optimization performed using FEA tools with respect to crash load paths and frame bending/torsion load paths •Optimization to identify the structural efficiencies within the package design space | <ul style="list-style-type: none"> •Mass efficient structural load paths and initial section moduli defined in FE environment for output to CAD |
| CAD geometry generation for CAE optimization | <ul style="list-style-type: none"> •From identified structurally efficient load paths, generate concept design feasible sections with respect to package output to hybrid beam shape optimization | <ul style="list-style-type: none"> •CAD model of initial structural concept and section routing created using FEA results •Concept design layout defines manufacturing and technology to be used based on required section shapes and sizes as well as package and cost |
| Crash structure sizing | <ul style="list-style-type: none"> •Front and rear crash structure energy absorption requirements using projected vehicle mass •Energy management strategy devised to suit package and vehicle architecture | <ul style="list-style-type: none"> •Front and rear crash structures sized with respect to energy absorption requirement and strategy •3D CAD models of concept body structure design |
| Concept CAD design generation | <ul style="list-style-type: none"> •CAD design of body structure created with respect to FEA sizing results and package •CAD generation and design updated in conjunction with FEA analysis | <ul style="list-style-type: none"> •Manufacturing technology to be used is defined with respect to commercial and technical objectives |
| Detailed FEA chassis frame model build | <ul style="list-style-type: none"> •Detailed FEM built using initial concept CAD model •Critical interfaces with carryover components included | <ul style="list-style-type: none"> •Detailed FEM of CAD body structure and associated body structural components modeled •Model continually updated during concept design phase |
| Static stiffness/joint sensitivity analysis | <ul style="list-style-type: none"> •Static torsion and bending stiffness tuned in FE environment to achieve target requirements to support NVH and vehicle ride and handling objectives •Joint sensitivity and development conducted in FE environment •Continual feedback loop to CAD design | <ul style="list-style-type: none"> •Static torsion and vertical/lateral bending stiffness status for body/chassis structure for concept design phase |
| Dynamic body structure modal analysis | <ul style="list-style-type: none"> •Chassis/body structural modes analyzed and structure developed to achieve target modal frequencies required to give predicted trimmed body modal response •Global chassis design/body shapes identified as well as local front and rear end modes between 20-150 Hz | <ul style="list-style-type: none"> •Chassis/body major mode frequencies predicted |
| Task 2: Initial Demonstration of Crashworthiness of 30% Mass Reduced Vehicle | | |
| Generate detailed FEA model | <ul style="list-style-type: none"> •Consolidate Task 1 result into a vehicle body structure model •Consolidate Task 1 results into a 30-percent mass reduced total vehicle, less powertrain | <ul style="list-style-type: none"> •Generate body-in-white model to be used for FMVSS and IIHS modeling |

| | | |
|---|--|---|
| Side intrusion FMVSS 214 section sizing | <ul style="list-style-type: none"> •FE analysis used to determine critical section requirements to achieve side impact intrusion/energy absorption •Requirements for door mounting support structure determined and A/B pillar structure sections sized accordingly | <ul style="list-style-type: none"> •Door beam intrusion velocities and displacement targets predicted. Rocker beam structural stability achieved to facilitate high confidence in achieving required side impact occupant injury level criteria |
| FMVSS 210/213 | <ul style="list-style-type: none"> •Seatbelt and child tether anchorage loads analyzed and efficient structural load path back into main frame structure devised | <ul style="list-style-type: none"> •Chassis structure validated for seatbelt anchorage and child tether loadings |
| Front and rear sub-system crash FEA | <ul style="list-style-type: none"> •FE validation of front crash structure sizing conducted during initial chassis architecture concept layout phase using hybrid model with body representation and detailed energy absorbing structure •FE validation of rear crash structure sizing conducted during initial chassis architecture concept layout phase using hybrid model with body representation and detailed energy absorbing structure •Recovery of loads into main structure in order to determine main structure in order to determine main structure strength requirement for non-deformation during crash (front and rear) | <ul style="list-style-type: none"> •Section sized for front and rear crash structure •Chassis frame end load buckling stability determined |
| Full vehicle frontal crash analysis FMVSS 208 | <ul style="list-style-type: none"> •Using crash structure defined via hybrid model analysis and chassis structure sized through durability/NVH and static stiffness •Carryout analysis to confirm compatibility of main chassis structure with rear energy absorbing sub-system | <ul style="list-style-type: none"> •Section sizes for front crash structures defined •Chassis frame rocker beams and passenger compartment structure section sizes defined to give adequate support to crash structure |
| Rear crash analysis (using FMVSS 301 as protocol) | <ul style="list-style-type: none"> •Using crash structure defined via hybrid model analysis and chassis structure sized through durability/NVH and static stiffness •Carryout analysis to confirm compatibility of main chassis structure with rear energy absorbing sub-system | <ul style="list-style-type: none"> •Section sizes for front crash structures defined •Chassis frame rocker beams and passenger compartment structure section sizes defined to give adequate support to crash structure |
| Structure validation for low speed bumper impact loads (IIHS) | <ul style="list-style-type: none"> •Using bumper A-surface offsets and generic peak loading expected for low speed and pendulum impacts, validate frame structure to minimize plastic strain | <ul style="list-style-type: none"> •Frame structure sized to give adequate support to bumper impact loads via A-surface offsets |
| Roof crush FMVSS 216 | <ul style="list-style-type: none"> •Roof crush resistance over the passenger compartment analyzed and efficient structural load paths devised | <ul style="list-style-type: none"> •Body structure validated for roof crush displacement |
| Trimmed chassis/body FEA model build | <ul style="list-style-type: none"> •Chassis/body structure FE model updated using CAD and FEA output from concept design phase •Trimmed body model produced that includes all major body structural and non-structural masses along with chassis and powertrain representations •Crash models generated from master model | <ul style="list-style-type: none"> •Trimmed chassis/body FE model produced for use with crash analysis. Model to include all relevant sub-systems |
| Front impact FE crash analysis | <ul style="list-style-type: none"> •Front crash FE analysis carried out on base model •Crash analyses conducted: <ul style="list-style-type: none"> -FMVSS 208 -FMVSS 208/40% OBD (35 mph) •Crash analyses conducted to validate the following areas: <ul style="list-style-type: none"> -Acceleration pulse analyzed and tuned to meet selected target -Passenger compartment intrusion •Compare pulse results to baseline vehicle using public domain test results | <ul style="list-style-type: none"> •Body structure CAE validated to attain target crash acceleration pulse and intrusion level targets •Body structure crash performance validated to provide good basis for restraint system to achieve legislative occupant injury criteria |
| Side impact FE crash analysis | <ul style="list-style-type: none"> •Side impact FE analysis to validate vehicle frame design for generic acceleration pulse and intrusion requirements •Crash analyses: <ul style="list-style-type: none"> -FMVSS 214 oblique pole -FMVSS 214 deformable barrier (33.5 mph) | <ul style="list-style-type: none"> •Body structure validated to attain target side impact acceleration pulse and intrusion level targets •Body structure crash performance validated to provide acceptable basis for restraint/interior trim system to achieve legislative occupant injury criteria |

| | | |
|---|---|---|
| Rear impact FE crash analysis | <ul style="list-style-type: none"> •Rear crash FE analysis carried out on base model •Crash analysis conducted to validate the following areas: <ul style="list-style-type: none"> -Acceleration pulse analyzed and tuned to meet internal target -General crush distances and impact on fuel system integrity | <ul style="list-style-type: none"> •Body structure validated to attain target fuel system integrity and intrusion level targets consistent with federal requirements |
| Finalized engineering CAD design | <ul style="list-style-type: none"> •Design of body structure completed •Body structure ready for tooling release phase •Plant processing defined •Costed bill of materials completed | <ul style="list-style-type: none"> •Final CAD design that meets analysis and vehicle integration functions and is feasible from a processing standpoint •Mass reduction summary vs. baseline completed •Cost impact summary vs. baseline completed |
| Task 3: Develop Engineering Bill of Materials | | |
| Develop engineering bill of materials | <ul style="list-style-type: none"> •Create bill of materials tracking: 1. body structure, 2. materials, 3. cost with supporting data •Utilize bill of materials to track parts, cost, mass, and materials throughout project | <ul style="list-style-type: none"> •Create initial bill of materials early in program and update on regular basis •Create final bill of materials based on optimized and validated body structure and compare to baseline |
| Task 4: Extension of Results to Other Vehicle Classes | | |
| Extrapolate design results into other vehicle sizes and classes | <ul style="list-style-type: none"> •Provide guidance on using developed body structure for other vehicle size and weight classes •Provide guidance on materials, components, sub-systems, systems, and processes relative to utilization on other vehicle classes | <ul style="list-style-type: none"> •Create a bill of materials study extrapolating finalized CUV body structure into other vehicle classes with feasibility analysis discussion document |
| Reporting | | |
| <ul style="list-style-type: none"> •Provide bi-monthly progress reports •Provide interim reports at the end of each of the four tasks •Provide final report draft ninety days prior to contract termination date •Provide amended final report using State input within 45 days or earlier following receipt of State comments •Deliver State-approved amended final report in multi-media form within two weeks of State approval | | |

4.2.1. Model Creation

Lotus created the body of this 'Phase 2' vehicle model using the exterior styling and other non-body components from the 2010 Lotus High Development vehicle, referred to as the 'Phase 1' design. Figures 4.2.1.a and 4.2.1.c show the front and rear exterior design, which is derived from the baseline Toyota Venza shown in Figures 4.2.1.b and 4.2.1.d. The Phase 1 High Development vehicle served as the basis for the CAD design and individual components were developed based on the Phase 1 HD body and assigned part numbers. These parts created the basis for the BOM included in Section 4.5.5.a. The BIW CAD part numbering has been incorporated – with some modification – into the CAE model to cross-reference the parts listed in the BOM. As an example the Panel Body-side Outer LH has a CAD part ID 7306-2300-185; the equivalent CAE part id is #231850 (station id, last three numbers from part id, plus additional 0 to allow for multiple gauge definitions). Parts in the CAE model that need to be defined with a heat affected zone material definition are in the 1,000,000 range (i.e. CAE part 231850 heat affected zone ID 1231850). Unless otherwise noted as the baseline Venza or the Phase 1 design (both of which are referenced for context herein), the diagrams, text, and results in this study are of the Phase 2 design.



Figure 4.2.1.a: Phase 1 High Development Model Exterior Styling – Front



Figure 4.2.1.b: Baseline Toyota Venza Exterior Styling – Front



Figure 4.2.1.c: Phase 1 High Development Model Exterior Styling – Rear



Figure 4.2.1.d: Baseline Toyota Venza Exterior Styling – Rear

The complete vehicle model is broken down into sub-models, which were also used for CAE analysis, as follows:

4.2.1.1. BIW

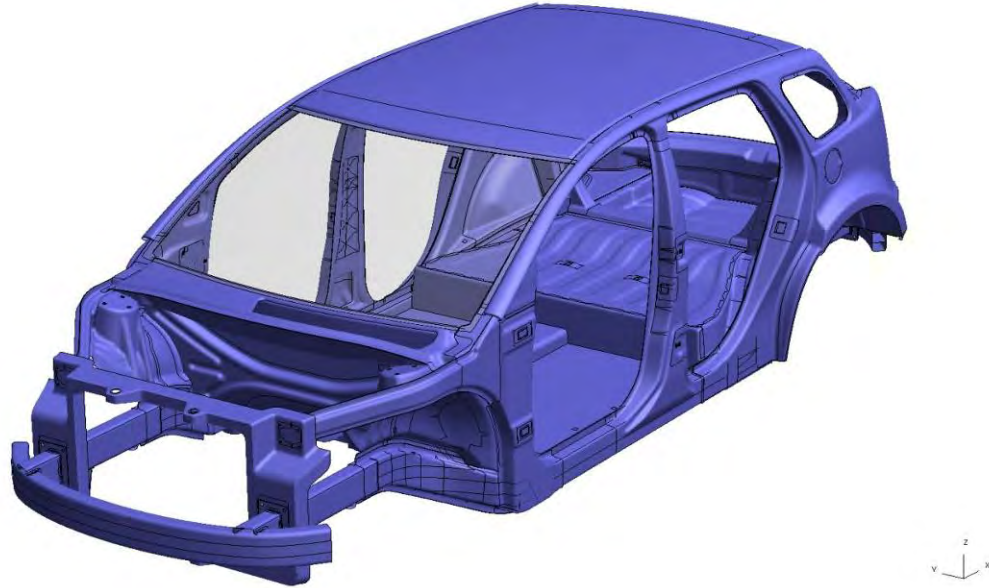

Figure 4.2.1.1.a: Body-in-white – Front

4.2.1.2. Simulated Doors (beams only)

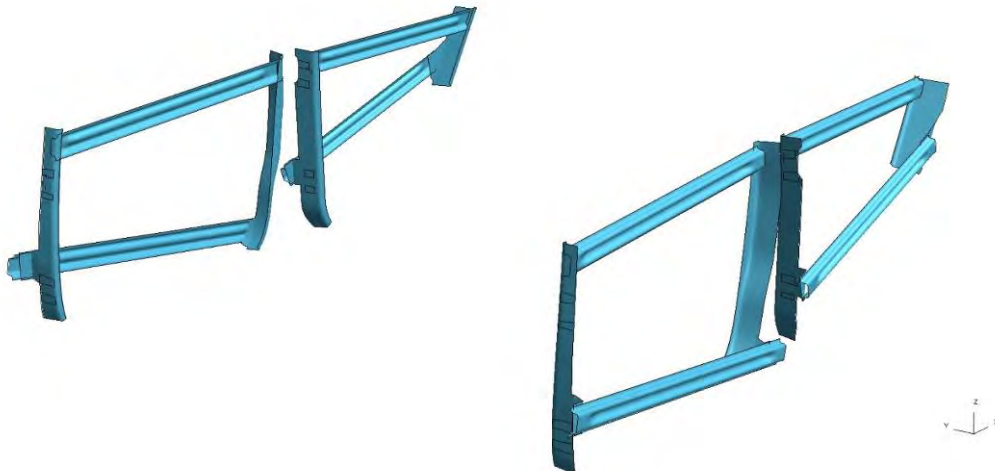

Figure 4.2.1.2.a: Simulated door beams

4.2.1.3. Front Sub-frame/Suspension

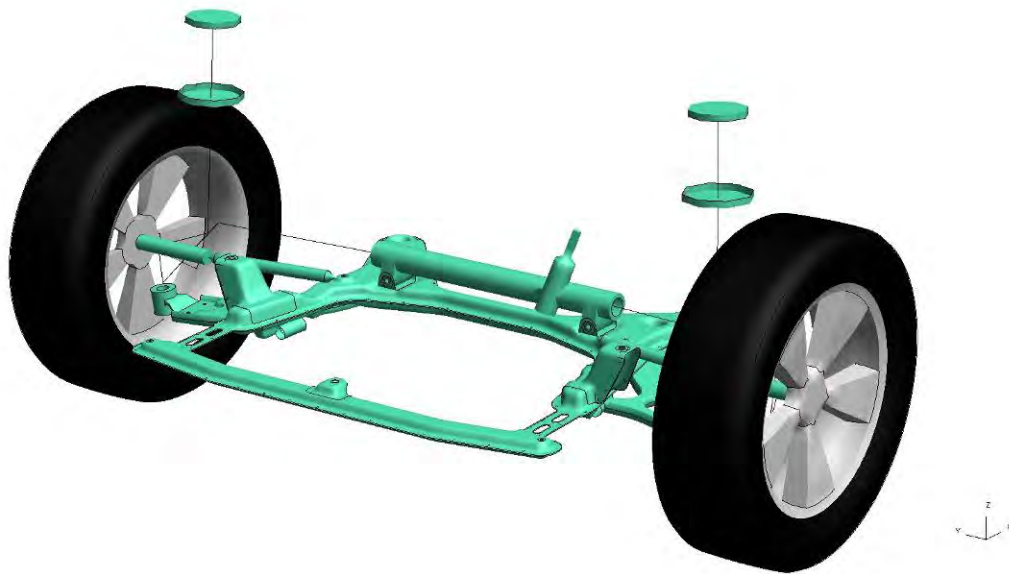

Figure 4.2.1.3.a: Front sub-frame and suspension

4.2.1.4. Rear Sub-frame/Suspension



Figure 4.2.1.4.a: Rear sub-frame and suspension

4.2.1.5. Cooling Pack/Front Under Hood

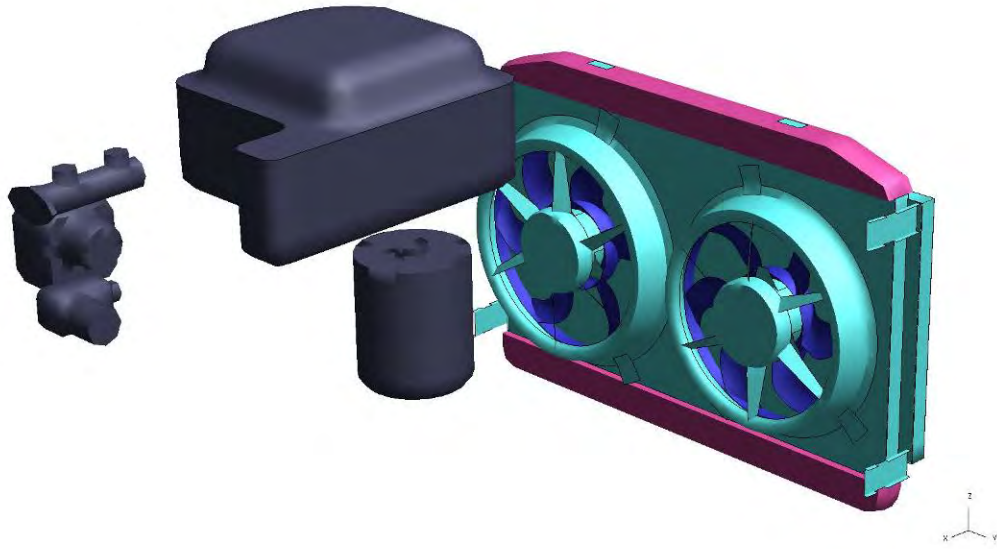

Figure 4.2.1.5.a: Cooling and under hood

4.2.1.6. Powertrain/Exhaust

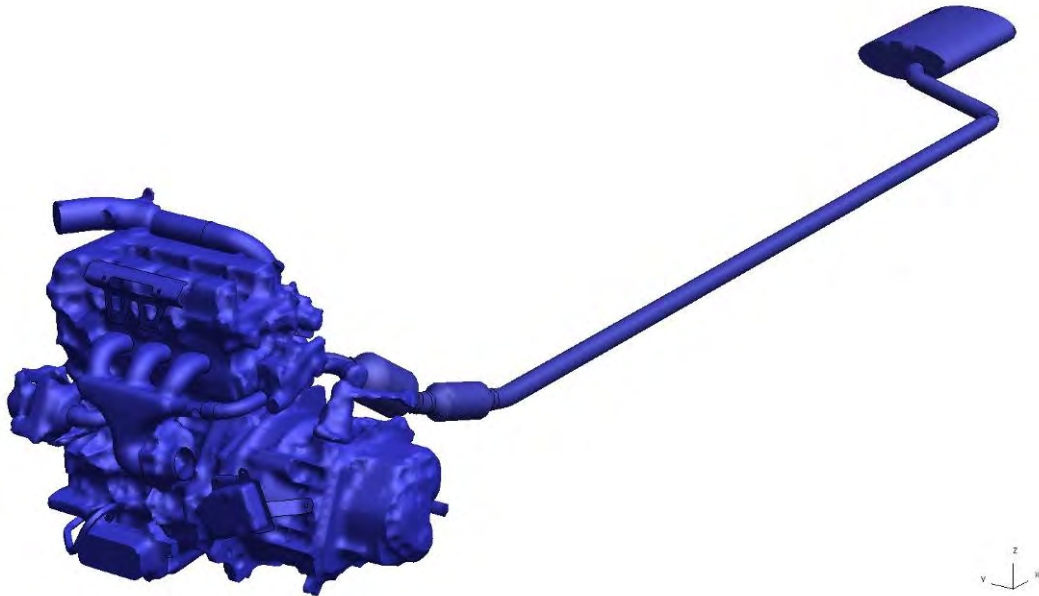

Figure 4.2.1.6.a: Powertrain and exhaust

4.2.1.7. Fuel Tank/Battery

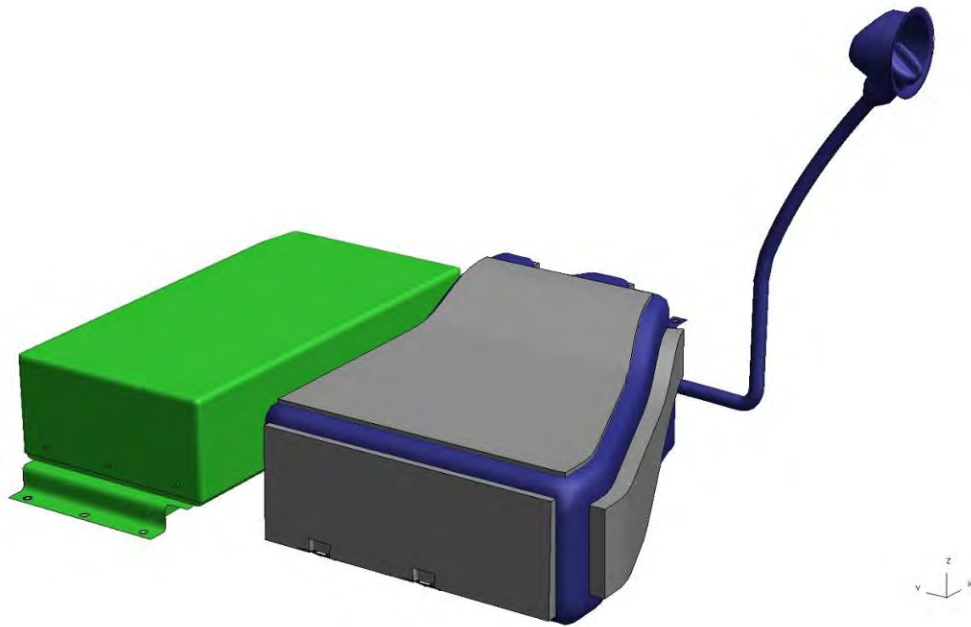

Figure 4.2.1.7.a: Fuel tank/battery

4.2.2. Material Data

The vehicle design incorporated a number of different material types. Physical properties were provided by Alcoa, Allied Composite Technologies, Henkel and Meridian for their respective materials: aluminum, composites, adhesives/mastics/composites/coatings and magnesium. Additionally, Alcoa, Henkel, Meridian and Kawasaki (Friction Spot Joining – FSJ - process) collaborated with Lotus to construct coupons that were destructively tested in the Henkel laboratory to provide input for the FEA model. The coupons included adhesively bonded joints and FSJ joints. These results were incorporated into the CAE model simulations.

4.2.2.1. Steel

HSLA - Generic (Matweb):
Young's Modulus (E) = 210,000MPa
Poisson's Ratio (ν) = 0.3
Yield Stress (σ_y) = 300MPa
Density (ρ) = $7.8e^{-9}$ tonnes/mm³

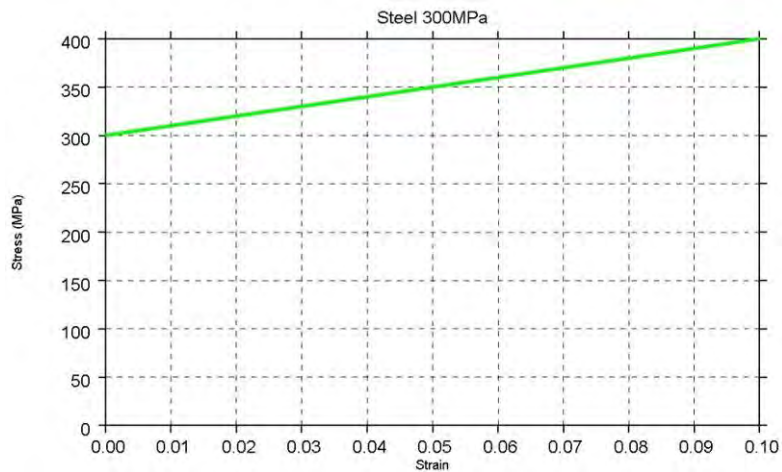

Figure 4.2.2.1.a: Steel stress-strain curve at 300 MPa

400MPa - Generic (Matweb):
Young's Modulus (E) = 210,000MPa
Poisson's Ratio (ν) = 0.3
Yield Stress (σ_y) = 400MPa
Density (ρ) = $7.8e^{-9}$ tonnes/mm³

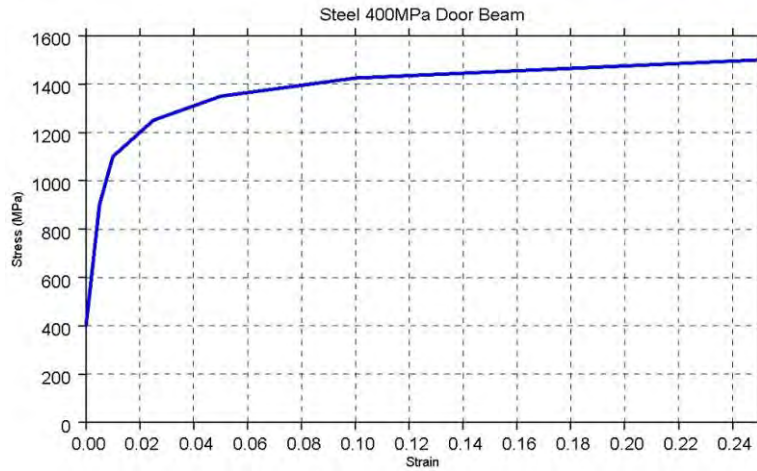
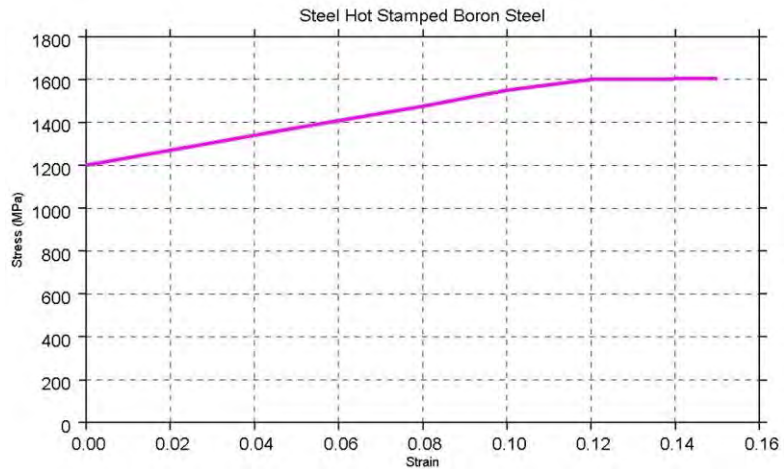

Figure 4.2.2.1.b: Steel stress-strain curve at 400 MPa

Hot Stamped Boron - Generic (Matweb):
Young's Modulus (E) = 210,000MPa
Poisson's Ratio (ν) = 0.3
Yield Stress (σ_y) = 400MPa
Density (ρ) = $7.8e^{-9}$ tonnes/mm³



4.2.2.1.c: Hot-stamped, boron steel stress-strain curve

4.2.2.2. Aluminum

AL 6013-T6 (Alcoa, Ed Forsythe 10/09/27):

Young's Modulus (E) = 70,000MPa

Poisson's Ratio (ν) = 0.33

Yield Stress (σ_y) = 360MPa

Density (ρ) = $2.79e^{-9}$ tonnes/mm³

Stress vs. Plastic Strain (i.e. post yield) as per following curve

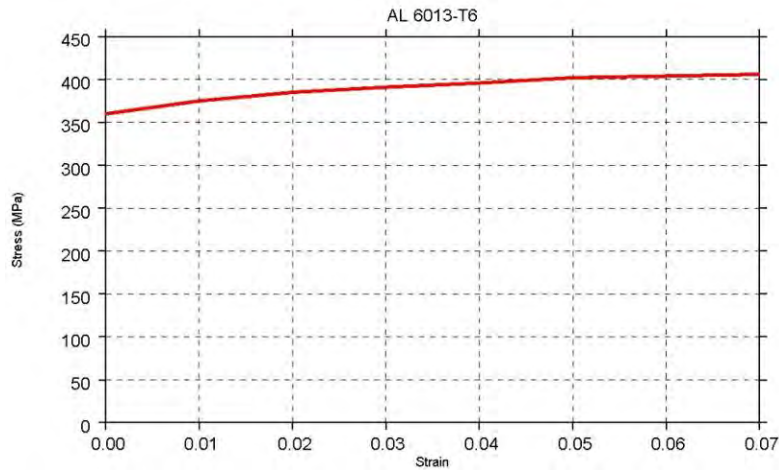

Figure 4.2.2.2.a: 6013 aluminum stress-strain curve

AL 6022-T4 plus 20min Paint Bake @ 170°C (Alcoa, Ed Forsythe 10/09/27):

Young's Modulus (E) = 70,000MPa

Poisson's Ratio (ν) = 0.33

Yield Stress (σ_y) = 172MPa

Density (ρ) = $2.79e^{-9}$ tonnes/mm³

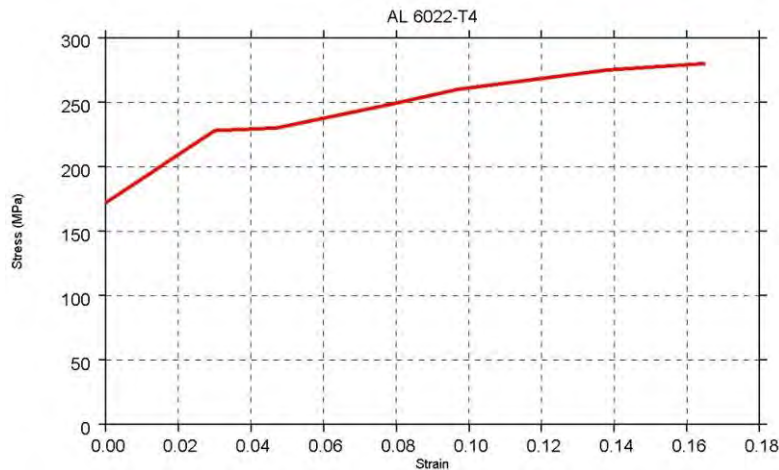

Figure 4.2.2.2.b: 6022 aluminum stress-strain curve

AL 6061-T6 (Alcoa, Ed Forsythe 10/09/23):
Young's Modulus (E) = 70,000MPa
Poisson's Ratio (ν) = 0.33
Yield Stress (σ_y) = 308MPa
Density (ρ) = $2.79e^{-9}$ tonnes/mm³

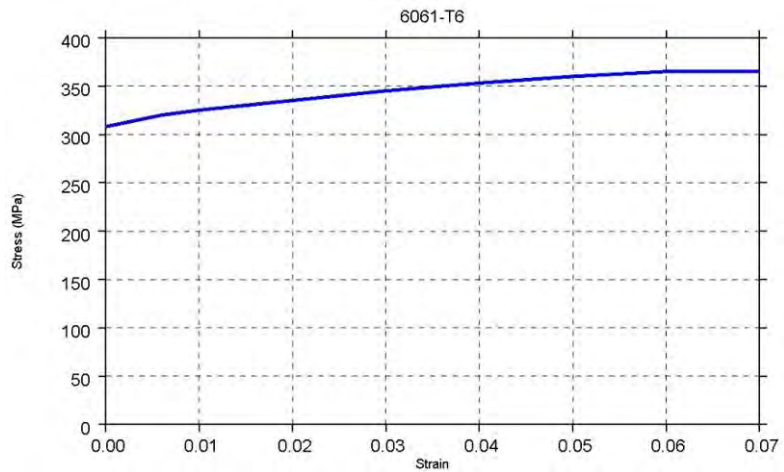

Figure 4.2.2.2.c: 6061 aluminum stress-strain curve

AL 6063-T6 (Alcoa, Ed Forsythe 10/09/27):
Young's Modulus (E) = 70,000MPa
Poisson's Ratio (ν) = 0.33
Yield Stress (σ_y) = 220MPa
Density (ρ) = $2.79e^{-9}$ tonnes/mm³

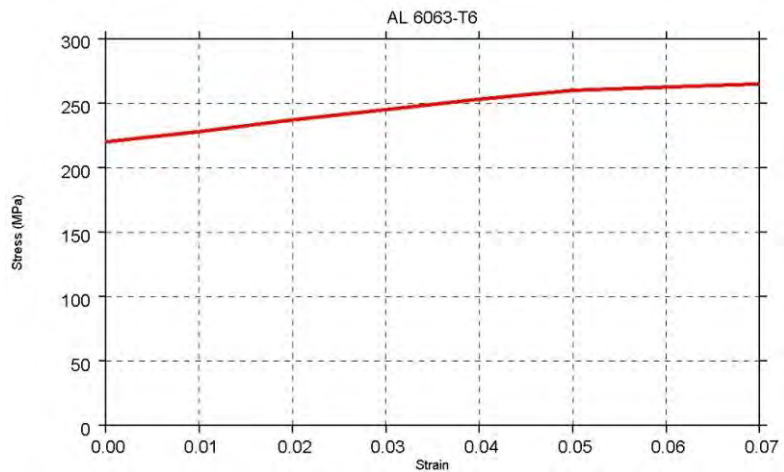

Figure 4.2.2.2.d: 6063 aluminum stress-strain curve

A356-T061 (Matweb):
Young's Modulus (E) = 72,400MPa
Poisson's Ratio (ν) = 0.33
Yield Stress (σ_y) = 179MPa
Density (ρ) = $2.79e^{-9}$ tonnes/mm³

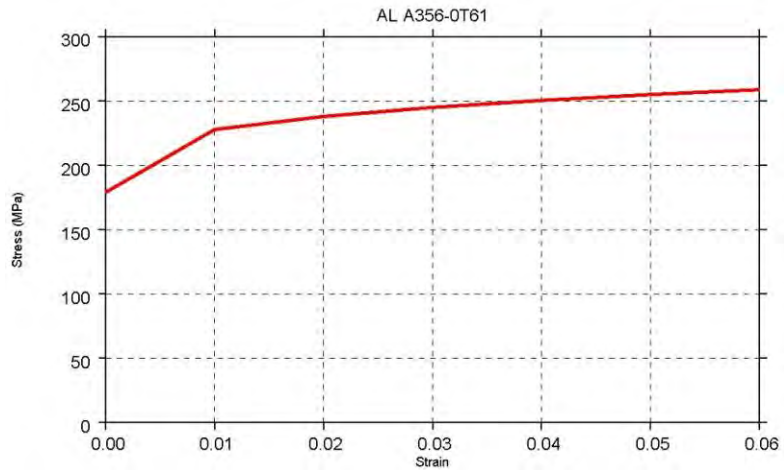

Figure 4.2.2.2.e: 6013 aluminum stress-strain curve

Heat affected zones with 'seam' welding were modeled with reduced material properties. Based on experience, a 40-percent reduction in the base material was used (i.e. for 6061-T6 a yield stress of 184.8MPa was used).

4.2.2.3. Magnesium

AM60 (Meridian Lightweight Technologies Inc.):

Young's Modulus (E) = 45000MPa

Poisson's Ratio (ν) = 0.35

Yield Stress (σ_y) = 130MPa

Density (ρ) = 1.81×10^{-9} tonnes/mm³

Major In-Plane Failure Strain = 6%

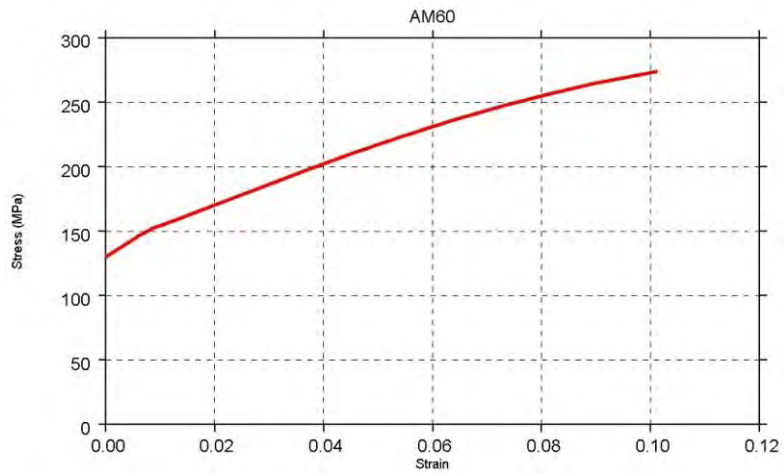

Figure 4.2.2.3.a: AM60 magnesium stress-strain curve

4.2.2.4. Composites

Nylon_45_2a (Henkel Corporation – Uhlas Grover 11/24/10)

Young's Modulus (E) = 7470MPa

Poisson's Ratio (ν) = 0.35

Yield Stress (σ_y) = 26.4MPa

Density (ρ) = $1.13e^{-9}$ tonnes/mm³

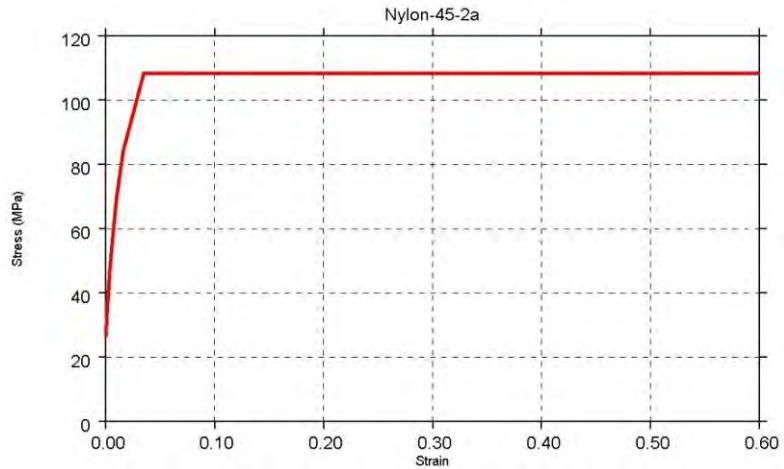

Figure 4.2.2.4.a: 45-2a nylon stress-strain curve

PET 60% glass Fill (Allied Composite Technologies – Tom Russell 11/02/10)

Young's Modulus (E) = 16,000MPa

Poisson's Ratio (ν) = 0.35

Yield Stress (σ_y) = 310MPa

Density (ρ) = $1.89e^{-9}$ tonnes/mm³

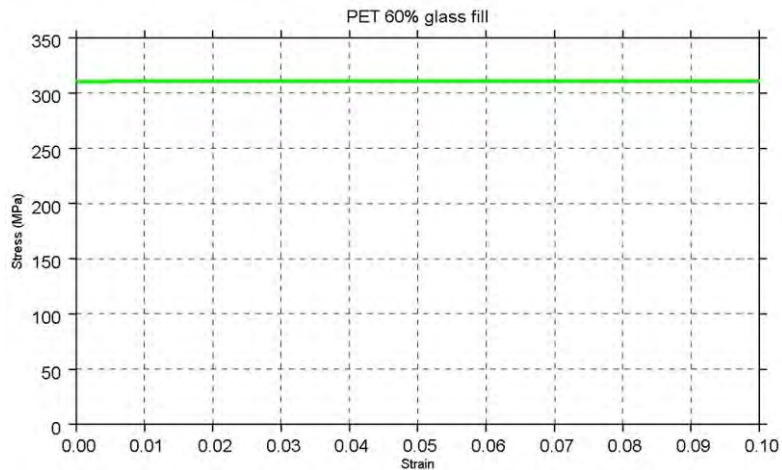

Figure 4.2.2.4.b: 60-percent glass-fiber PET stress-strain curve

4.2.2.5. Adhesives/Mastics/Composites

Terocore-1811 (Henkel Corporation – Uhlas Grover 11/24/10)

Young's Modulus (E) = 1226MPa

Poisson's Ratio (ν) = 0.194

Yield Stress (σ_y) = 18.7MPa

Density (ρ) = $4.8e^{-10}$ tonnes/mm³

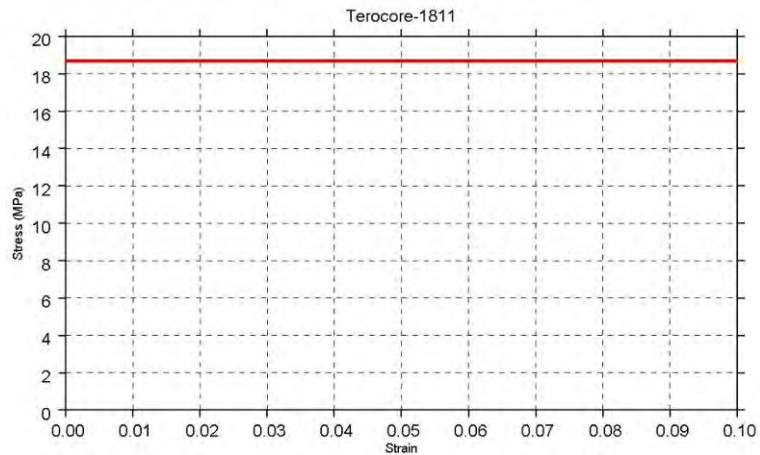

Figure 4.2.2.5.a: 1811 Terocore stress-strain curve

Terokal_5089_23c (Henkel Corporation –

tensile_test_5080_report_sr00482_10_20_08.pdf)

Young's Modulus (E) = 1649MPa

Poisson's Ratio (ν) = 0.412

Yield Stress (σ_y) = 3.434MPa

Density (ρ) = $1.14e^{-9}$ tonnes/mm³

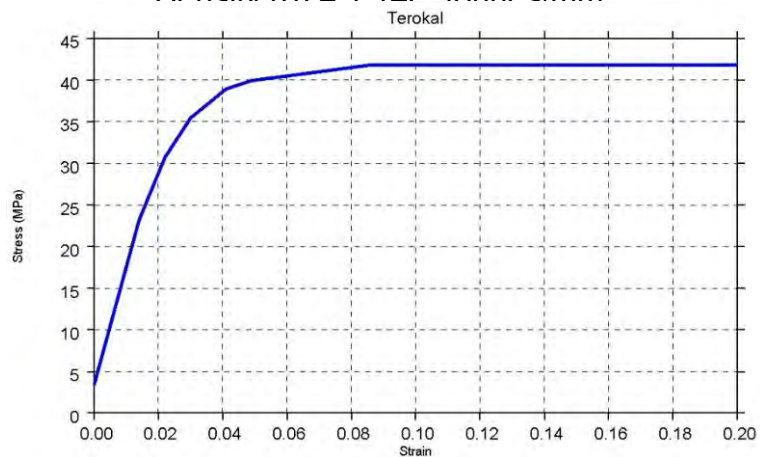

Figure 4.2.2.5.b: Terokal stress-strain curve

Note: all values shown in material curves above are true stress/true strain

4.2.3. Material Usage (location in vehicle)

The Phase 1 2020 MY Body in White make up was 30.0% magnesium, 37.0% aluminum, 6.6% steel and 21.0% composites. The remaining 5.4% consisted of paint (1.8%) and NVH material (3.6%).

The Phase 2 Body in White contains 18% less magnesium, 38% more aluminum, 1.4% more steel and 16% less composites. These changes were driven primarily by structural requirements and impact performance. Aluminum replaced magnesium as the key energy absorbing material and also replaced composites in sections of the floor structure.

Key:

Silver - Aluminum
Purple - Magnesium
Blue - Composite
Red - Steel

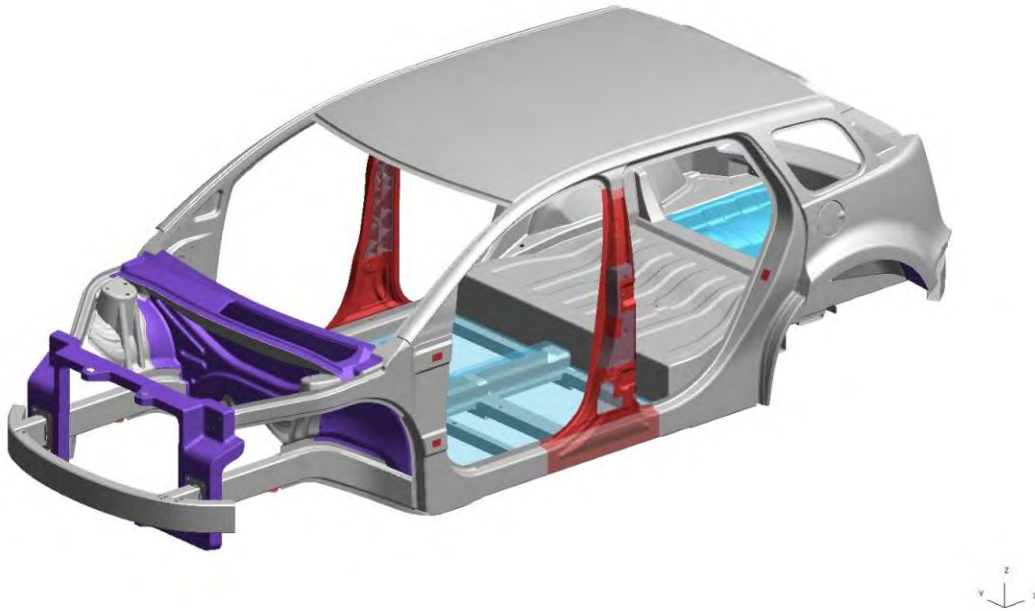

Figure 4.2.3.a: Body-in-white material usage front three-quarter view

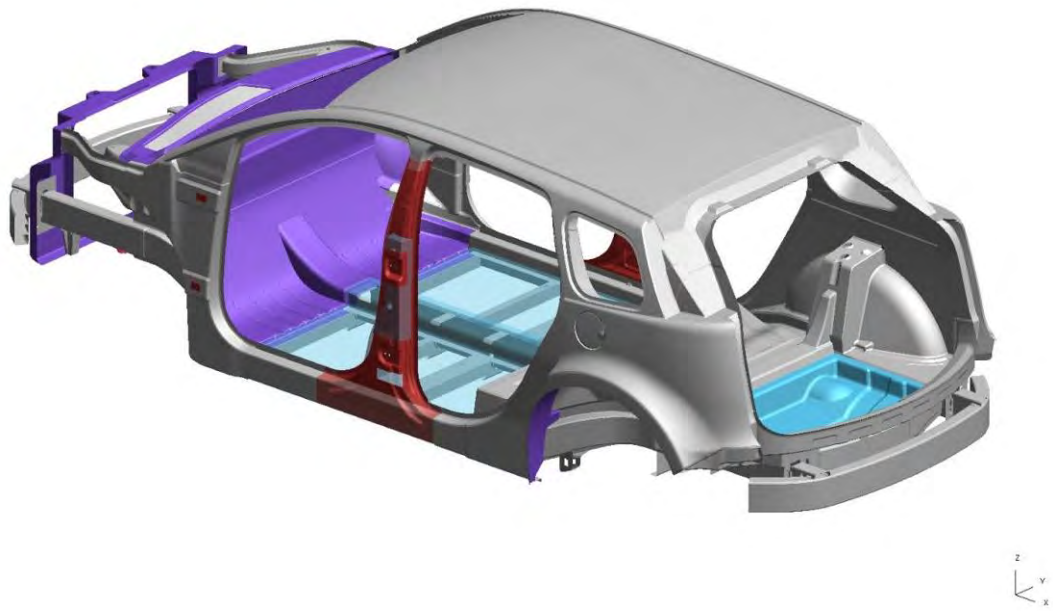

Figure 4.2.3.b: Body-in-white material usage rear three-quarter view

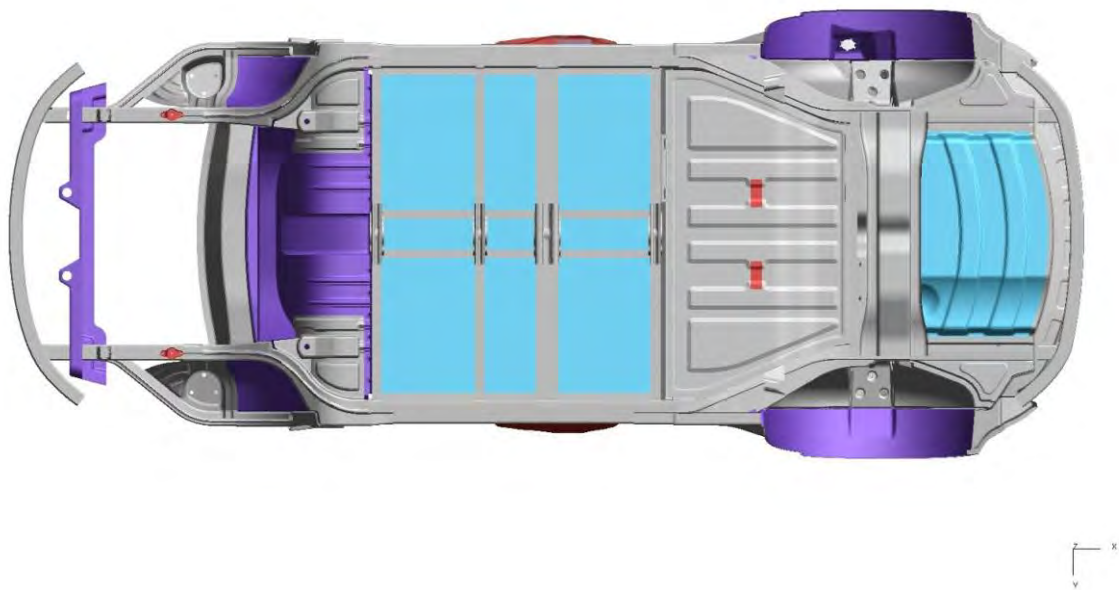

Figure 4.2.3.c: Body-in-white material usage underbody view

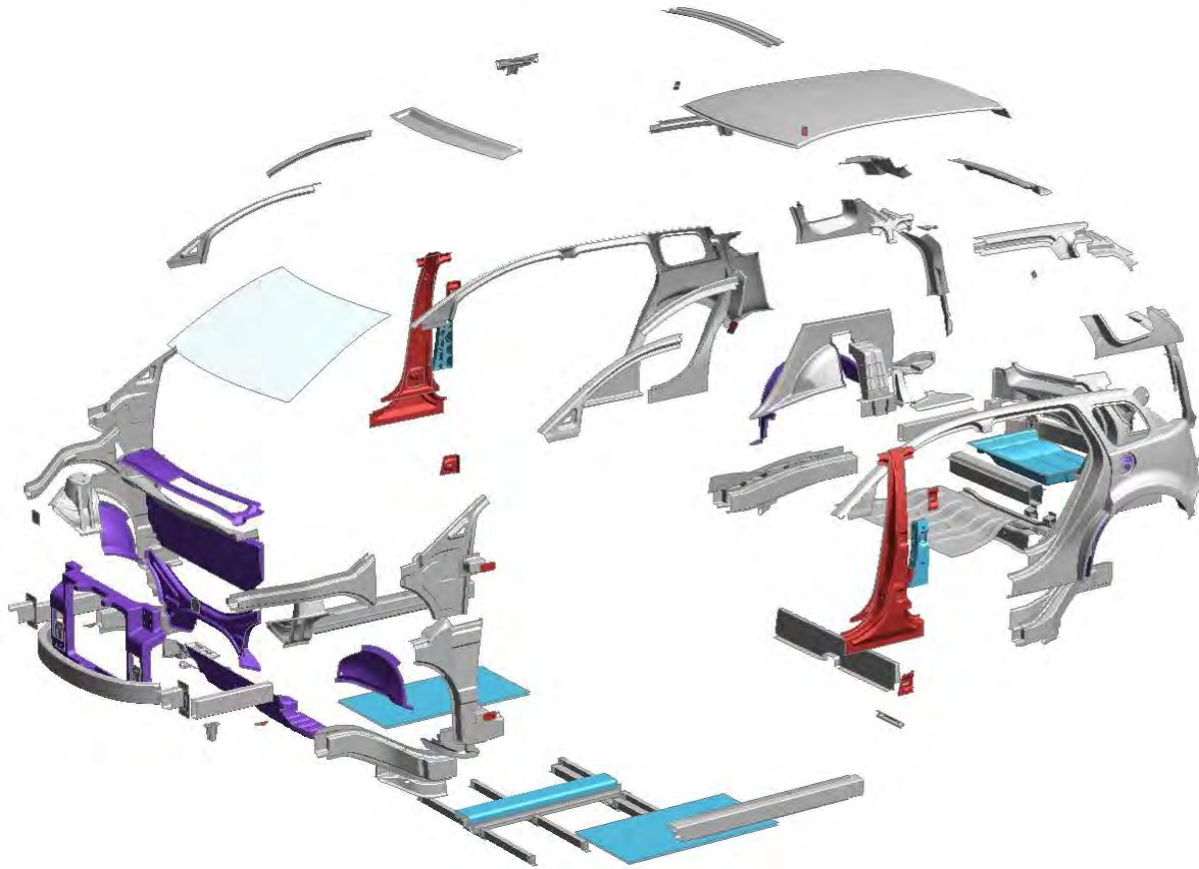

Figure 4.2.3.d: Body-in-white Material Usage Exploded View

4.2.4. Joining Methodologies

The components in the vehicle, including closures, are attached using a variety of different joining techniques including MIG welds, mechanical fasteners, friction spot joining (FSJ), rivets (including flow drill screws), and adhesives. Mechanical fasteners were used for the steel to aluminum joints and for the magnesium to aluminum joints with thin nylon washers placed between the two surfaces to prevent a galvanic reaction. Galvanic coatings were also used for the aluminum and magnesium parts. FSJs were used for the majority of the aluminum joints; Rivtec® rivets were used for single side access where it was not possible to use the FSJ process. Typical sections for these joints are shown in Figure 4.2.4.a. Structural adhesive was used to join all surfaces; 100% of the flanges and joints were adhesively bonded to maximize the structure. Friction spot joining and fasteners were used to maintain body rigidity while the adhesive cured and to prevent a peel condition during high loads, e.g., a frontal impact.

Although fatigue and corrosion modeling was beyond the scope of the study, the model incorporated Lotus best practices and supplier input from Alcoa (aluminum), Meridian (magnesium), Henkel (adhesives, galvanic coatings) and Kawasaki (friction spot joining – FSJ). This was a conservative approach that added mass, e.g., the front rails. A sensitivity analysis for the front rails demonstrated the potential to manage the front impact loads using a reduced gauge material thickness. Thinner rails were not used because of durability concerns.

Lotus has built cars using steel and aluminum joints for 18 years without fatigue/corrosion issues and this experience was applied to the model. Ford uses magnesium-steel joints that have been validated for corrosion and fatigue on the production Ford Flex (magnesium front end structure supporting the cooling module).

Jaguar and Audi use aluminum bodies on a number of current production vehicles which must meet the same corrosion and fatigue requirements as their steel bodied vehicles. Ford is also introducing an aluminum body for their 2014 F-150 pick-up body (July 27, 2012, 12:01 AM Wall Street Journal Blog and confirmed by reliable sources) which must meet Ford's internal truck standards for durability.

There are no welded Al-Mg or Al-Fe joints; there were no processes that could demonstrate this capability in the time frame of this study. These joints are joined with structural adhesive and mechanical fasteners on the Phase 2 BIW. There are a number of technologies under development that have commercialization potential for joining dissimilar materials, e.g., electromagnetic pulse forming (Ohio State University, Dr. Glenn Daehn, Director, Ohio Manufacturing Institute).

The B-Pillar construction consists of hot stamped boron steel inner and outer panels spot-welded at the flanges; a nylon structural insert is bonded to the B-Pillar outer using Terocore 1811 (no mechanical fasteners used).

For the non-ferrous 'point' connection entities, a nominal pitch of 75 mm was used. In areas with higher loads the pitch was reduced to ~50 mm.

Material samples were provided by Alcoa, Allied Composite Technologies, Meridian, and Henkel. Material treatments and joining methodologies based on materials interfaces are as follows:

Friction spot joining (FSJ) was used to join the majority of the aluminum components. FSJ was developed by Kawasaki Heavy Industries. A cylindrical joining tool, with a small projection at the tip, known as the pin (pin tool), rotates while plunging and then withdrawing from the material creating a metallurgical bond. The rotation of the tool first softens the material by means of frictional heat creating a plastic flow effect in the rotary and axial directions in the periphery of the pin, thereby stirring and joining the upper and lower plates. The whole process is completed within a matter of seconds. The material then maintains a solid state without any melting.

- Friction stir welding uses a small electric motor and a unique drill bit to engage two sheets of aluminum and flow the material in the plastic region; key advantages are cost (1/20th of a resistance spot weld per http://www.khi.co.jp/english/robot/product/files/webrobot/upload_pdf/catalog_e_fsj.pdf), weight (vs. rivets and fasteners) and no degradation of the parent material properties (vs. welding).
- Aluminum-magnesium joints were secured using mechanical fasteners
- Magnesium samples were treated with Henkel's Alodine coating for galvanic isolation
- Aluminum coupons were anodized
- Magnesium coupons were pretreated with Alodine – a production requirement to prevent a galvanic reaction with the aluminum (used by Ford on the Flex front structure)

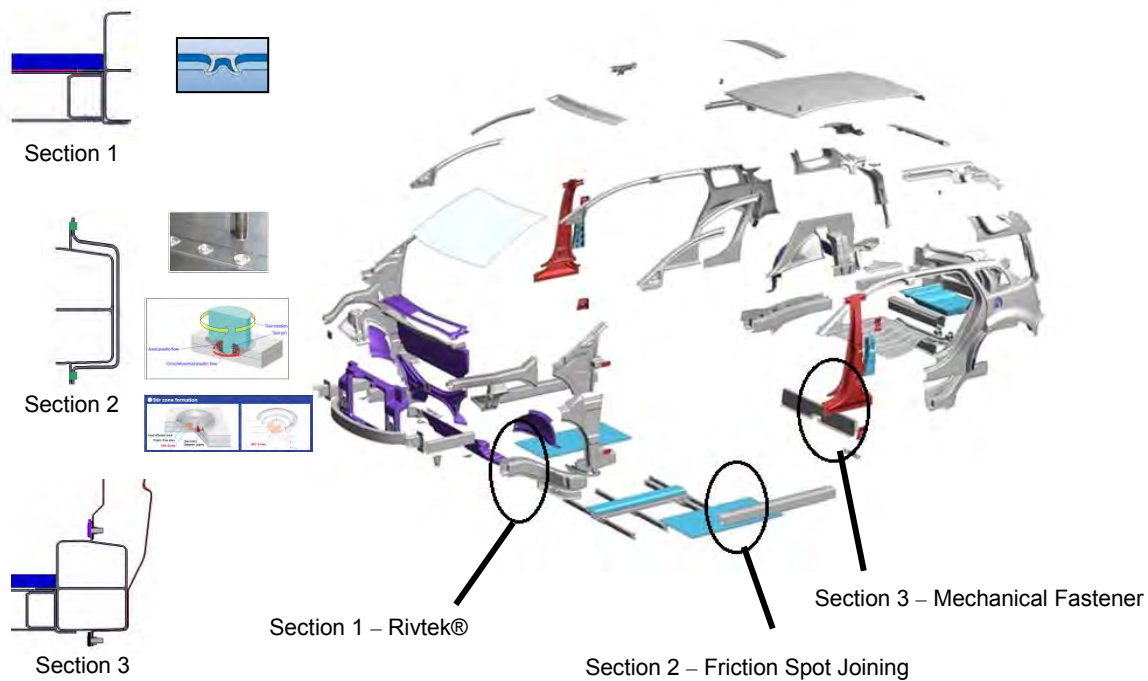

Figure 4.2.4.a: Typical Joint Sections

Material lap-shear tests were carried out by Henkel & Kawasaki to empirically determine the properties for the joints. Results are shown in Figure 4.2.4.b.

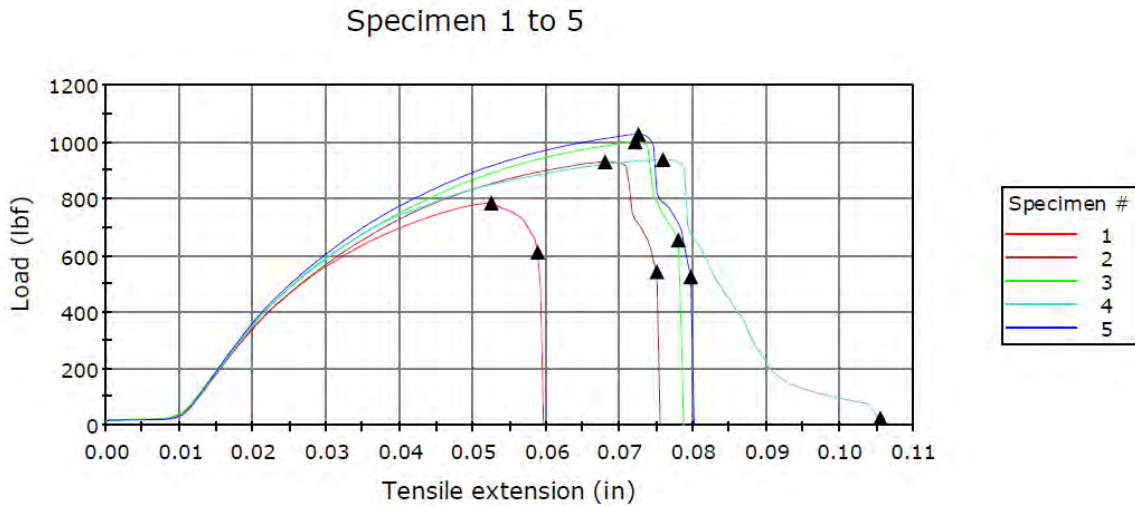

Figure 4.2.4.b: Henkel & Kawasaki lap-shear tests

A CAE model was created to correlate the values from the lab testing to those used in the CAE model based on an average test value. A shear failure force of 3860 N was used for the LS-DYNA® *MAT_SPOTWELD modeling.

Joints using mechanical fasteners were modeled using 5 mm diameter bolts with a minimum shear failure force of 10,000 N. This force equates to a minimum shear stress of ~500 MPa.

Henkel supplied the Terokal 5089 adhesive and the material properties. Lap-shear tests on the Terokal only joints were carried out by Henkel. The results showed that the bond joint fails and not the adhesive, and as such, the model assumes there is no failure of the adhesive bond. r

The following summarizes the tests that were carried out:

Terokal Only Lap Shear Test

Bondline: 0.25 mm, Bake: 10 min Metal Temp @ 155°C, Pull Speed: 10 mm/min, Treatment: AM60B treated with Alodine

- AL6061 to AL6061: Lap Shear – 35.8 MPa
- AL6061 to AM60B: Lap Shear – 29.5 MPa
- AL6061 to AL6061: Lap Shear – 20.5 MPa

The aluminum joint failures listed above are of a peel type, which results in a partial adhesive failure at the edge of the joint. A similar peel-type failure was seen in the magnesium joints. Here however, the adhesive removed the Alodine pretreatment, causing the failure.

4.2.5. Model Mass/Other Information

The total model initial weight was adjusted to the target curb weight of 1150 kg. This mass is based on the Phase 2 body mass and the Phase 1 High Development masses in *An Assessment of Mass Reduction Opportunities for a 2017 – 2020 Model Year Vehicle Program* published in March 2010².

The non-body system masses for the Phase 1 study, along with the baseline system masses, are shown below in Table 4.2.5.a.

Table 4.2.5.a: Phase 1 High Development System Masses

| System | Venza Baseline Mass (kg) | Phase 1 HD Mass (kg) |
|--------------------|--------------------------|----------------------|
| Closures/Fenders | 143.02 | 83.98 |
| Bumpers | 17.95 | 15.95 |
| Thermal | 9.25 | 9.25 |
| Electrical | 23.6 | 15.01 |
| Interior | 250.6 | 153 |
| Lighting | 9.9 | 9.9 |
| Suspension/Chassis | 378.9 | 217 |
| Glazing | 43.71 | 43.71 |
| Miscellaneous | 30.1 | 22.9 |
| Powertrain | 410.16 | 356.2 |
| Totals | 1317.19 | 926.90 |

The vehicle curb weight was calculated using the above masses and the Phase 2 body mass. The weight distribution was set at 55/45 front/rear percentage.

The fuel tank was modeled as an airbag at 90-percent full so that any change in pressure could be extracted and reviewed to determine if there was an instantaneous pressure change that could affect fuel retention.

The ground plane was set at 238.767z.

NHTSA has carried out crash tests on the baseline vehicle, a 2009 Toyota Venza. These test results can be found on the NHSTA website (<http://www-nrd.nhtsa.dot.gov/database/veh/veh.htm>). The front impact test report (35mph flat frontal) used to compare the simulation results can be accessed from the following link ([57](http://www-</p>
</div>
<div data-bbox=)

nrd.nhtsa.dot.gov/database/aspx/searchmedia2.aspx?database=v&tstno=6601&mediatype=r&r_tstno=6601).

Results from IIHS testing can be found on the following website (www.iihs.org).

4.2.5 CAE Test Set-Up

4.2.5.1. FMVSS 208: 35 mph Front Impact (0°/30° rigid wall, offset deformable barrier)

The FMVSS 208 35-mph load case involves an impact against a perpendicular rigid wall. The vehicle model was analyzed with its curb weight, two frontal occupants, luggage and fuel. The figure below shows the vehicle in top, front, side, and isometric views.

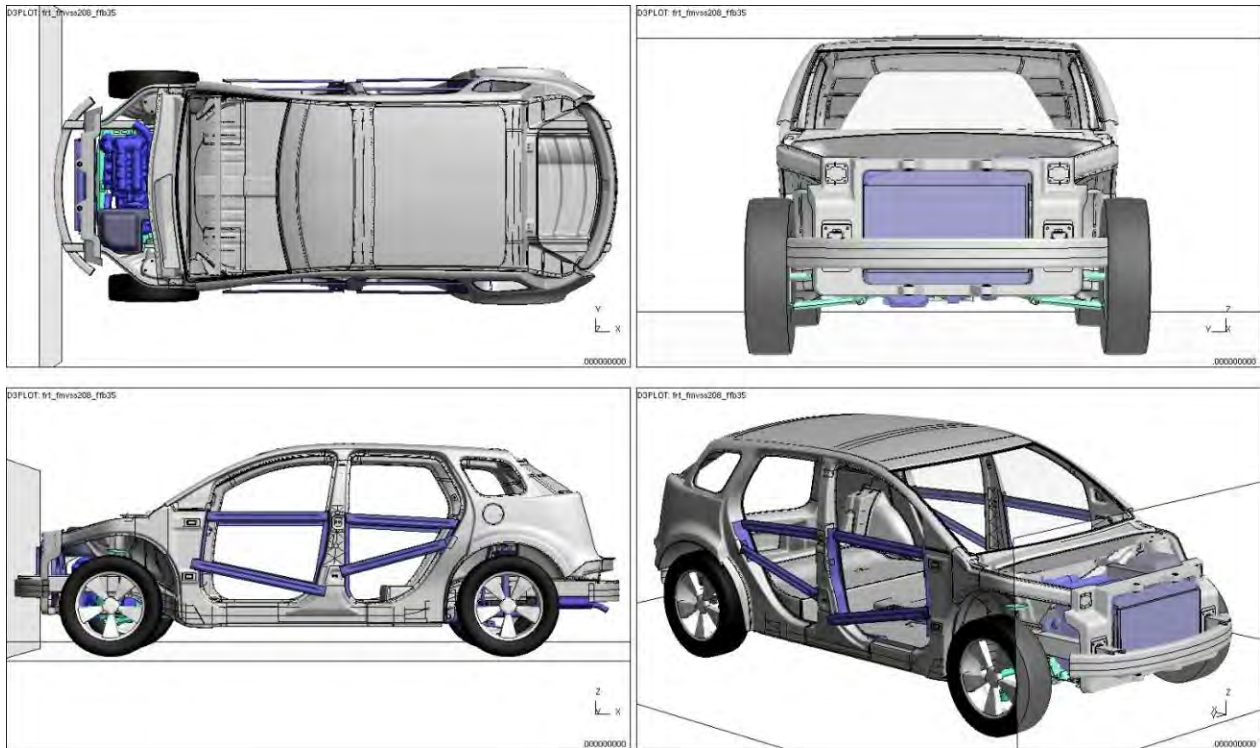

Figure 4.2.5.1.a: Rigid, deformable wall crash-test model setup

4.2.5.2. FMVSS 208: 25 mph Offset Deformable Barrier

The FMVSS 208 25-mph load case involves an impact into a deformable barrier that overlaps the vehicle by 40 percent. The vehicle model was analyzed with its curb weight, two frontal occupants, luggage and fuel. The figure below shows the vehicle in top, front, side, and isometric views.

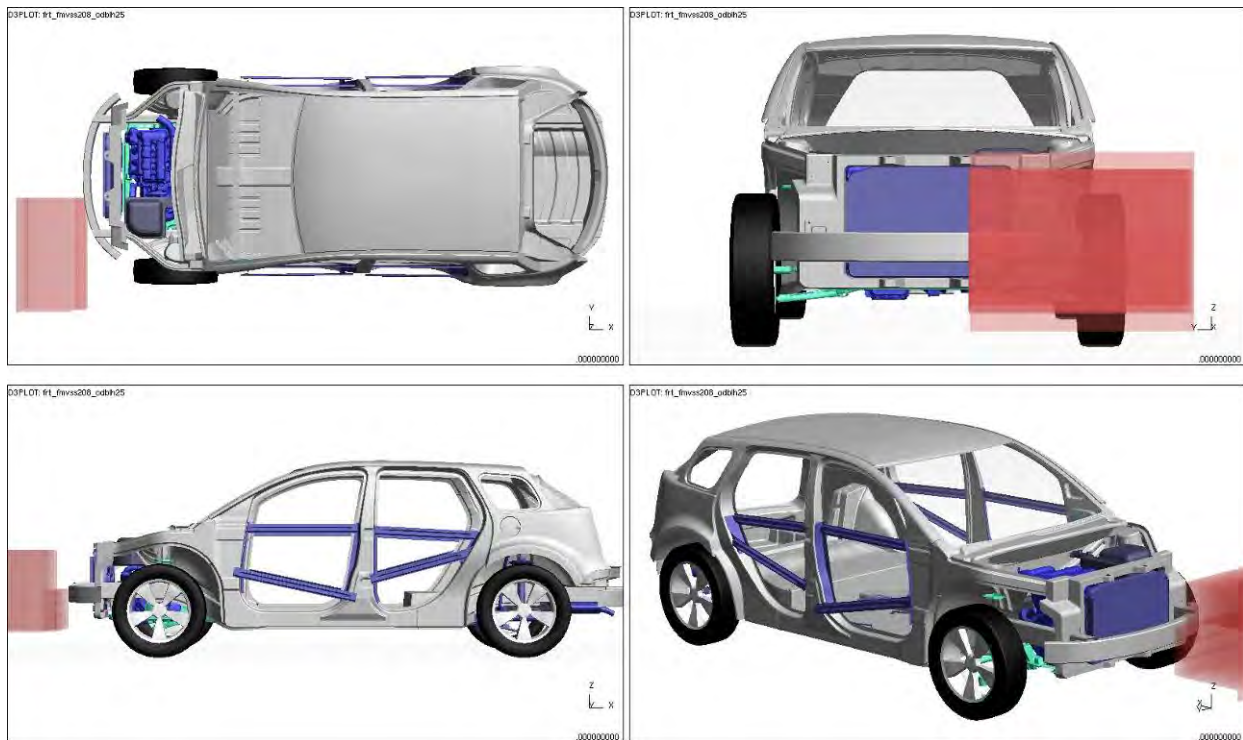

Figure 4.2.5.2a: 40-percent barrier overlap crash-test model setup

4.2.5.3. FMVSS208: 25 mph 30° Flat Barrier – Left Side

The FMVSS 208 25-mph, 30-degree flat rigid wall barrier load case is carried out to ensure the occupants stay within the bounds of the vehicle during the crash event. As no closures or occupants were included in the models this could not be assessed. The structure will be evaluated to ensure that there would be minimal (if any) deformation of the door aperture that would cause the occupant to be ejected.

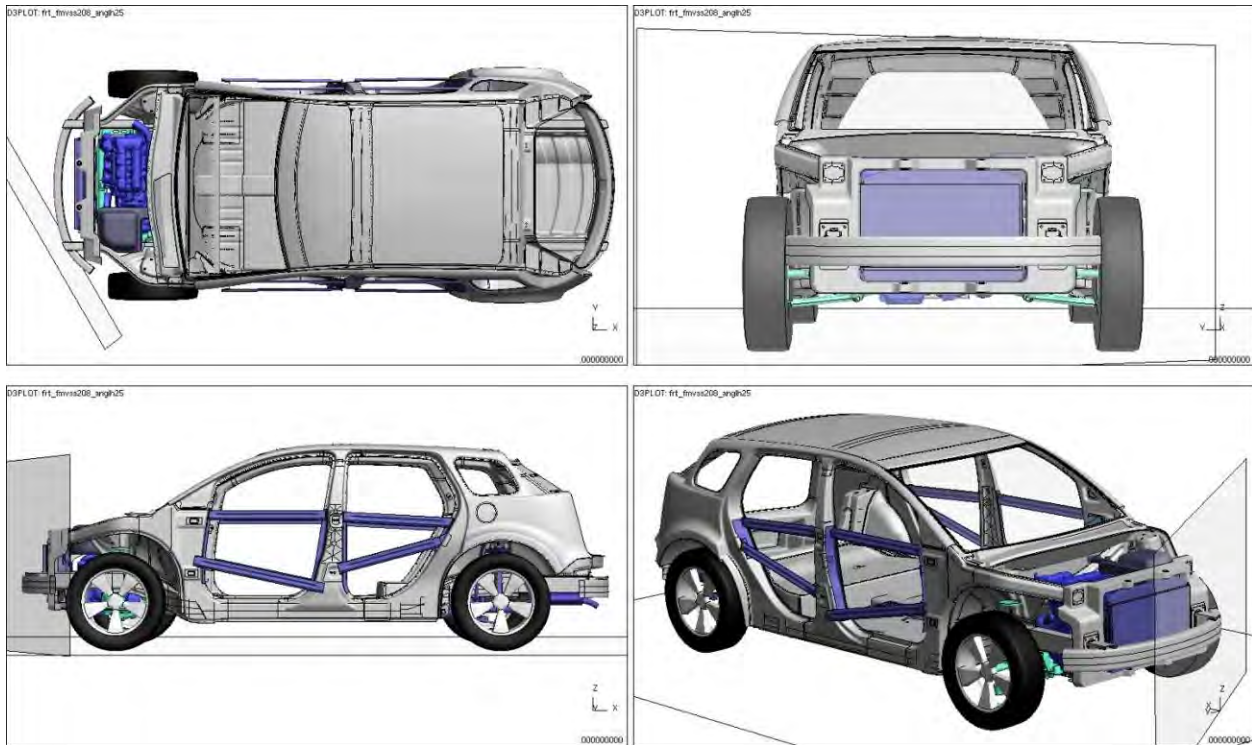

Figure 4.2.5.3.a: 30°, left-side barrier crash-test model setup

4.2.5.4. FMVSS208: 25 mph 30° Flat Barrier – Right Side

The FMVSS 208 25-mph, 30-degree flat rigid wall barrier load case is carried out on both the left and right hand sides of the vehicle. This would be performed to ensure equal protection of both the driver and passenger.

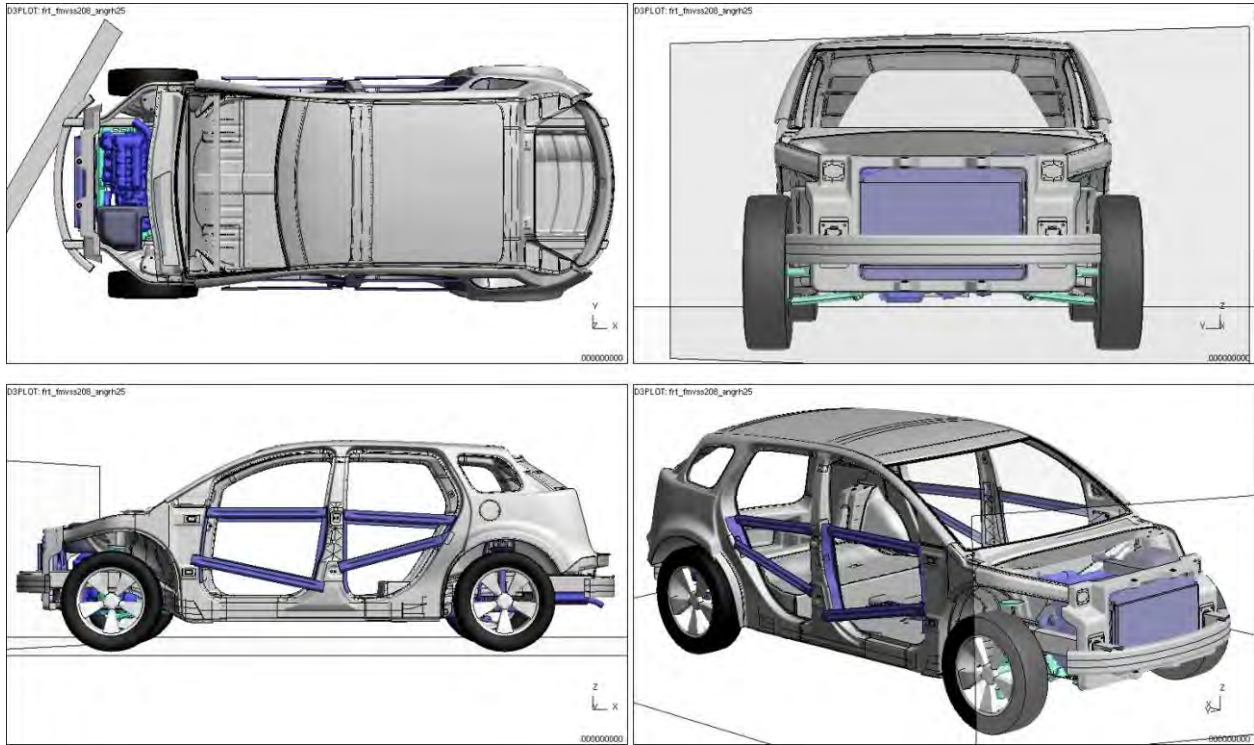

Figure 4.2.5.4.a: 30°, right-side barrier crash-test model setup

4.2.5.5. FMVSS 210: Seatbelt Anchorages

Front

The FMVSS 210 seatbelt anchorage requirement ensures the seats, seatbelts, and corresponding anchorage points are strong enough to handle the test load. Load is applied to two loading devices called body blocks (shoulder and lap) which transfers load to the structure by the seatbelts. This test is performed at all seating locations.

It was assumed that the Phase 2 vehicle lower seatbelt was attached to the seat structure, so the lap block load would be transmitted into the four seat mounts. The Phase 2 model does not include any seating systems so these loads were applied to the rear seat mounts, applying higher loads to these locations.

The lower body block's movement is constrained such that it can only move in the direction of the applied load (10° above horizontal), as there was no seat included in the model.

The load applied to the upper and lower body blocks is 17,125 N (3500 lbs +10 percent). This load is applied over 0.15 s and held constant for 50 ms.

As both the left and right side of the vehicle structure are symmetrical, this analysis was only performed on the right hand front occupant location.

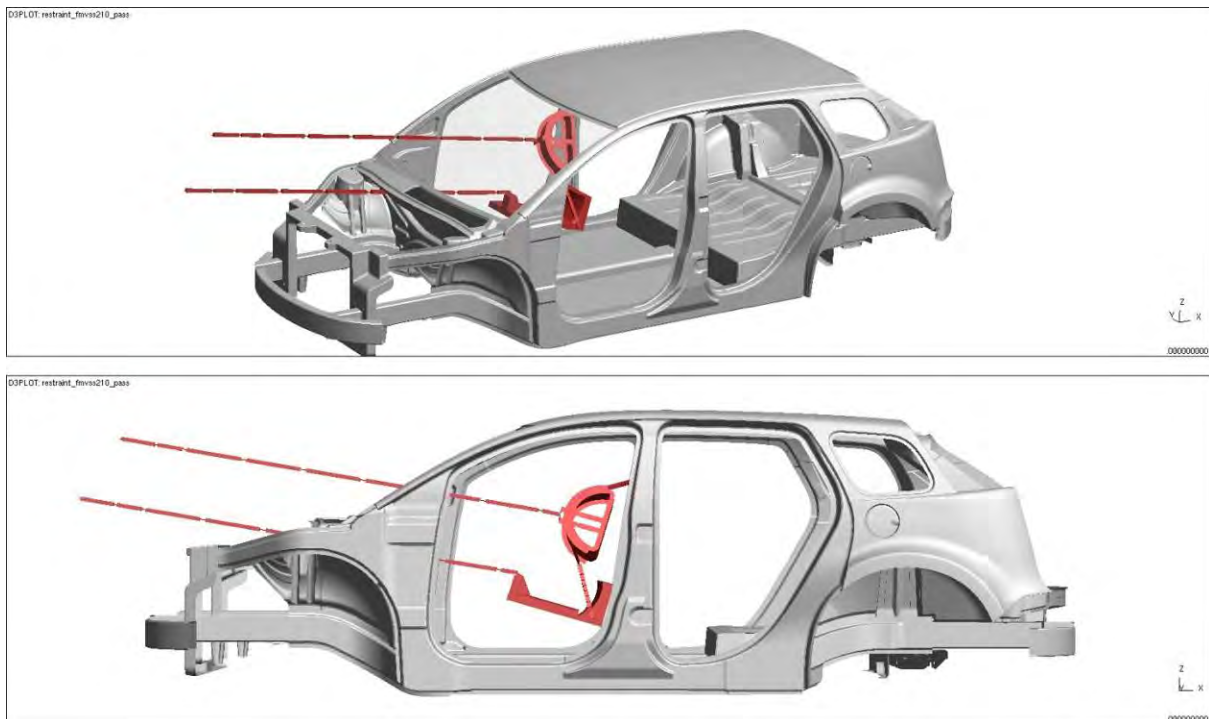

Figure 4.2.5.5.a: Front seatbelt anchorage test model setup

Rear

The test load was applied simultaneously at all rear-seat locations.

The lower body block's movement is constrained in the model such that it can only move in the direction of the applied load (10° above horizontal).

The load applied to both the left and right, upper and lower body blocks is 17,125 N (3500 lbs +10 percent). This load is applied over 0.15 s and held constant for 50 ms.

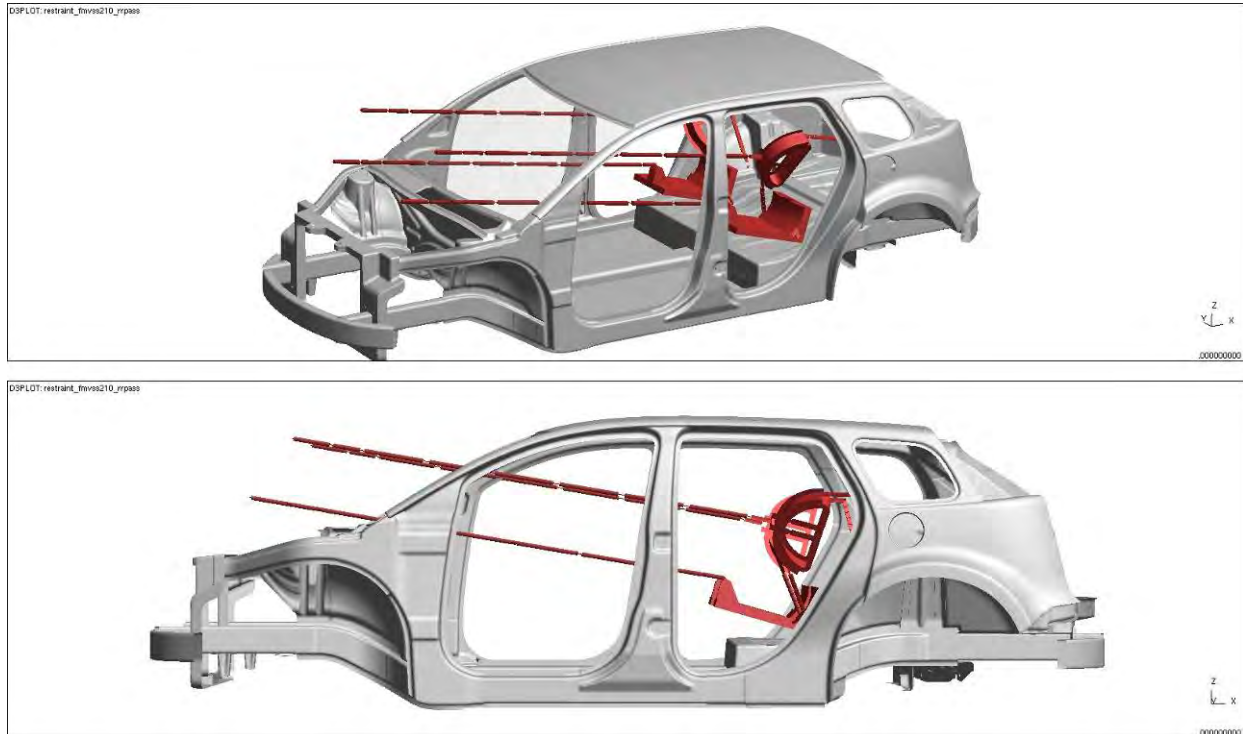

Figure 4.2.5.5.b: Rear seatbelt anchorage test model setup

4.2.5.6. FMVSS 213: Child Restraint Systems

The FMVSS 213 child restraint anchorage requires that these systems are such that they will restrain a child occupant when subjected to a crash impact.

The restraint mounting location was tested under conditions greater than the required load case in order to evaluate any potential structural problems.

A child dummy was represented using a beam element with the mass set to 30 kg, which is nearly 50-percent heavier than the heaviest necessary test dummy to account for unknowns at this early stage of vehicle development. This was attached to the body structure at four locations (retractor, D-ring, buckle, and fixed end) using seatbelt

elements. Actual requirements specify a number of the child Hybrid III test dummies, the heaviest being the 10-year old (which weighs 21 kg). The testing was performed using the heaviest weight to create a worst-case loading.

The test specifies that an acceleration pulse, representative of a vehicle pulse, be applied; the pulse is shown in the graph below.

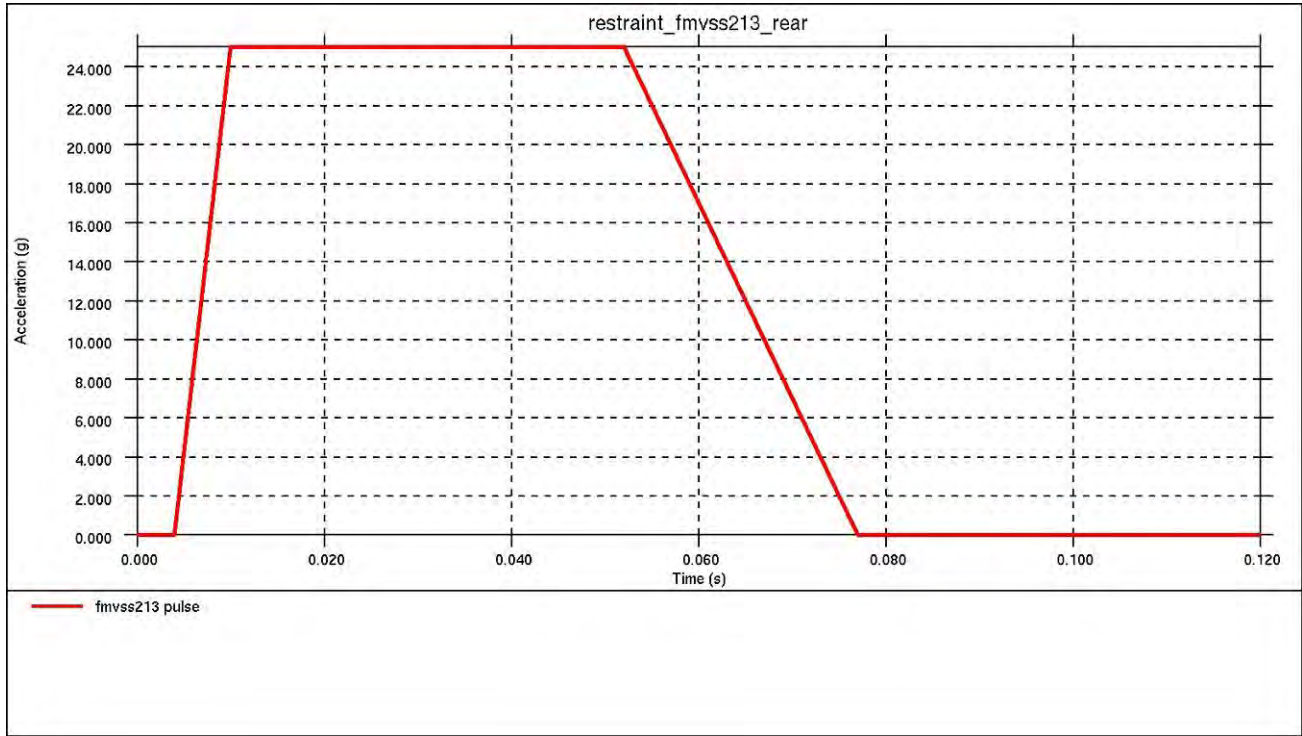

Figure 4.2.5.6.a: Acceleration pulse applied to child-restraint model

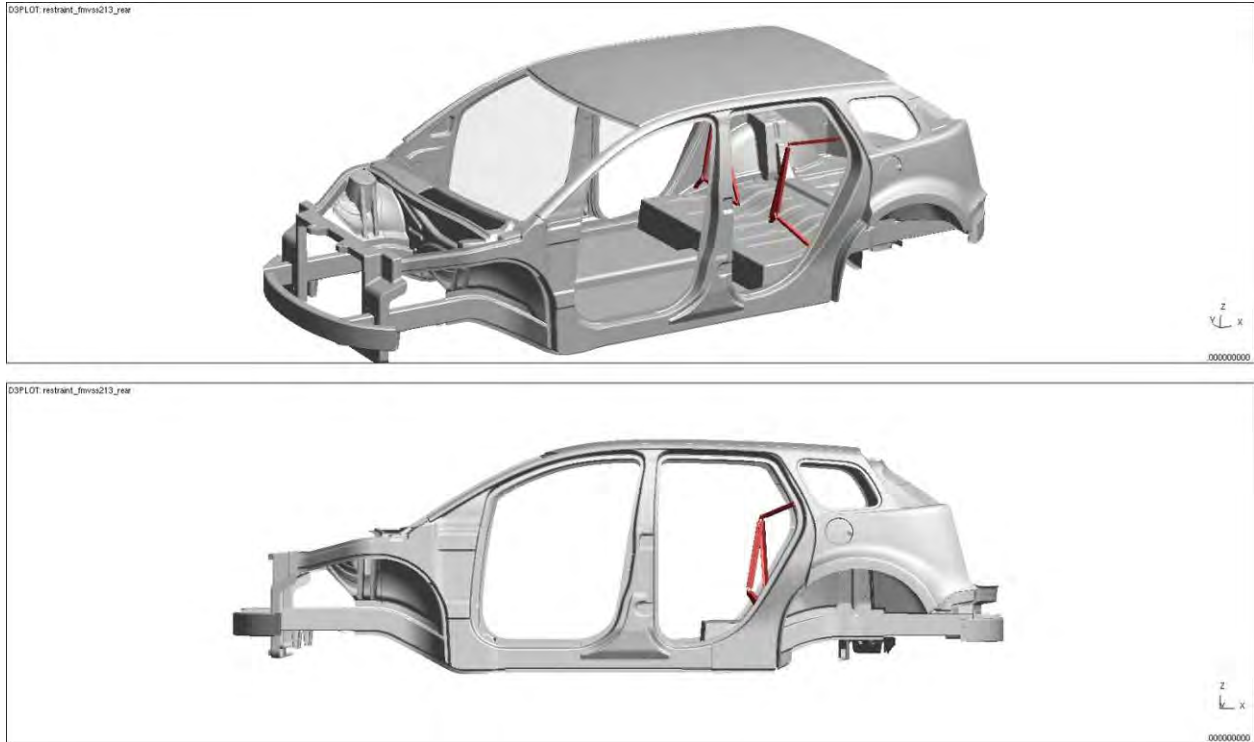

Figure 4.2.5.6.b: Child-restraint test model setup

4.2.5.7. FMVSS 214: 33.5 mph Side Impact – Crabbed Barrier

The FMVSS 214 33.5-mph, 27-degree moving deformable barrier load case is carried out on both the left and right hand sides of the vehicle. This test monitors the severity of the injuries sustained by the occupants seated at the front and rear, outboard seating locations. This test is carried out on a complete vehicle with closures, dummies, interior, and occupant restraining systems. Since engineering those components was beyond the scope of this portion of the project, the B-Pillar intrusion velocity and displacement were monitored on the CAE model. The maximum allowable intrusion level was defined as 300 mm – a typical distance to the closest outboard portion of the seat.

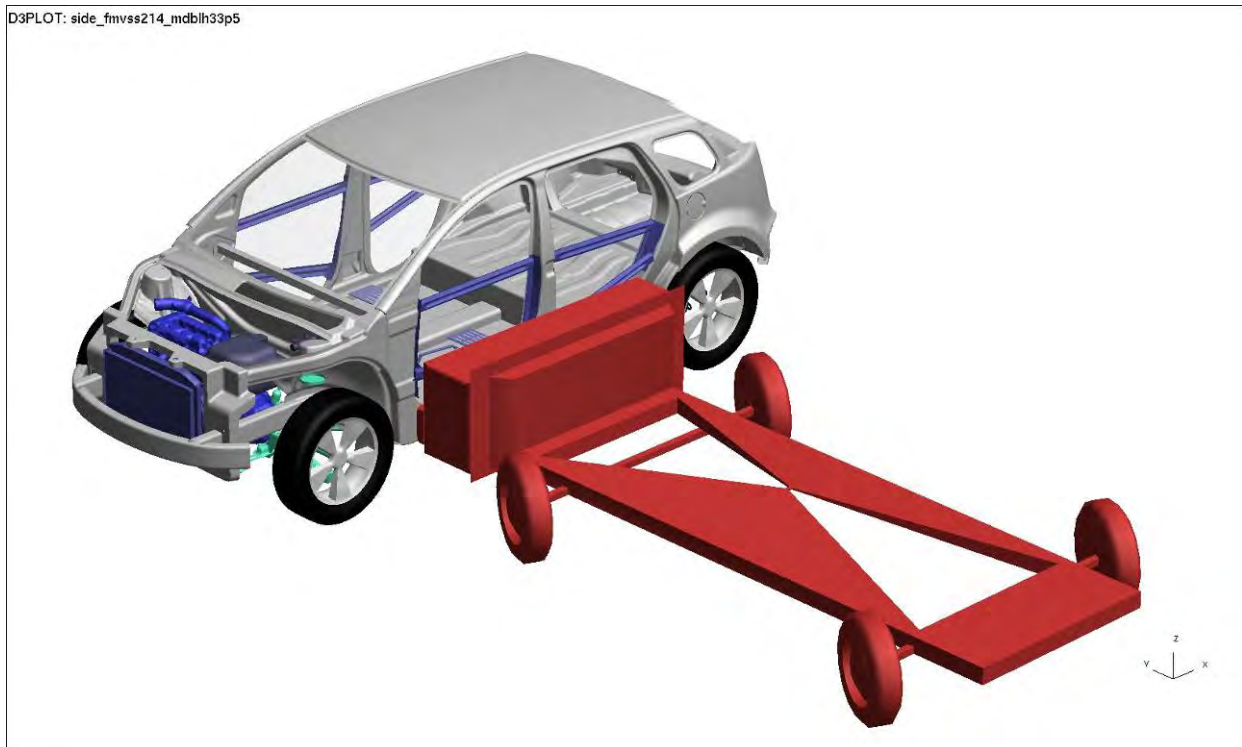

Figure 4.2.5.7.a: Crabbed barrier test model setup

4.2.5.8. FMVSS 214: 20 mph 75° Side Pole Impact – Front (5th percentile Female)

The FMVSS 214 20-mph, 75-degree, pole-load case is carried out with a rigid pole lined up with the occupant head CG location along the direction of travel. It is carried out with a 5th-percentile female dummy and a 50th-percentile male dummy. This puts the seat in two different locations so the initial impact points are different.

The test requires monitoring injuries sustained by the occupants and would be carried out on a full vehicle with closures, dummies, interior, and an occupant restraining system. As noted above, this was beyond the project scope. The B-Pillar intrusion velocity and displacement were again measured on the CAE model.

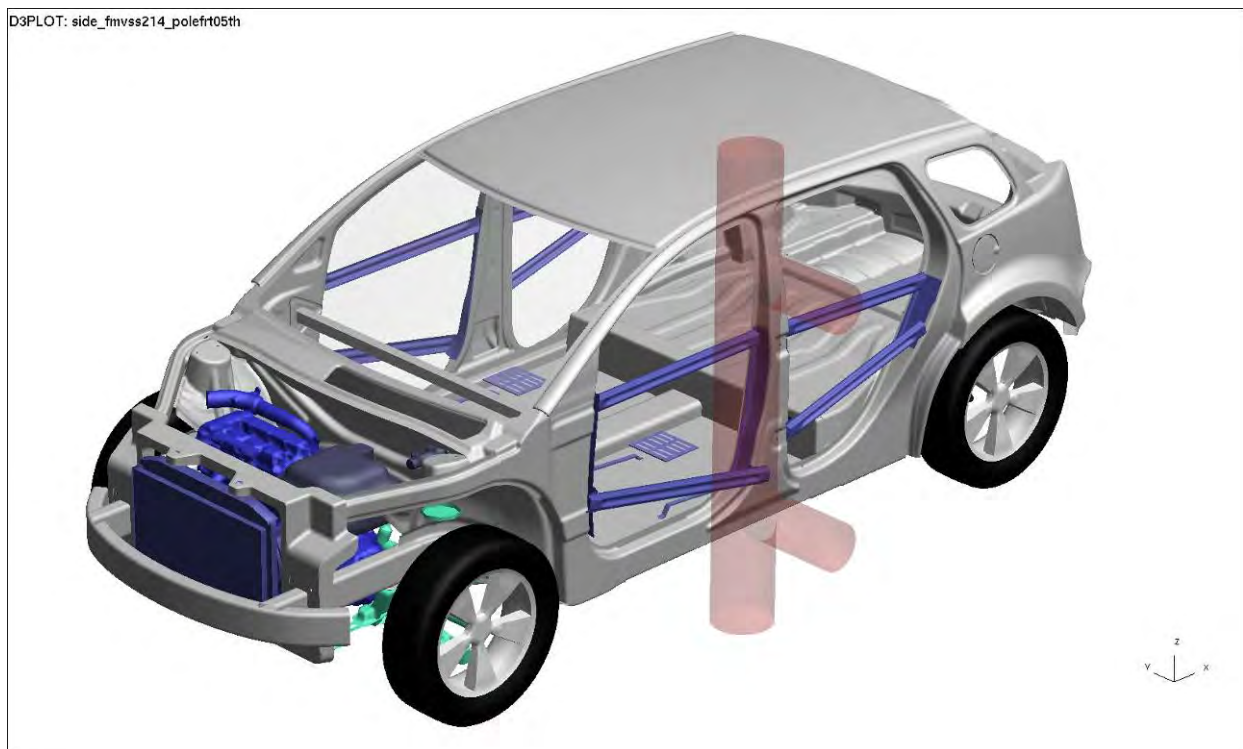

Figure 4.2.5.8.a: Side-pole impact test model setup

4.2.5.9. FMVSS 214: 20 mph 75° Side Pole Impact – Front (50th percentile Male)

The FMVSS 214 20-mph, 75-degree, pole-load case for the male seating position put the initial pole contact point further rearwards in the vehicle than for the 5th-percentile female but still forward of the B pillar.

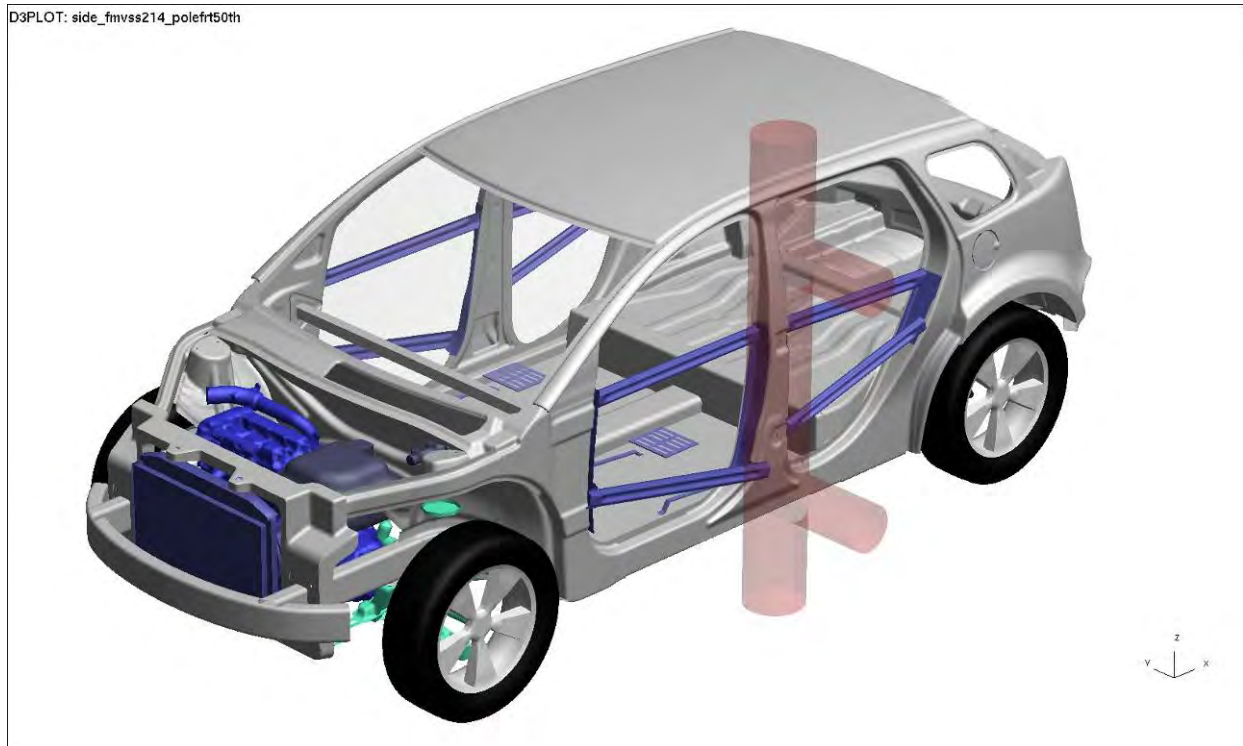

Figure 4.2.5.9.a: Side-pole impact test model setup

4.2.5.10. FMVSS 216: Roof Crush

The FMVSS 216a roof-crush load case evaluates vehicle performance in a ‘roll-over’ crash scenario. The actual test is carried out quasi-statically to represent a load being applied to the upper A-pillar joint. The regulation specifies that the vehicle be able to withstand 3 times its curb weight without loading the head of a Hybrid III 50th-percentile male occupant with more than 222 N (50 lbs).

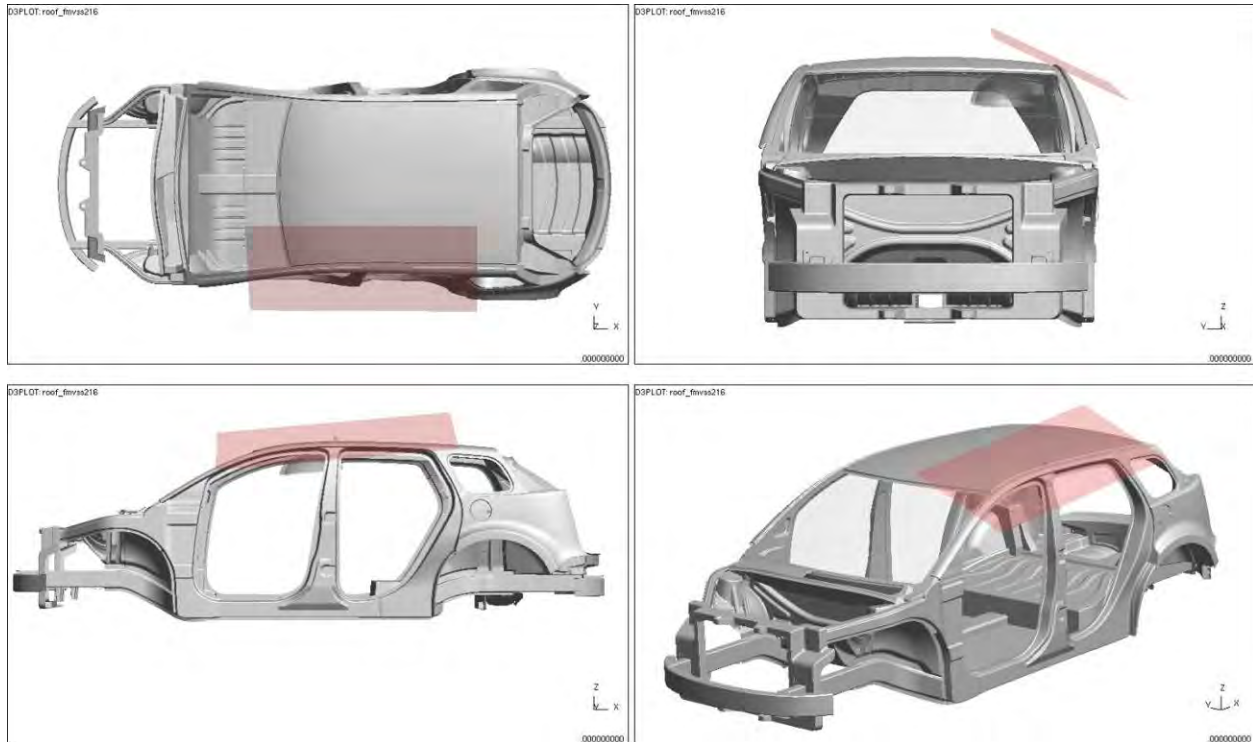

Figure 4.2.5.10.a: Roof crush test model setup

4.2.5.11. FMVSS 301: Rear Impact (moving deformable barrier)

The FMVSS 301 50-mph, 70-percent overlap rear moving deformable barrier load case primary function is to check the vehicle fuel system integrity to reduce potential vehicle fires caused by post-impact fuel spillage.

The CAE model incorporated a fuel tank, filler neck, and battery pack. Lotus evaluated the fuel tank/filler and battery pack to assess potential problems that could occur as a result of deformation in this area. The design objective was to create an environment that prevented any part of the body from contacting either the fuel tank or the battery pack.

The test was carried out on both the left and right sides of the vehicle. Only results for the left side are shown as this is where the fuel tank and fuel filler are located.

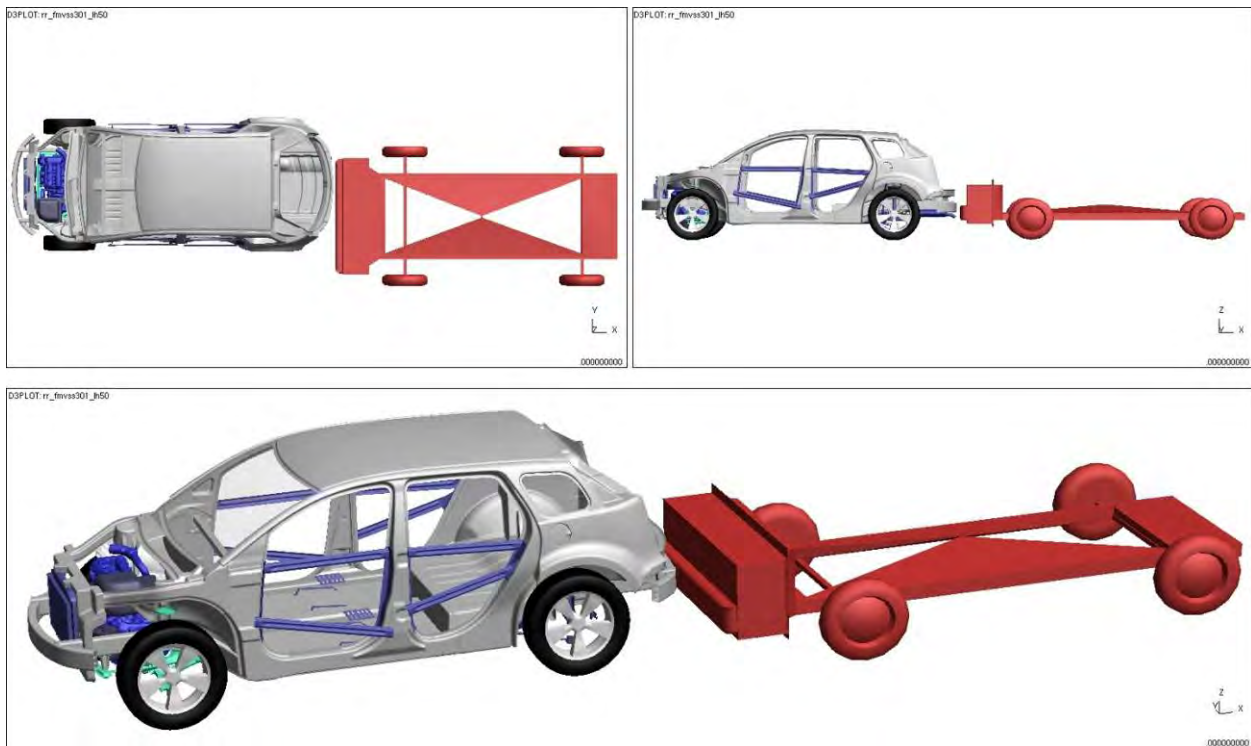

Figure 4.2.5.11.a: Deformable, moving barrier rear impact test model setup

4.2.5.12. IIHS Low Speed – Front

The low-speed IIHS requirement evaluates vehicle performance at impact speeds of 10 kph and 5 kph in full and offset impacts. This test has been derived by the IIHS to establish the amount of damage and subsequent repair costs.

Impacts are into a contoured deformable barrier set to specific heights depending upon the impact being carried out (barrier lower edge 457 mm from ground in ‘full’ impacts and 406 mm from ground in offset impacts). The offset impacts are carried out with a 15-percent overlap of the barrier to the vehicle.

A full evaluation of the damage was not carried out as the CAE body model does not include the fascia, hood, fenders, lights, grille, etc. The performance assessment was made based on the extent of permanent deformation (plastic strain) predicted in the structure. The vehicle curb weight was used with an additional 77.1-kg ballast at the driver’s seat.

The front and rear suspension models were replaced with simplified representations with springs for the vertical (tire/spring) and lateral (tire friction) directions. Values for the vertical spring were calculated from the suspension spring rates and the unloaded to loaded tire radius; the lateral rate was calculated from an estimated tire contact area and friction.

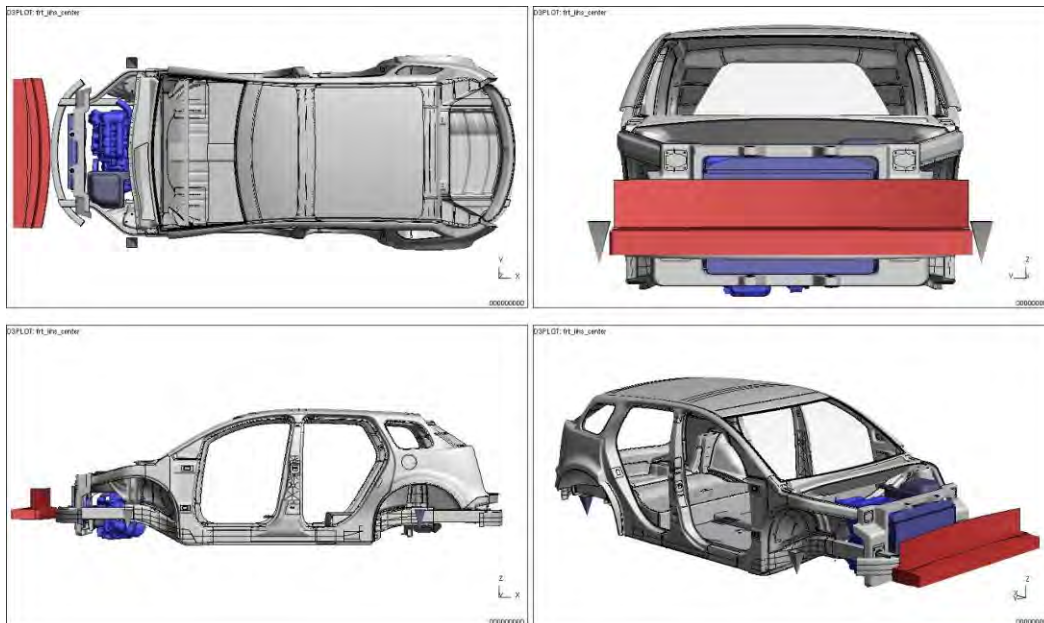

Figure 4.2.5.12.a: IIHS, low-speed, front test model setup ('full impact')

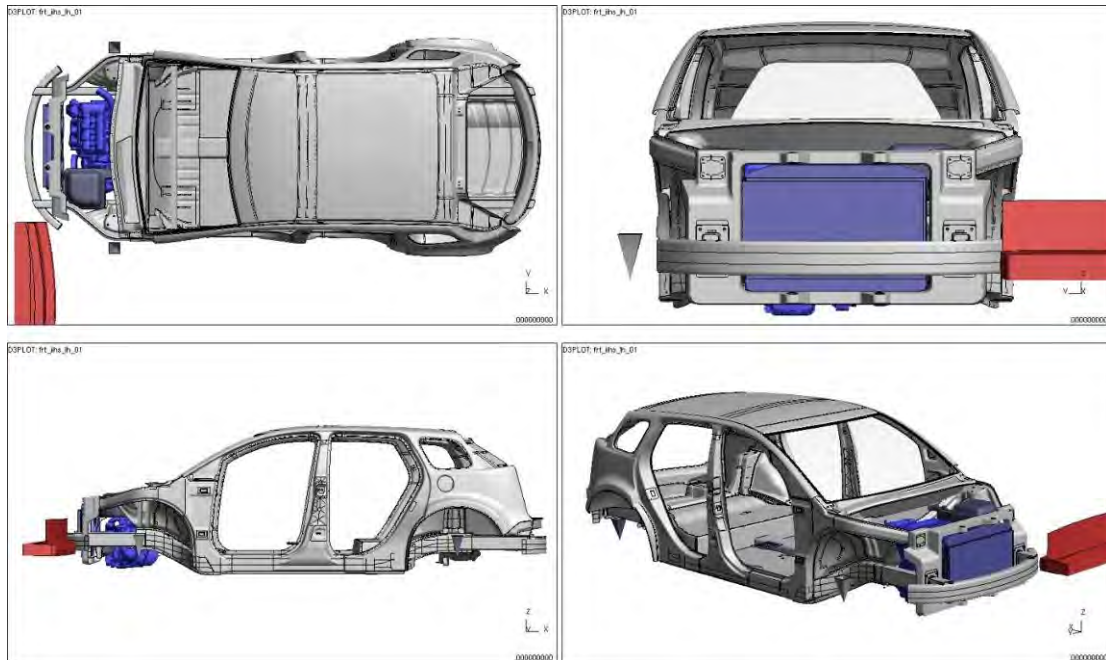

Figure 4.2.5.12.b: IIHS, low-speed front test model setup ('offset impact')

4.2.5.13. IIHS Low Speed – Rear

The low speed IIHS rear load case is set up the same as described for the front impact load cases.

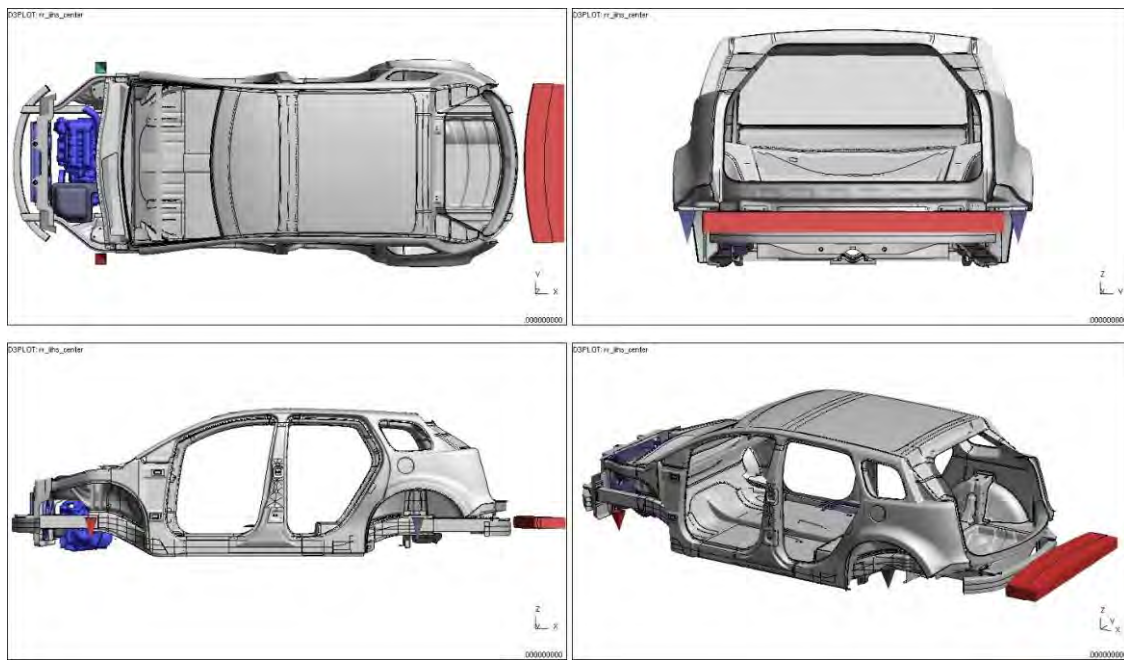

Figure 4.2.5.13.a: IIHS, low-speed rear test model setup ('full impact')

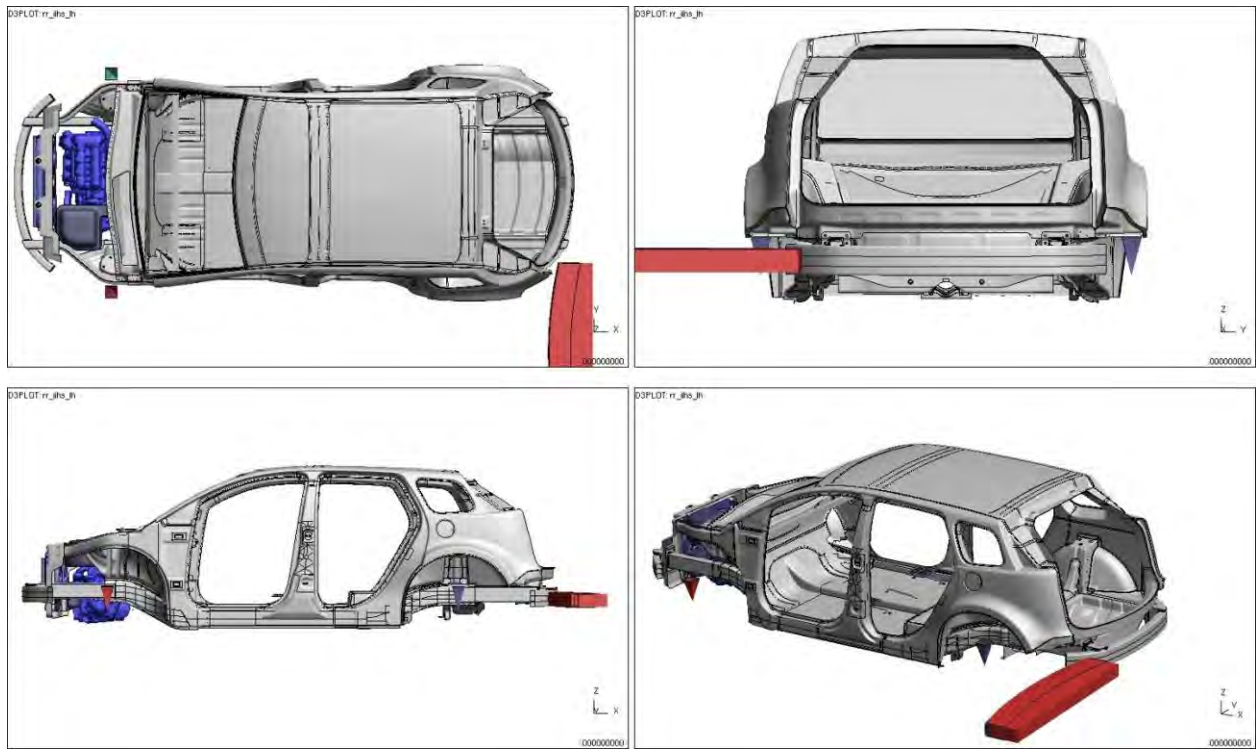

Figure 4.2.5.13.b: IIHS, low-speed rear test model setup ('offset impact')

4.3. CAE Analysis

CAE analyses were performed for each of the specified load and impact cases, but direct comparisons to current production vehicles cannot be made for each case. Lotus can however, explain the facts behind the results.

For all of the FMVSS high speed crash load cases analyzed, the actual pass/fail criteria are judged on occupant injuries. This was beyond the scope of the project as Lotus was contracted to evaluate the lightweight structure itself. Occupant injuries could not be evaluated, but structural performance can be compared to available NCAP test data. The same comparison cannot be made to FMVSS data as this information is not released to the public domain and remains with the individual OEMs. [Based on these analyses, the performance of the Phase 2 HD vehicle is predicted to be comparable to vehicles currently in production.](#)

Energy balances were also performed on each crash simulation to ensure the calculations followed the laws of physics. The way the software carries out its millions of calculations can lead to apparent increases in total energy. Total energy should remain the same, but kinetic energy will decrease and internal energy will increase as the crash occurs. The kinetic energy is absorbed by the crash structure deforming, frictional sliding, compression of springs, etc. thereby increasing internal energy.

In simplistic terms, the energy balance is perfect if:

$$\text{Total Energy} = \text{Initial Total Energy} + \text{External Work}$$

Or if the energy ratio is equal to 1.0. This energy ratio is used in the LS-DYNA[®] software. The software tracks all of the various types of energy such that the full energy balance used is:

$$\underbrace{\text{Energy}_{\text{kin}} + \text{Energy}_{\text{int}} + \text{Energy}_{\text{si}} + \text{Energy}_{\text{rw}} + \text{Energy}_{\text{damp}} + \text{Energy}_{\text{hg}}}_{\text{Total Energy (E}_{\text{total}})} = \text{Energy}_{\text{kin}}^0 + \text{Energy}_{\text{int}}^0 + \text{Work}_{\text{ext}}$$

- Where:
- Energy_{kin} = current kinetic energy
 - Energy_{int} = current internal energy
 - Energy_{si} = current sliding interface energy (including friction)
 - Energy_{rw} = current rigid wall energy
 - Energy_{damp} = current damping energy
 - Energy_{hg} = current hourglass energy
 - Energy_{kin}⁰ = initial kinetic energy
 - Energy_{int}⁰ = initial internal energy
 - Work_{ext} = external work

Internal energy includes elastic strain energy and the work done in permanent deformation. External work includes work done by applied forces and pressures as well as by velocity, displacement, or acceleration boundary conditions applied to the model.

A satisfactory energy balance is not a predictor of acceptable impact performance but simply verifies that the model behavior is consistent with the laws of physics and that there is no loss or gain of energy.

4.3.1. FMVSS 208: 35 mph Front Impact (0°/30° rigid wall, offset deformable barrier)

The termination time for this CAE analysis is 0.1 seconds, by this time the vehicle is rebounding from the wall. This is confirmed by checking the time to zero velocity (TTZ) which occurred at 59.5 ms (shown later). The following image shows the vehicle at the analysis termination time.

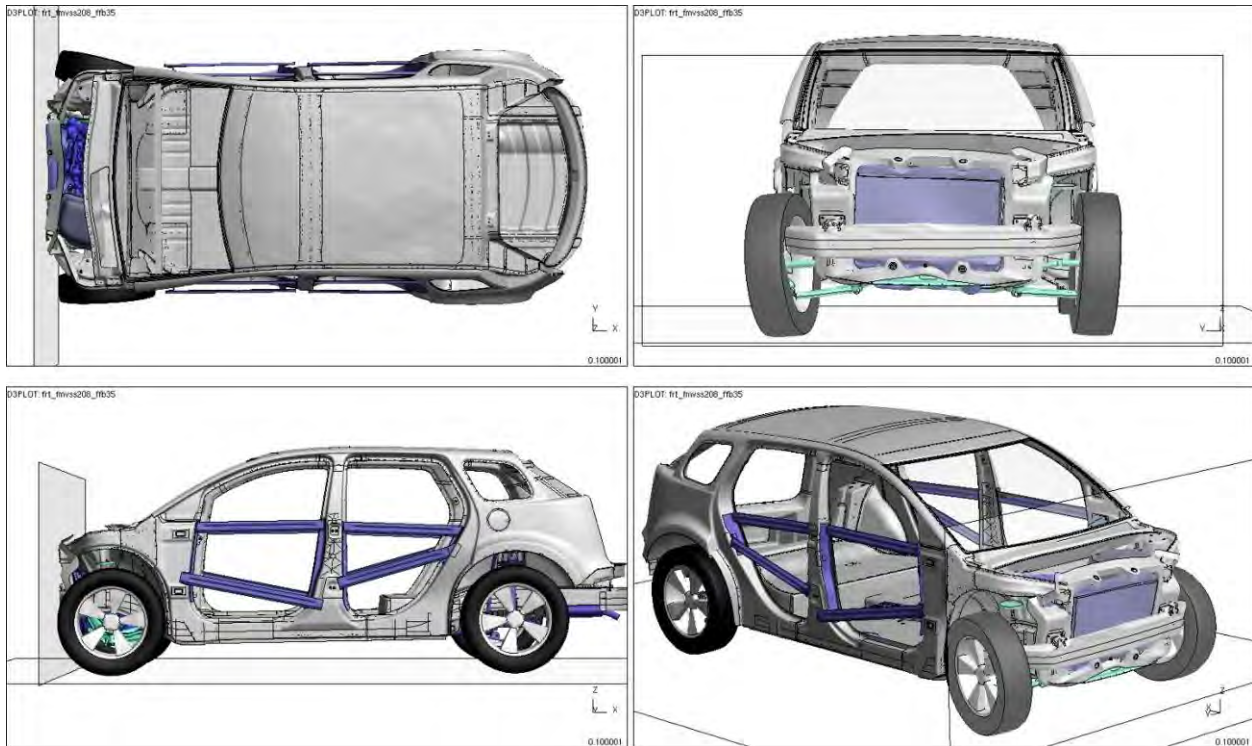

Figure 4.3.1.a: Vehicle deformation (t=0.1 s) after frontal impact

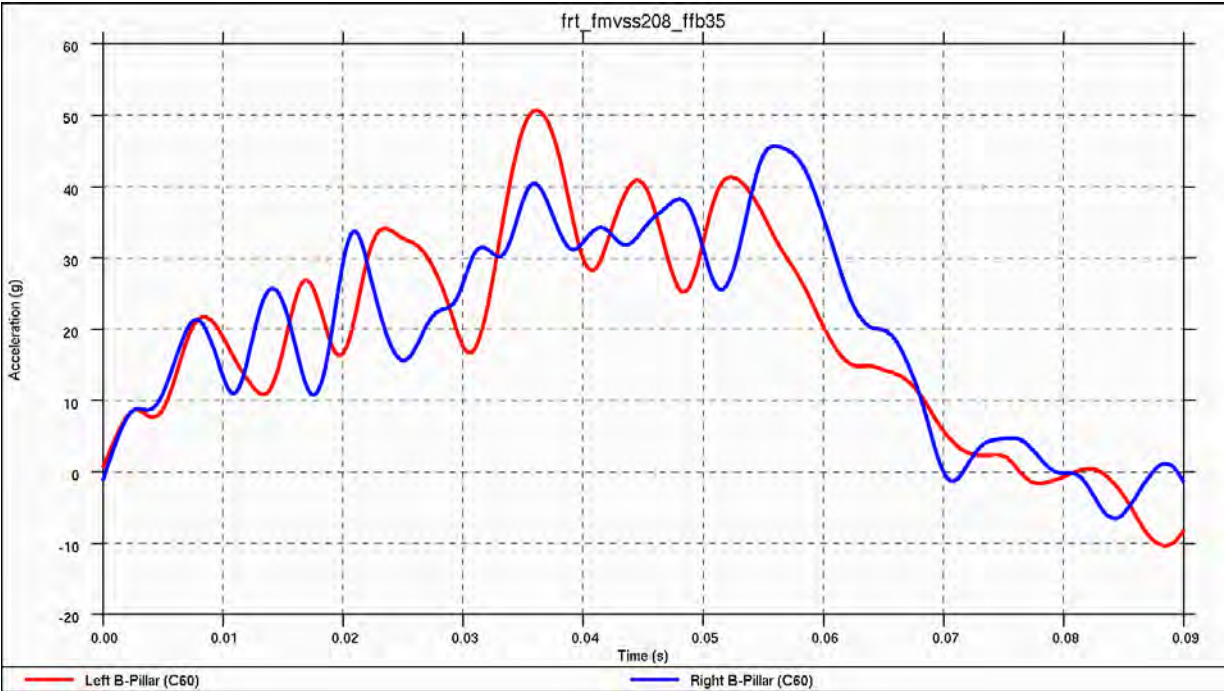

Figure 4.3.1.b: Vehicle acceleration pulse during frontal impact

The red and blue lines on the graph above are the acceleration measured at the bottom of the B pillar close to the rocker for the left and right hand side. These points are taken as there is little or no deformation in the frontal impact load case. Most of the vehicle structure is symmetrical, but the engine is not creating asymmetrical acceleration pulses. The peaks represent specific events during the impact.

- I. First peak of 8.8 G at 2.5 ms is due to the front bumper armature deforming.
- II. Second peak of 21 G at 8.0 ms is the initiation of crush in the bumper brackets.
- III. Once the bumper brackets have crushed (at 16 ms) crush initiation starts in the main rails which generate the third peak (21 G).
- IV. As the main rails continue crushing load is transmitted through the front suspension sub-frame structure which results in a peak at 22 ms of 29 G.
- V. The peak of 45.5 G at 36 ms due to the engine loading due to contact through the radiator fans/core to the rigid wall.
- VI. When contact between the engine and the dash panel occurs at 45 ms it results in a 37 G peak.
- VII. The main rails bottom out resulting in the final peak of 40 G at 55 ms.

Averaging the left and right accelerations provides the pulse shown below.

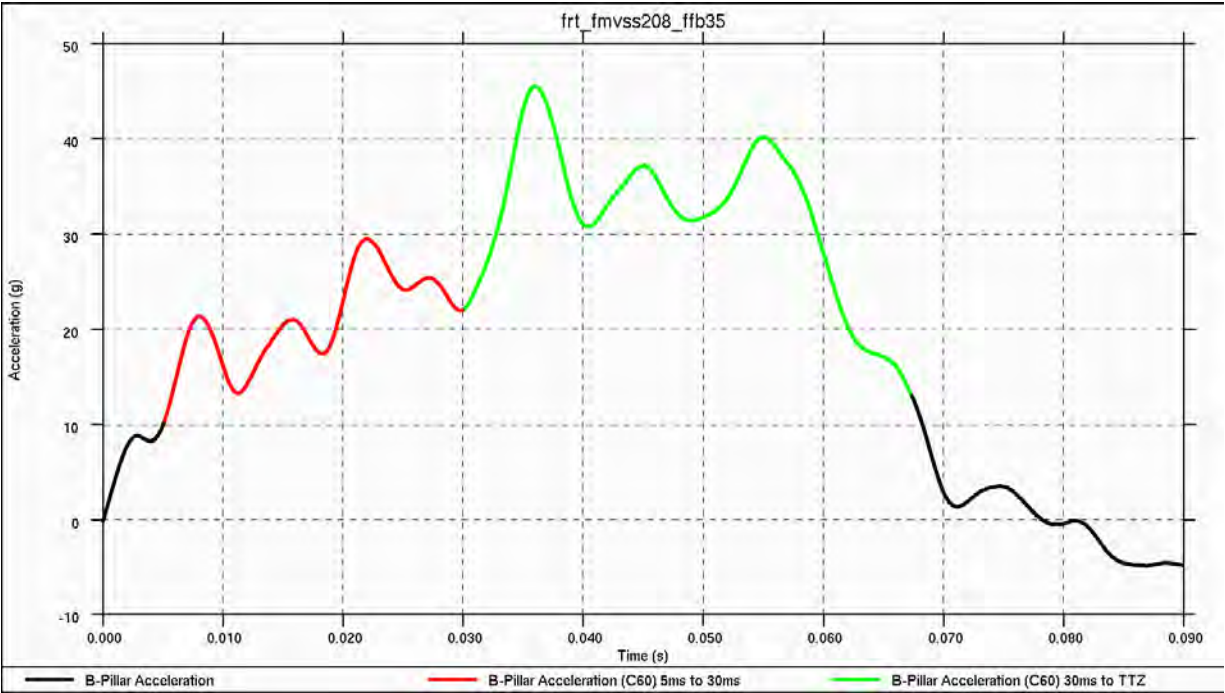

Figure 4.3.1.c: Average vehicle acceleration pulse during frontal impact

The overall average acceleration for the entire impact was 26.7 G. The average initial acceleration (5 to 30 ms) was 20.9 G. The average acceleration from 30 ms to TTZ was 34.7 G. In this case TTZ was 59.5 ms as shown in the graph below. After 59.5 ms, the vehicle has rebounded from the wall and started to travel in the opposite direction.

Based on the average acceleration pulse peaks and the overall average accelerations, this vehicle exhibits passing structural performance for the 35 mph FMVSS 208 impact.

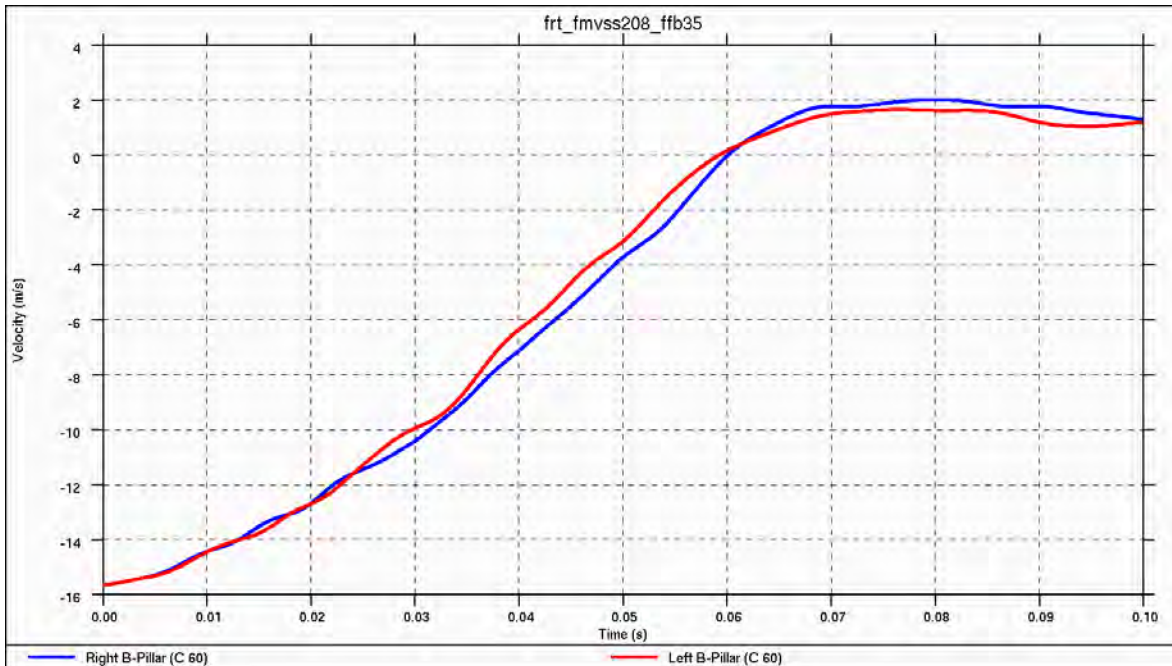

Figure 4.3.1.d: Vehicle velocity during frontal impact - time to 0 velocity (TTZ) = 59.5 ms

A sensitivity analysis was performed to determine how the gauge size of the front structure affects the crush pulse. The chart below shows the effect of an approximate 10-percent reduction in material thickness for the bumper crush cans and the main rails on the FMVSS 208 Flat Frontal 35-mph test. This analysis was run on an earlier model (V23). The chart below shows the resultant pulses for a model with reduced gauge main rails, vertical walls and bumper cans (green pulse) and a reduced gauge model with only the bumper cans and main rails down-gauged (blue pulse). The baseline model is indicated by the black pulse.

The results of this study indicate that a 10% change in material thickness in the front crush zone can reduce the acceleration level by as much as 30%. The reason for this gauge study was to investigate ways to reduce the initial acceleration to prevent deploying the air bags prematurely. Early deployment can result in needing to replace an expensive system when the seat belts alone would have provided sufficient occupant protection.

The front structure design is tunable to provide a substantial range of deceleration levels for air bag deployment in the initial phases of an impact event. The initial material thicknesses (listed on Figure 4.3.1.e. and represented by the black curve) were retained for durability/fatigue conformance. TRW reviewed the baseline pulse (black line) and determined that it was consistent with their current technologies used on production steel bodied vehicles.

This was a conservative approach that added mass. Durability/fatigue analyses were beyond the scope of this project and the thicker rail and crush can materials were considered the best approach for the overall structure. Fatigue and durability analysis

could potentially indicate that thinner wall material may be acceptable and further reduce the BIW mass.

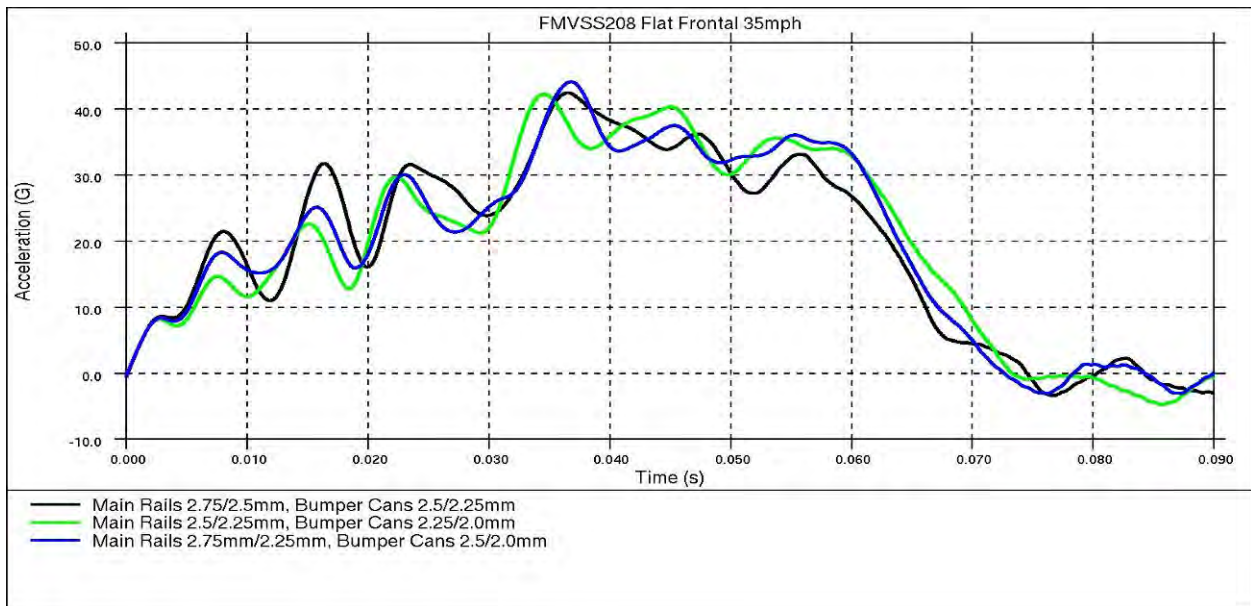

Figure 4.3.1.e: Vehicle acceleration during frontal impact

Ver #23 'std' – black pulse:

Initial peak (bumper cans) @ 8 ms – 21.4 G; second peak (main rail) @ 16 ms - 31.8 G

Ver #23 – green pulse (as 'std' with main rail/bumper can vertical wall down-gauged 0.25 mm):

Initial peak (bumper cans) @ 8 ms - 18.3 G; second peak (main rail) @ 16 ms - 25.2 G

Ver #23 'std' – blue pulse (as 'std' with main rail/bumper can down-gauged 0.25 mm):

Initial peak (bumper cans) @ 8 ms - 14.7 G; second peak (main rail) @ 16 ms - 22.6 G

The maximum dynamic crush of the vehicle during this 35-mph frontal impact was 555 mm. It was calculated based on the maximum displacements shown in Figure 4.3.1.f. The impact deceleration is related to the crush zone length. The longer the crush zone, the more time there is to absorb the impact energy and to reduce the deceleration levels.

The full crush zone of the vehicle is not fully utilized under the flat frontal impact load case as there is not enough mass in the vehicle to enable this to occur. One of the governing factors for the design was that it was based upon a vehicle with proportions such that it would use up all of the available space under the front impact loading. The process for

producing extruded aluminum as used in the front rails dictated a minimum gage that could be used while assuring no issues due to material warping during the manufacturing phase. This led to a stiffer structure in the front rails that was not optimal for the vehicle mass.

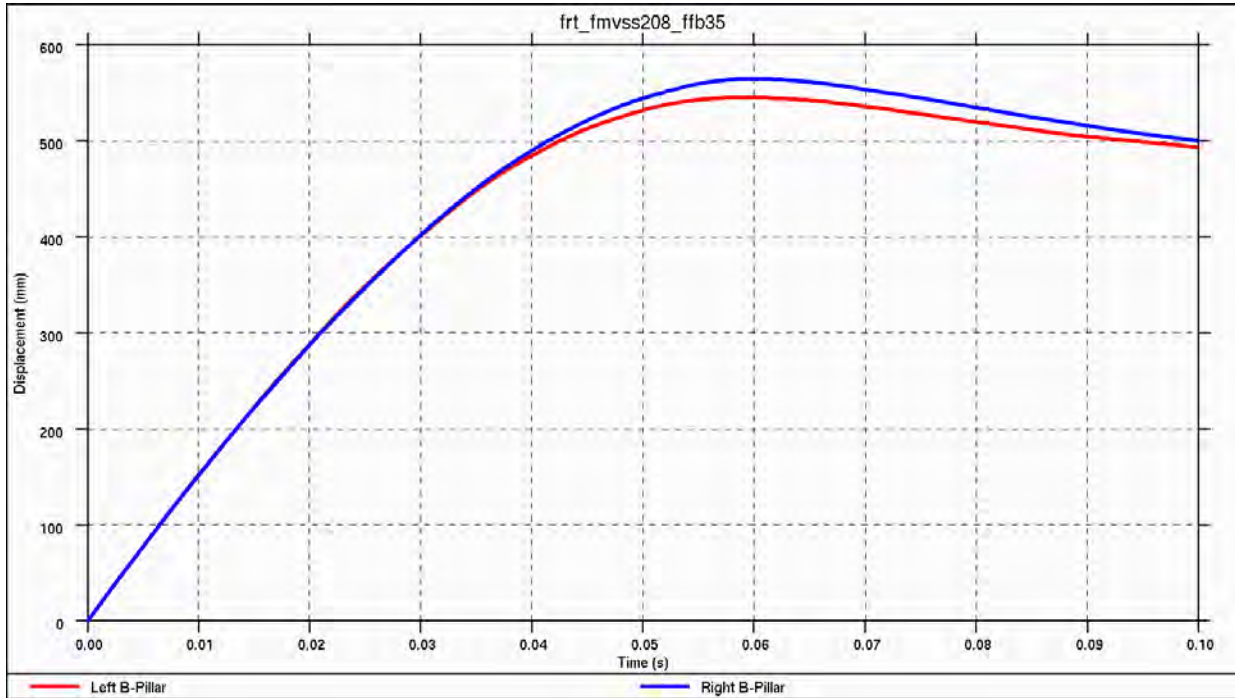

Figure 4.3.1.f: Vehicle displacement from frontal impact - max dynamic crush = 555 mm

Measuring the amount of intrusion into the dash for this load case showed minimal levels of dash displacement (<20 mm), a maximum of approximately 10 mm in the driver footwell and a maximum of approximately 15 mm in the passenger footwell. In English units this is less than one-inch maximum deflection (occurs in an unoccupied area) and a worst-case deflection of 0.6 inches in the footwell. This level of intrusion indicates that the front structure is absorbing the impact energy and not transferring it into the dash area. The lower A-pillar structure shows no visible damage after this impact.

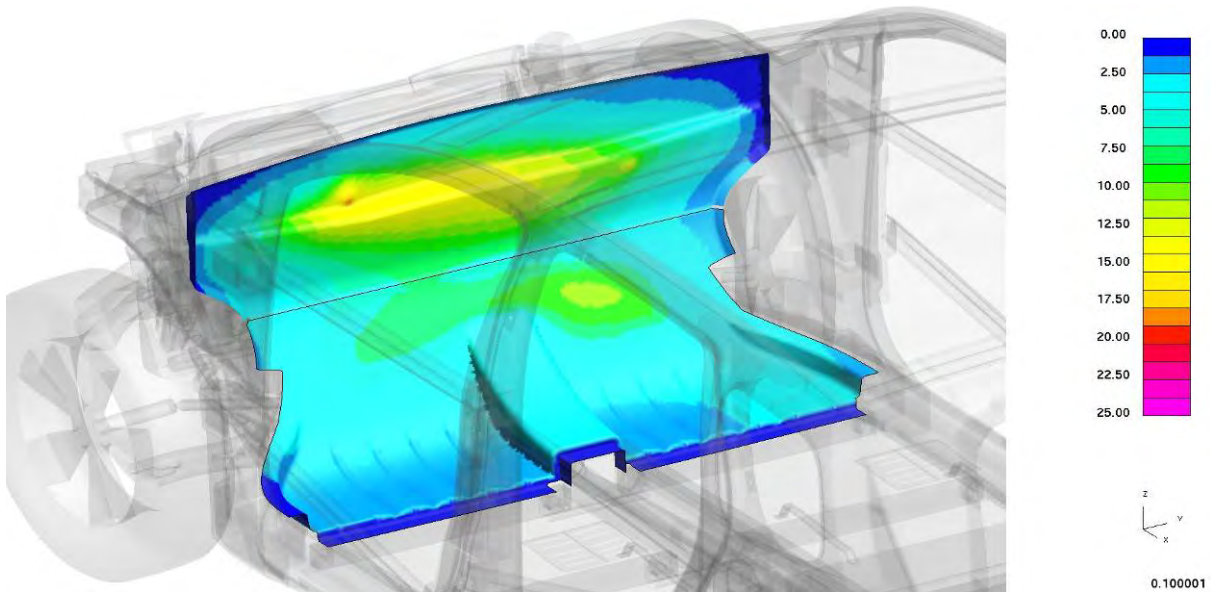

Figure 4.3.1.g: CAE dash intrusion analysis after frontal impact

The maximum fuel tank plastic strains were less than 10 percent (100 on the bar scale below equals 10-percent strain). This indicates that there should be no failure of the tank due to contact with any of the surrounding components. The tank mounting system created the peak strains; there was no body-to-fuel tank contact. An inflatable bladder modeled inside the tank indicated that there was minimal pressure rise in the tank during impact (<0.2 psi).

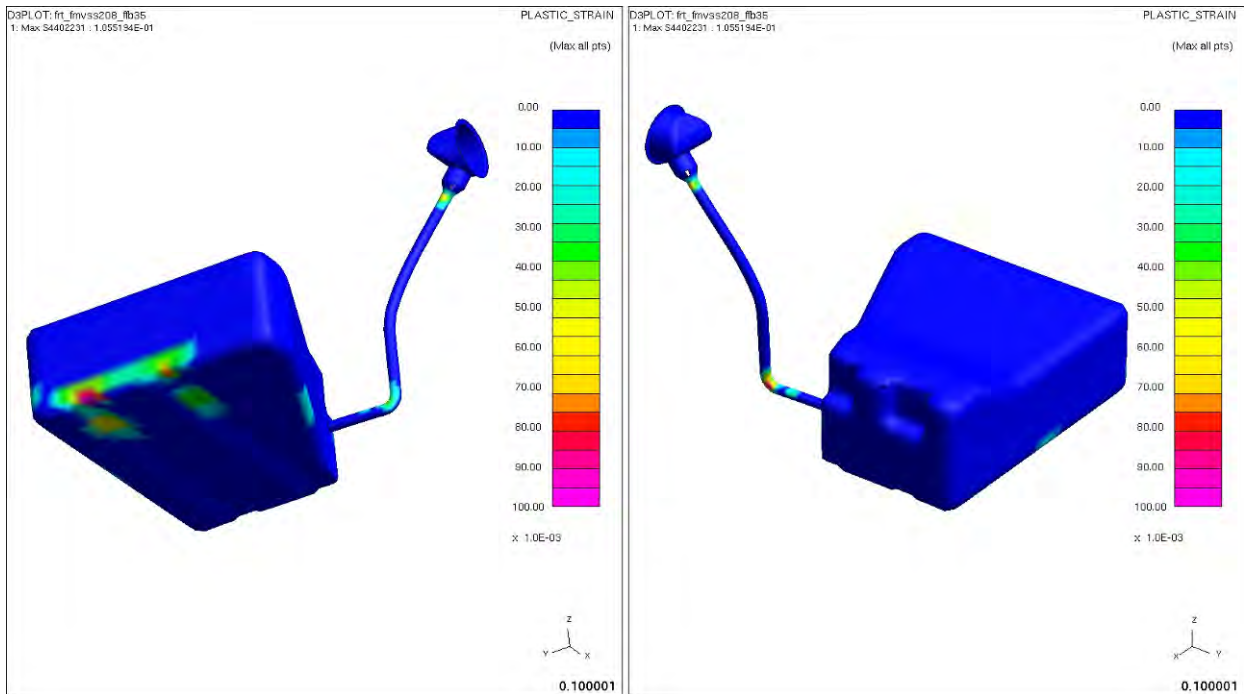

Figure 4.3.1.h: Fuel tank plastic strain after impact

In this impact load case the majority of the energy is absorbed by the front end body structure and through the sub-frame. The top ten most energy absorbent components in the body structure were extracted from the analysis and evaluated for relative performance. This exercise showed that besides the front bumper, bumper brackets and main rails, the magnesium front end module (FEM) was another body component that absorbed a significant amount of the impact energy.

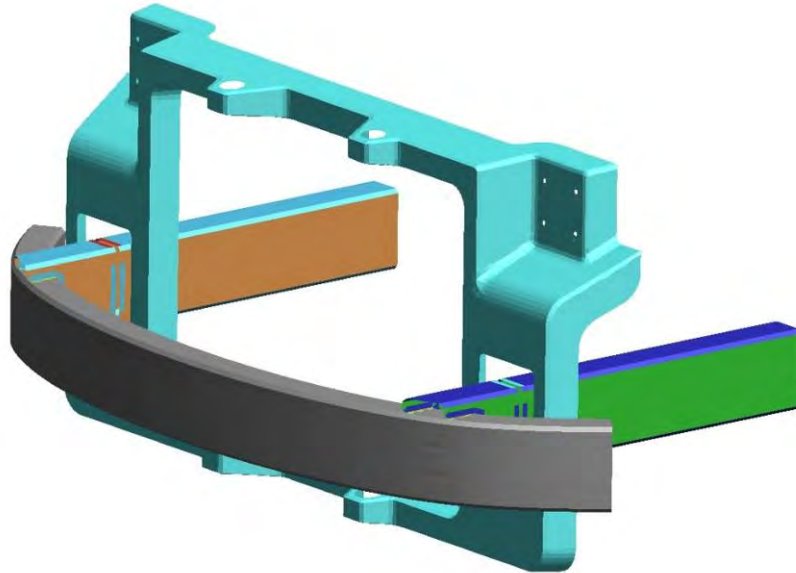

Figure 4.3.1.i: Main energy absorbing frontal body structure

An energy balance plot was extracted from the analysis to check for any mathematical instability possibly present in the model, leading to unrepresentative behavior. This is shown below; it verifies that the model is performing with no loss or gain of energy..

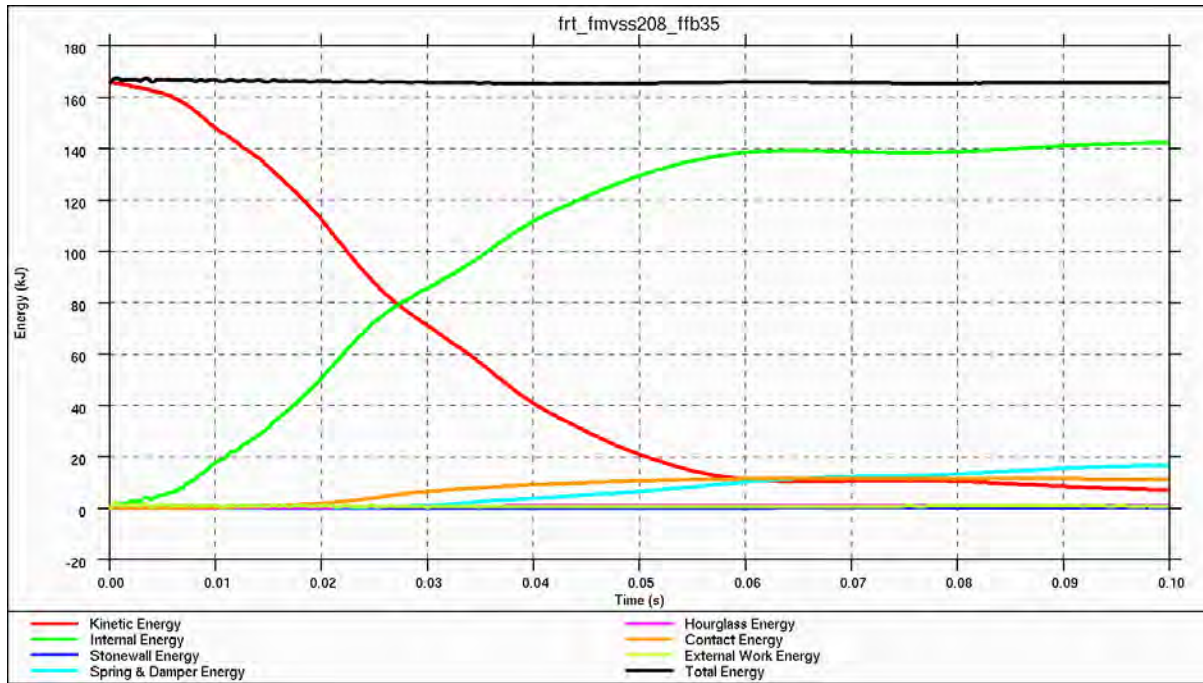

Figure4.3.1.j: Energy balance for frontal impact

4.3.2. FMVSS 208: 25 mph Offset Deformable Barrier

This analysis is run to 0.15 s as it is a longer duration crash event than the 35-mph load case. The actual time to zero forward velocity is predicted to be 0.117 s.

The barrier used in this load case is deformable and absorbs energy as it deforms. This barrier can absorb up to 50 percent of the total kinetic energy during impact making this a less severe impact than the 35-mph, rigid-wall load case.

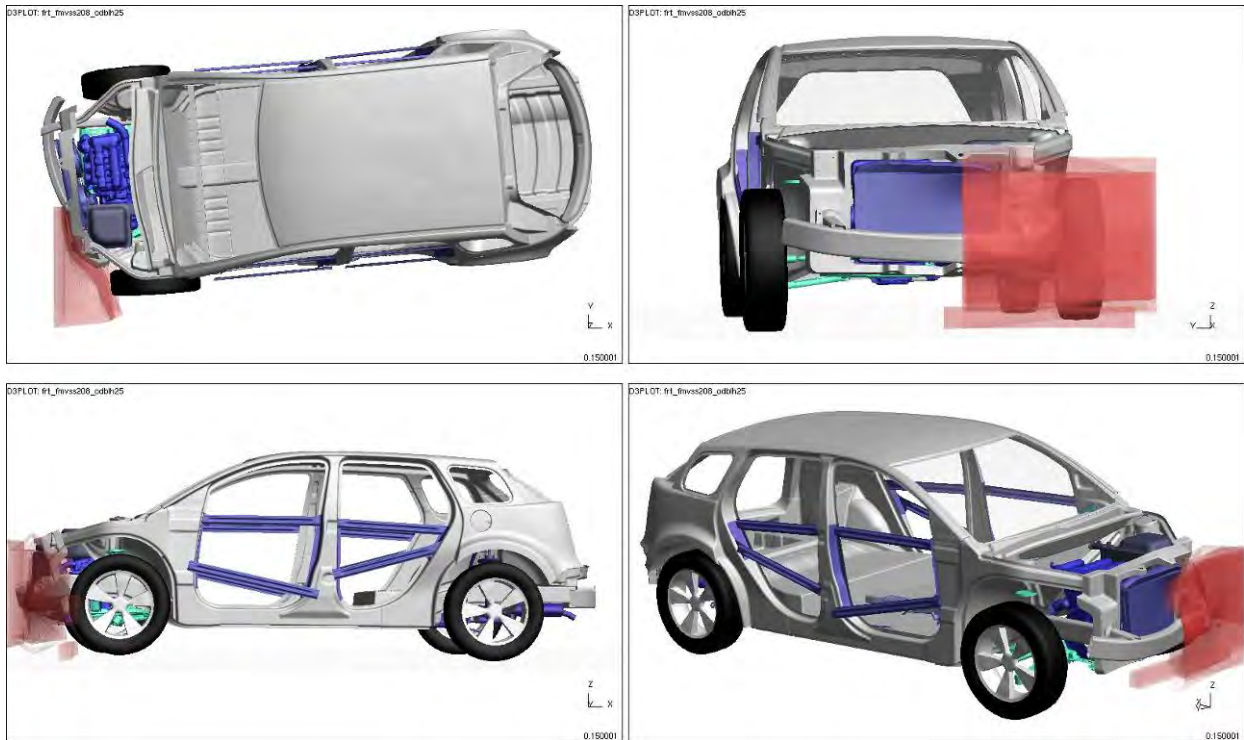

Figure 4.3.2.a: Vehicle deformation (t=0.15 s) after 40-percent overlap frontal impact

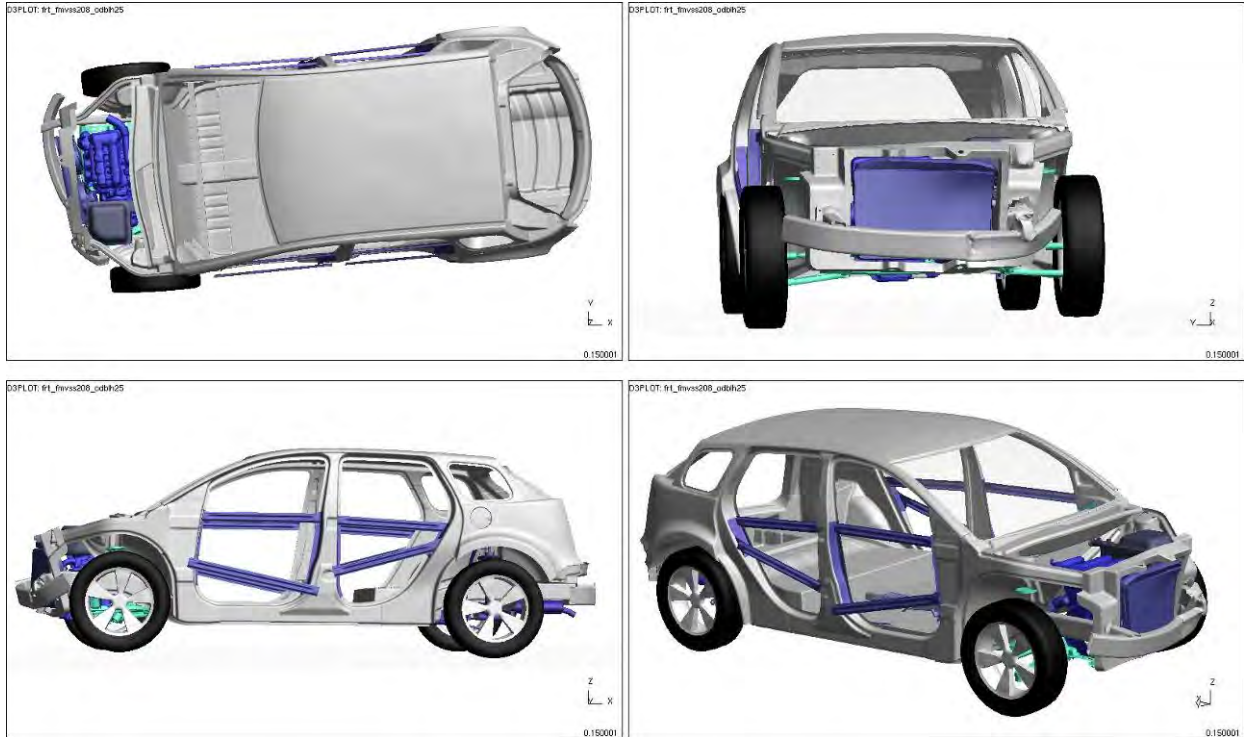

Figure 4.3.2.b: Vehicle deformation ($t=0.15$ s, barrier not shown) after 40-percent overlap frontal impact

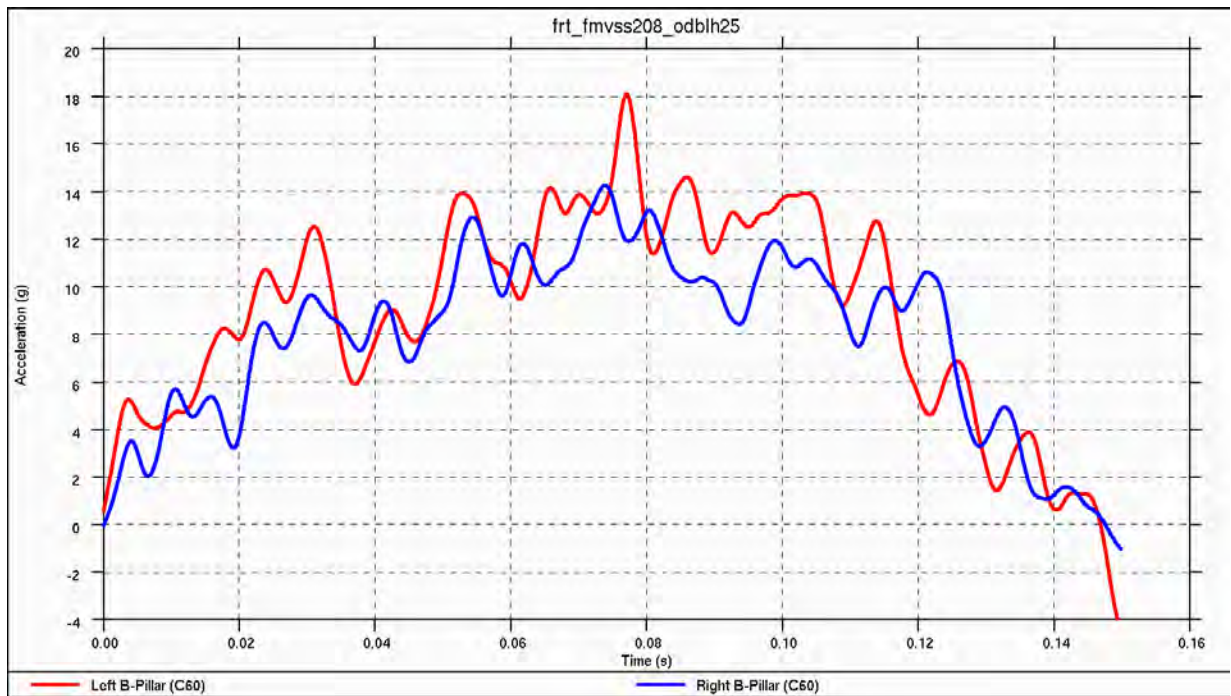

Figure 4.3.2.c: Vehicle acceleration pulse during 40-percent overlap frontal impact

Due to the asymmetry of the barrier, the left and right pulses were not identical and are represented in red and blue, respectively, on the graph above. In addition, the left side pulse is higher since the barrier overlaps the vehicle on the left side. This results in more loading going directly into the left side of the vehicle.

The peaks on the left pulse (in red on the graph) are used to describe the events during the impact since this is an offset impact.

- I. The first peak of 5 G at 4 ms was generated by the initial crush of the deformable barrier. Note the deformable barrier is made up of a main block and a bumper block. At 4ms the vehicle is in contact with the barrier bumper block but the initial crush began on the main barrier block, as this was less stiff.
- II. The acceleration increases to 10 G at 24 ms until the bumper block on the barrier starts to crush. Through this time, there was no deformation on the vehicle.
- III. At 31 ms the first vehicle deformation occurs, the front-end-module (FEM) and radiator take some load, this corresponded with the acceleration peak of 12.5 G. The acceleration drops as material fracture of the FEM occurs in a number of locations.
- IV. The pulse increases to a peak of 9 G at 42.5 ms, which corresponds to when the left bumper bracket starts to deform.
- V. As the crush on the softer main barrier block progresses it begins to bottom out causing the the next peak of 14 G at 53 ms.
- VI. Between 63 ms and 72 ms, crushing in the stiffer bumper barrier block continued until this bottomed out. Once this had occurred the stiffer vehicle components started to deform. At 78 ms there is a peak pulse of 18 G when the front suspension sub-frame, front bumper, and main rails start deforming.
- VII. The next 2 peak acceleration pulses observed after the highest peak were caused by the deformable barrier coming into contact with the left tire (at 86 ms and 114 ms).

Most of the kinetic energy, was absorbed by 120 ms and the vehicle velocity graph showed that the left B-Pillar velocity was at zero at 117 ms.

Averaging the left and right accelerations provides the pulse shown below.

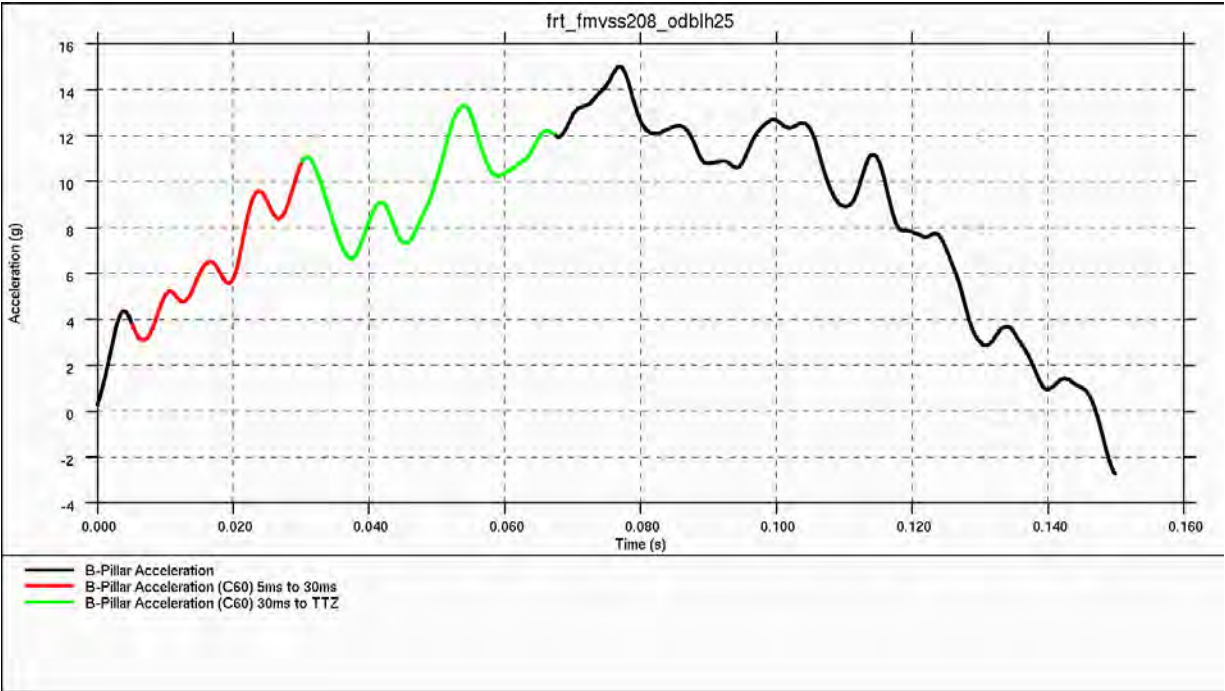

Figure 4.3.2.d: Average vehicle pulse during 40-percent overlap frontal impact

The overall average acceleration for the entire impact was below 10 G. The average initial acceleration (5 to 30 ms) was 6.5 G and the average acceleration from 30 ms to TTZ was 9 G. In this case TTZ was 117 ms shown in the figure below.

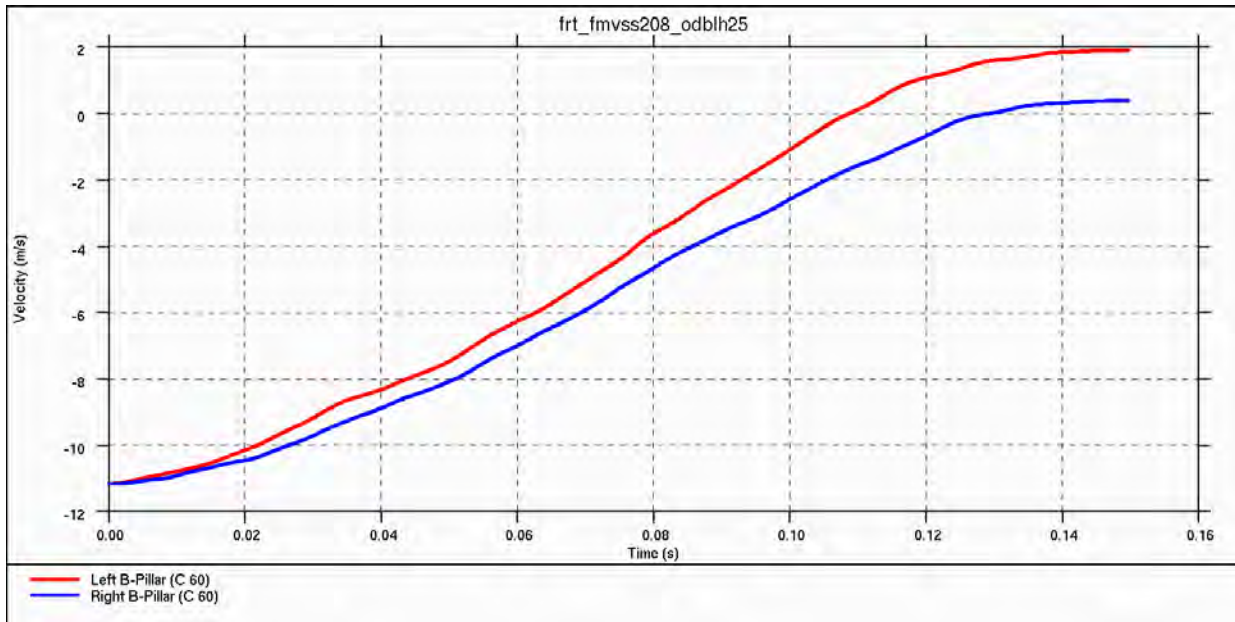

Figure 4.3.2.e: Vehicle velocity after 40-percent overlap frontal impact - time to zero (TTZ) = 0.117 s

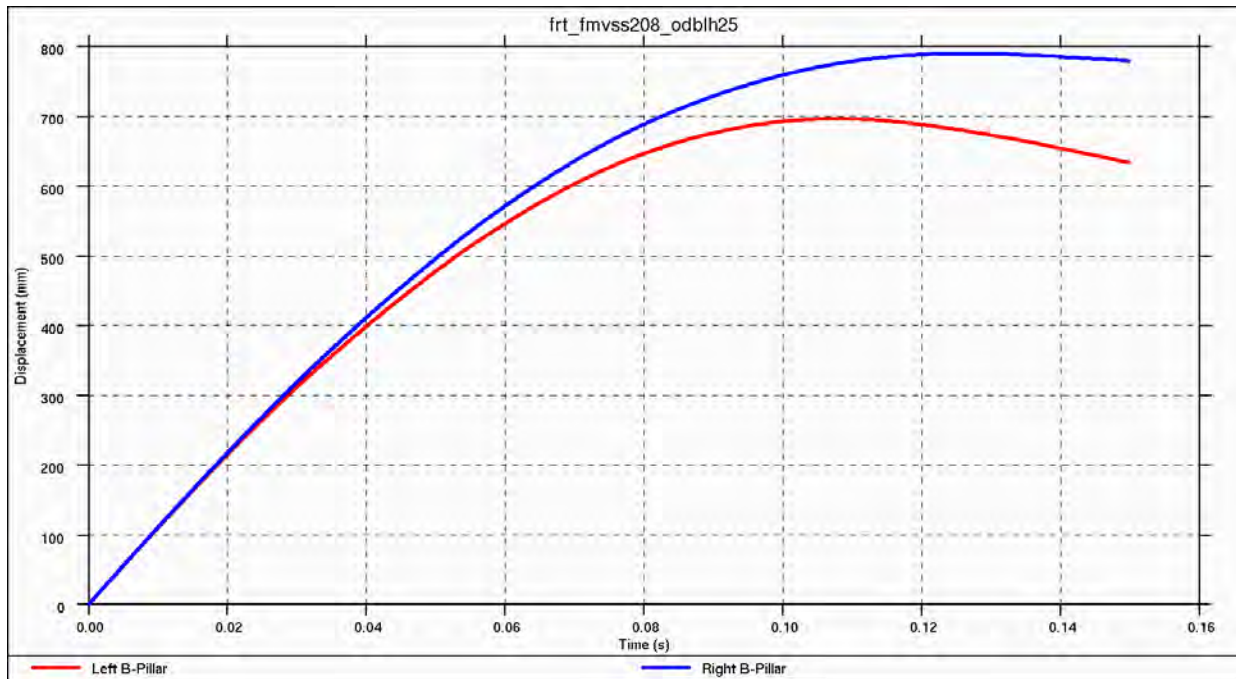

Figure 4.3.2.f: Vehicle displacement after 40-percent overlap frontal impact

The total dynamic crush cannot be calculated from the vehicle displacement graph as the barrier was deformable. The total vehicle dynamic crush was estimated to be around 180 mm using the animation result files.

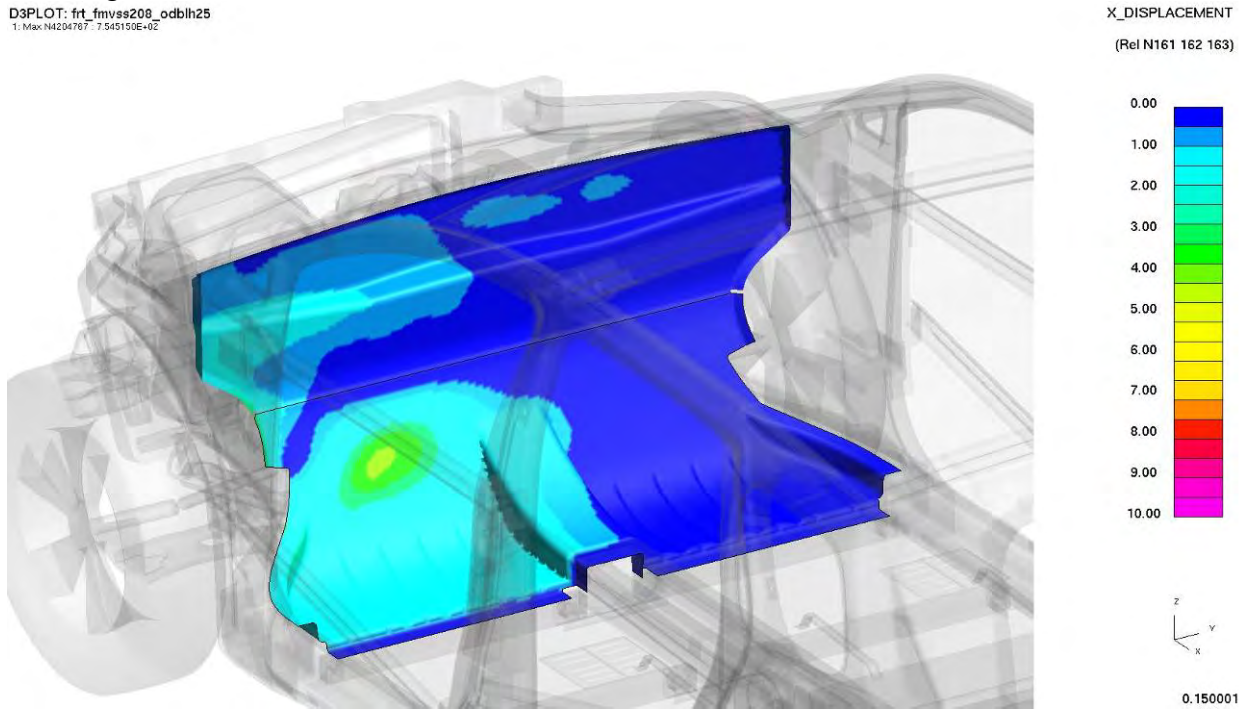
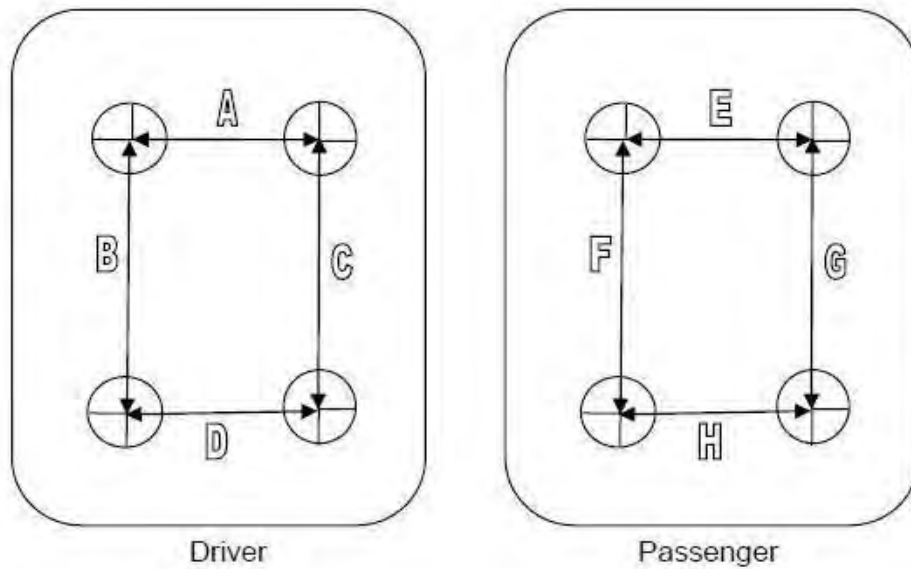

Figure 4.3.2.g: CAE dash intrusion analysis after 40-percent overlap frontal impact

The dash intrusion is very low at approximately 5 mm. This is because the barrier absorbed 50 percent of the kinetic energy and the front structure of the vehicle was stiff enough, i.e., did not deform extensively during this time, and had sufficient crush space in front of the passenger compartment to absorb the remaining kinetic energy.

For comparison, the dash intrusion levels of the 2009 Toyota Venza measured by NCAP exceed the CAE-predicted values for the Phase 2 HD vehicle. The NCAP underbody floor analysis is shown in Figure 4.3.2.h below and shows the floorboard deformation measured, none of which is seen in the Phase 2 HD crash simulations.



UNDERBODY FLOORBOARD DEFORMATION

| Measurement | Pre-Test | Post-Test | Difference |
|-------------|----------|-----------|------------|
| A | 323 | 338 | -15 |
| B | 323 | 359 | -36 |
| C | 323 | 306 | 17 |
| D | 323 | 322 | 1 |
| E | 323 | 342 | -19 |
| F | 323 | 316 | 7 |
| G | 323 | 350 | -27 |
| H | 323 | 325 | -2 |

Figure 4.3.2.h: Toyota Venza NCAP dash deformation

The body structure components that absorb the majority of the energy are the front bumper, left bumper bracket, left main rails and the front end module (FEM), as shown below.

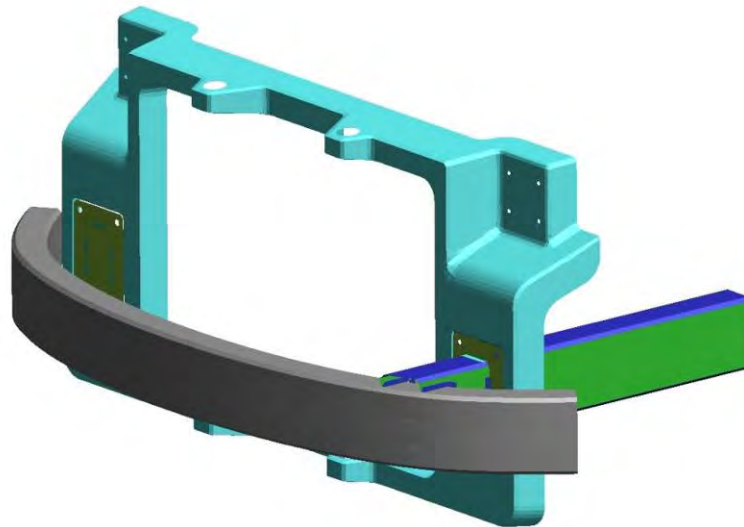

Figure 4.3.2.i: Main energy absorbing body structure – 40-percent overlap frontal impact

The energy balance for this analysis verified that no energy was lost or created.

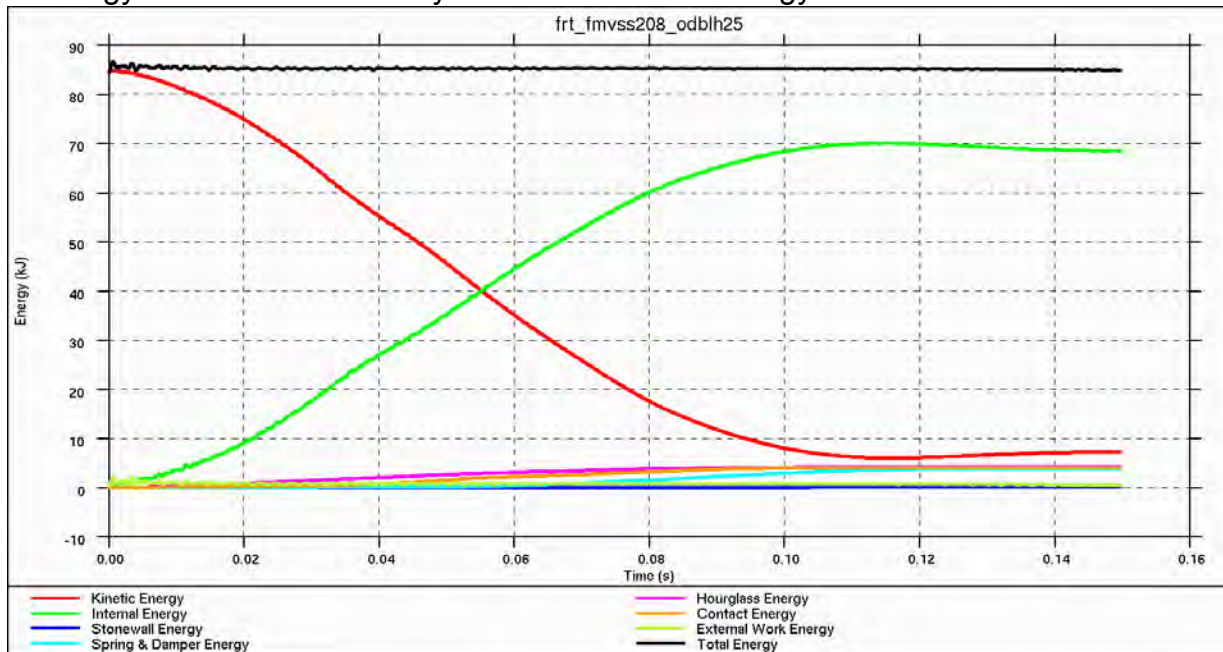

Figure 4.3.2.j: Energy balance for 40-percent overlap frontal impact

The information presented in this section shows how the Phase 2 HD vehicle performs in crash simulations, but gives little context for comparison. This context is however, hard to provide as the Phase 2 HD vehicle was tested without occupants and a restraint system to test dummy injury criteria as standard. The occupant restraint system and crash structure work in tandem, so the results here don't provide a complete safety picture. Forming and proving full vehicle safety was beyond the scope of this contract as it requires designing a full vehicle with seats, interior, and occupant restraints. While occupant protection cannot be fully proved in this study, the Phase 2 HD BIW performs no worse than vehicles currently in production, indicating that the vehicle could meet safety requirements, particularly since the safety system can be tuned to act based upon the specific vehicle acceleration pulses.

As the Phase 2 HD vehicle was tested without the occupant restraint system and occupants, no comparison of actual occupant test results can be made, but a comparison of crash structure acceleration data can be made.

A comparison of vehicular accelerations can be seen in Figure 4.3.2.k below. The figure shows a comparison between a 2009 Toyota Venza, 2007 Dodge Caliber, 2007 Ford Edge, 2007 Saturn Outlook, a 2009 Dodge Journey, and the Phase 2 HD vehicle. All of the standard production vehicles pass NHTSA safety criteria with four-star frontal crash ratings or above and the Phase 2 HD vehicle acceleration levels are comparable to those of the production vehicles. Based on this data and Lotus' engineering judgment, the Phase 2 HD vehicle is predicted to perform as well as or better than comparable vehicles on the market.

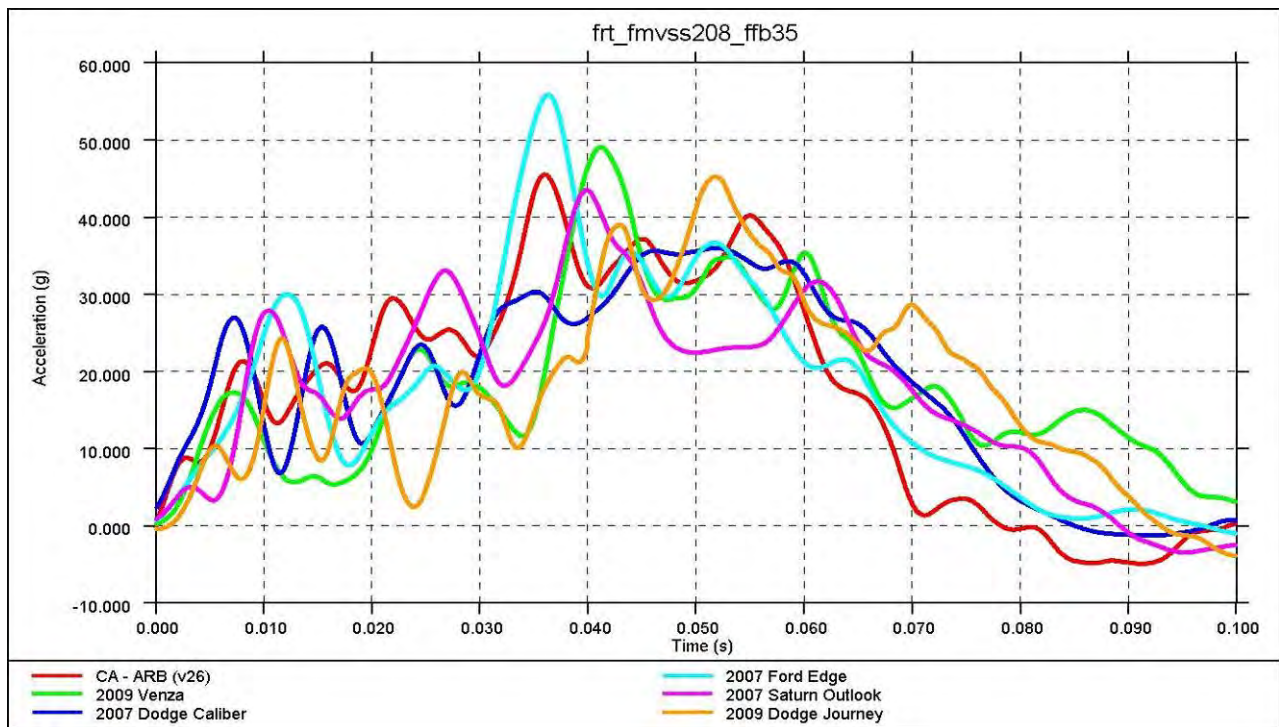

Figure 4.3.2.k: Comparison of production vehicle and Phase 2 HD crash accelerations

Figure 4.3.2.I below shows the upper and lower acceleration envelopes from the comparative data for FMVSS 208, 35-mph flat, frontal crash. This illustrates more clearly that the Phase 2 HD vehicle is comparable to already proven vehicles. In very few instances does the acceleration pulse for the Phase 2 HD vehicle exceed the envelope.

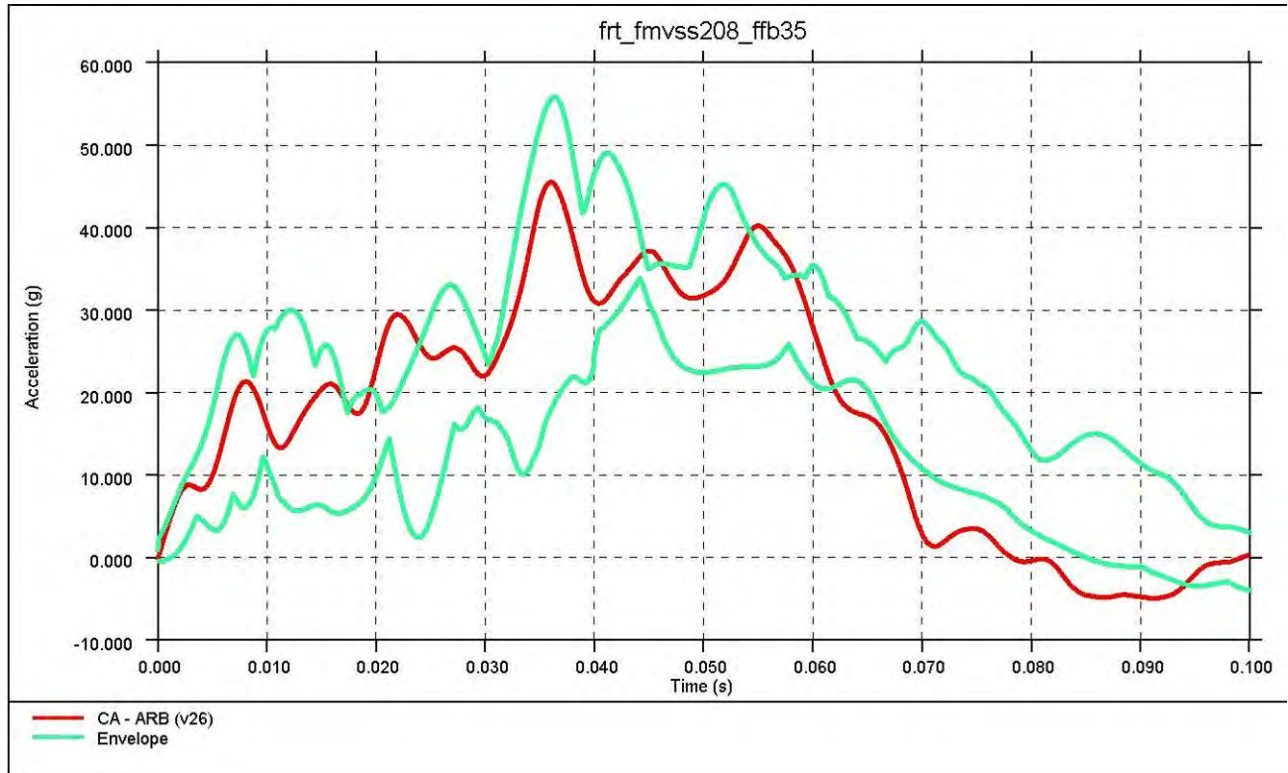

Figure 4.3.2.I: Comparison of production vehicle envelope and Phase 2 HD crash accelerations

4.3.3. FMVSS208: 25 mph 30° Flat Barrier – Left Side

The analysis is run for 0.12 s which is sufficient for all the deformation to have occurred, after this time the direction of the vehicle momentum is typically partially parallel to the angled barrier. The TTZ for this load case is at 0.076 s.

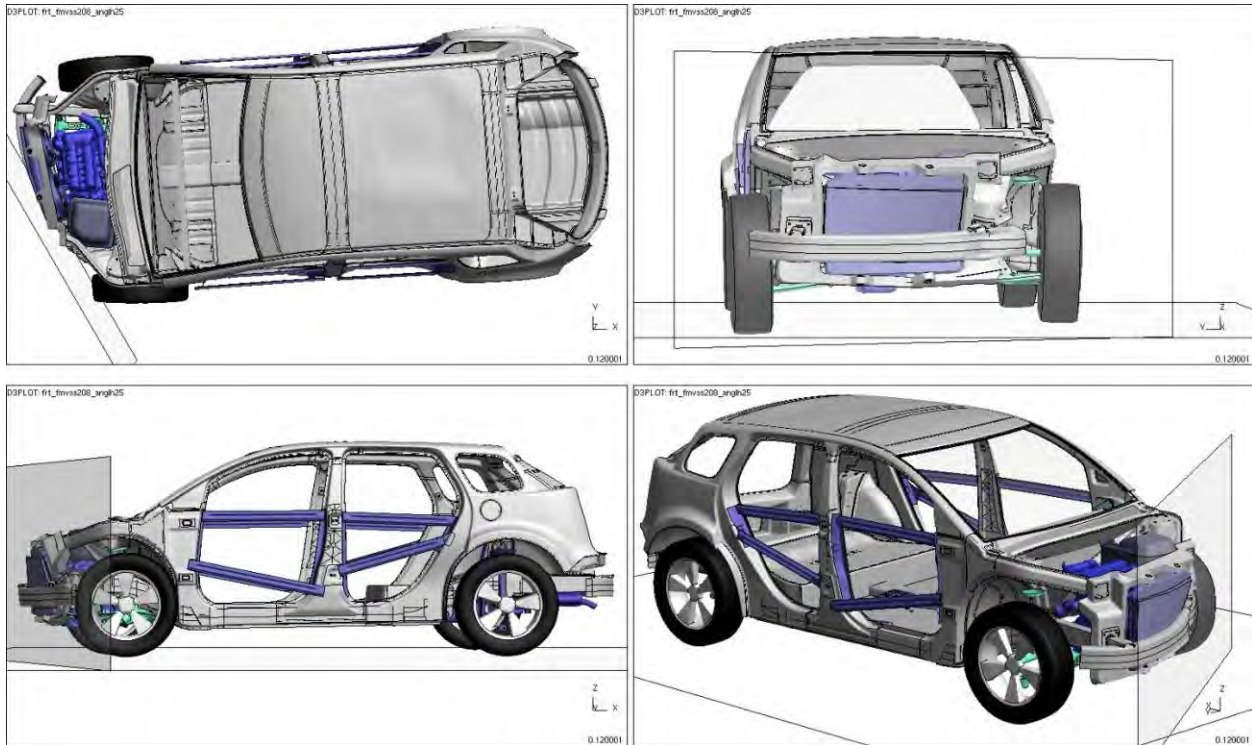

Figure 4.3.3.a: Vehicle deformation (t=0.12 s) after 30°, left-side frontal barrier impact

Very little or noticeable deformation occurred at the front door aperture, which indicates the vehicle will likely retain the frontal occupants.

The left and right acceleration pulses are plotted in red and blue on Figure 4.3.3.b below. They are asymmetrical because the engine and left side of the vehicle were the first contact points.

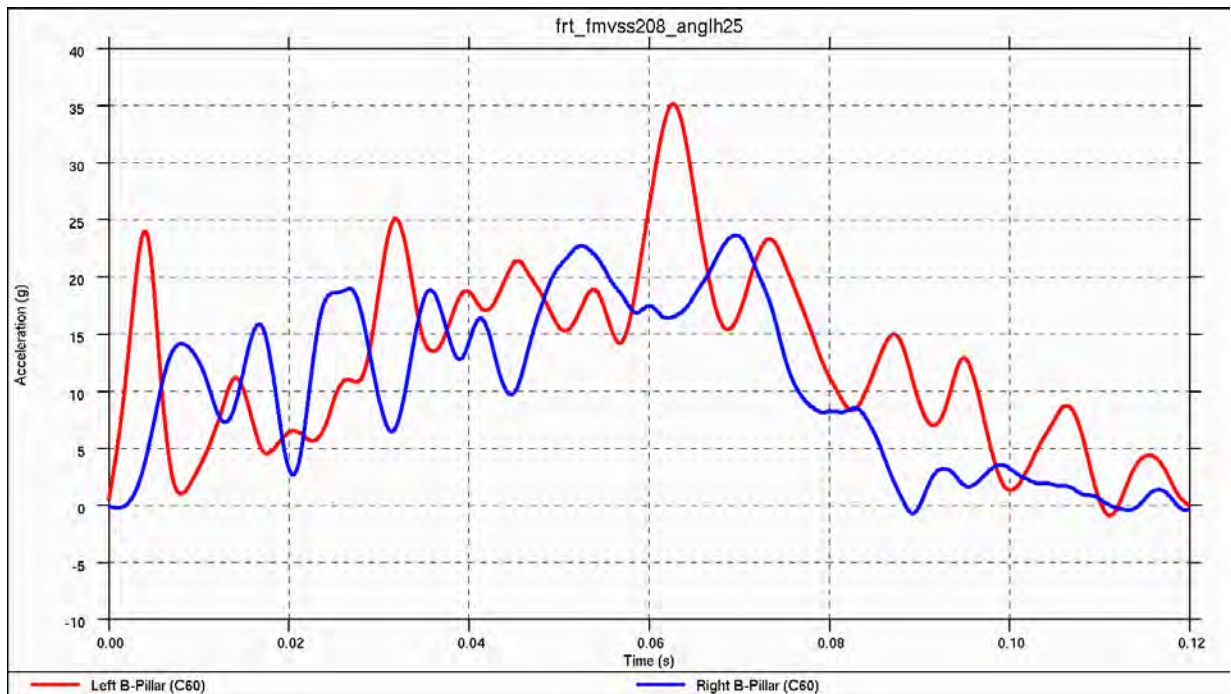

Figure 4.3.3.b: Vehicle acceleration pulse during 30°, left-side frontal barrier impact

The peaks on the left pulse (colored in red) are used to describe the events during the impact.

There are four significant acceleration pulse peaks at 4, 14, 32 and 63 ms generating 24, 11, 25 and 35 Gs, respectively.

- I. The first acceleration peak occurs when the front bumper begins deforming.
- II. The second acceleration pulse peak is due to the bumper bracket starting to deform (the load case is not perpendicular so there is some crush and bending occurring).
- III. The third acceleration pulse peak is due to the main rail on the left side bending along with the front suspension sub-frame.
- IV. The fourth acceleration pulse peak was created by the engine stacking up against the radiator and the barrier as well as the front suspension sub-frame bottoming out.

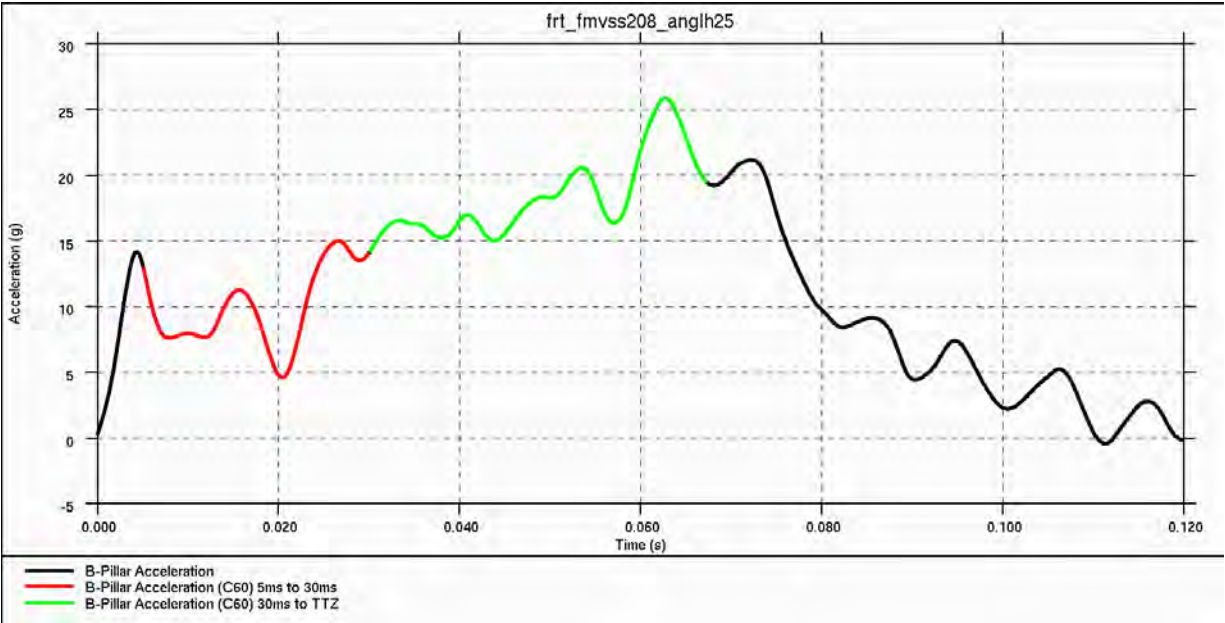

Figure 4.3.3.c: Average vehicle acceleration pulse during 30°, left-side frontal barrier impact

The overall average acceleration pulse is just below 19 G. The average initial acceleration (5 to 30 ms) was 9.9 G. The average acceleration from 30 ms to TTZ was 18.6 G.

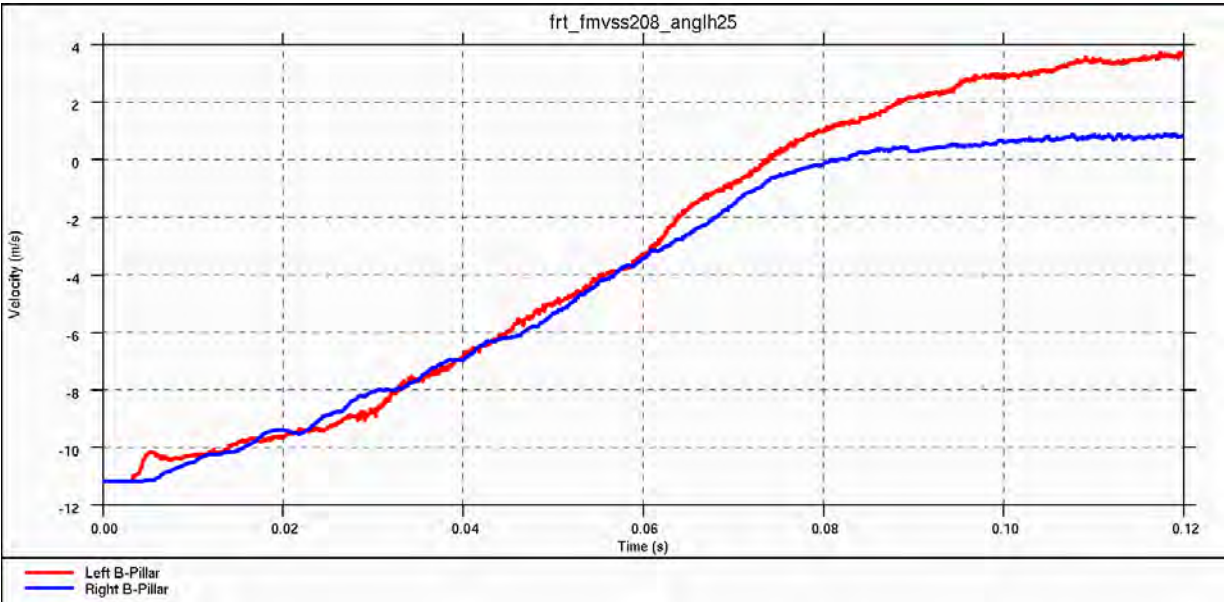

Figure 4.3.3.d: Vehicle velocity during 30°, left-side frontal impact - time to 0 velocity (TTZ) = 76 ms

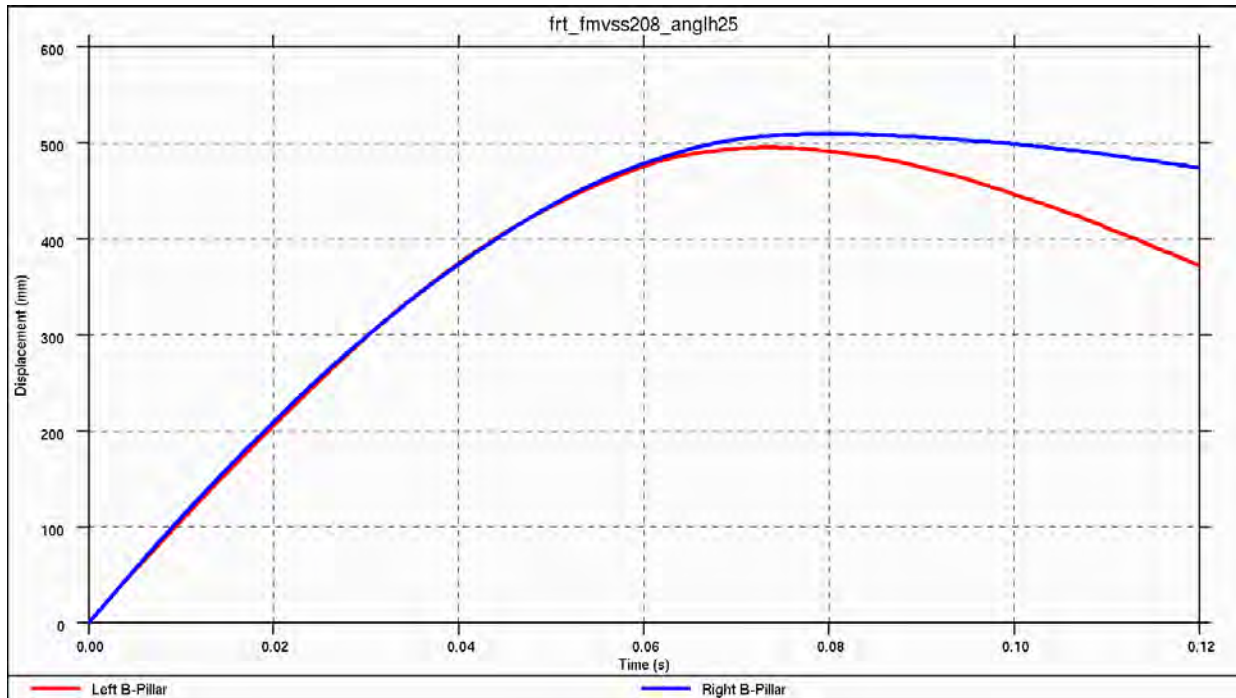

Figure 4.3.3.e: Vehicle displacement during 30°, left-side frontal impact – max dynamic crush = 500 mm

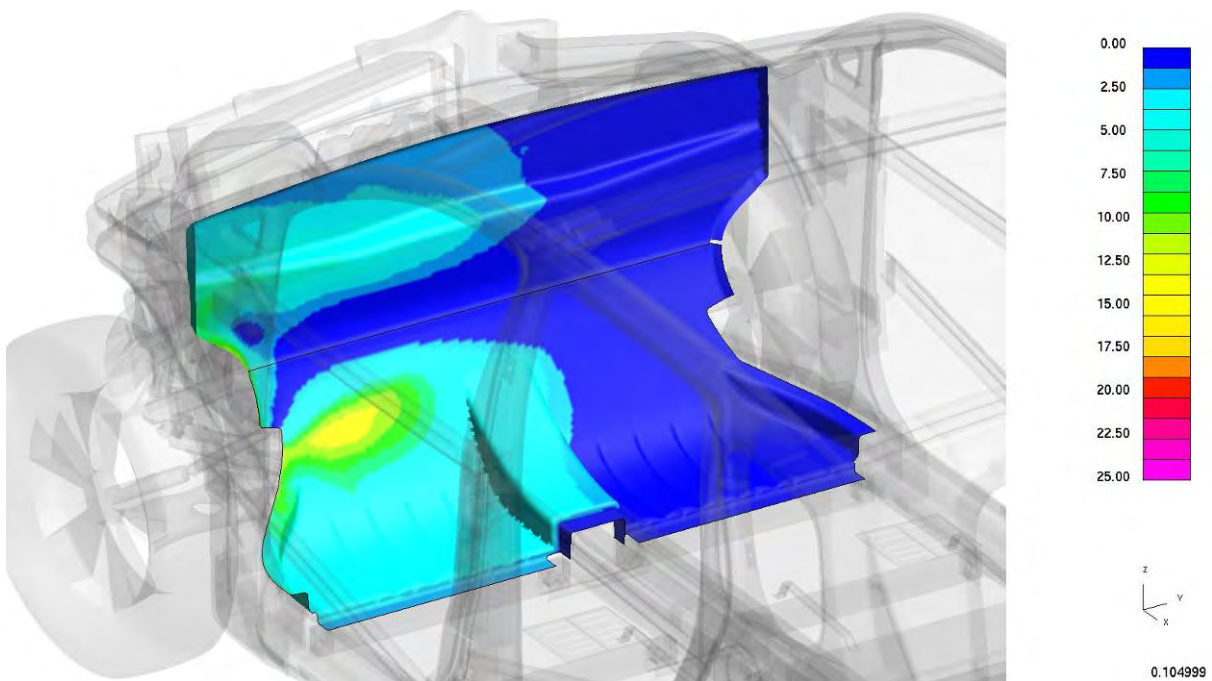

Figure 4.3.3.f: CAE dash intrusion analysis after 30°, left-side frontal impact

The intrusion into the dash for this load case showed minimal levels (<15 mm)

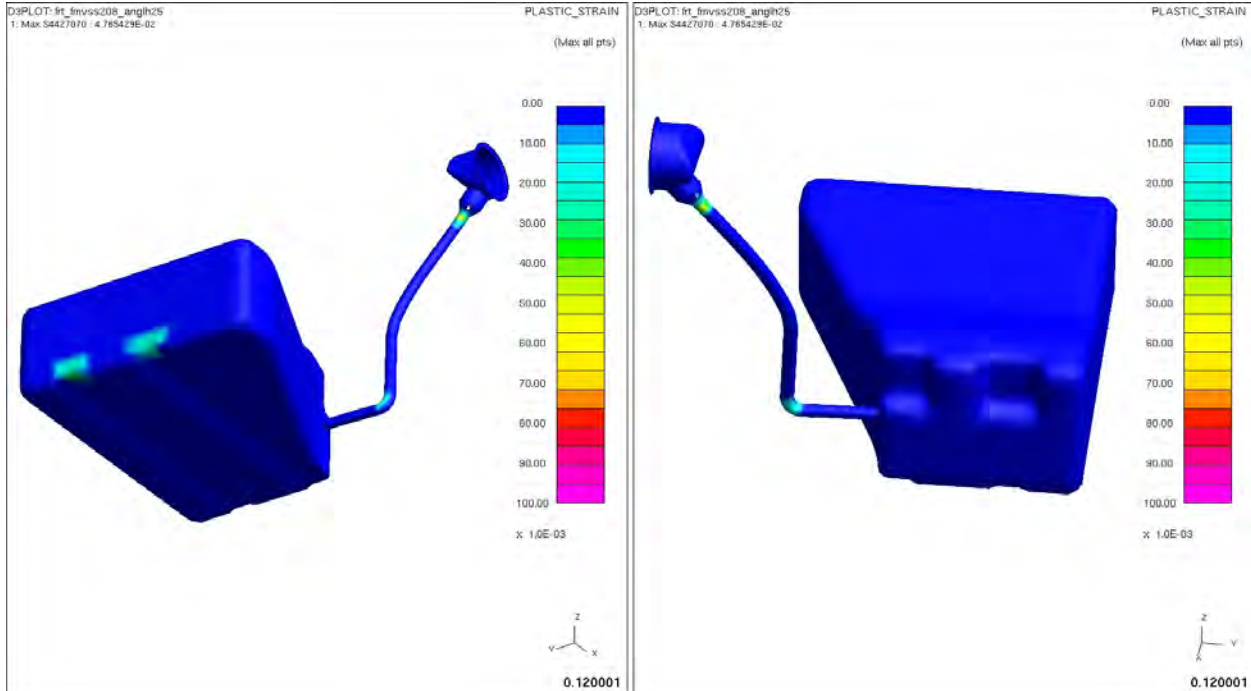

Figure 4.3.3.g: Fuel tank plastic strain after 30°, left-side frontal impact

The predicted fuel tank plastic strains are below the expected material failure level, < 6 percent.

The main energy absorbing body structure components are the front bumper, left bumper bracket, left main rails, the front end module (FEM) left shotgun inner and left front shock tower as shown below.

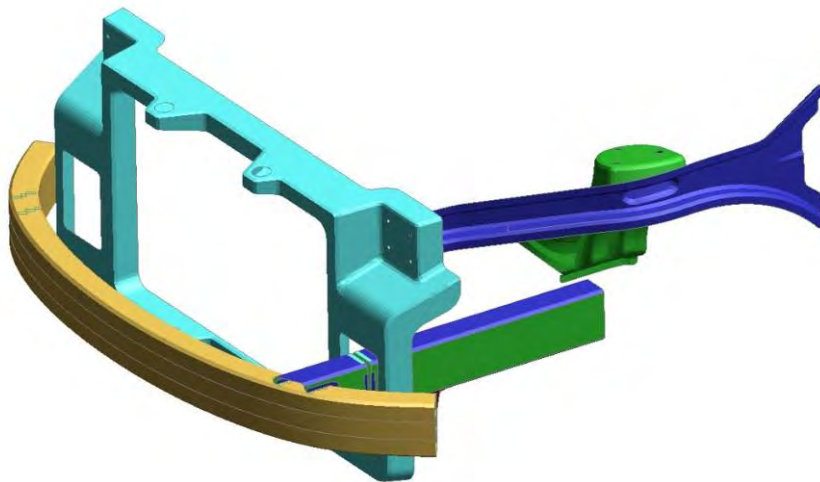

Figure 4.3.3.h: Main energy absorbing body structure for fuel tank plastic strain after 30°, left-side frontal impact

The energy balance for this analysis showed no issues with the model as no energy was lost or created.

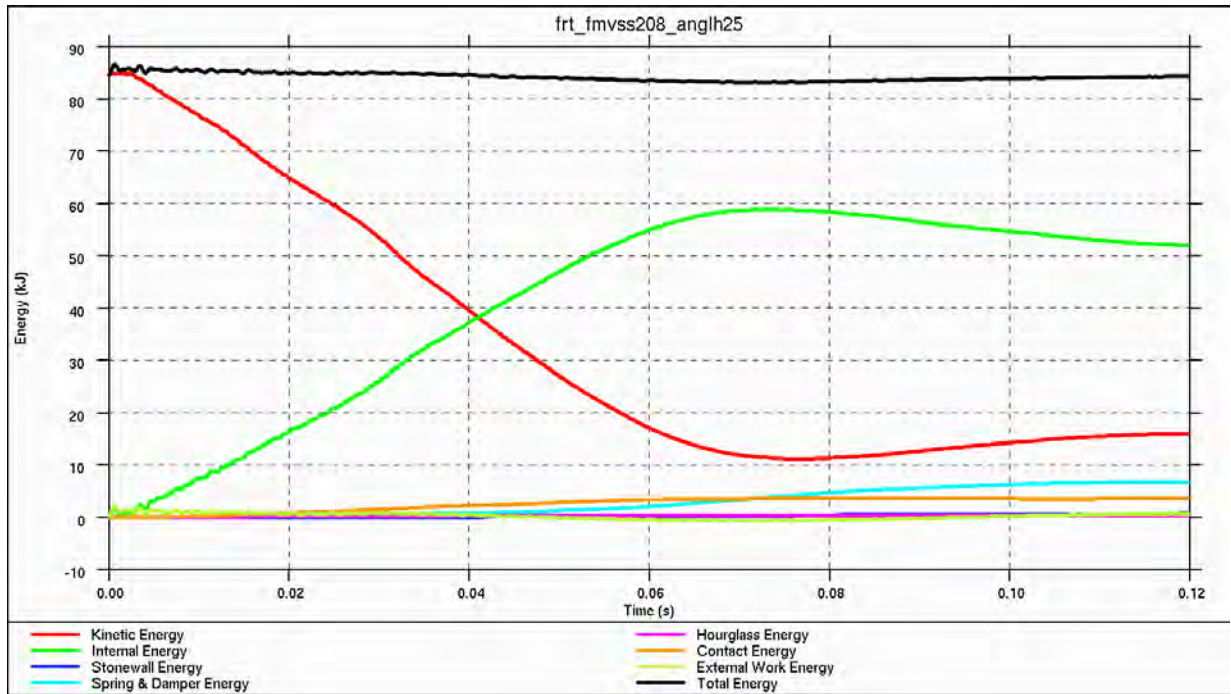

Figure 4.3.3.i: Energy balance for 30°, left-side frontal impact

4.3.4. FMVSS208: 25mph 30° Flat Barrier – Right Side

In this test the right-side time to zero velocity was actually found to be longer than the left side: 0.092 s vs. 0.076 s for the left side impact. The analysis predicts acceptable performance from the body structure with very little noticeable deformation at the front door aperture.

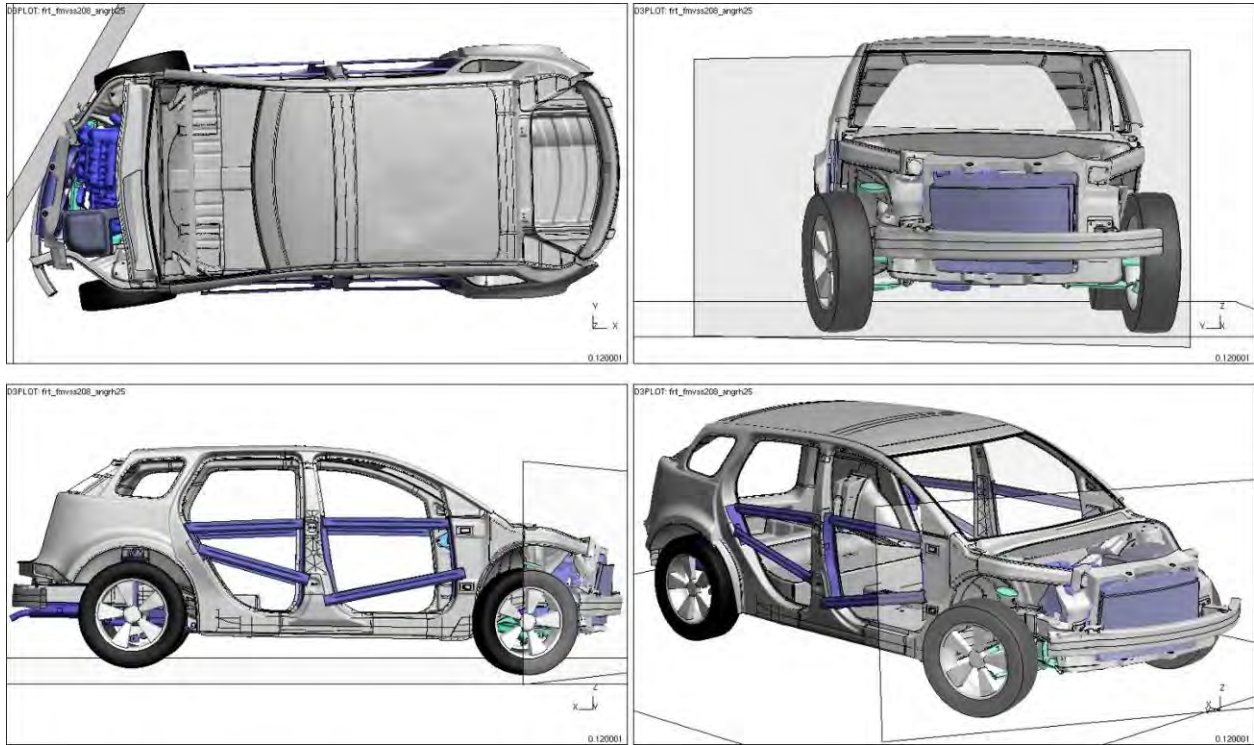

Figure 4.3.4.a: Vehicle deformation (t=0.12 s) after 30°, right-side frontal impact

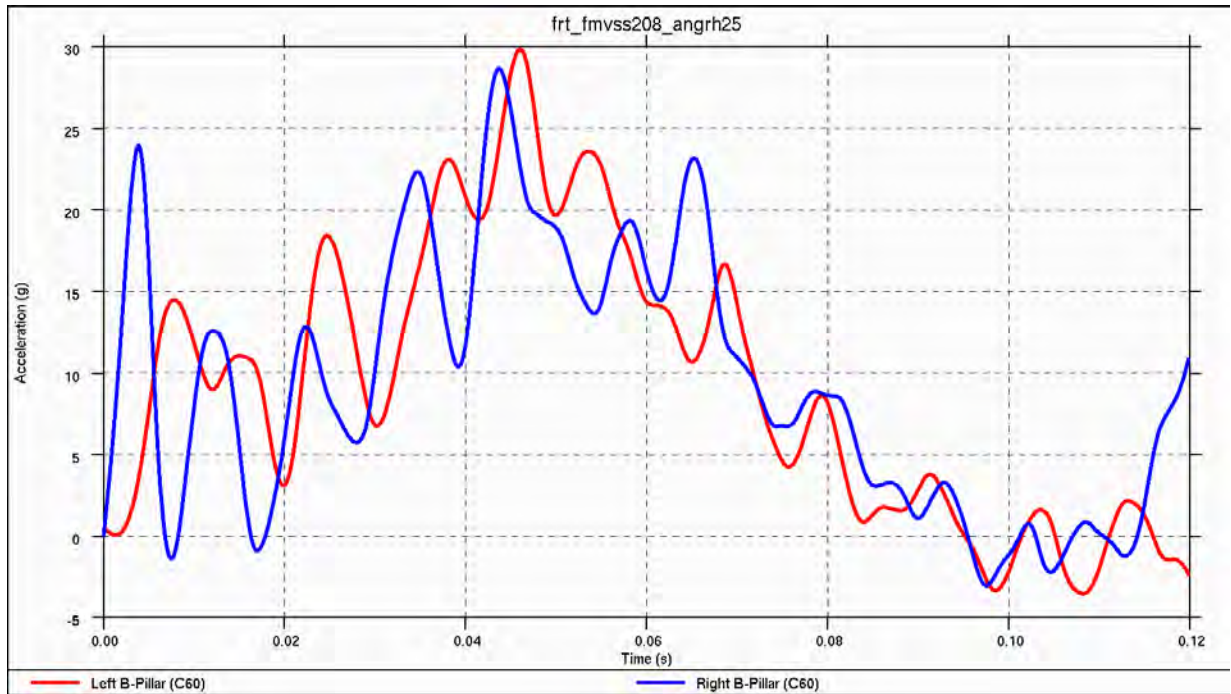

Figure 4.3.4.b: Vehicle acceleration pulse during 30°, right-side frontal impact

The left and right acceleration pulses (red and blue respectively) are different due to the angled barrier primarily loading the right side of the vehicle and also due to the asymmetry of the engine. Averaging both left and right side accelerations gives the average pulse shown below.

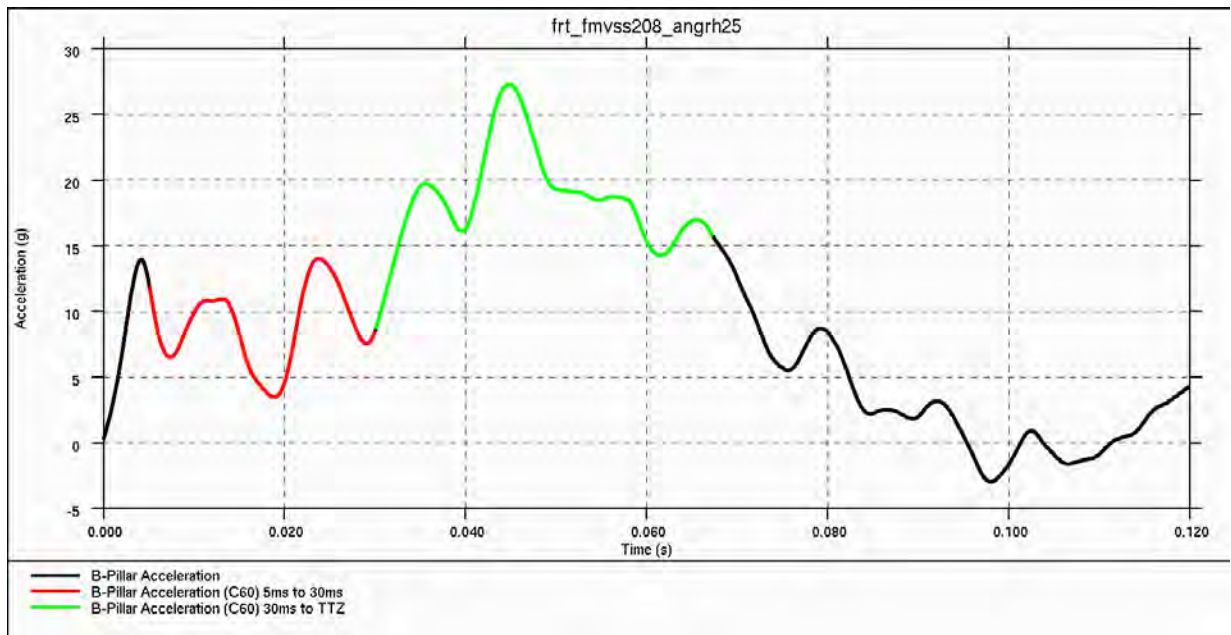

Figure 4.3.4.c: Vehicle average acceleration pulse during 30°, right-side frontal impact

The overall average acceleration pulse is just below 14 G. The average initial acceleration (5 to 30 ms) was 8.9 G. The average acceleration from 30 ms to TTZ was 9.5 G. These are less than for the left side impact and are a result of the longer TTZ.

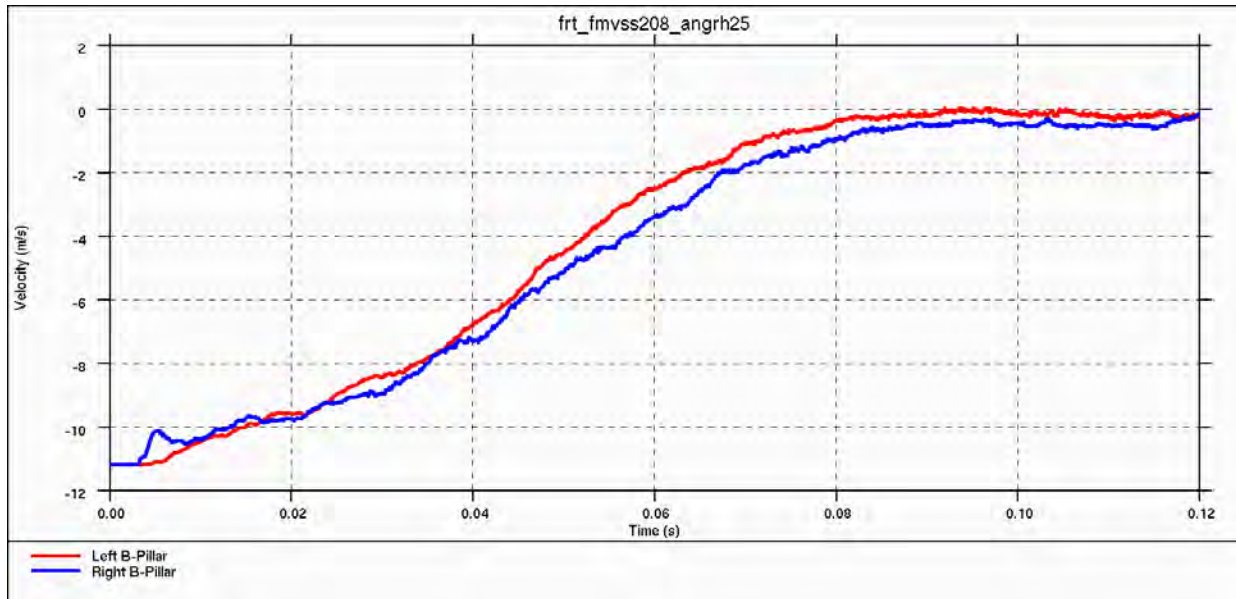

Figure 4.3.4.d: Vehicle velocity during 30°, right-side frontal impact
- time to zero velocity (TTZ) = 92 ms

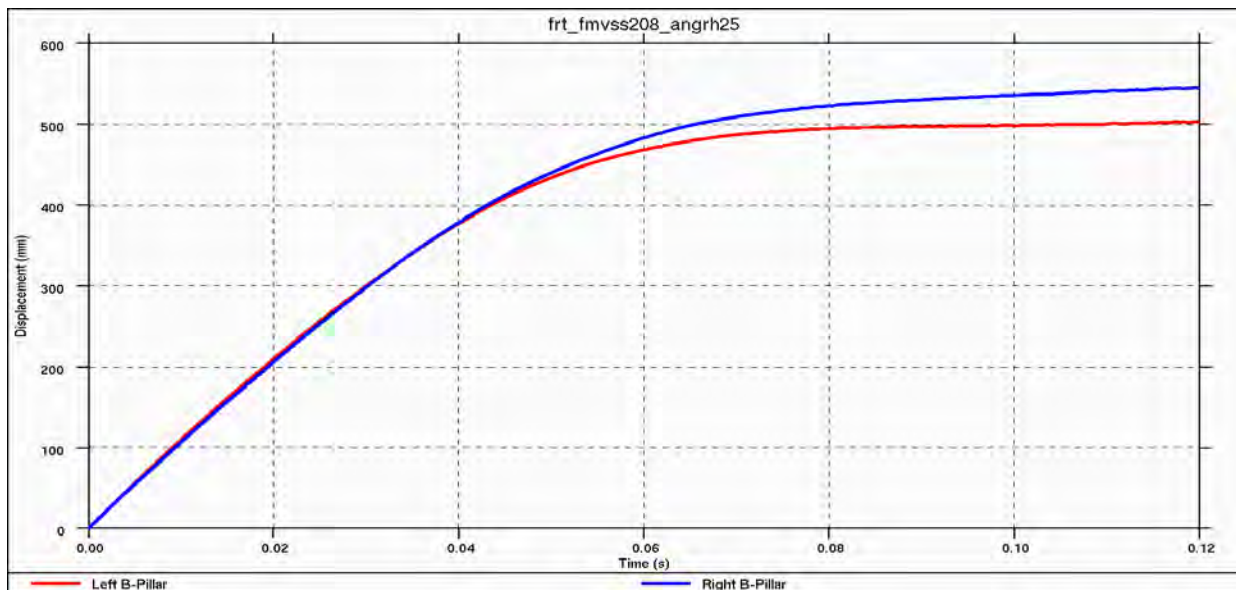

Figure 4.3.4.e: Vehicle displacement during 30°, right-side frontal impact - maximum dynamic crush 524 mm

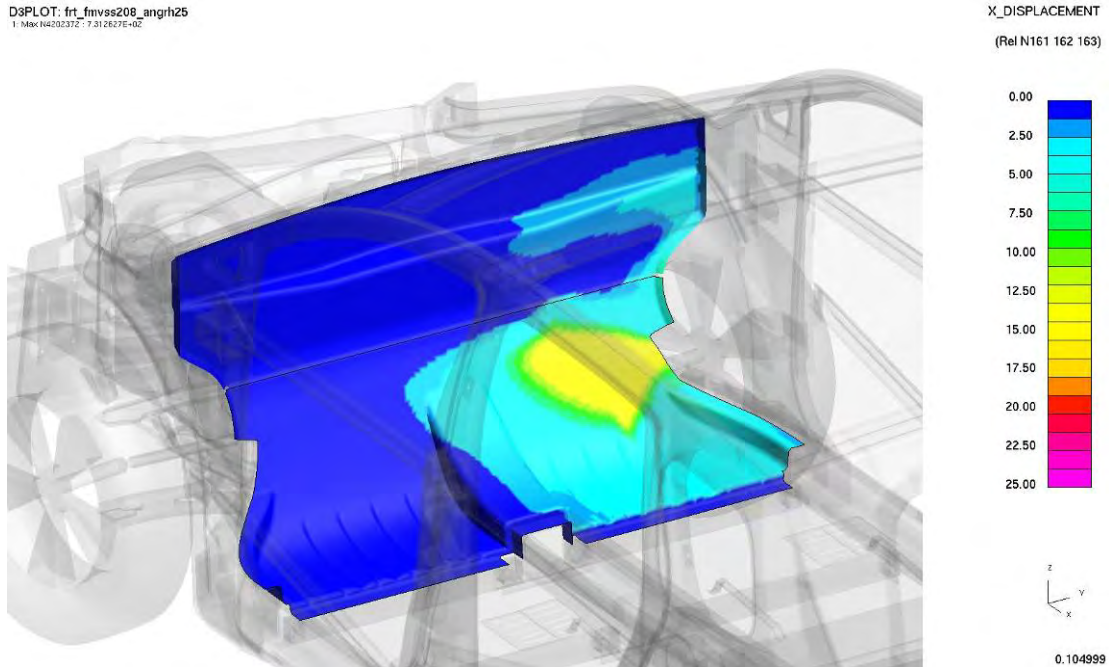

Figure 4.3.4.f: CAE dash intrusion analysis after 30°, right-side frontal impact

The intrusion into the dash for this load case were very similar to the left-side impact predicting minimal levels (<15 mm)

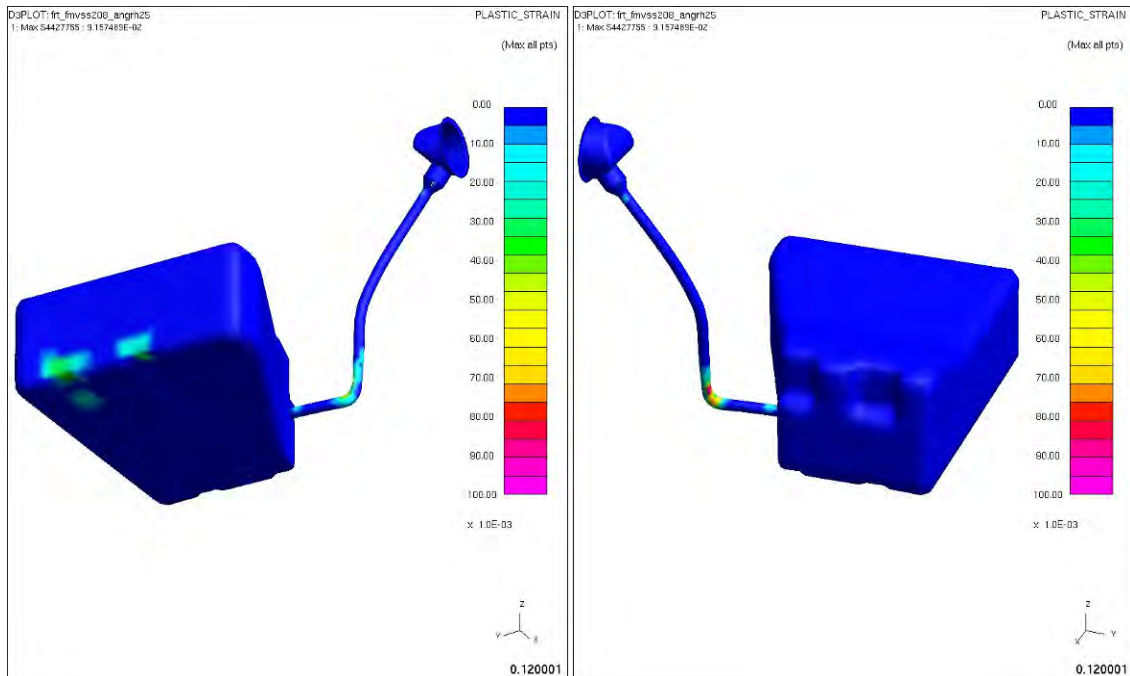

Figure 4.3.4.g: Fuel tank plastic strains after 30°, right-side frontal impact

The predicted fuel tank plastic strains are below the expected material failure level, < 4 percent.

The main energy absorbing components for the right side impact include the front bumper, right bumper bracket, right main rails, front end module (FEM), and dash reinforcement, but not the shotgun or shock tower. This is due to the load path through the engine because of the ancillary mounting locations. This load path through the engine is not present for the left side. As a result of the loading through the engine, contact to the dash cross-member occurs sooner, transmitting more load.

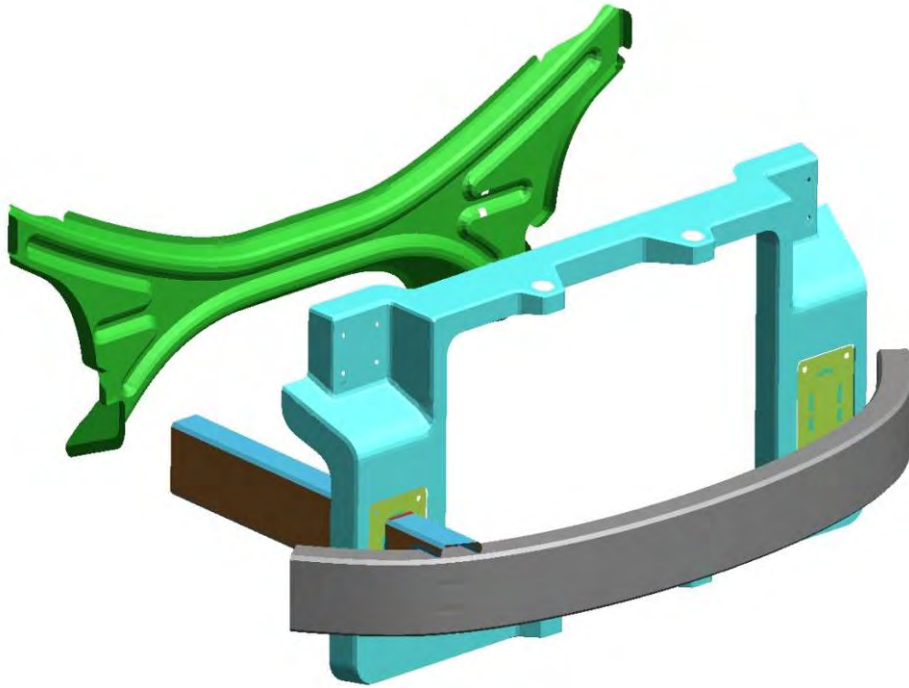

Figure 4.3.4.h: Main energy absorbing body structure for 30°, right-side frontal impact

The corresponding energy balance verified the analysis, showing that the total energy level was maintained.

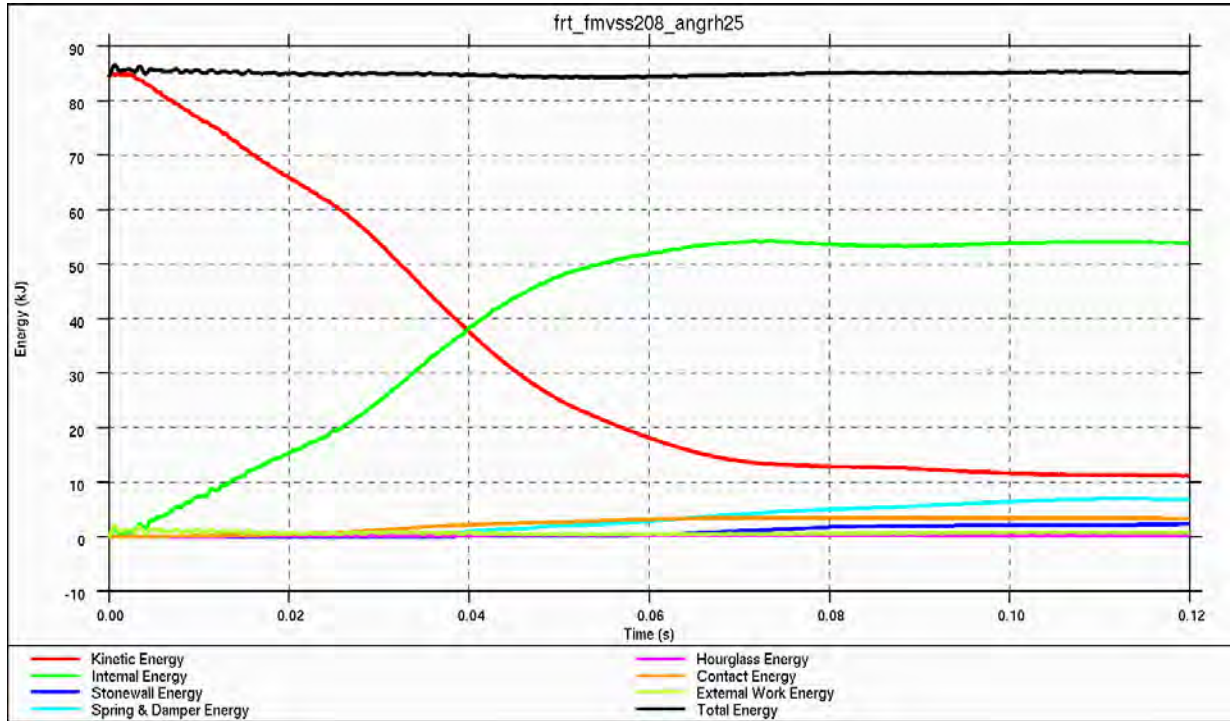

Figure 4.3.4.i: Energy balance for 30°, right-side frontal impact

4.3.5. FMVSS 210: Seatbelt Anchorages

This test is a worst-case analysis as it tests just two of the four floor seatbelt mounting locations. The front mounting locations are part of the seat assembly, which was beyond the scope of this project. Even in this worst case scenario the mounting locations showed acceptable deformation levels.

4.3.5.1. Front

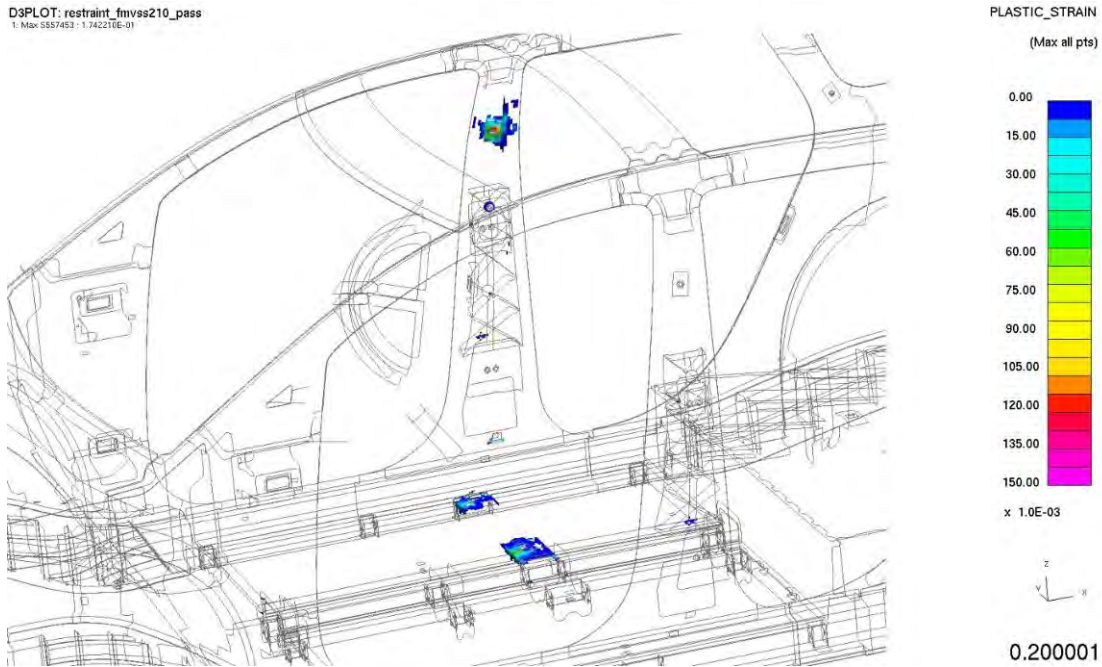
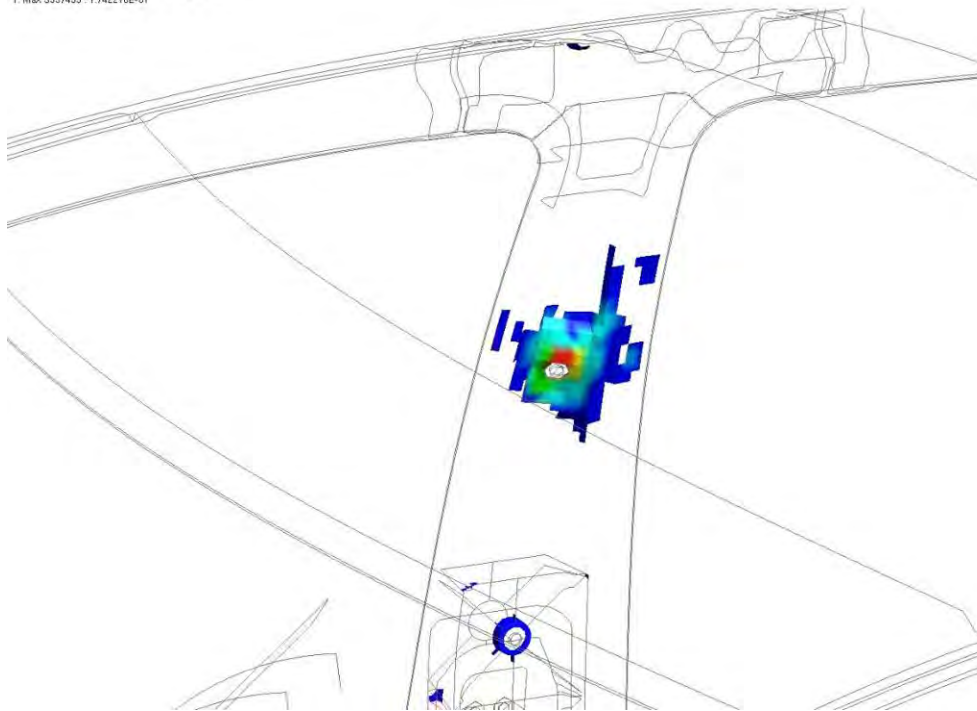

Figure 4.3.5.1.a: Seatbelt anchorage plastic strains (@ 0.2 s)

D3PLOT: restraint_fmvs210_pass
1: Max:557453 - 1.742210E-01



PLASTIC_STRAIN
(Max all pts)



x 1.0E-03



0.200001

Figure 4.3.5.1.b: Upper seatbelt anchorage plastic strain (@ 0.2 s)

D3PLOT: restraint_fmvs210_pass
1: Max:557453 - 1.742210E-01

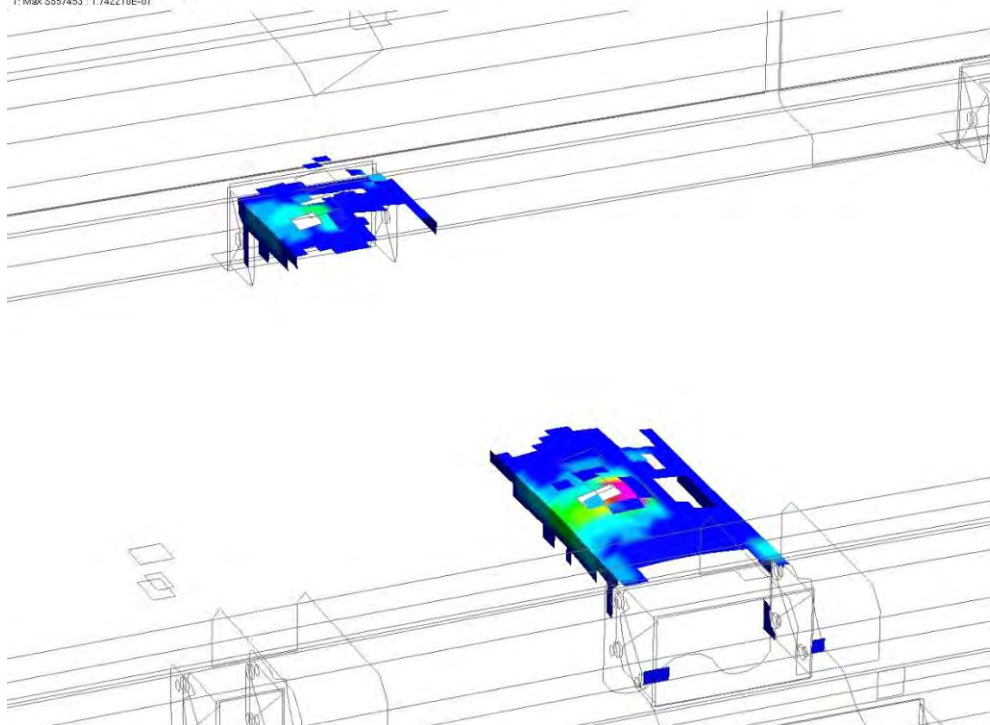

PLASTIC_STRAIN
(Max all pts)

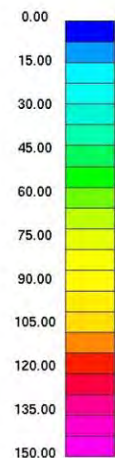

x 1.0E-03



0.200001

Figure 4.3.5.1.c: Lower seatbelt anchorage plastic strain (@ 0.2 s)

4.3.5.2. Rear

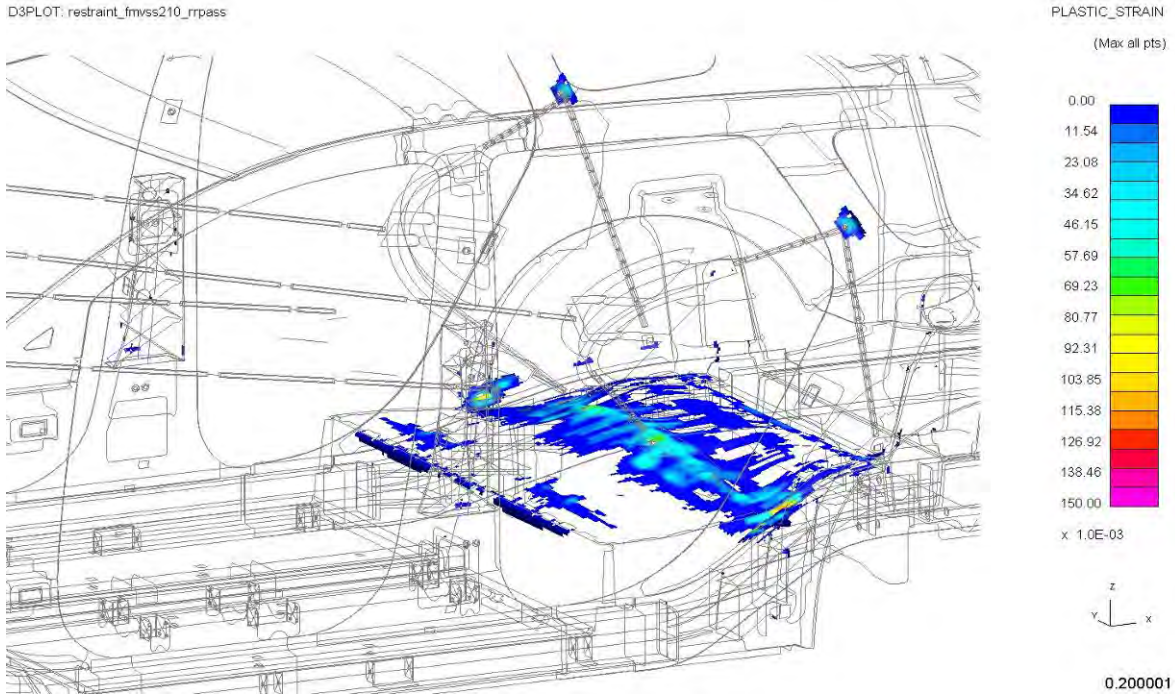

Figure 4.3.5.2.a: Rear seatbelt anchorage plastic strain (@ 0.2 s)

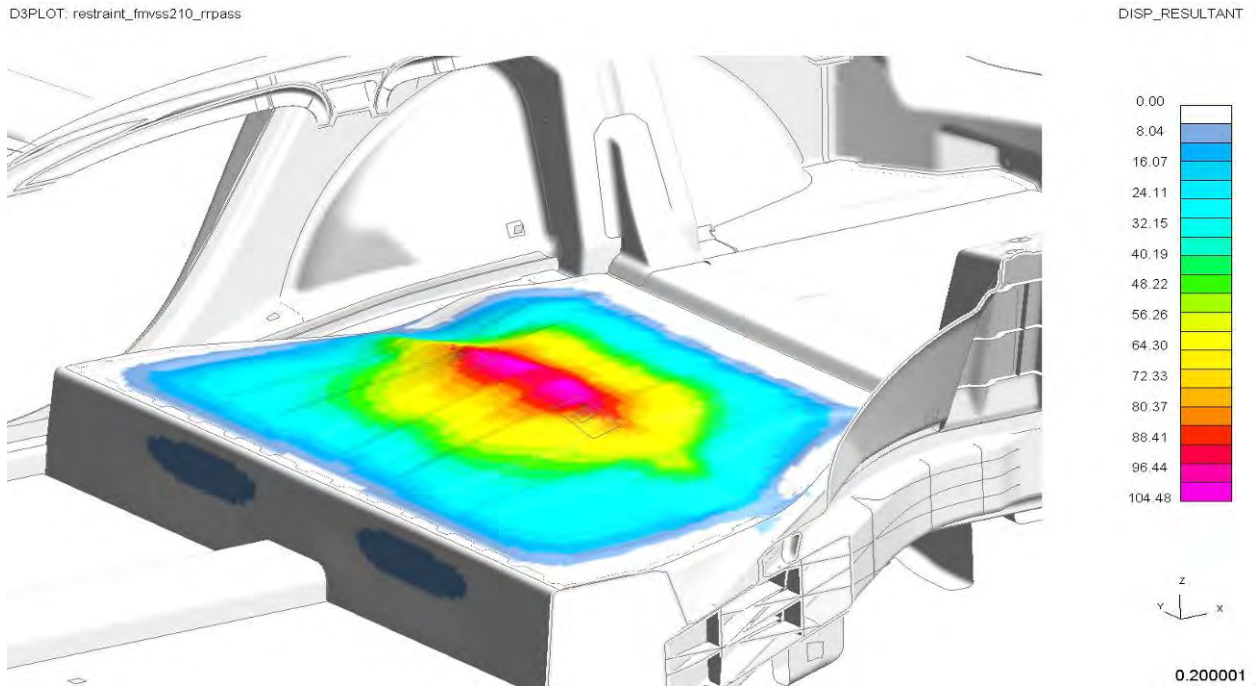

Figure 4.3.5.2.b: Displacement at lower seatbelt anchorages (@0.2 s)

4.3.6. FMVSS 213: Child Restraint Systems

The child restraint system was tested using a worst-case situation with a 30-kg child representation to account for various unknowns. The highest mass child representation specified by NHTSA is a 21-kg mass, representative of a 10-year old child. The CAE analyses below show the Phase 2 HD passes these preliminary tests as the anchorage held the load case.

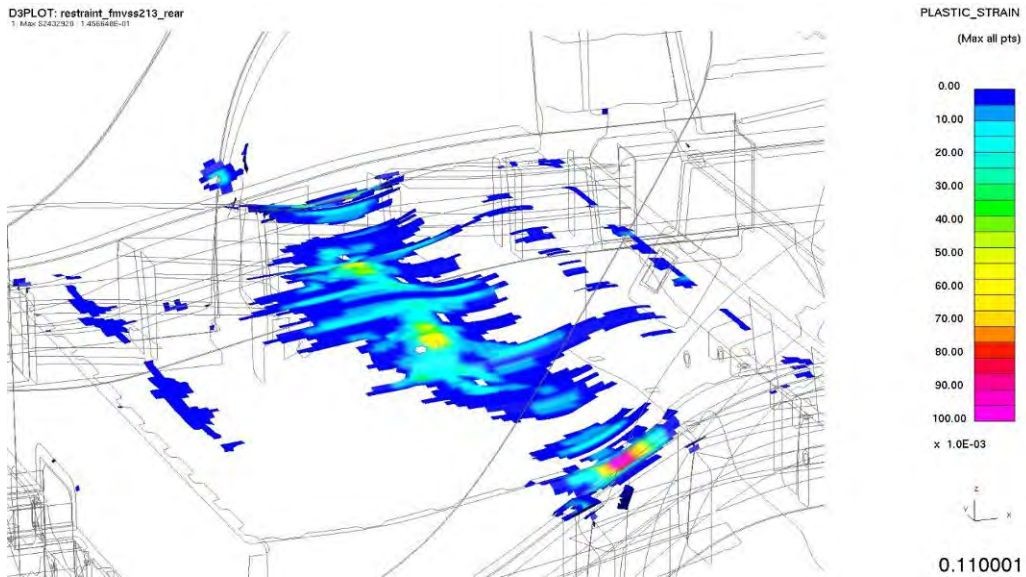

Figure 4.3.6.a: Child-restraint, lower anchorage plastic strain

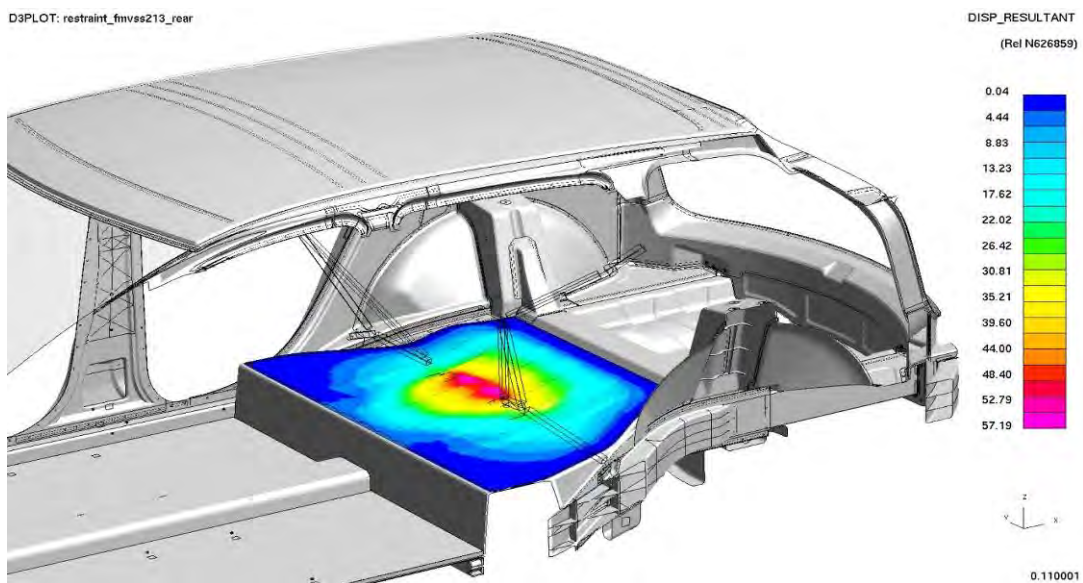

Figure 4.3.6.b: Child-restraint seat pan displacements

4.3.7. FMVSS 214: 33.5 mph Side Impact – Crabbed Barrier

This is designed to test the intrusion levels in the event of a side impact. Full doors (closures) are typically included in this test, but were beyond the scope of this project. This test was performed with just the BIW structure – B-pillar and side impact beams. A maximum allowable intrusion level was set at 300 mm as this is the standard distance between the door panel and seat in a full interior. The Phase 2 HD BIW met this standard with a maximum intrusion of around 115 mm without doors. The results of the CAE analysis for this test are shown below.

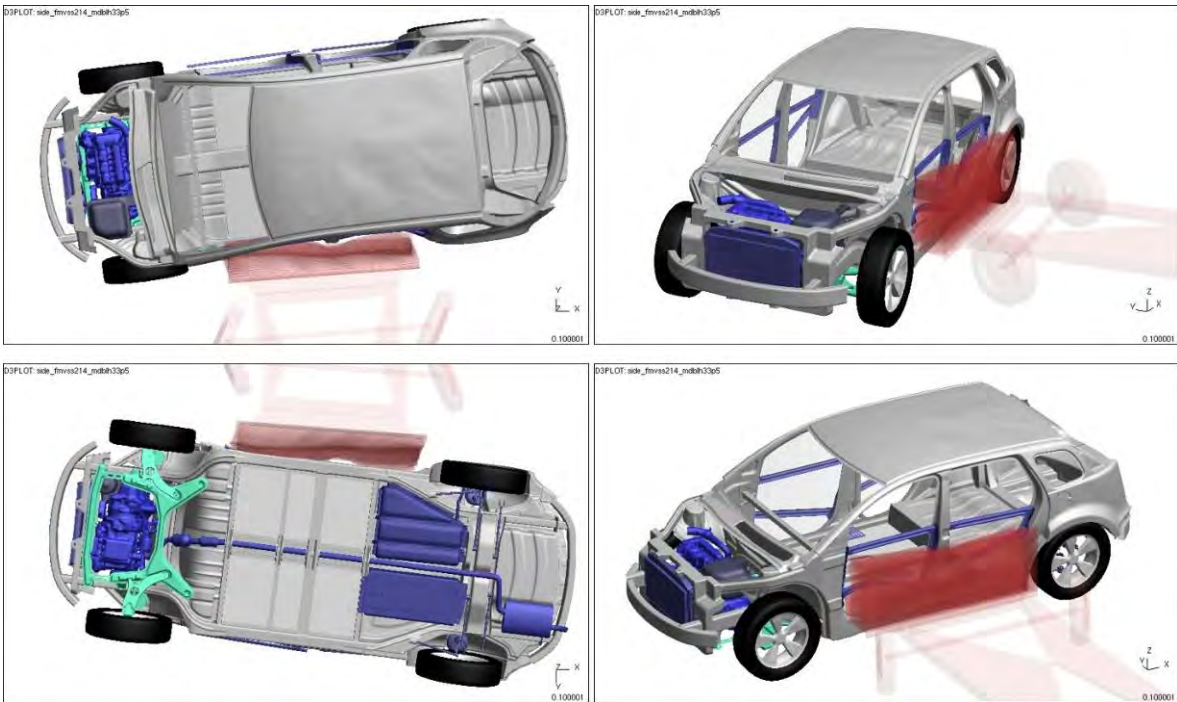

Figure 4.3.7.a: Vehicle deformation (0.1 s) after crabbed barrier impact

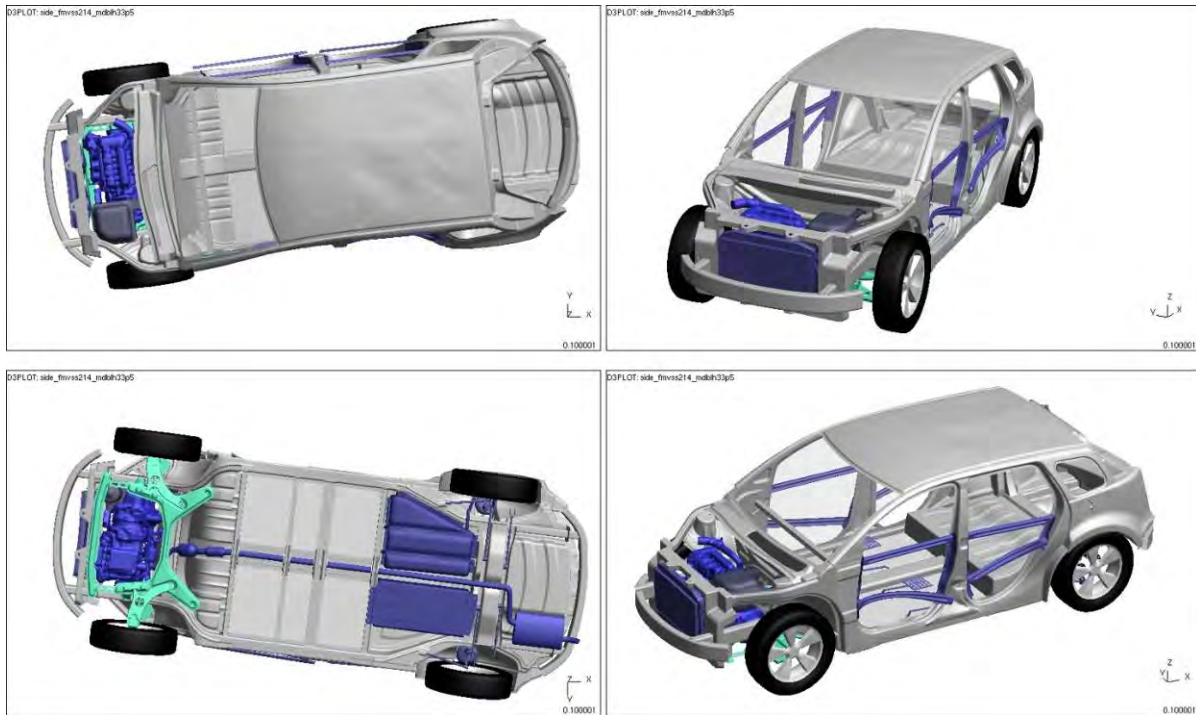

Figure 4.3.7.b: Vehicle deformation (barrier not shown) after crabbed barrier impact

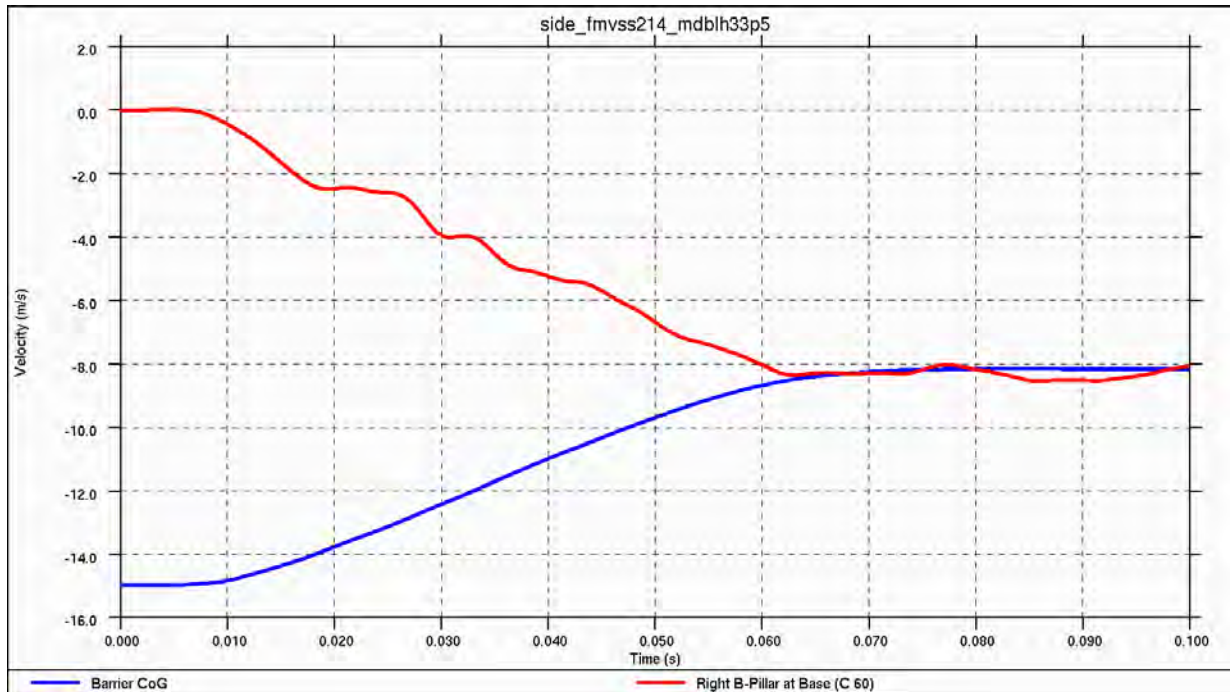

Figure 4.3.7.c: Global vehicle and barrier velocities for crabbed barrier impact

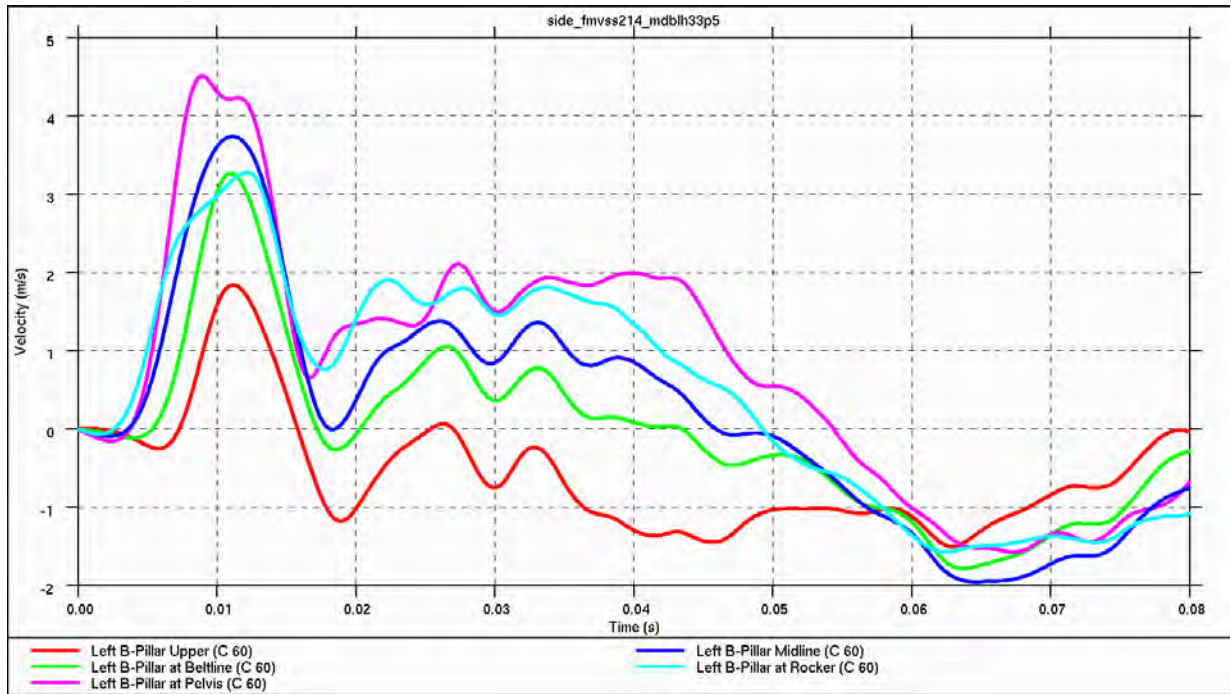

Figure 4.3.7.d: Relative intrusion velocities (B-pillar) during crabbed barrier impact

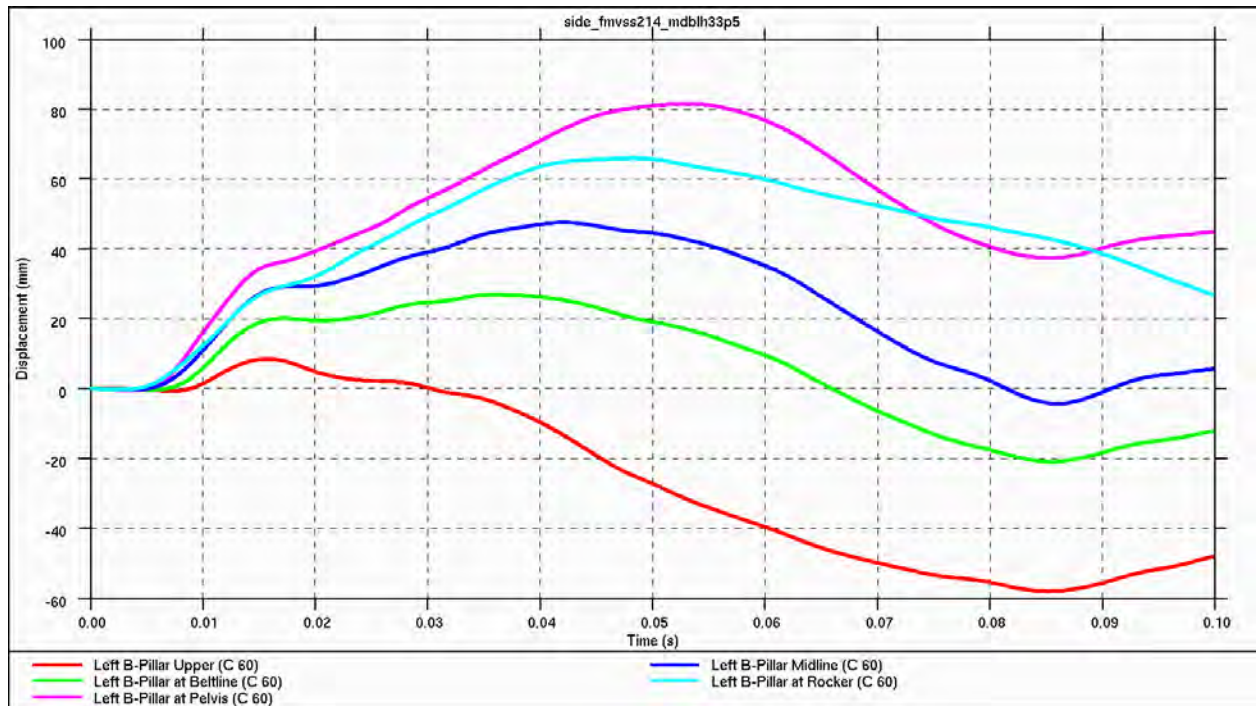

Figure 4.3.7.e: Relative intrusion displacements (B-pillar) during crabbed barrier impact

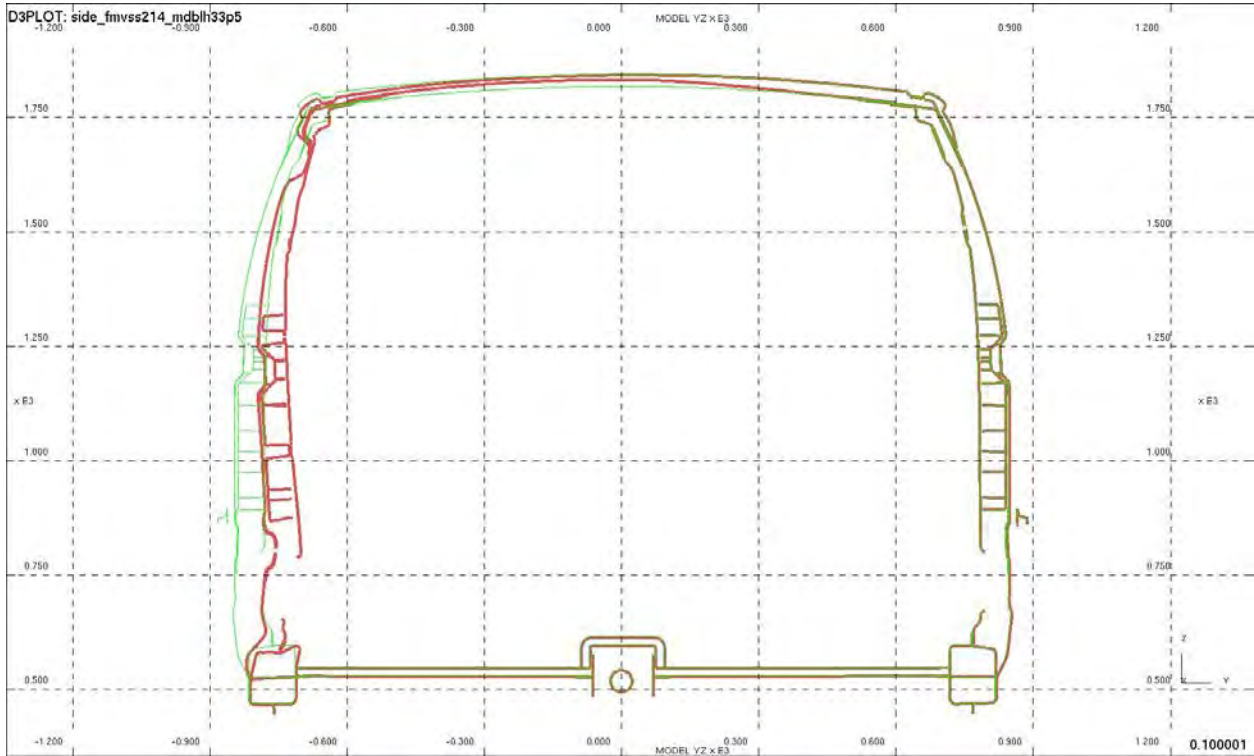

Figure 4.3.7.f: B-pillar intrusion profile after crabbed barrier impact, $x=2842$

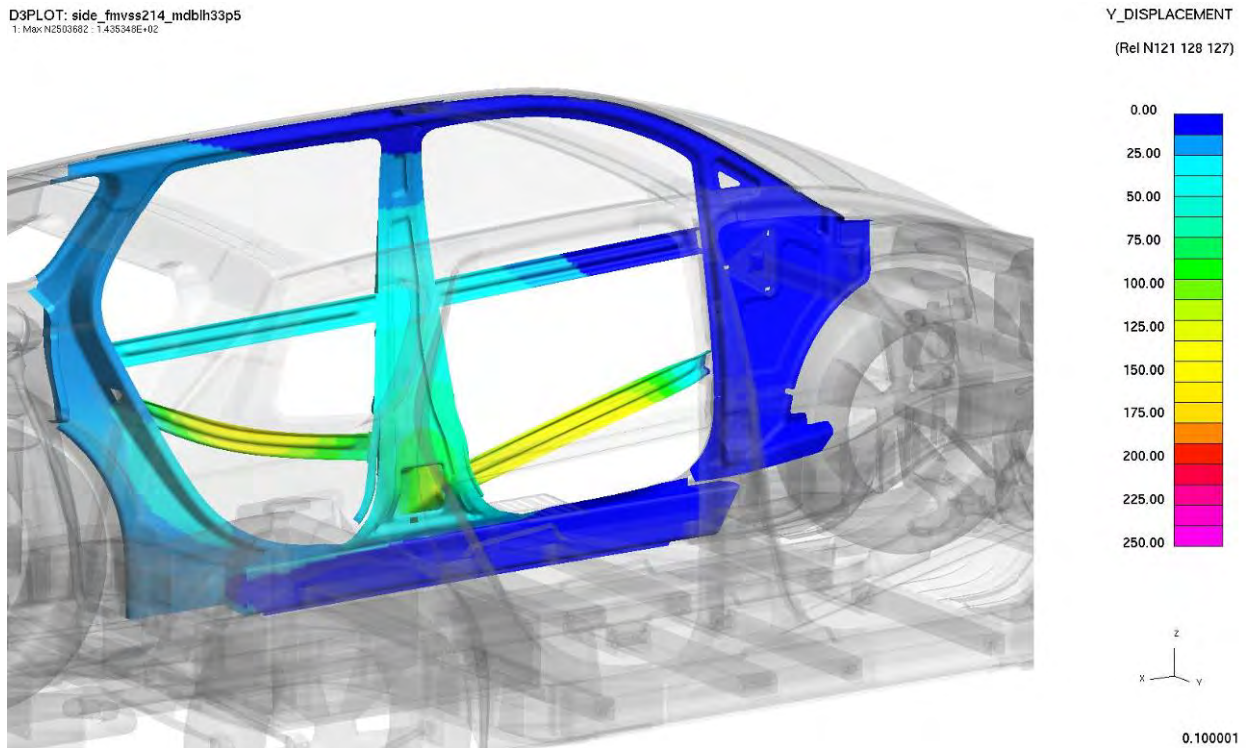

Figure 4.3.7.g: Intrusion levels after crabbed barrier impact on struck side

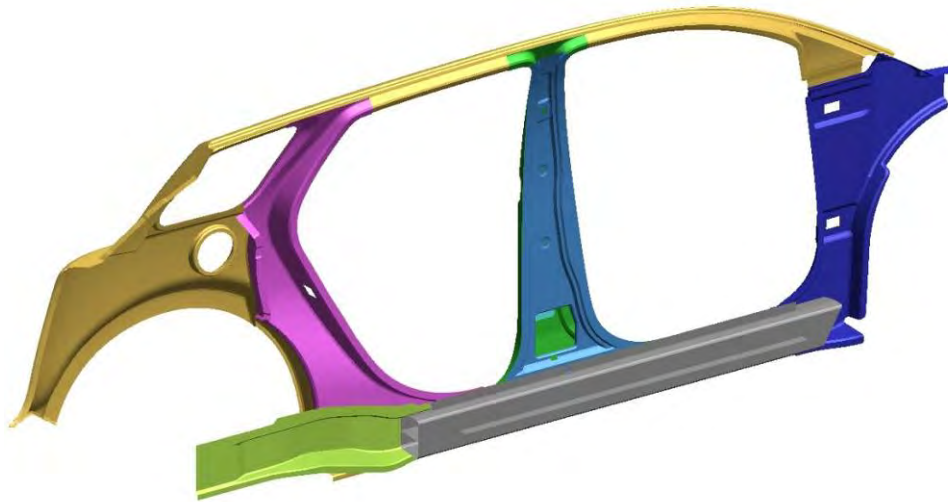

Figure 4.3.7.h: Main energy absorbing body structure parts for crabbed barrier impact

This energy balance verified the crabbed-barrier-impact model as no energy was created or destroyed during the simulation.

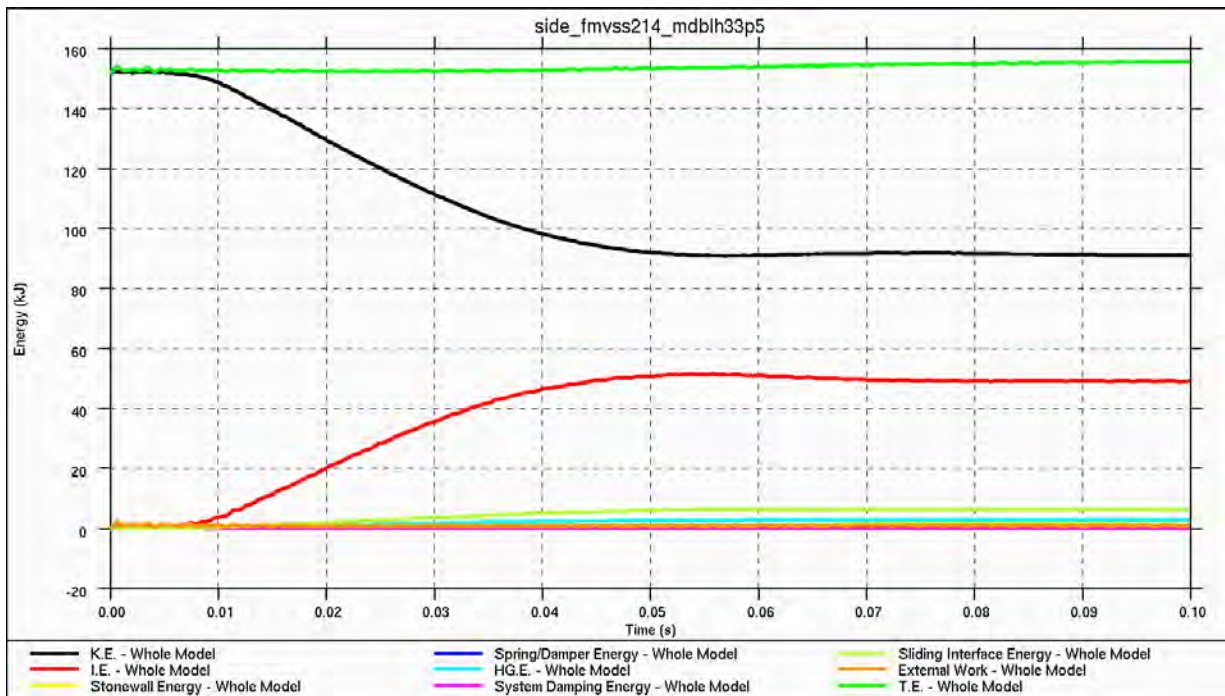

Figure 4.3.7.i: Energy balance for crabbed barrier impact

4.3.8. FMVSS 214: 20 mph 75° Side Pole Impact – Front (5th percentile Female)

This test is usually performed with full closures and measures occupant acceleration levels, which were beyond the project scope. Intrusion levels were used to gauge occupant protection again, and with a maximum intrusion of around 250 mm, the Phase 2 HD BIW is below the maximum allowable of 300 mm.

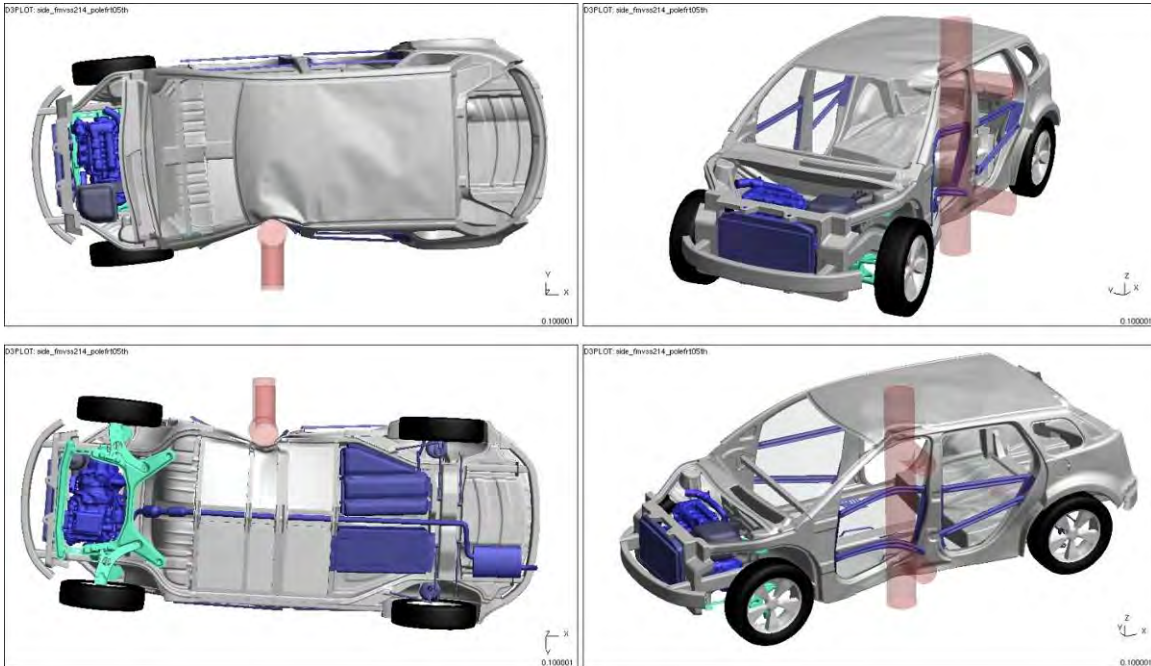

Figure 4.3.8.a: Vehicle deformation (0.1 s) after 75°, side, pole impact – 5th percentile female

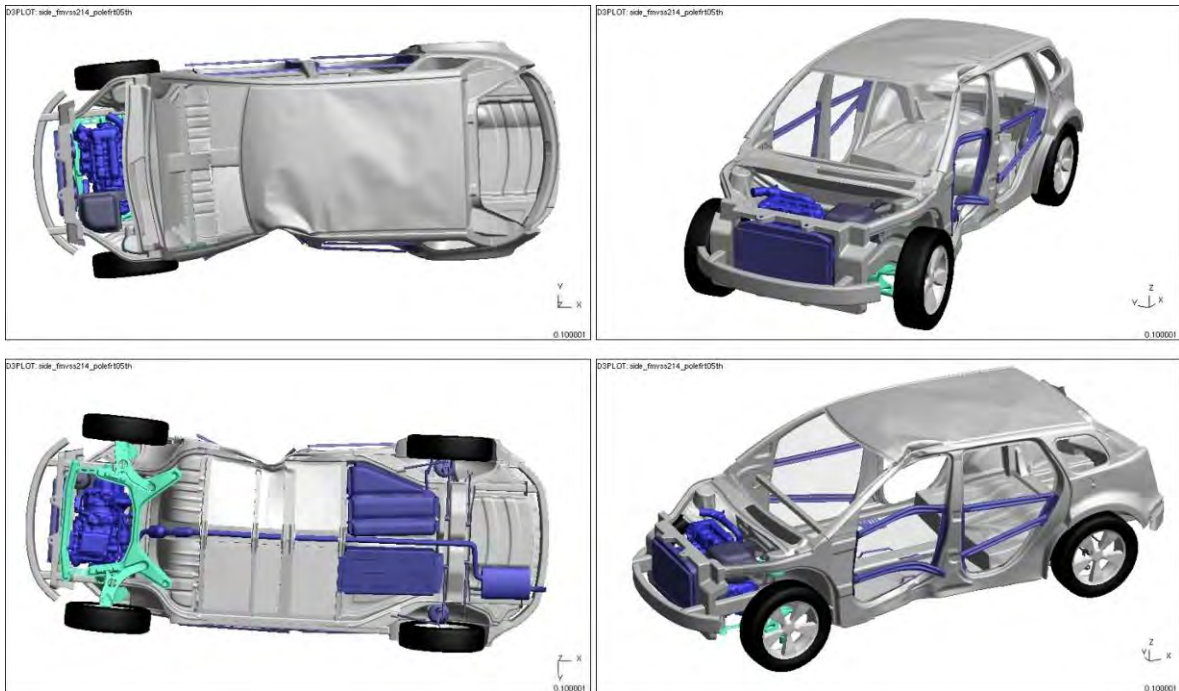

Figure 4.3.8.b: Vehicle deformation after 75°, side, pole impact (pole blanked) – 5th percentile female

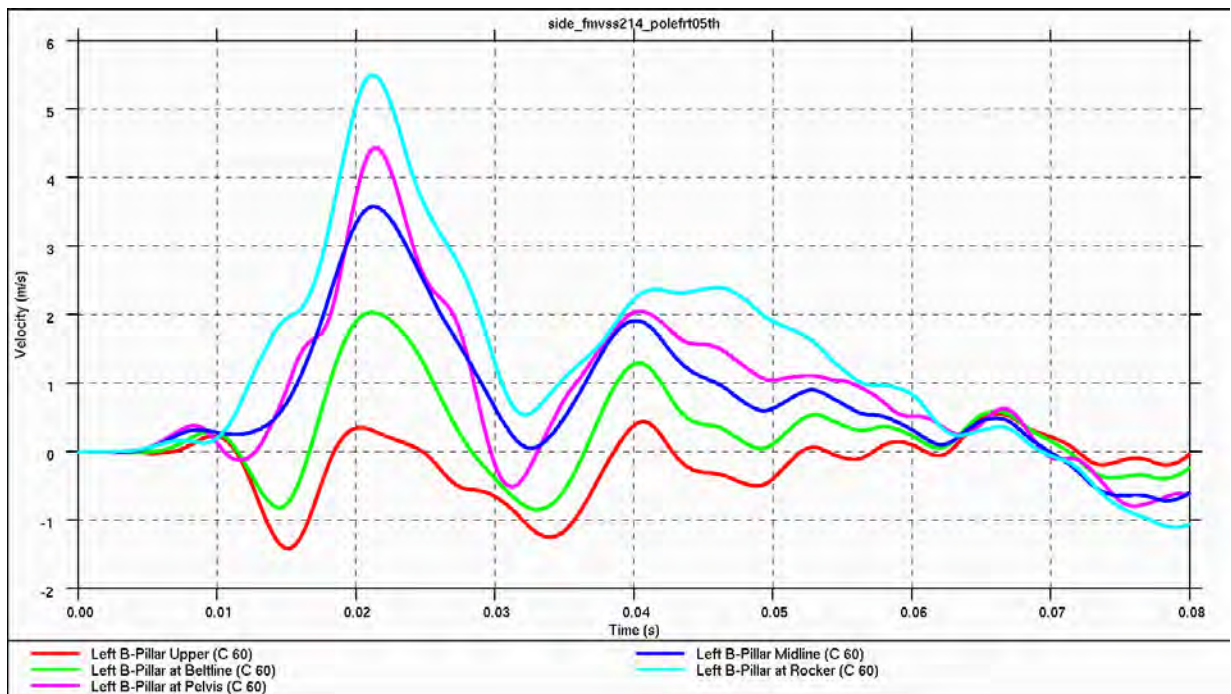

Figure 4.3.8.c: Relative intrusion velocities during 75°, side, pole impact (B-pillar) – 5th percentile female

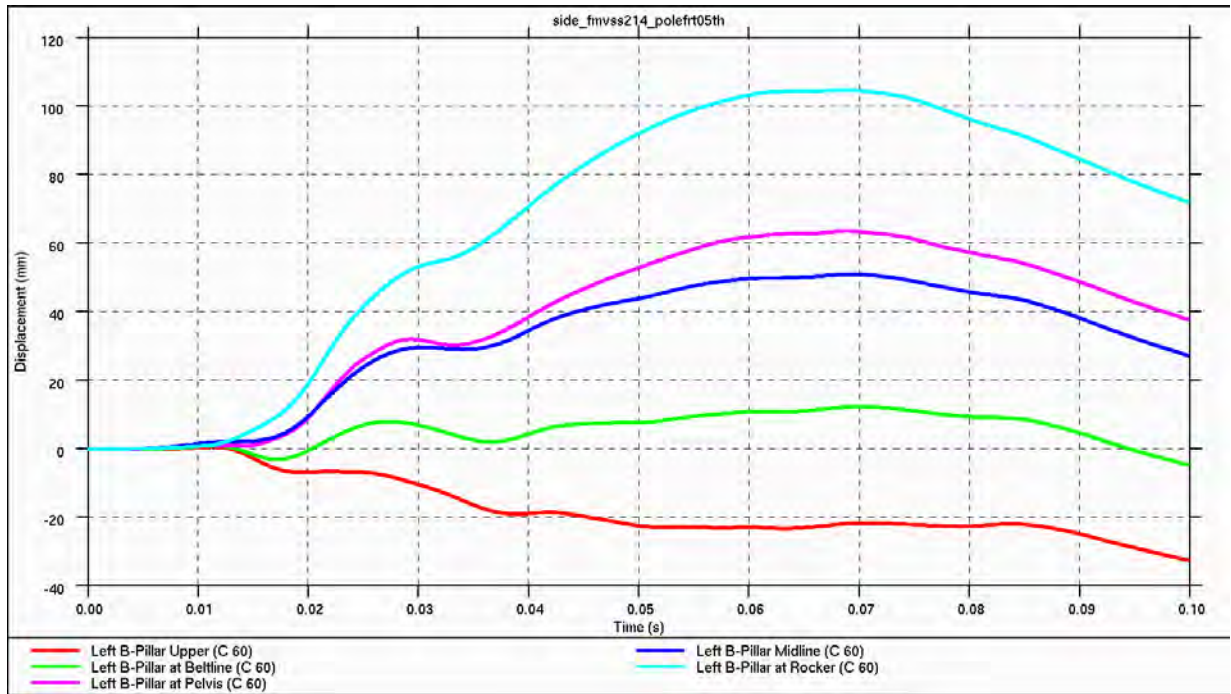

Figure 4.3.8.d: Relative intrusion displacements during 75°, side, pole impact (B-pillar) – 5th percentile female

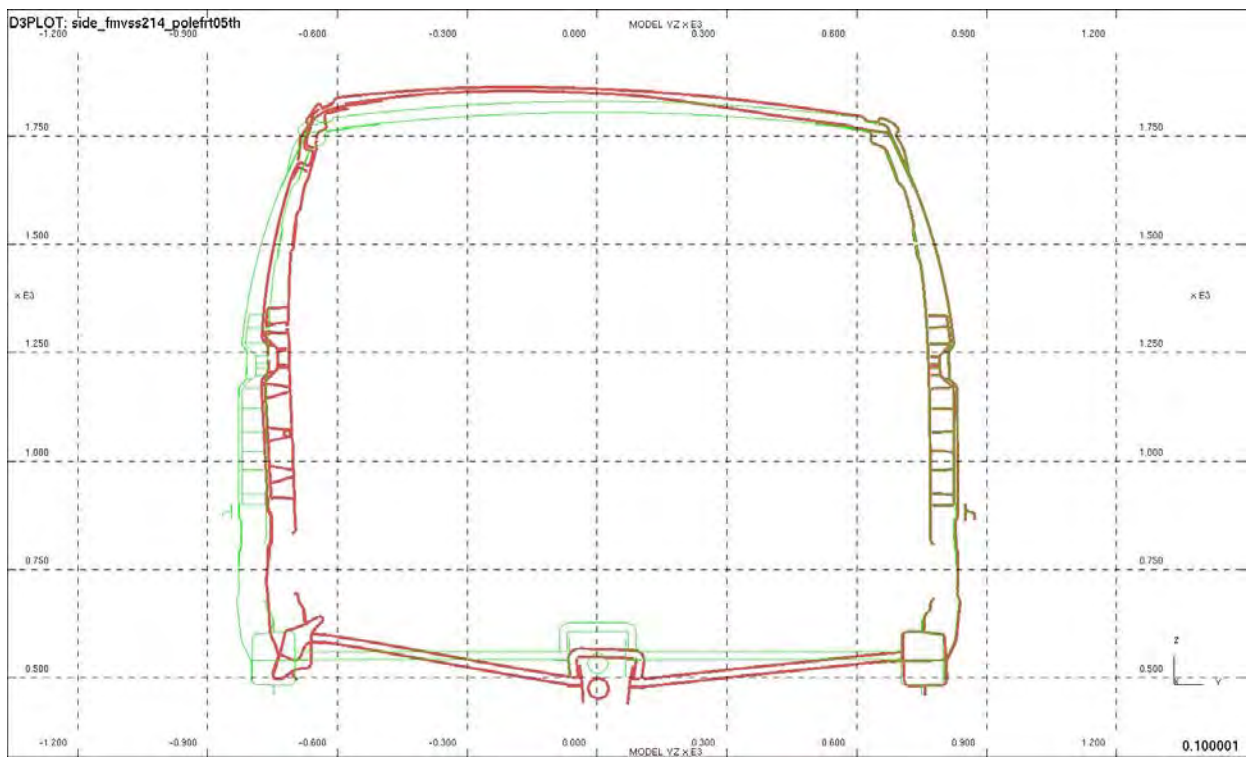

Figure 4.3.8.e: Section through B-pillar after 75°, side, pole impact, x= 2842 – 5th percentile female

D3PLOT: side_fmvs214_polefrt05th
1: Max: N2503775 : 2.483336E+02

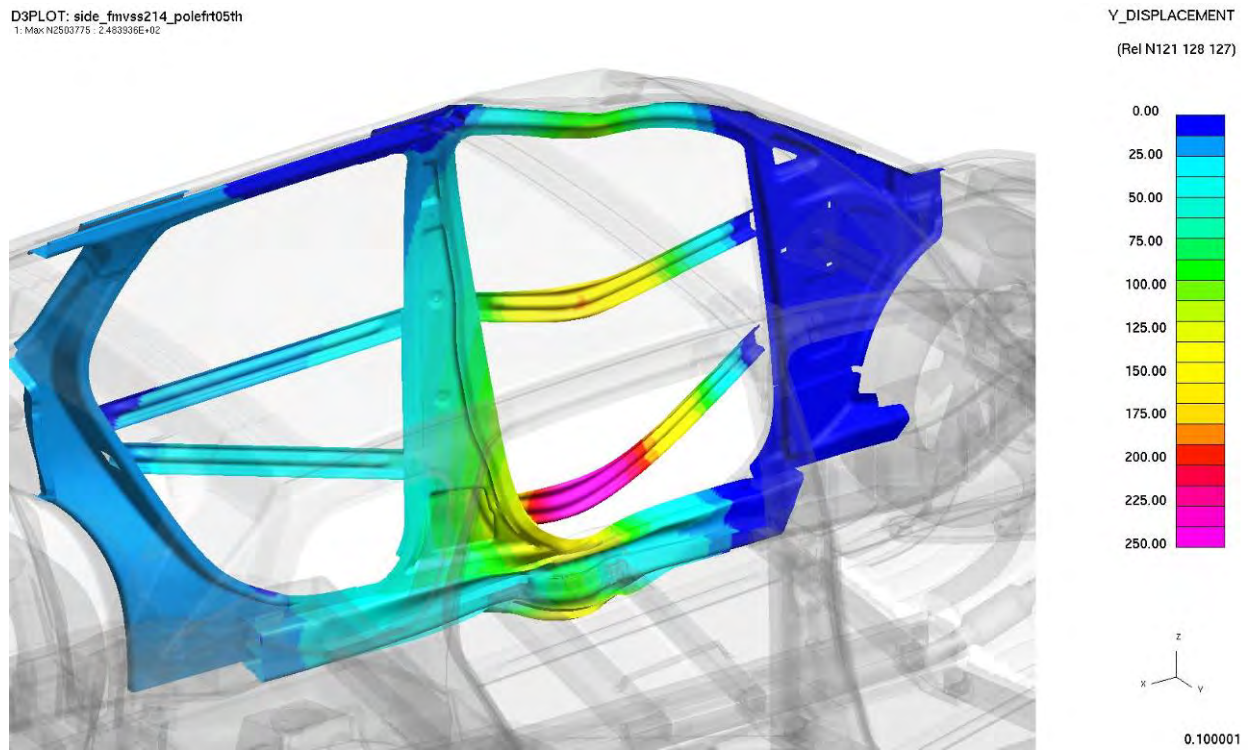

Figure 4.3.8.f: Intrusion levels after 75°, side, pole impact on struck side – 5th percentile female

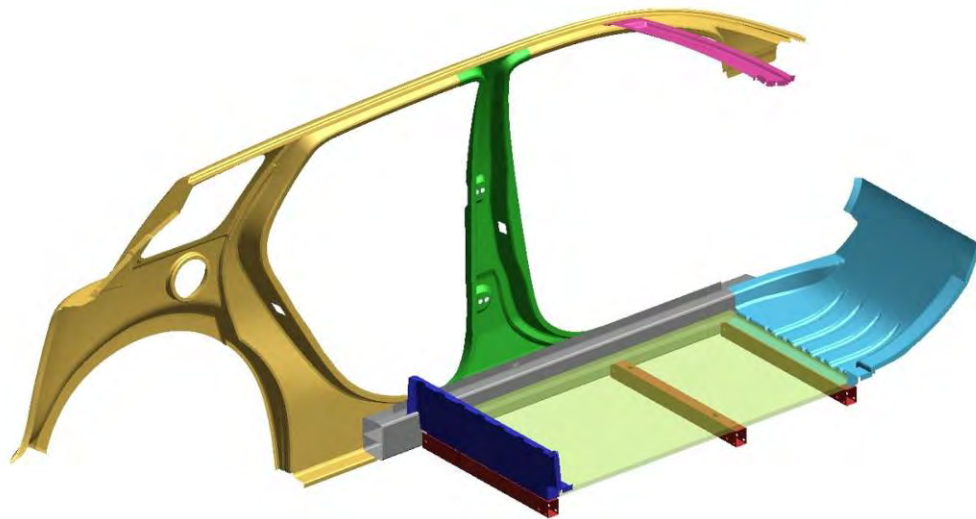

Figure 4.3.8.g: Main energy absorbing body structure for 75°, side, pole impact – 5th percentile female

This energy balance verified the analysis because the total energy remained constant through the simulation.

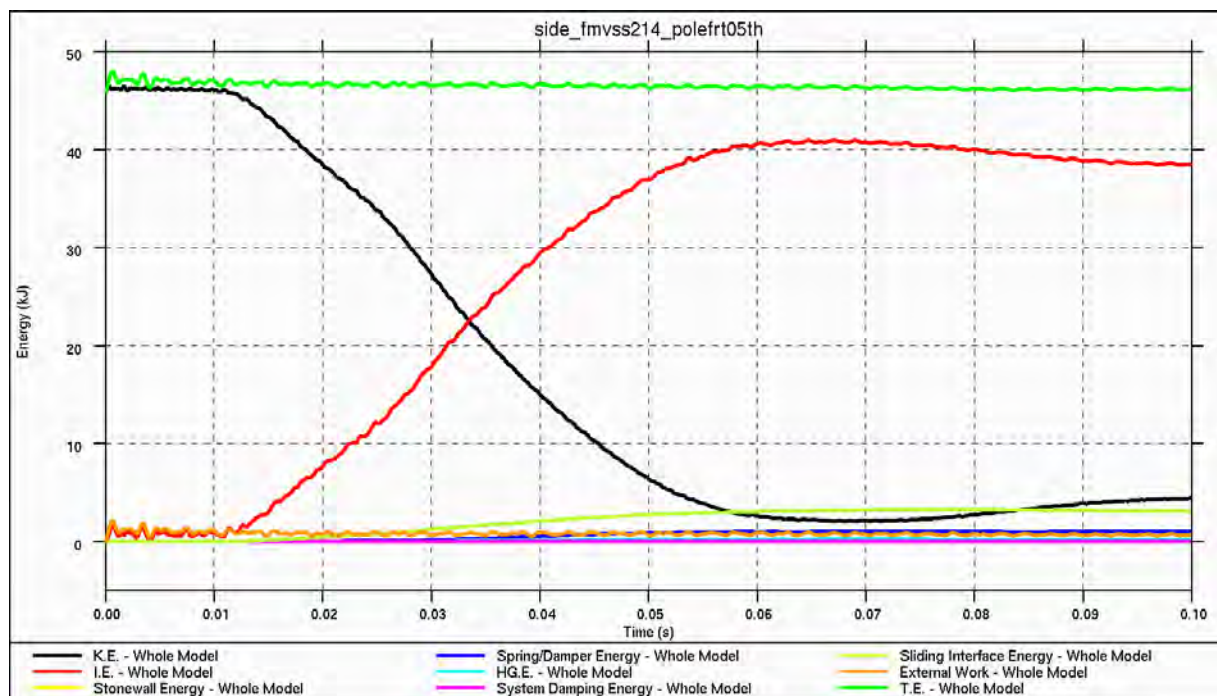

Figure 4.3.8.h: Energy balance for 75°, side, pole impact – 5th percentile female

4.3.9. FMVSS 214: 20 mph 75° Side Pole Impact – Front (50th percentile Male)

Using a 50th percentile male instead of a 5th percentile female moves the pole impact location, but reveals the Phase 2 HD BIW still has acceptable structural performance. A maximum intrusion level of around 225 mm was observed, which is below the 300 mm maximum allowable.

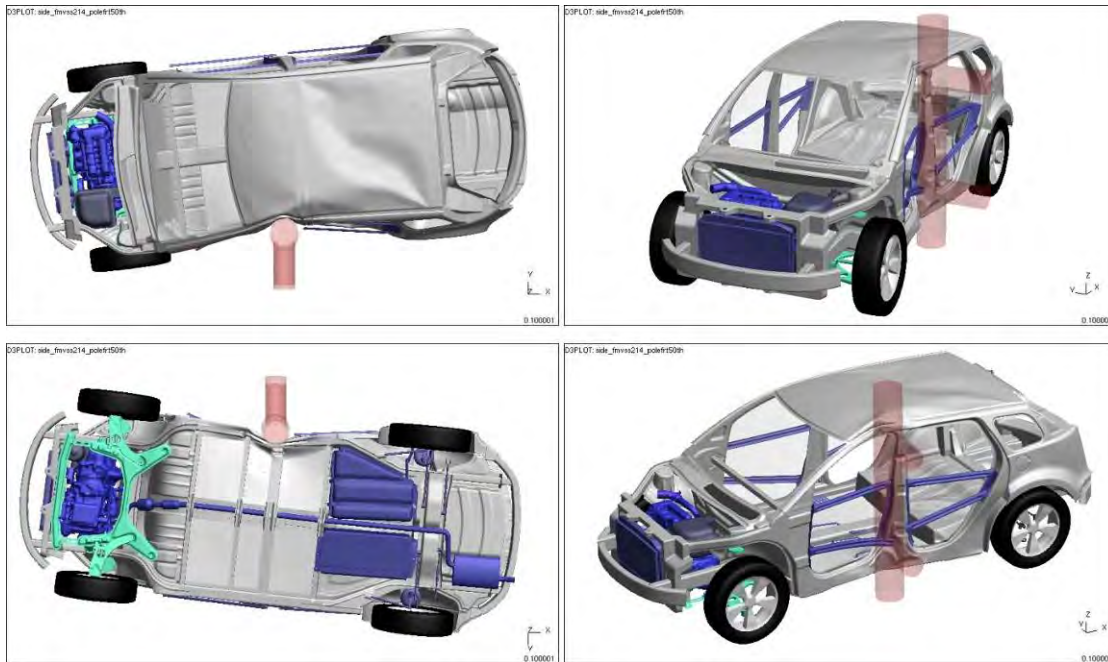

Figure 4.3.9.a: Vehicle deformation (0.1 s) after 75°, side, pole impact – 50th percentile male

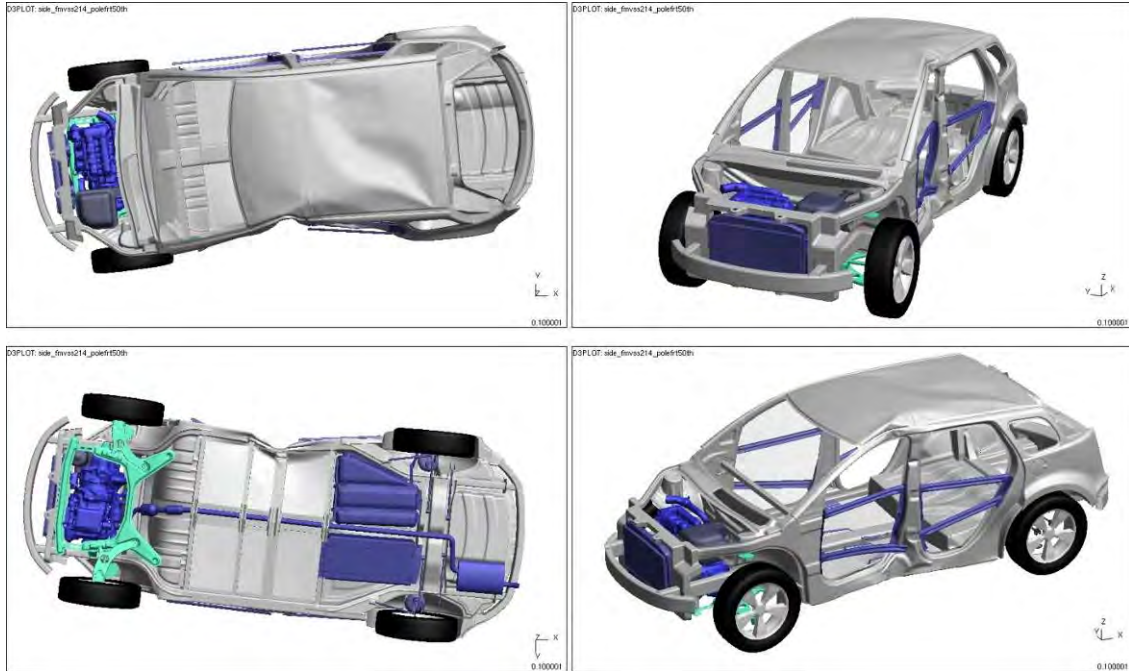

Figure 4.3.9.b: Vehicle deformation after 75°, side, pole impact (pole blanked) – 50th percentile male

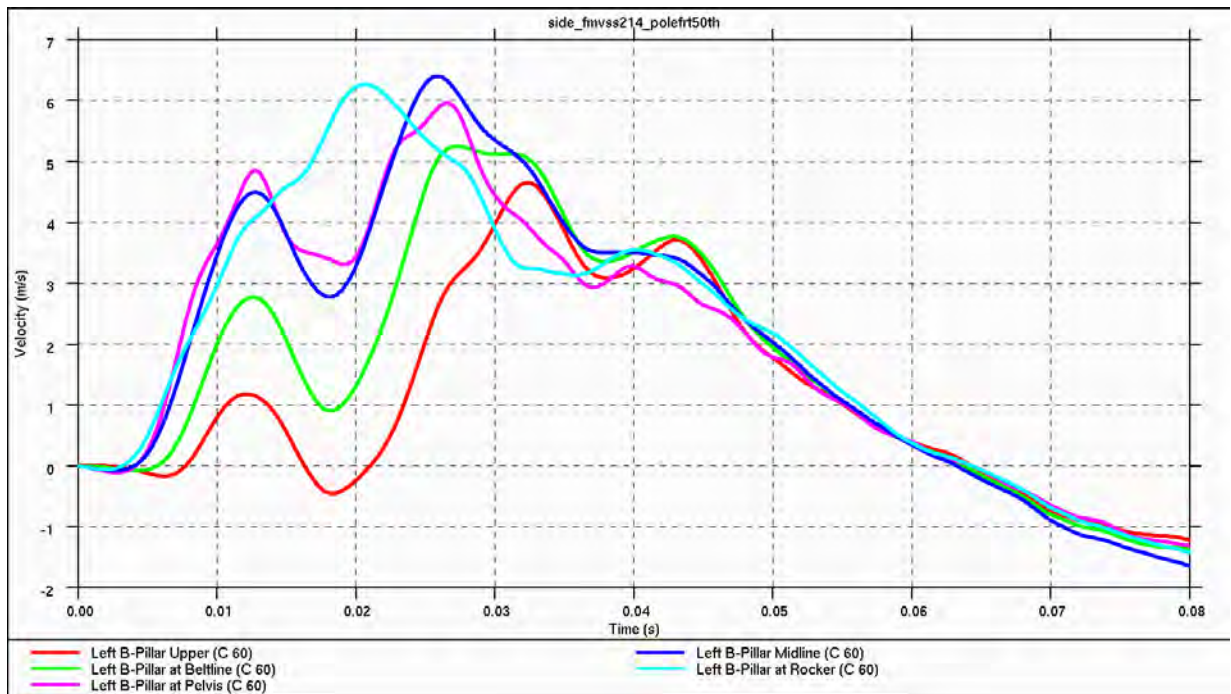

Figure 4.3.9.c: Relative intrusion velocities during 75°, side, pole impact (B-pillar) – 50th percentile male

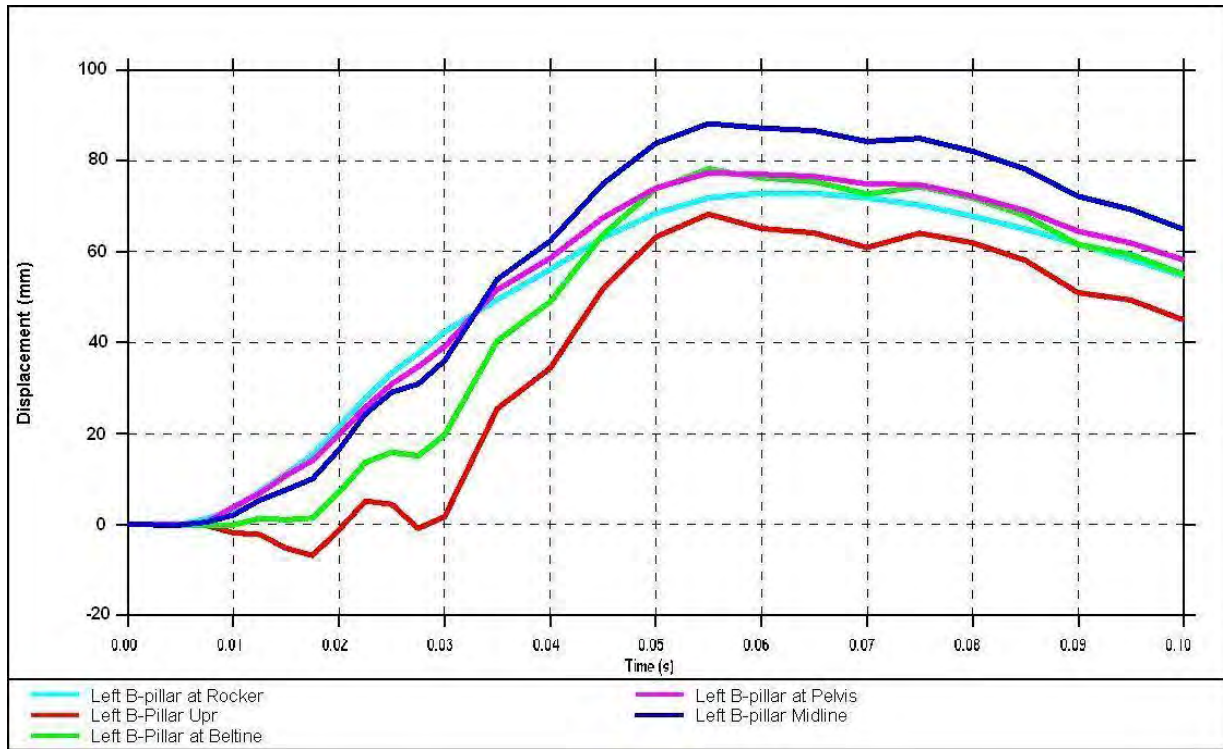

Figure 4.3.9.d: Relative intrusion displacements during 75°, side, pole impact (B-pillar) – 50th percentile male

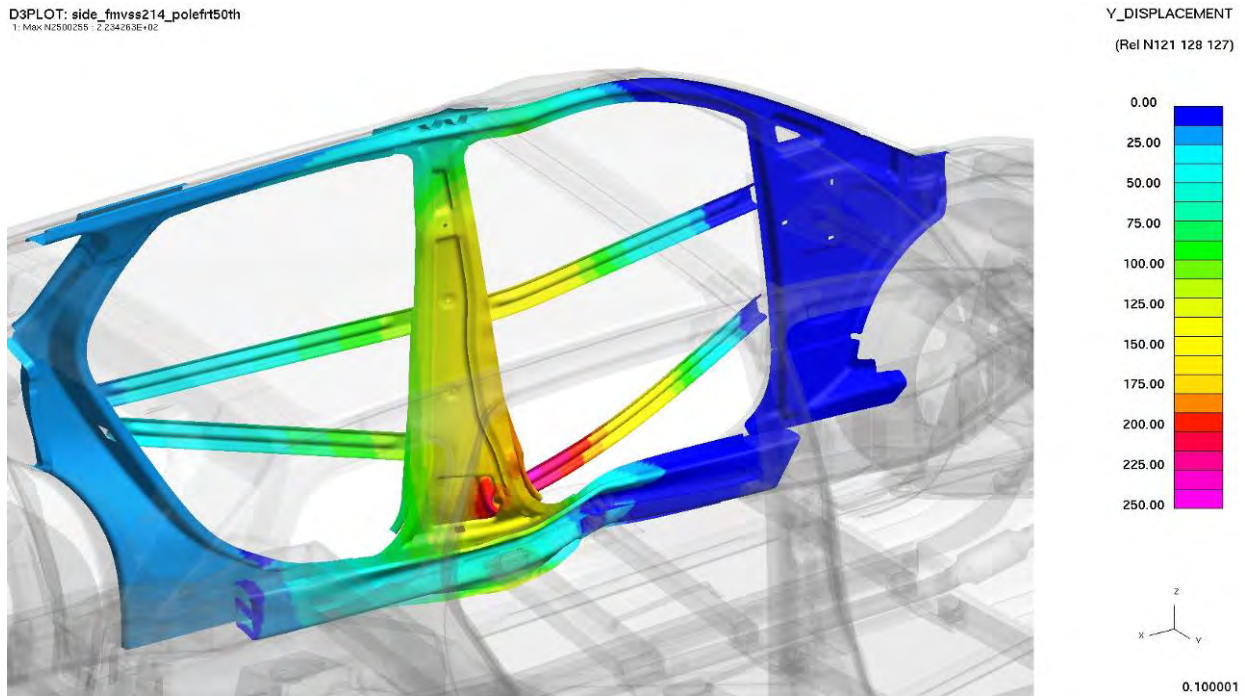

Figure 4.3.9.e: Intrusion levels after 75°, side, pole impact on struck side – 50th percentile male

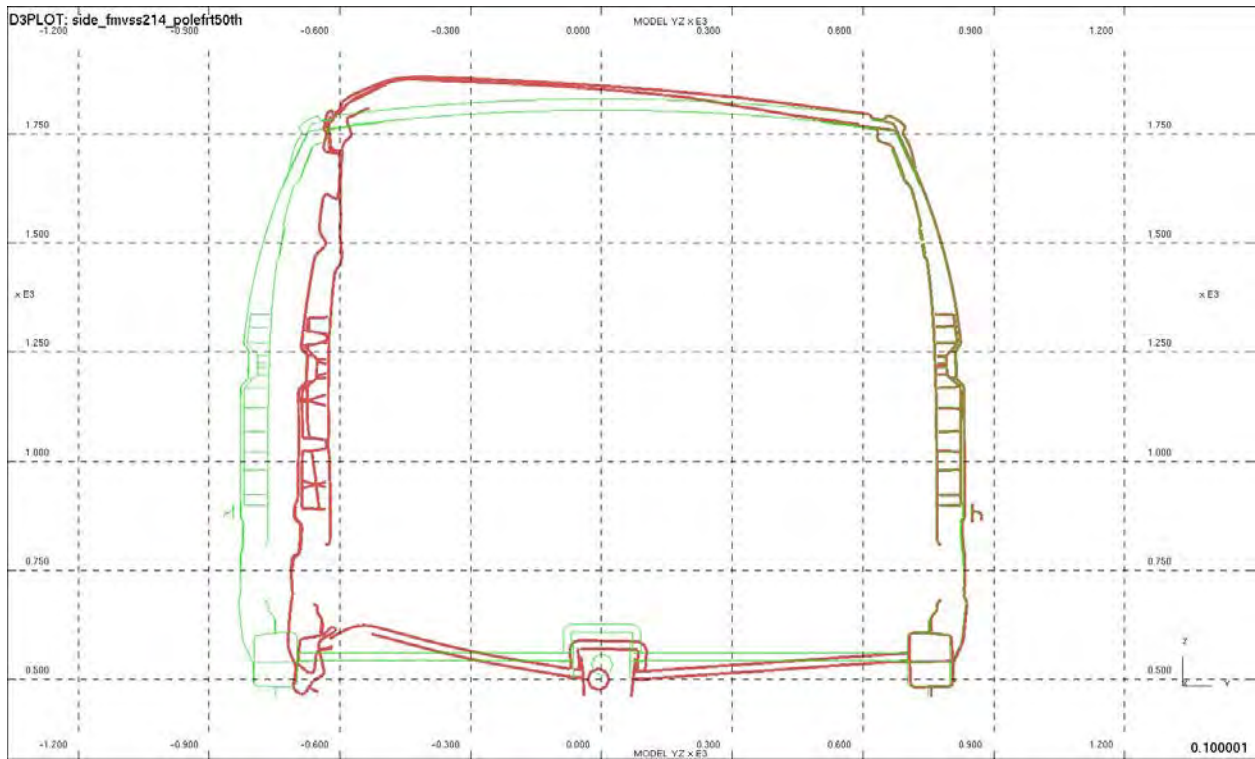

Figure 4.3.9.f: Section through B-pillar after 75°, side, pole impact, $x=2842 - 50^{th}$ percentile male

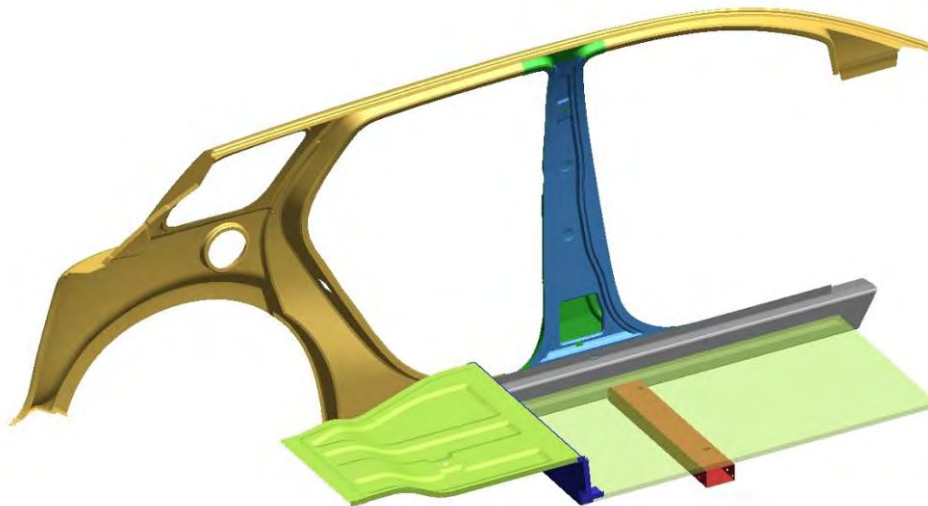

Figure 4.3.9.g: Main energy absorbing body structure for 75°, side, pole impact – 50th percentile male

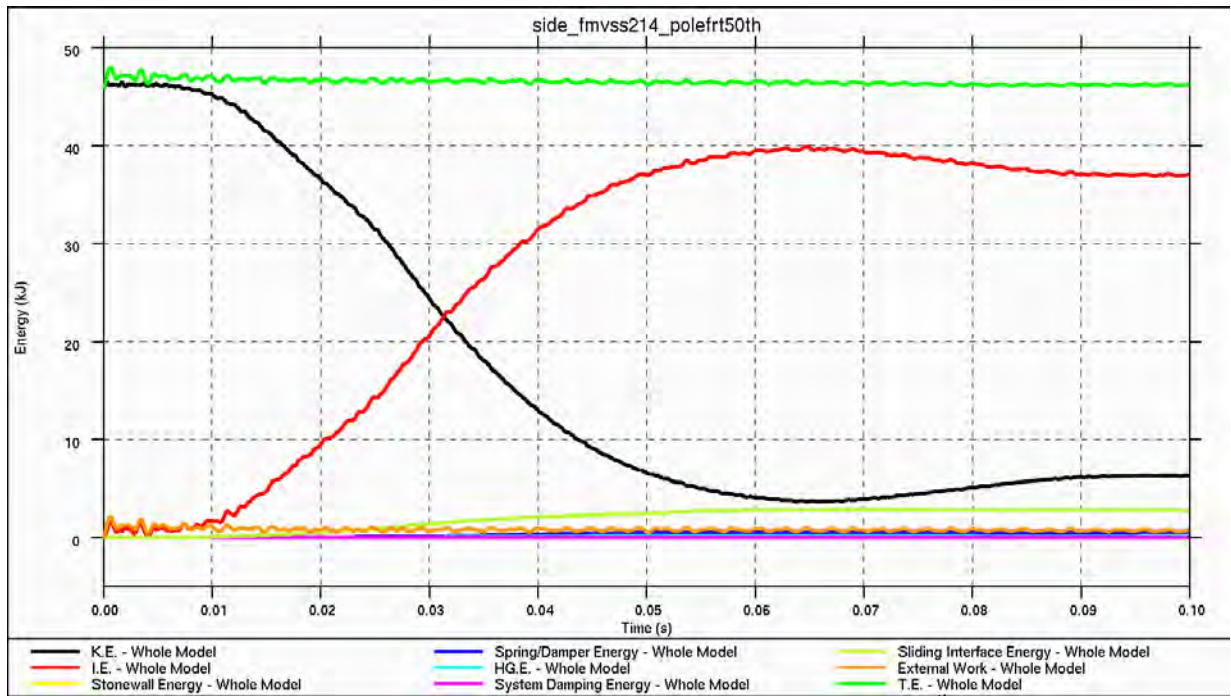

Figure 4.3.9.h: Energy balance for 75°, side, pole impact – 50th percentile male

This energy balance verified the analysis, showing no energy was created or destroyed during the simulation.

4.3.10. FMVSS 216: Roof Crush

The roof crush CAE analysis is shown below, where the platen is loaded to three times the curb weight of the vehicle and must not displace more than 127 mm and load a 95th percentile male's head to more than 222 N (50 lbs). This analysis shows that the Phase 2 HD BIW meets this standard as only 20 mm of displacement is predicted at three times the vehicle curb weight, which does not even touch the occupant's head.

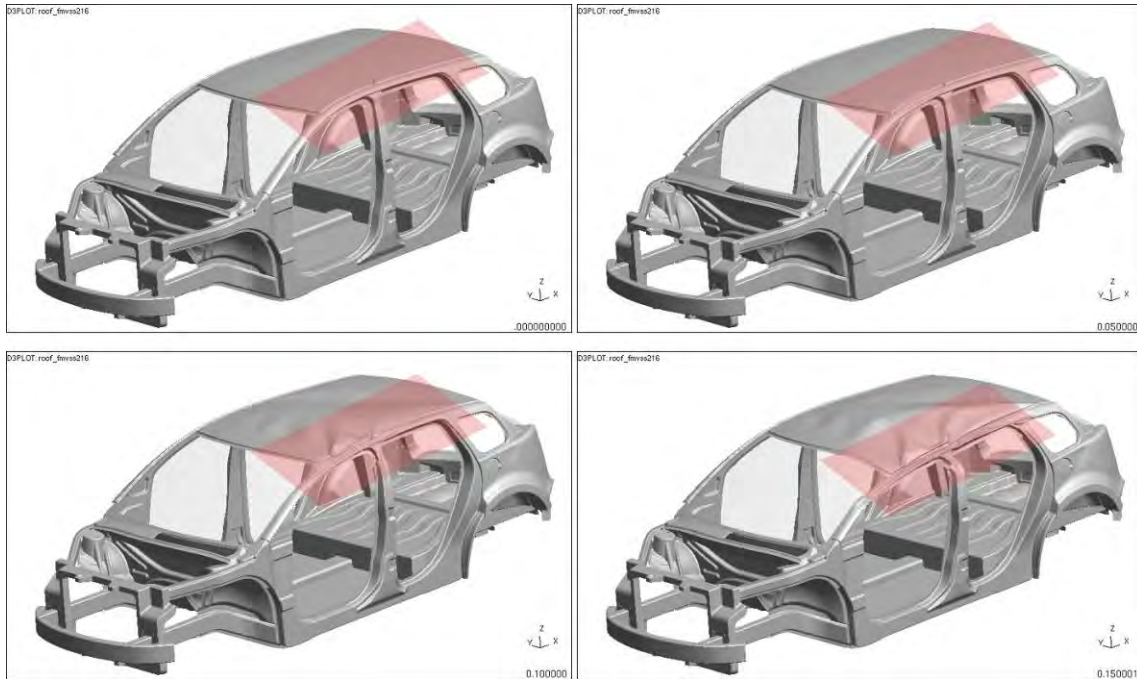

Figure 4.3.10.a: Deformation at 0/40/80/150 mm of roof crush platen displacement

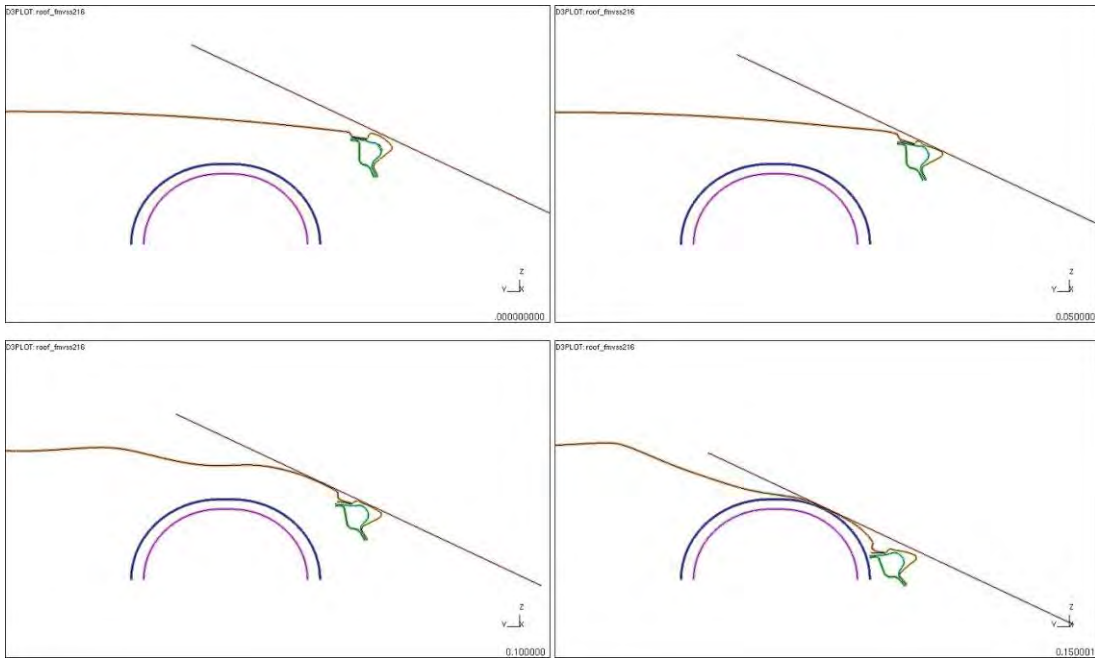

Figure 4.3.10.b: Deformation in relation to occupant head clearance zones (95th/99th) at 0/40/80/150 mm of roof crush platen displacement

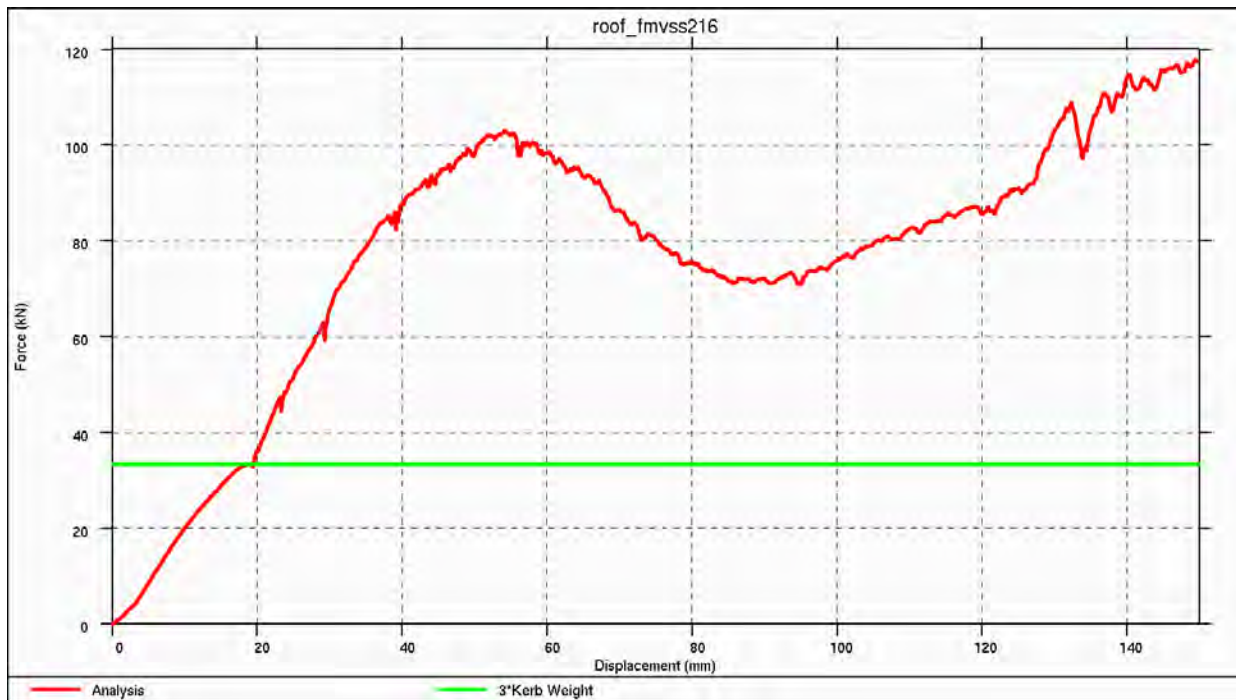

Figure 4.3.10.c: Roof displacement vs. applied force – 3 times curb weight

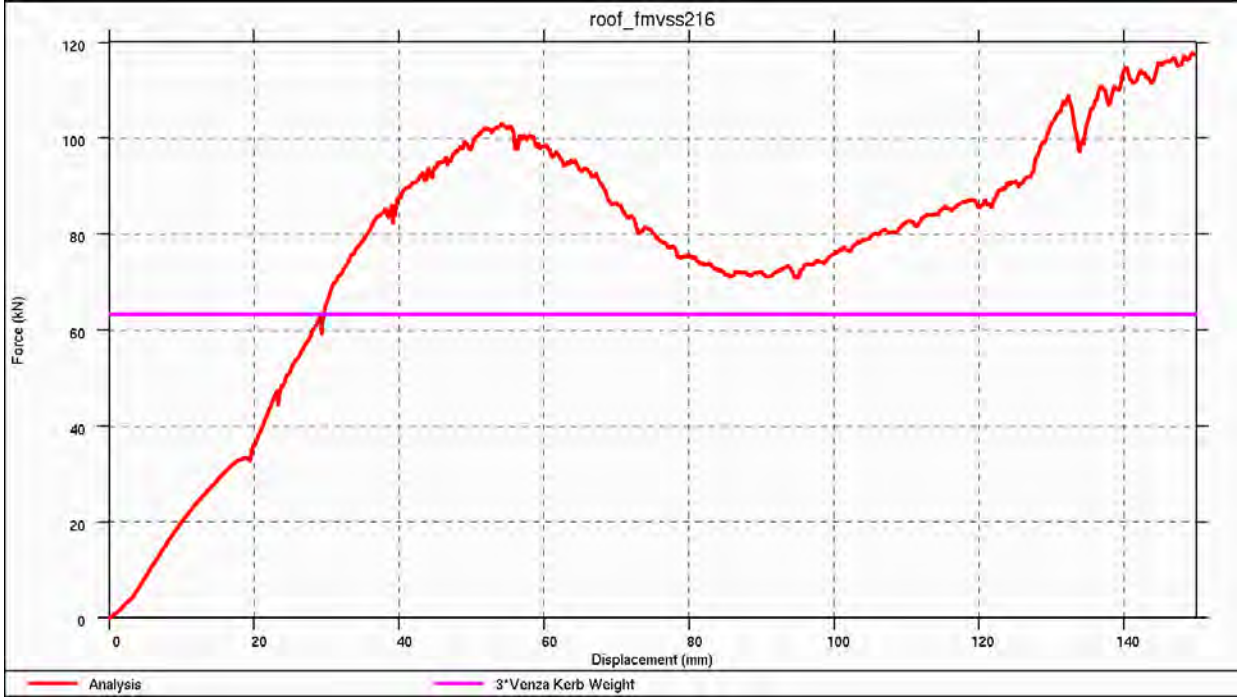

Figure 4.3.10.d: Roof displacement vs. applied force – 3 times Venza weight

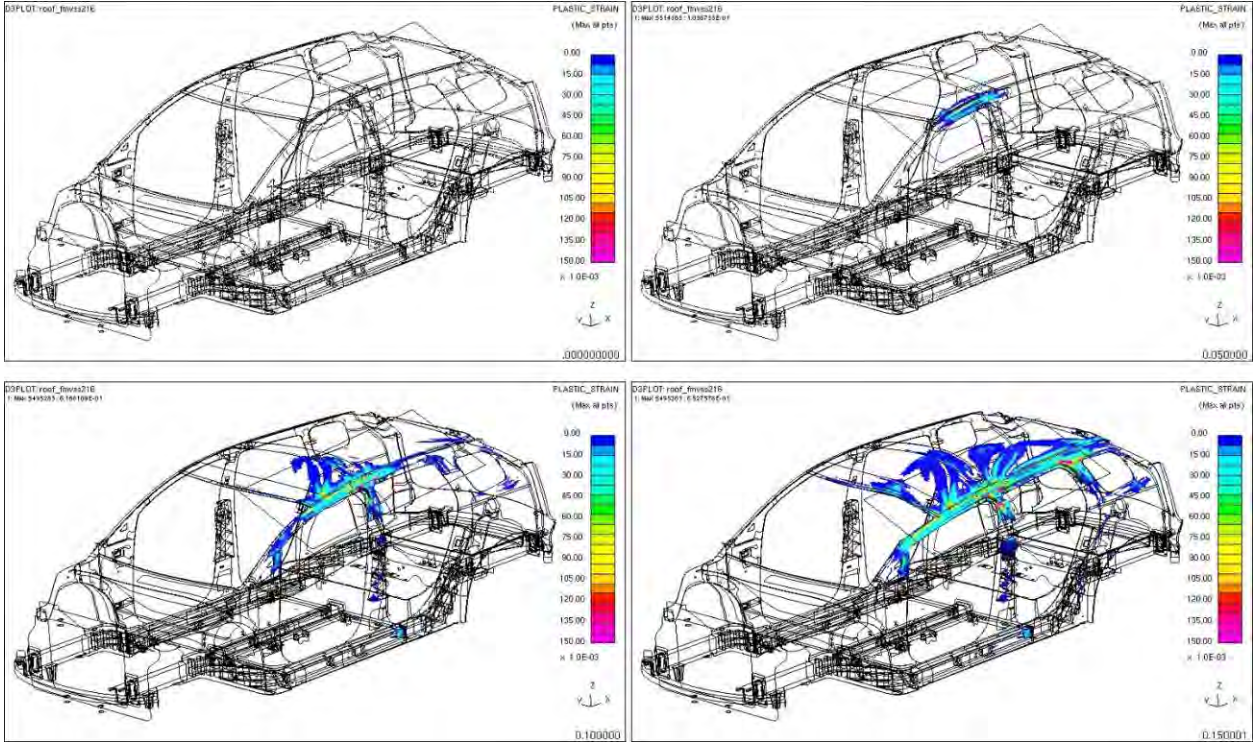

Figure 4.3.10.e: Roof plastic strains at 0/40/80/150 mm of roof crush platen displacement

4.3.11. FMVSS 301: Rear Impact (moving deformable barrier)

The rear impact test is designed to test fuel system integrity, allowing a maximum strain of ten percent. The CAE analysis below indicates a strain of less than 3.5 percent after the test, confirming fuel system integrity.

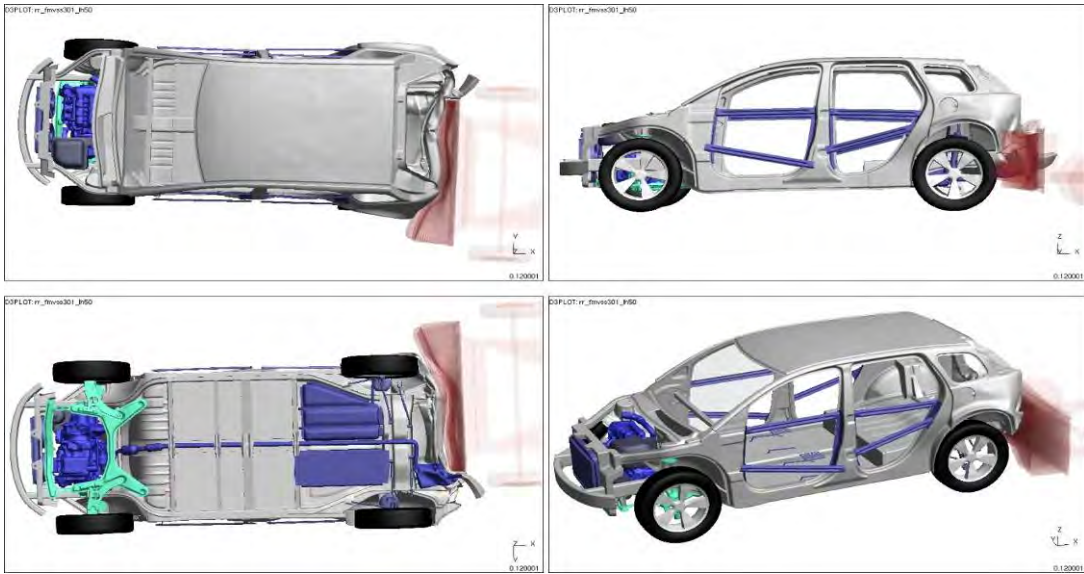

Figure 4.3.11.a: Vehicle deformation ($t=0.12$ s) after rear deformable barrier impact

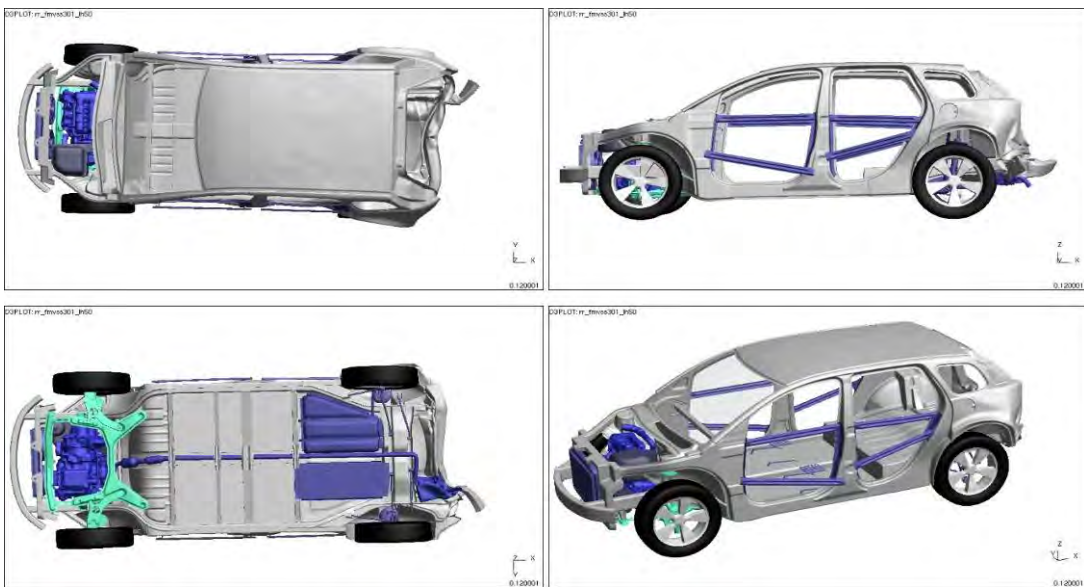

Figure 4.3.11.b: Vehicle deformation (barrier blanked) after rear deformable barrier impact

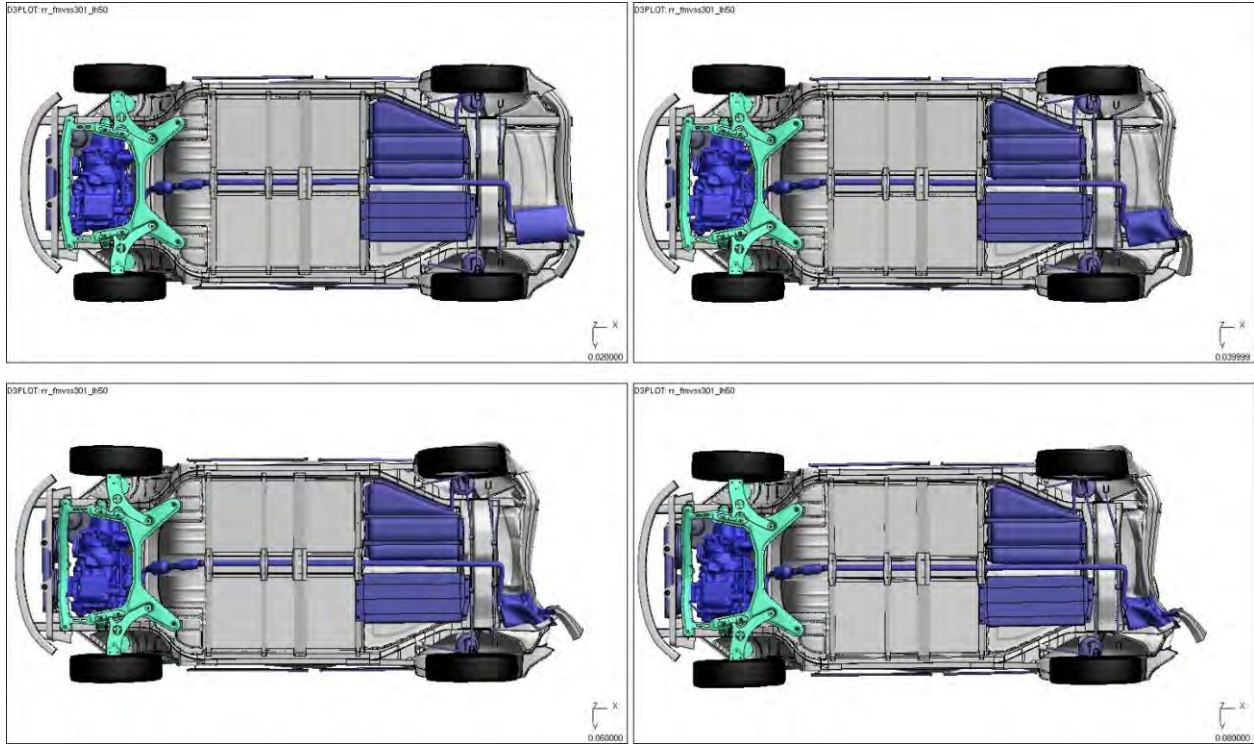

Figure 4.3.11.c: Vehicle deformation (at 0/40/80/120 ms) after rear deformable barrier impact

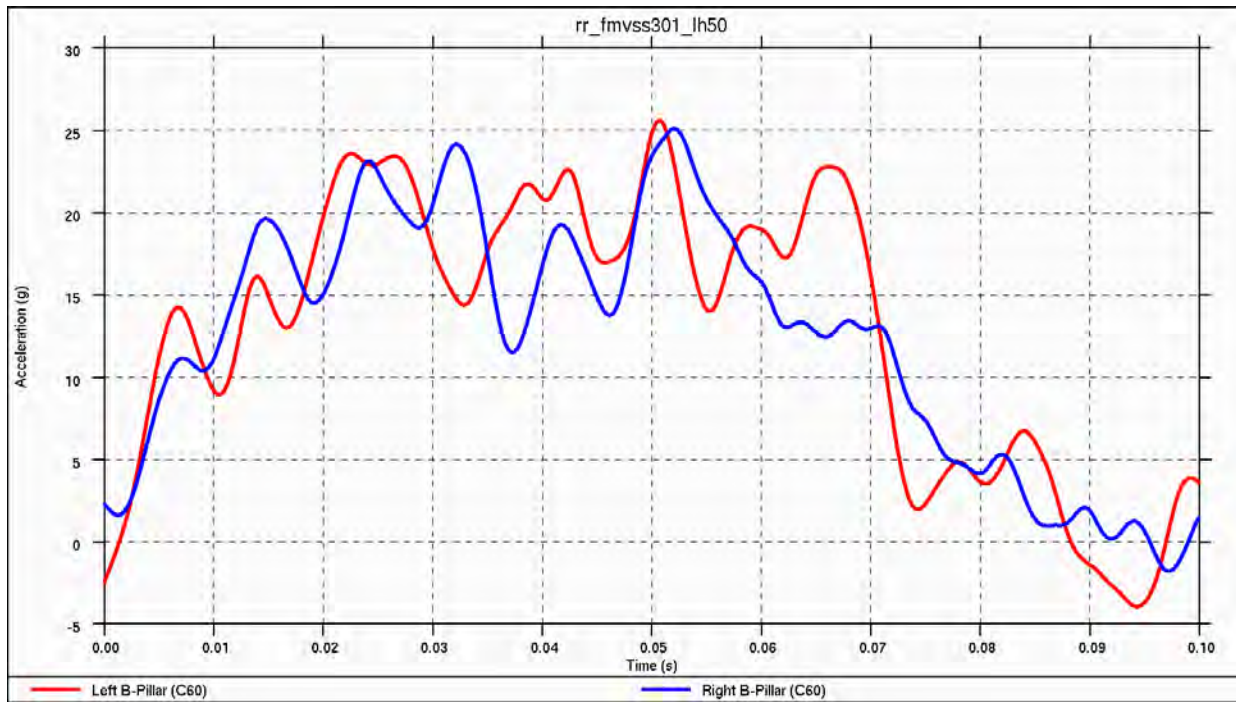

Figure 4.3.11.d: Vehicle acceleration pulse during rear deformable barrier impact

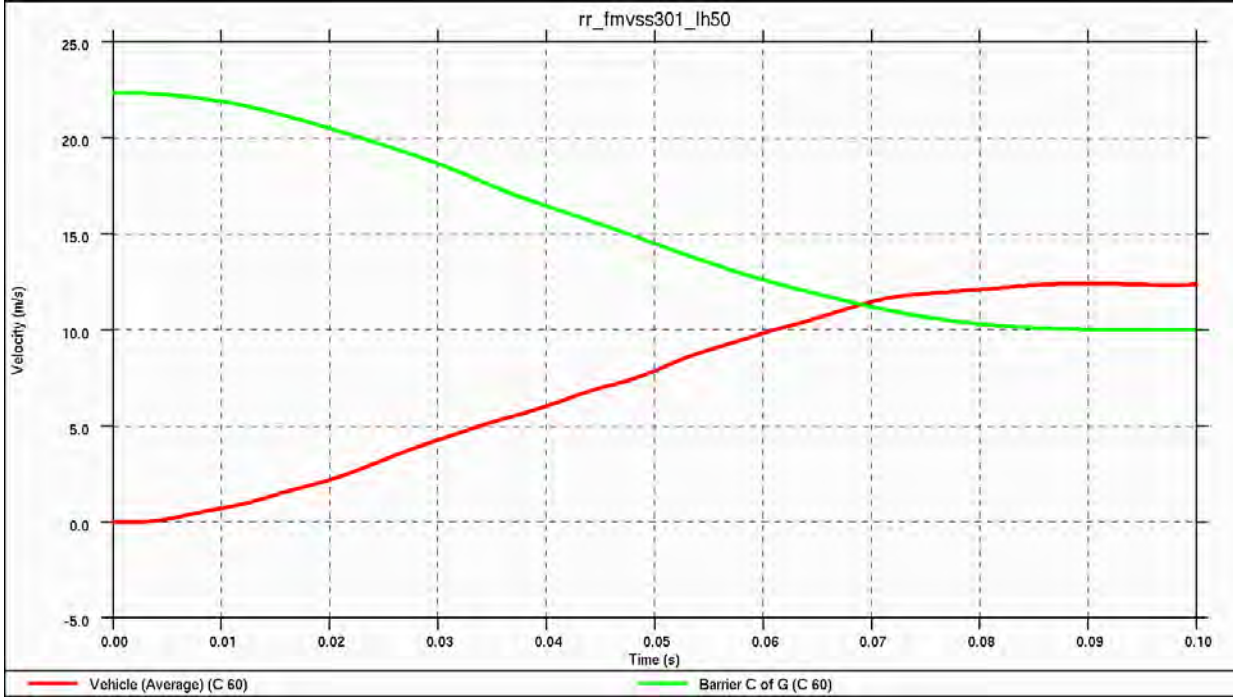

Figure 4.3.11.e: Vehicle and barrier velocities during rear deformable barrier impact

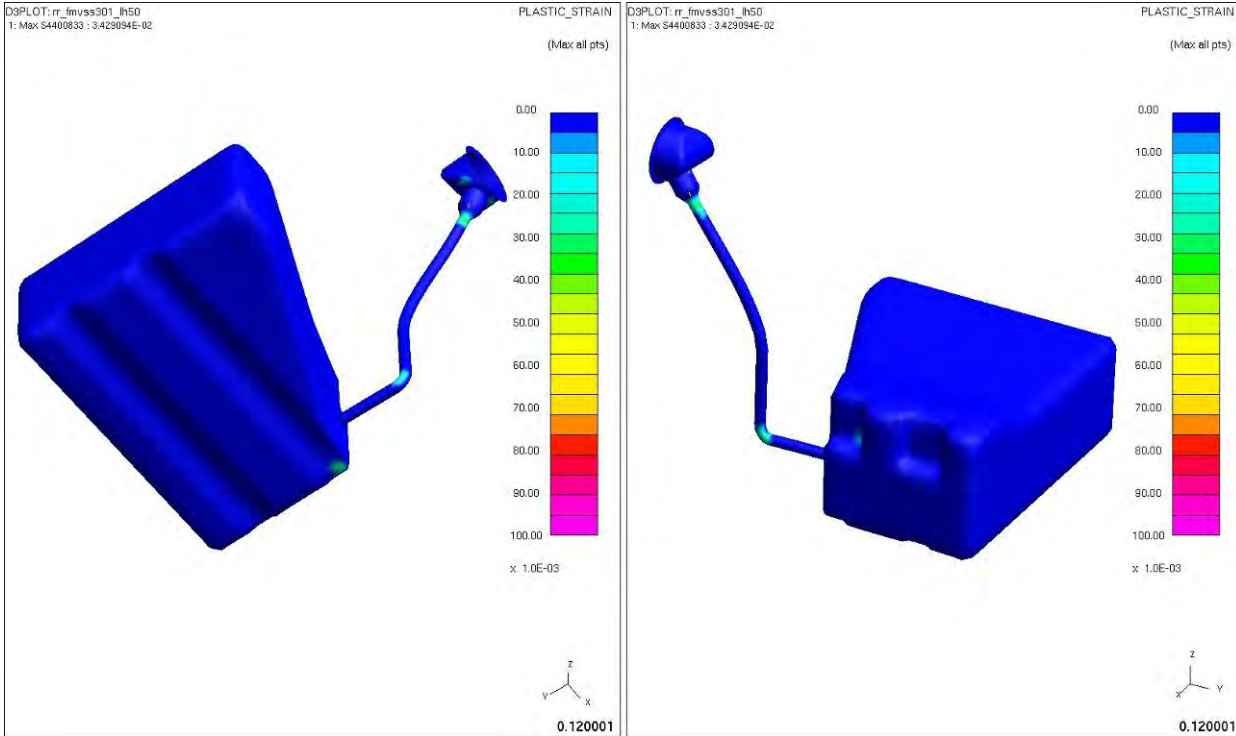

Figure 4.3.11.f: Fuel tank plastic strains after rear deformable barrier impact

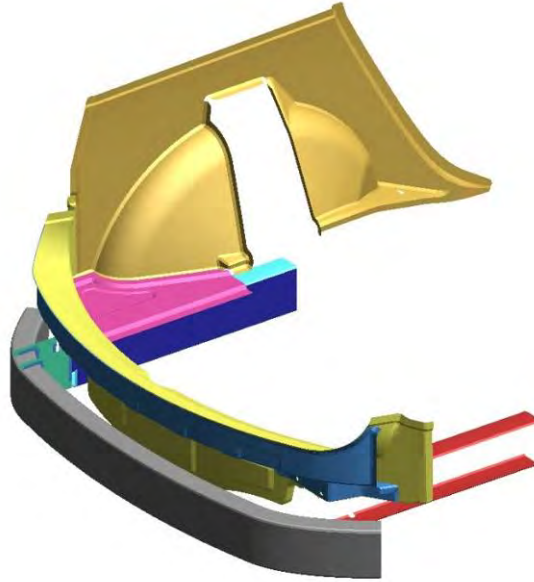

Figure 4.3.11.g: Main energy absorbing body structure for rear deformable barrier impact

The energy balance verified the model as the total energy was maintained.

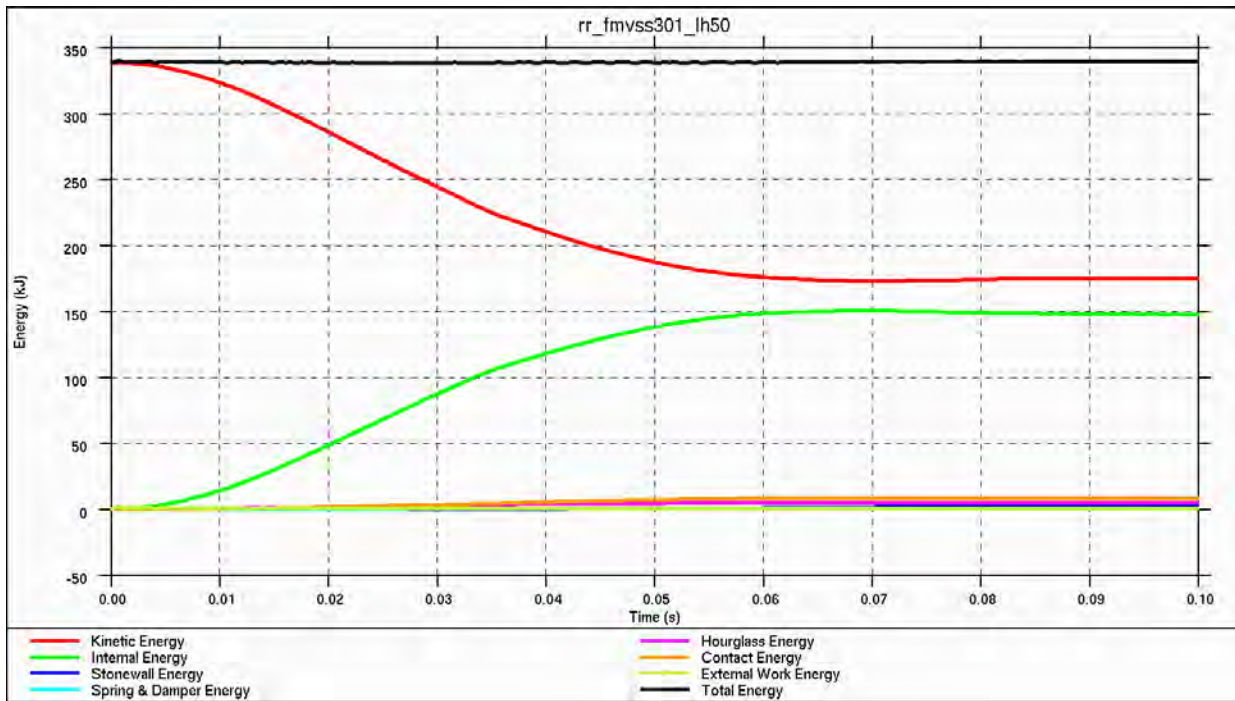

Figure 4.3.11.h: Energy balance for rear deformable barrier impact

4.3.12. IIHS Low Speed – Front

This test is designed to examine the damage and repair costs to the front bumper and fascia, which cannot be fully completed as it was beyond the scope of the project. Examining the plastic strain of the bumper beam shown in the CAE analysis below gives an indication of the potential damage.

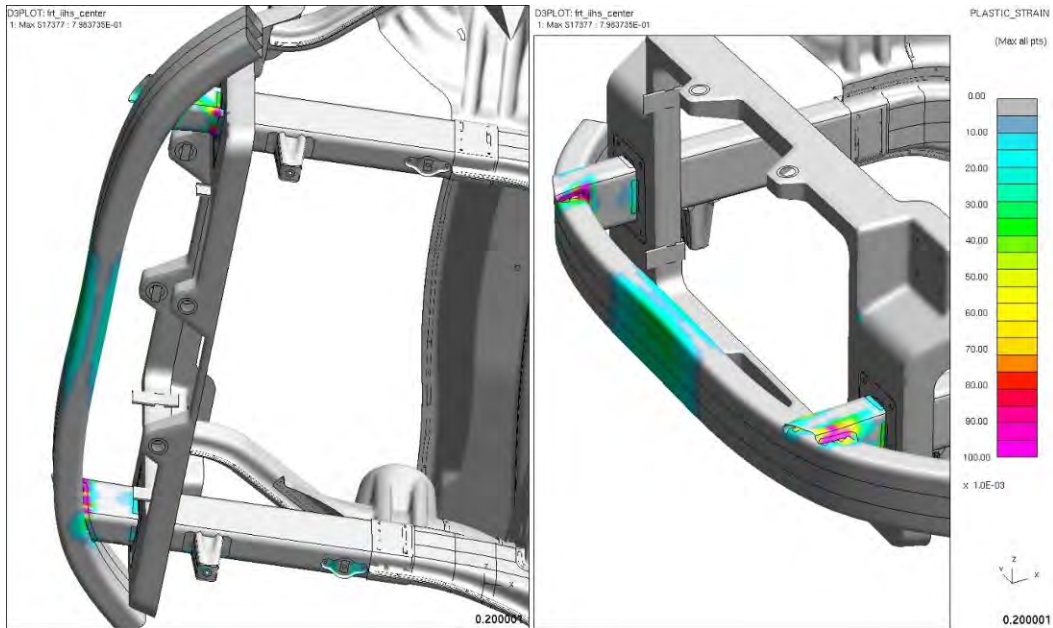

Figure 4.3.12.a: Front plastic strain after low-speed frontal impact ('full impact')

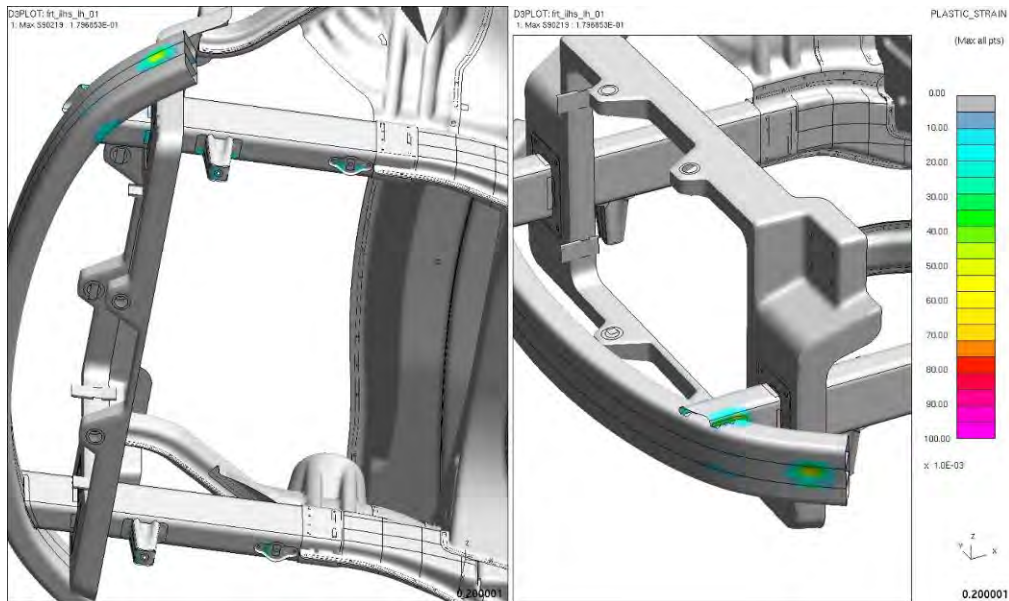

Figure 4.3.12.b: Front plastic strain after low-speed frontal impact ('offset impact')

4.3.13. IIHS Low Speed – Rear

The IIHS low speed rear impact test is designed to look at repair costs in the event of a rear-end collision. As with the frontal impact scenario, the repair costs cannot be estimated for the Phase 2 HD, but the damage can be estimated from the plastic strain in the bumper beam.

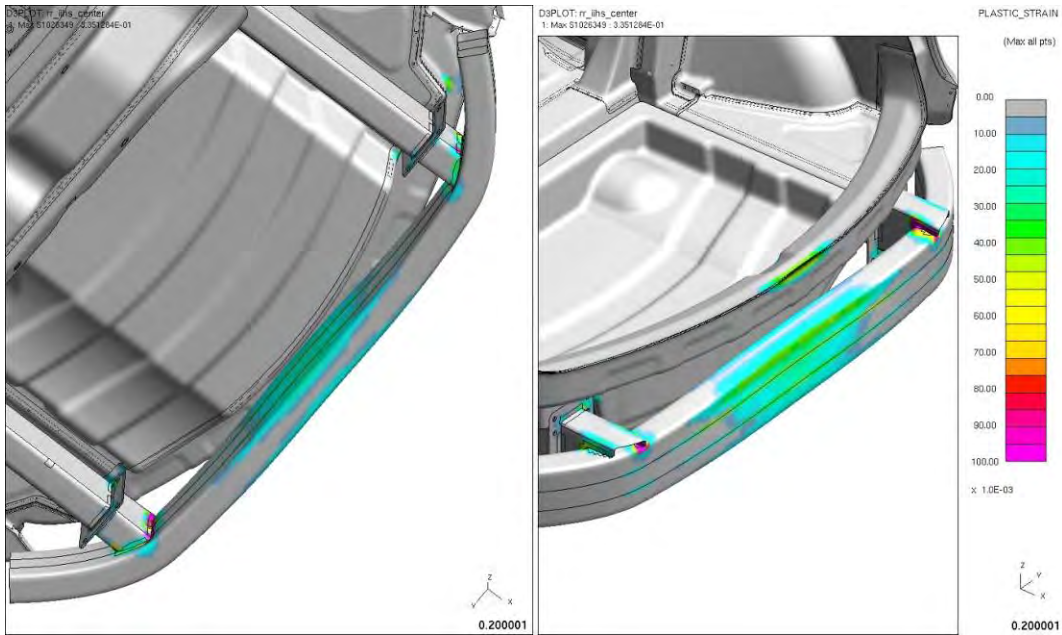

Figure 4.3.13.a: Rear plastic strains after low-speed rear impact ('full impact')

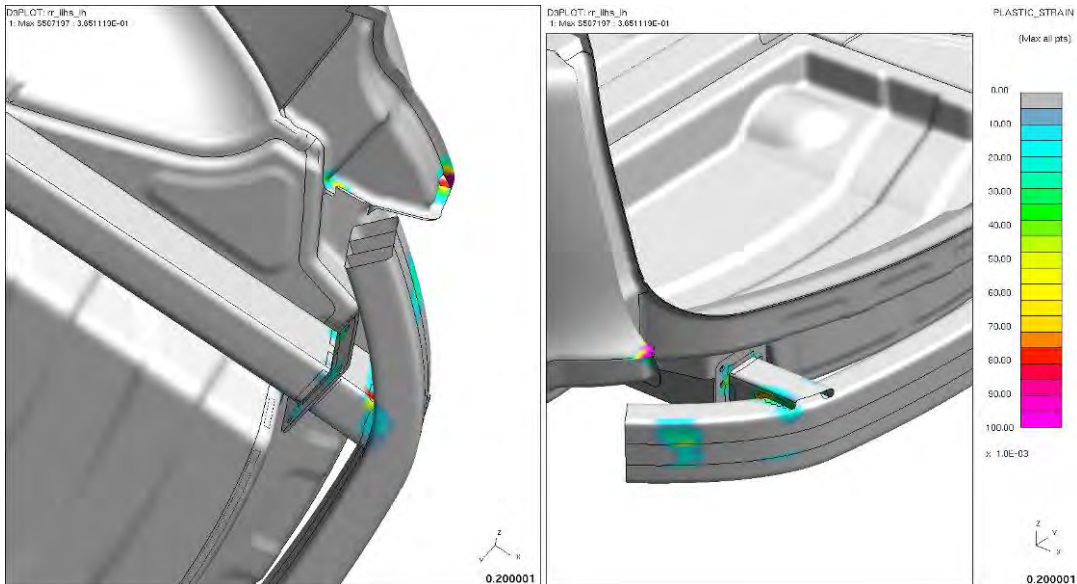

Figure 4.3.13.b: Rear plastic strains after low-speed rear impact ('offset impact')

4.3.14 Body Stiffness

The body stiffness was analyzed using MSC/Nastran[®] software to determine the torsional stiffness. The torsional stiffness is 32,900 Nm/degree for the low mass model. The BMW X5, a unibody SUV, was selected as the target vehicle as it is generally regarded as having ‘world class’ torsional stiffness. The published value for the X5 body structure is 27,000 Nm/degree³. The X5 body incorporates UHSS, aluminum and magnesium and is 15-percent stiffer than the previous version with virtually no weight penalty.

Creating a vehicle with a high torsional stiffness has a number of benefits to consumers as well as automakers. It allows for a better suspension design as the suspension doesn’t need to be tuned to compensate for large amounts of chassis flex; the vehicle will exhibit more predictable handling behavior because of these factors. **A higher torsional stiffness can also contribute to structural robustness. Depending on the design, a flexible chassis may accelerate cycling fatigue and possibly initiate cracking earlier than a stiffer chassis.**

Table 4.3.14.a: Torsional stiffness

| Torsional Stiffness | Torsional Stiffness |
|-------------------------|---------------------|
| | (kNm/deg) |
| Phase 2 HD 2011-01-06-2 | 32.9 |

Contour Plot
Displacement(Z)
Analysis system

1.584E+00
1.232E+00
8.803E-01
5.283E-01
1.763E-01
-1.758E-01
-5.278E-01
-8.799E-01
-1.232E+00
-1.584E+00

Max = 1.584E+00
Node 116114
Min = -1.584E+00
Node 109629

D:\arb\stiff\2011-01-06\biw_ver20_06_stiff_v01_04.op2
Result : D:\arb\stiff\2011-01-06\biw_ver20_06_stiff_v01_04.op2
SUBCASE 1 = TORSION : Simulation 1
Frame 4

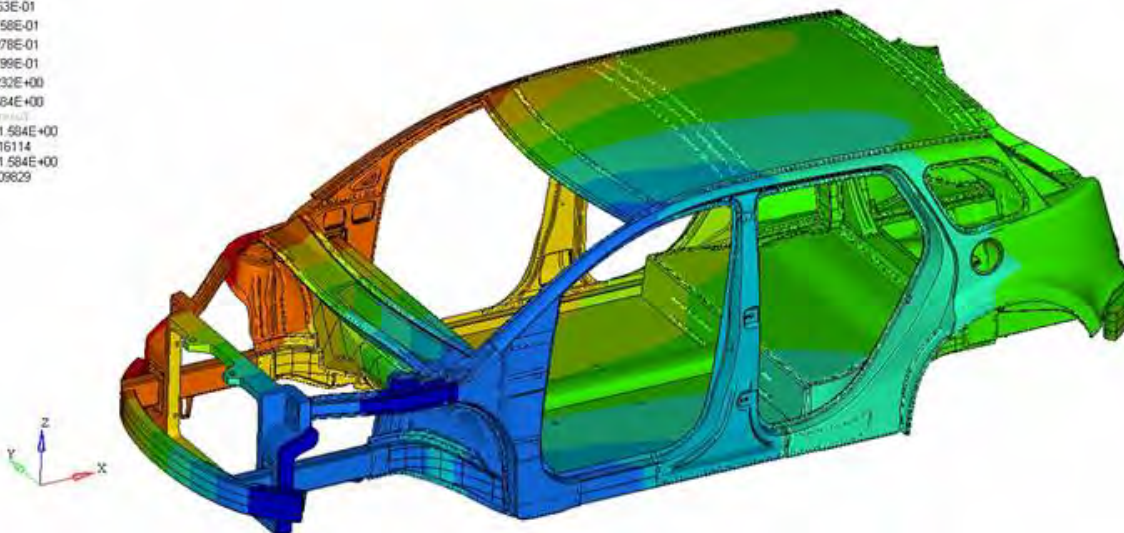

Figure 4.3.14.a: CAE body stiffness analysis

Table 4.3.14.b below gives a comparison of the Phase 2 HD torsional stiffness to other vehicles in a variety of classes. As can be seen in the table, a torsional stiffness of 32,900 Nm/degree is competitive even amongst sports cars, which have an average torsional stiffness of 25,427. It is also competitive with other SUVs, which have an average torsional stiffness of 26,350 Nm/degree.

Table 4.3.14.b: Torsional stiffness comparison

| Vehicle | Torsional Stiffness (Nm/degree) |
|------------------------|---------------------------------|
| Phase 2 HD | 32,900 |
| Sports cars | |
| Aston Martin DB9 Coupe | 27,000 |
| Audi TT Coupe | 19,000 |
| BMW M Coupe | 32,000 |
| Ford GT | 27,100 |
| Königsegg CCX | 28,100 |
| Lamborghini Gallardo | 23,000 |
| Lamborghini Murciélago | 20,000 |
| Mazda RX-8 | 30,000 |
| McLaren F1 | 13,500 |
| Pagani Zonda F | 27,000 |
| Porsche 911 Carrera | 33,000 |
| Average | 25,427 |
| SUVs | |
| BMW X5 | 27,000 |
| BMW X6 | 29,000 |
| Land Rover LR2 | 28,000 |
| Volvo XC90 | 21,400 |
| Average | 26,350 |
| Luxury cars | |
| Aston Martin Rapide | 28,390 |
| Audi A8 | 25,000 |
| BMW 7 Series | 28,505 |
| Jaguar XJ | 20,540 |
| Lexus RX | 18,280 |
| Maserati Quattroporte | 18,000 |
| Mercedes-Benz S-Class | 25,400 |
| Volvo S80 | 18,600 |
| Average | 22,839 |
| Standard cars | |
| Audi A2 | 11,900 |
| BMW 3 Series | 22,500 |

| | |
|----------------|--------|
| Jaguar X-Type | 22,000 |
| Mini Cooper | 24,500 |
| Volkswagen Fox | 17,941 |
| Volkswagen GTI | 25,000 |
| Volvo S60 | 20,000 |
| Average | 20,549 |

4.4. Discussion

This section discusses the results obtained during the CAE analyses and how the FEA model results indicate that there is potential for this design to meet FMVSS regulations and IIHS requirements. No direct comparison with the Venza can be made as the public domain impact results are for an actual production vehicle.

An industry accepted standard for the software fidelity used for modeling is in the 5% to 10% range. The maximum allowable peak acceleration target for front impact modeling was 90% of the Venza peak acceleration as measured and reported by NHTSA.

Lotus utilized the same analysis techniques used to make production vehicles in order to give the best possible results. The results are, however, based on engineering software analyses rather than physical results. Overall, the Phase 2 HD acceleration levels are comparable to production vehicles and, based on the CAE data, shows a properly engineered, light weight vehicle has the potential to meet US federal crash requirements.

NHTSA provided energy balance input for the simulations and these are included with the Lotus analyses. The objective was to verify that there was no loss or gain of energy during the impact; such an event would indicate a modeling error. A zero net energy balance does not confirm the model accuracy.

Durability analysis was beyond the scope of this study. However, the design utilized Lotus fatigue and corrosion experience with aluminum riv-bonded structures, as well as that of the participating material suppliers, including Alcoa, Meridian and Henkel. This resulted in potentially increased mass in some areas, e.g., the “B” pillars, where the structure was stiffer than required to meet the test requirements but was retained based on previous cycling fatigue experience.

4.4.1. Observations - FMVSS 208 Front Impact

FMVSS 208 deals with occupant protection, specifying maximum forces, accelerations, and Head Injury Criteria (HIC) levels. Developing a full vehicle with tuned occupant restraint systems, seats, and full interior was beyond the scope of this contract and as such, Lotus based its CAE crash test analyses on vehicle crash acceleration data rather than occupant criteria. The data shows the model has the potential to have performance comparable to existing production vehicles with all accelerations at acceptable levels. Furthermore, the occupant restraint system (the full Venza airbag system is included in the vehicle mass) would be tuned specifically to handle the specific acceleration pulses of the Phase 2 HD vehicle.

A material thickness sensitivity study was also conducted and found that acceleration levels could be reduced by over 30 percent by reducing wall thickness 10 percent in key

areas, giving substantial opportunity to refine local acceleration pulses. Based on Lotus' experience, material thicknesses were not reduced due to potential durability concerns.

The front structure is primarily aluminum and the use of magnesium was kept to areas outside of primary load paths due to the brittle nature of magnesium compared to steel and aluminum. The high loads experienced during a crash mean that magnesium is more likely to crack rather than crumple and absorb energy.

4.4.1.1 FMVSS 208: 35 mph Front Impact (0°/30° rigid wall, offset deformable barrier)

Maximum dash intrusion of less than 20 mm -- and less than 15mm in most areas -- when subjected to the FMVSS 208 35 mph frontal impact indicates acceptable structural performance in this area. Analyses revealed this is primarily due to minimal intrusion of the engine bay components into the dash panels.

Some of the crash energy is absorbed by the magnesium dash panel, which is why there is some intrusion into the passenger compartment, but the majority of the crash energy is absorbed in the front bumper, bumper brackets, and the right and left main rails. A secondary load path to the structure is created by the engine and sub-frame, meaning the sill and body structure have less energy to absorb. The tires don't contact the sill and the A-pillar lower remained intact, indicating that most of the impact energy was absorbed by the front structure.

4.4.1.2 FMVSS 208: 25 mph Offset Deformable Barrier

This is a generally less severe test case than the 35 mph rigid barrier as the barrier can absorb up to 50 percent of the total impact energy. The test results reflect this as the maximum dash intrusion is < 6 mm, indicating acceptable performance in this test.

The majority of the crash energy is absorbed in the front bumper, front end module, left bumper bracket, and left main rail due to the barrier overlap location. The engine and sub-frame once again create a secondary load path, reducing the energy the sill and body structure have to absorb.

4.4.1.3 FMVSS 208: 25 mph 30° Flat Barrier – Left Side

Dash intrusion for this load case was < 15 mm, showing acceptable crash performance. This load case is a mix of the flat rigid wall and offset deformable barrier test as the vehicle impacts a flat, rigid wall at a 30° offset, with the left side contacting the wall first. The acceleration pulses are therefore asymmetrical again with the left side absorbing more crash energy.

The crash energy is once again mostly absorbed in the front bumper, front end module, left bumper bracket, and left main rail. The left shotgun inner and left front shock tower also absorb some of the crash energy as well as the engine and sub-frame. More of the energy is transmitted and absorbed by the magnesium dash panel in this test case as well, as indicated by the higher intrusion level.

4.4.1.4 FMVSS 208: 25 mph 30° Flat Barrier – Right Side

As with the left-side barrier impact, dash intrusion levels for the right-side barrier test case were < 15 mm indicating acceptable structural performance. The right side of the vehicle contacted the wall first, causing the right side of the front end structure to do more work than the left with a few minor differences.

The front bumper, right bumper bracket, right main rail, front end module, and dash reinforcement absorb most of the crash energy. The shotgun inner and shock tower don't absorb any of the crash energy in this impact case due to the new load path through the engine and its ancillary mounting locations. These mounting locations, and therefore load path, are not present on the left side. As a result of the direct loading through the engine, it contacts the dash crossmember sooner, transmitting more load.

4.4.2. Observations – FMVSS 210 Seatbelt Anchorages

FMVSS 210 is concerned with seatbelt retention and also specifies certain dimensional constraints for the relationship between the seatbelts and seats. Designing a full interior with seats was beyond the scope of this project. The loads were tested on the body structure anchorages which would be used to attach the rear portion of the seat.

Overall, both the front and rear seatbelt anchorages performed as expected, meeting the specified requirements. Strains for both systems were elevated due to the lack of modeled seats, but did not cause the Phase 2 HD BIW to fail. The front and rear anchorages are broken out below.

4.4.2.1. Front Anchorages

Although the strain in the lower anchorage points (rear, front-seat mounts) is elevated, the simulation shows acceptable structure for seatbelt retention. The elevated strain in the lower anchorage points is due to a lack of modeled seats, which were beyond the project scope, and thus transferred load through only two points instead of four as the front seat mounts were not defined. This is a worst case analysis as the majority of the load is supported by a combination of the composite sandwich floor and the aluminum structure. The seat will be mounted to a more structural aluminum cross-member under the floor.

This strain around the belt attachment location is artificially high due to the method used to attach the belts to the structure. Typically in CAE analysis there is higher stress at the

point of load application than would be seen in reality as the clamping effects of fasteners between the parts are not modeled.

The upper anchorage location shows there will be localized deformation, but no detachment of the anchorage. It should be noted that the D-ring attachment on the B-pillar typically allows for height adjustment and would therefore have a larger reinforcement than included on the Phase 2 HD body structure. This larger reinforcement would help spread the load and reduce the deformation and strain seen in this area. The existing structure is adequate for this purpose.

4.4.2.2. Rear Anchorages

Simulation results show the model has acceptable structure for seatbelt retention and the analysis predicts the highest strain areas are at the outboard lower-belt attachment locations. The plastic strain around the D-ring attachment is less than the strain shown in the front seatbelt pull analysis results. This is partly attributed to the narrower section which makes it stiffer than the same belt mounting location on the B-pillar.

Approximately 100 mm of rear-seat pan deformation between the two center belt mounting locations is predicted under this load case. The strain in this area is relatively low (<6 percent), indicating that the mounting plates would not pull through the seat pan when tested in this configuration. An additional fore/aft reinforcement could be mounted under the seat pan to reduce the total deformation at the center belt mounting locations.

4.4.3. Observations – FMVSS 213 Child Restraint Anchorage

This test is less severe (in terms of applied load) on the body structure than the seatbelt anchorage load case of FMVSS 210. The primary concern of this test is to ensure the child restraints will restrain a child under crash conditions, meaning the anchorages should not pull out of the vehicle. While less severe than the load case of FMVSS210, the load is still higher than required by FMVSS 213 as a 30-kg mass was used instead of the required 21-kg mass. The model shows acceptable structure for child restraint anchorage with the added load.

The mounting locations for the child restraints were the same as for the seatbelt pull and the results indicate there should be no fracture or tearing of these mounting locations under this load case. This indicates the anchorage could be designed to hold once full seating and a full vehicle are developed as well.

4.4.4. Observation – FMVSS 214 Side Impact

The CAE analysis results of the FMVSS 214 side impact test show the Phase 2 HD BIW sill, B-pillar, and side door beam sub-systems effectively manage the side impact crash

energy. The three FMVSS 214 side impact test results are broken down below. These tests deal with occupant injury, which is beyond the scope of this project, so a maximum allowable intrusion level of 300 mm was instituted. This is defined as the typical distance between the door panel and most outboard seat surface.

4.4.4.1 FMVSS 214: 33.5 mph Crabbed Barrier

CAE analysis showed the body structure has acceptable performance when subjected to the FMVSS 214 crabbed barrier side impact test.

The Phase 2 HD BIW intrusion level was measured at 115 mm, meaning the door panel would not come into contact with the passenger. This likely prevents any possible injury caused by contacting the hard surface of the inner door panel as is the primary concern of the FMVSS 214 tests.

4.4.4.2 FMVSS 214: 20 mph 75° Side Pole Impact

This test is carried out using two different size dummies – 5th percentile female and 50th percentile male – and thus seating positions which moves the primary impact location due to the fact that the pole is lined up with the frontal occupant's CG.

CAE analysis for the 5th percentile female revealed the pole struck nearly in the middle of the A- and B-pillars with an intrusion level of 120 mm. This greatly surpasses the Lotus-defined test requirements with a maximum allowable intrusion of 300mm.

A similar analysis was conducted for the 50th-percentile male with the seat and impact location moved accordingly. Intrusion for this test was measured at 190 mm, far below the 300 mm allowed indicating acceptable structural performance.

Analyses showed the body structure has acceptable structural performance when subjected to the load cases of FMVSS 214. The intrusion was measured at 115 mm for the 33.5 MPH crabbed barrier. The intrusion for the 20 mph 75 degree pole test for a 5th percentile female was 120 mm. The intrusion for the 20 mph 75 degree pole test for a 50th percentile male was 190 mm. This indicates that the sill, B pillar and side door beam sub-systems are managing the energy in an effective manner.

4.4.5. Observation – FMVSS 216 Roof Crush

Simulations predict the Phase 2 HD vehicle will meet roof crush performance requirements under the specified load case. Only 20 mm of platen displacement was predicted to meet the 3*vehicle weight requirement. The simulation suggests that the requirement would be met even if the baseline Toyota Venza curb weight was used (e.g. a 45-percent increase).

The significant difference between the Phase 2 HD structure and that of a similar segment vehicle is due to the significant reduction in the curb weight (from 1700 kg to 1173 kg for the Phase 2 HD model). The body incorporates the structure of a larger segment vehicle even though the 3 time curb weight is similar to that of a small/medium passenger car.

Based on these results there could be some optimization of both the panel gauges and the A-pillar section for weight if all other structural requirements are met. Other load cases and manufacturing requirements would need to be evaluated in parallel to ensure all criteria would be met.

4.4.6. Observations – FMVSS 301 Rear Impact

FMVSS 301 deals with the integrity of the fuel system after a rear crash, aiming to prevent any fuel spillage. The test allows a maximum plastic strain of ten percent in the fuel tank and system after the crash event.

The maximum plastic strain in the fuel tank/system components is predicted to be less than 3.5 percent, validating that the fuel system meets FMVSS 301 which allows no more than 10-percent strain. There was no contact with the body structure or vehicle components.

The pressure change in the fuel tank is less than 2 percent so the risk of the tank splitting due to an increase in internal pressure (caused by compressing the outside of the tank) is predicted to be minimal.

Barrier to vehicle crossover velocity is predicted to occur at 69 ms from the initial contact.

Due to the offset bumper beam, dynamics of the rear impact are not ideal. The ideal failure mode is an axial crush under load (i.e. pure compression mode), but the offset bumper beam means the rear bumper armature rotates. This creates a torque which results in a bending moment into the rear rail, causing it to fail. The rear bumper, left bumper bracket, left rail, rear end lower panels, and horizontal surfaces of the right rail absorb most of the energy.

4.4.7. Observations - IIHS Low Speed – Front

The analyses of these two front impact load cases predict that only the bumper system components would yield.

The higher levels of plastic strain are predicted to be in the heat affected zones at the welded joint between the bumper armature and the bumper brackets. In these areas the material yield strength was reduced by 60 percent (from the un-welded material properties) to compensate for the annealing that occurs due to welding.

In the 'full' impact case there is deformation of the bumper armature as this flattens under loading, resulting in lateral loading at the bumper brackets.

Analysis of the offset impacts predicts there will be minimal damage to the bumper system because there is less than 75 mm of overlap between bumper armature and the end of the barrier. This results in a 'glancing' impact, where the vehicle is pushed sideways as it travels forwards due to the curvature of the outer end of the armature.

The styling may be required to change in this area to allow the bumper beam to be moved outboard and forward in the side contact area to reduce any potential damage. The Phase 1 front end styling moved the front lamps moved inboard and rearward of this contact area to minimize any possible damage to the lighting system. Developing the full front end styling, bumper system, lamps and sheet metal was beyond the scope of this project.

4.4.8. Observations - IHS Low Speed – Rear

The analyses of these two rear impact load cases predict there will be plastic strain in components other than the bumper system.

For the 'full' load cases there is some body deformation. Modifying the exterior styling to allow the addition of bumper foam would move the barrier contact point further away from the body panels, improving performance. Additionally, the barrier displacement could be reduced by tuning the foam density and thickness.

The 'offset' impact analysis indicates a result similar to that predicted for the front 'offset' load case. This is due to minimal engagement of the barrier and the curvature of the armature which is more aggressive than the front. The vehicle 'slides' inboard off the barrier rather than staying perpendicular to the line of travel. The analysis predicts that the vehicle will move ~50 mm inboard.

This analysis also indicated that the lower rear corner of the body could be damaged by the upper portion of the barrier. This concern would be addressed by incorporating local styling changes to the bumper system including reducing the plan view curvature, moving the bumper armature ends rearward at the outboard ends and increasing the distance between the bumper and the body panels. This can be done by moving the body panels forward and inboard relative to the existing bumper or adjusting the bumper relative to the existing sheet metal. These revisions would create additional clearance to the barrier and also allow energy absorbing material to be added to the bumper beam.

The rear bumper system is an example of the tradeoffs made between vehicle appearance and function. Preliminary styling concepts, such as the Phase 1 vehicle, do not necessarily comprehend all functional requirements even though they are based on 'best practices'. Engineering analysis is used to verify the feasibility of the styling relative to functional requirements. This analysis indicated that a styling adjustment should be made to improve the rear bumper low speed performance. This is a typical example of using analytical tools to verify functional performance very early in the styling process. There are no body structural issues.

4.4.9. Vehicle-to-Vehicle Crash Results

This section shows results of a simulated impact between the Phase 2 HD vehicle and a Ford Taurus. This information was requested by the NHTSA to compare the performance to their metrics. The crash simulation was run so that both vehicles had the same kinetic energy. The Phase 2 vehicle was run at 40 mph while the Taurus was run at 27 mph; this speed difference was required because of the much lighter Phase 2 model. These analyses however, were run by Lotus and may be setup differently than the NHTSA analyses so no specific comments can be made. NHTSA published their test results separately on August 30, 2012 (link provided previously).

No crash acceleration or intrusion levels were objectively measured because of the possible differences in setup between NHTSA and Lotus. What can be observed is that there is no intrusion into the Lotus model passenger cell. The single vehicle FMVSS test resulted in a maximum passenger cell intrusion of <22 mm.



Figure 4.4.9.a: Phase 2 HD vehicle to Ford Taurus crash simulation setup – three-quarter view

D3PLOT: ftt_c2c_tau27_100



Figure 4.4.9.b: Phase 2 HD vehicle to Ford Taurus crash simulation setup – side view

D3PLOT: ftt_c2c_tau27_100

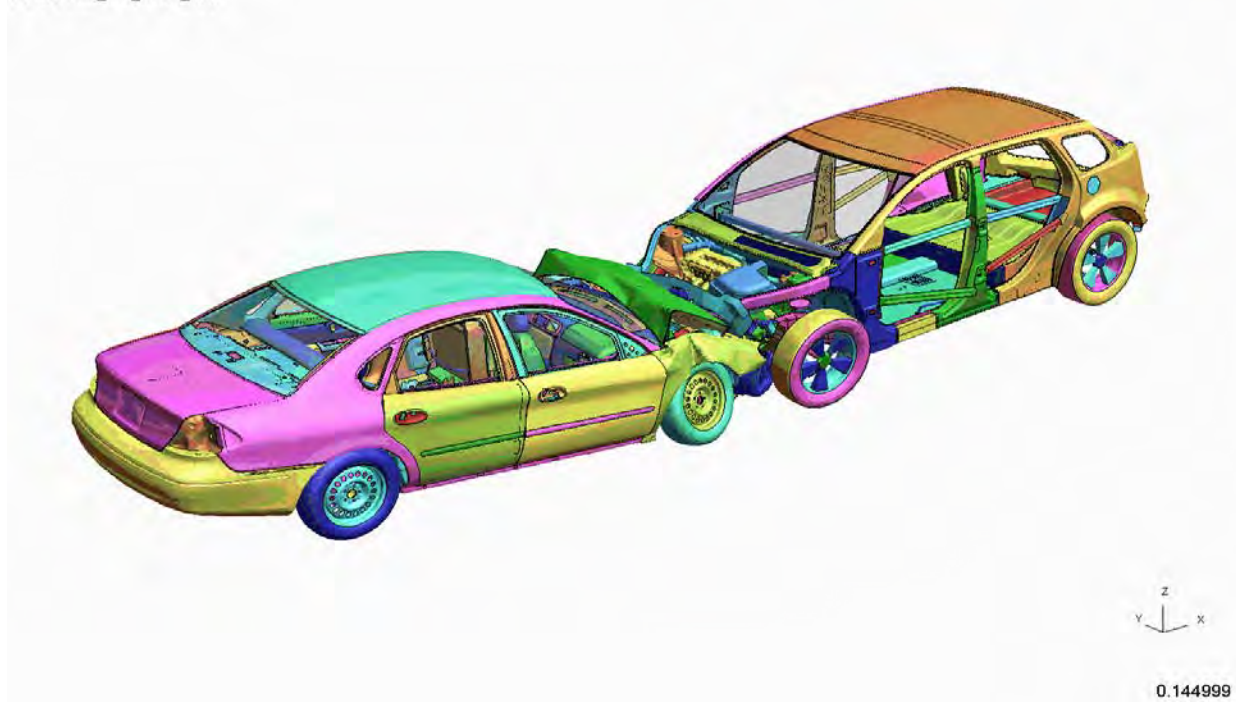

Figure 4.4.9.c: Phase 2 HD vehicle to Ford Taurus crash simulation result – three-quarter view

D3PLOT: frt_c2c_tau27_100

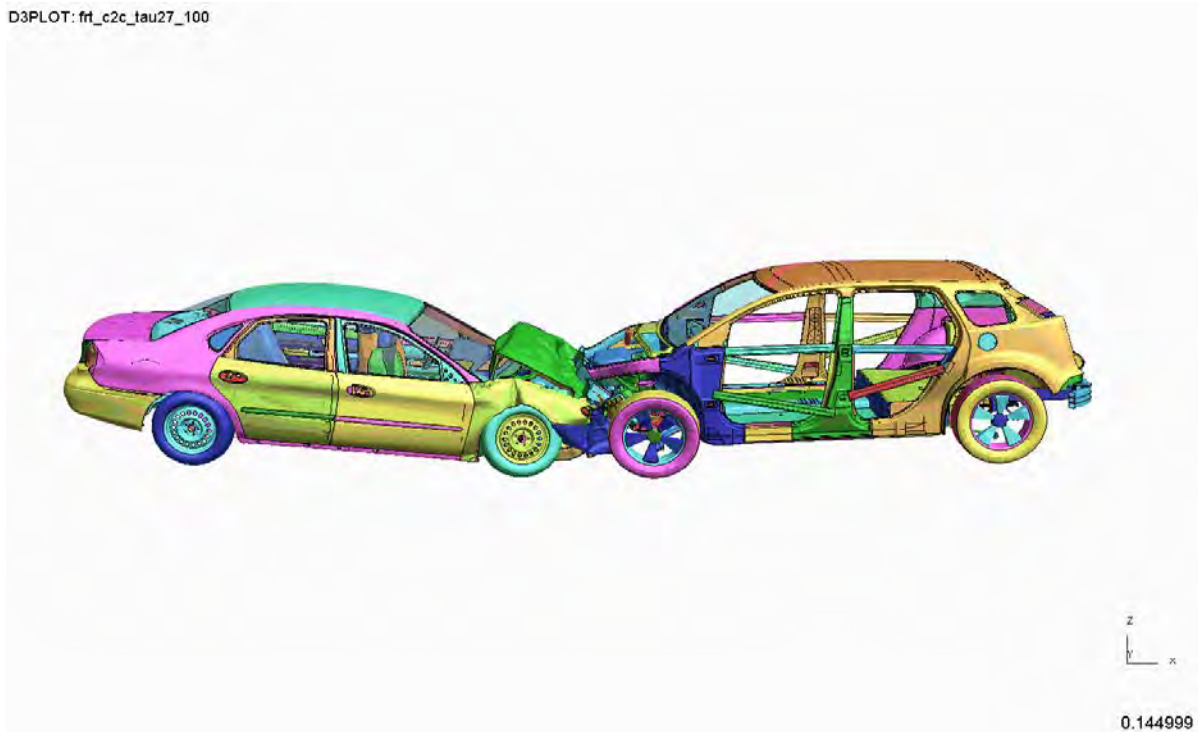

Figure 4.4.9.d: Phase 2 HD vehicle to Ford Taurus crash simulation result – side view

D3PLOT: frt_c2c_tau27_100

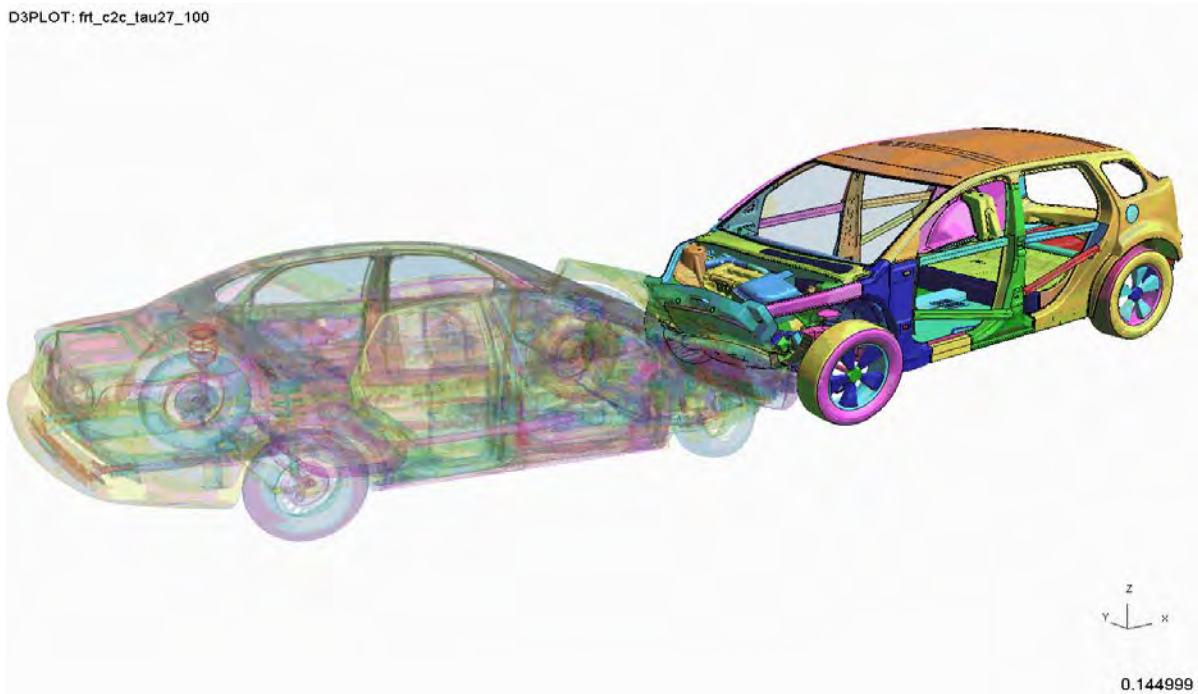

Figure 4.4.9.e: Phase 2 HD vehicle to Ford Taurus crash simulation result – three-quarter view, opaque Taurus

4.4.10. Summary of Safety Testing Results

Table 4.4.10.a below summarizes the findings from the above design, technical engineering analysis, and crash test simulations. The table reports specifically on the study's objectives to develop and evaluate a mass-reduced vehicle structure relative to known guidelines and requirements for crashworthiness – both governmental and voluntary testing, stiffness, and torsional bending. As part of Task 1, the mass-reduced Phase 2 vehicle model was evaluated for conformance to the existing external data for the baseline Toyota Venza, for torsional stiffness, and managing impact loads.

As part of Task 2, the mass-reduced vehicle model was evaluated relative to specified FMVSS requirements as well as the IIHS bumper tests (the IIHS side impact and front and rear crash tests were not part of the contract). All of the tests were conducted using CAE analyses and BIW acceleration and intrusion levels. These tests measure dummy occupant acceleration levels on a physical vehicle typically. Developing a full occupant restraint system and interior as well as building a physical test vehicle were beyond the scope of this project. Using vehicle intrusion and acceleration levels shows whether the vehicle has the potential to meet crash test requirements. As with any theoretical model, some changes may be required once a physical vehicle is built and tested.

Table 4.4.10.a: Summary of Vehicle Model Testing

| Area | Requirement, Guideline, Test | Result of Vehicle Simulation |
|---------------------|--|---|
| Model | Conformance with existing external data for the baseline Venza | Dimensions, interior volume, utility maintained |
| Standard Operating | Withstand and dampen major customary vehicle loads (e.g. running loads) | Analyses showed vehicle robustness |
| Development | Meet best-in-class torsional and bending stiffness | 32,900 N |
| Frontal Impact | Full frontal crash analysis: static stiffness (FMVSS 208) and compatibility of main body structure and front end energy absorption subsystem including 35-mph, 0-degree flat barrier; 25-mph, 30-degree flat barrier; 25-mph, 40-percent offset deformable barrier | Acceptable intrusion and acceleration levels |
| | IIHS bumper: 6-mph centerline, 3-mph, 15-percent offset | Acceptable strain levels |
| Side Impact | Side impact, door beam intrusion testing (FMVSS 214) including 35-mph, 27-degree moving deformable barrier; 20-mph, 75-degree pole impact | Acceptable intrusion and acceleration levels |
| Rear Impact | Rear impact, moving deformable barrier (FMBSS 301) | Acceptable intrusion and acceleration levels |
| | IIHS bumper: 6-mph centerline, 3-mph, 15-percent offset | Acceptable strain levels |
| Rollover Protection | Roof crush (FMVSS 216) | Acceptable intrusion levels |
| Restraint Systems | Seatbelt anchorages (FMVSS 210) | Acceptable deformation levels |

| | | |
|----------------------------|---|--|
| | Child restraint systems (FMVSS 213) | Acceptable deformation levels |
| Vehicle Structure | Front and rear energy management, non-deformation, and chassis frame buckling testing | Acceptable acceleration, intrusion, and deformation levels |
| Vehicle-to-Vehicle Impacts | 35-mph, car-to-car impact with NCAC Ford Taurus; Taurus velocity: 27 mph | Acceptable acceleration and intrusion levels |
| | 35-mph, car-to-car impact with NCAC Ford Explorer; Explorer velocity: 18 mph | Acceptable acceleration and intrusion levels |

4.5. Closures

The analyses presented heretofore included only simulated door beams (see section 4.2.1.2) for FEA analysis. ARB contracted Lotus Engineering Inc. to determine the effect fully engineered closures would have on vehicle crash performance. The results of developing closures are presented in this section.

4.5.1. Objectives

The objectives of this set of analyses were to evaluate the vehicle performance with the addition of closures (hood, doors, tailgate, and fenders); with the updates to the BIW (revised upper A-pillar/cowl/front header – changed as a result of the stiffness studies; and location of the rear bumper armature (translated rearwards to improve the IIHS low speed performance).

The updated model was run using the same load cases as the previous model (as listed below).

- FMVSS 208: Front Impact (0°/30° rigid wall, offset deformable barrier)
- FMVSS 210: Seat Belt Anchorages
- FMVSS 213: Child Restraint Systems
- FMVSS 214: Side Impact (side barrier, side pole)
- FMVSS 216: Roof Crush
- FMVSS 301: Rear Impact (moving deformable barrier)
- IIHS: Low Speed Bumper (front & rear)

The changes made did not have a major impact on the front impact performance or occupant related load cases. Therefore the vehicle performance already reported for FMVSS 208 is still valid.

This report details the results from the side impact, rear impact, and roof crush load cases only.

4.5.2. Model Updates

The previous CAE model was updated with CAD data that was supplied for the following:

Hood Assembly
Tailgate Assembly
Front and Rear Door Assembly
Fenders and Mounting brackets
BIW Component Updates
Rear Bumper Armature Assembly

Figure 4.5.2.a. highlights the images of the main updated components only.

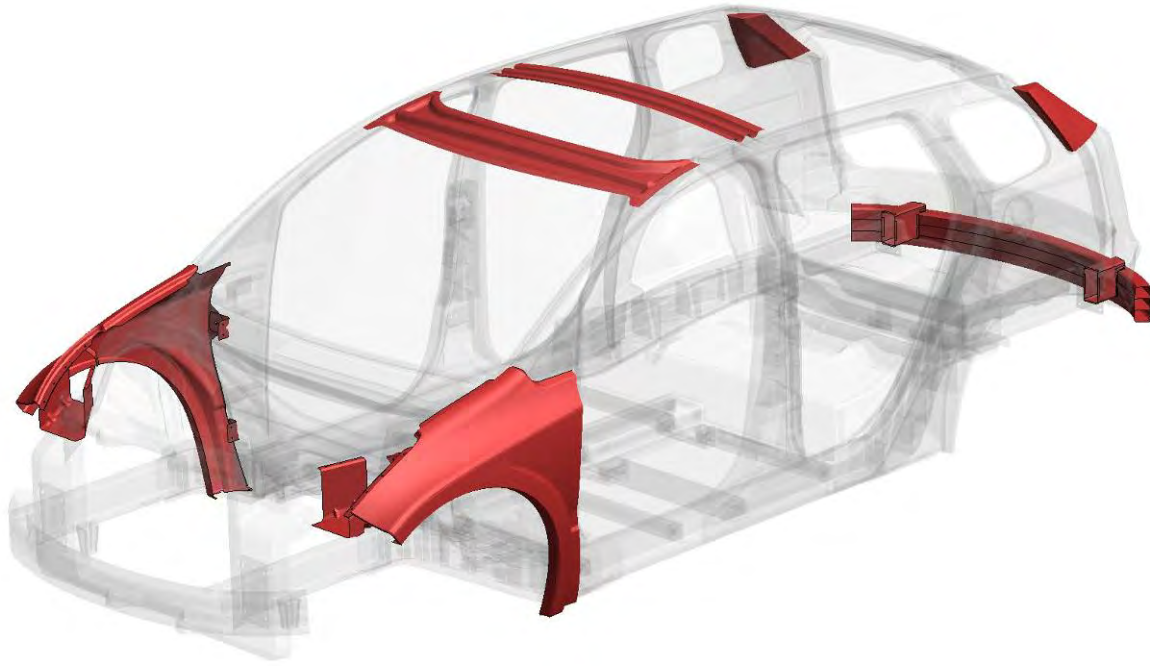

Figure 4.5.2.a: Body-in-White – V27

Figures 4.5.2.b and 4.5.2.c below shows front and rear isometric views of the closure systems added to the BIW model. The hood was modeled with local reinforcements for the hinge and latch system (not shown) for V27.

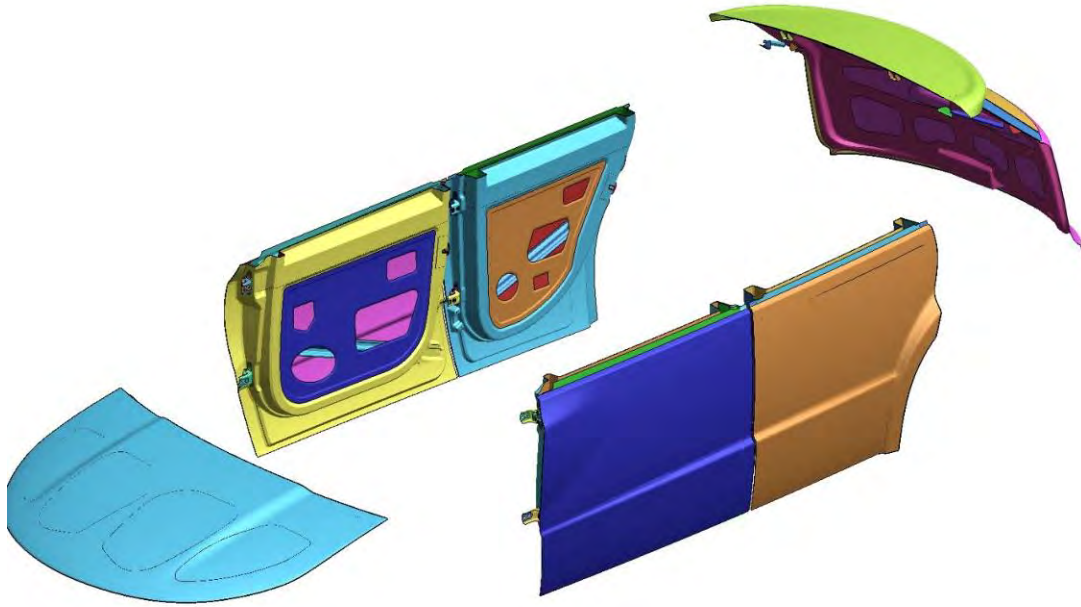

Figure 4.5.2.b: Front closure view

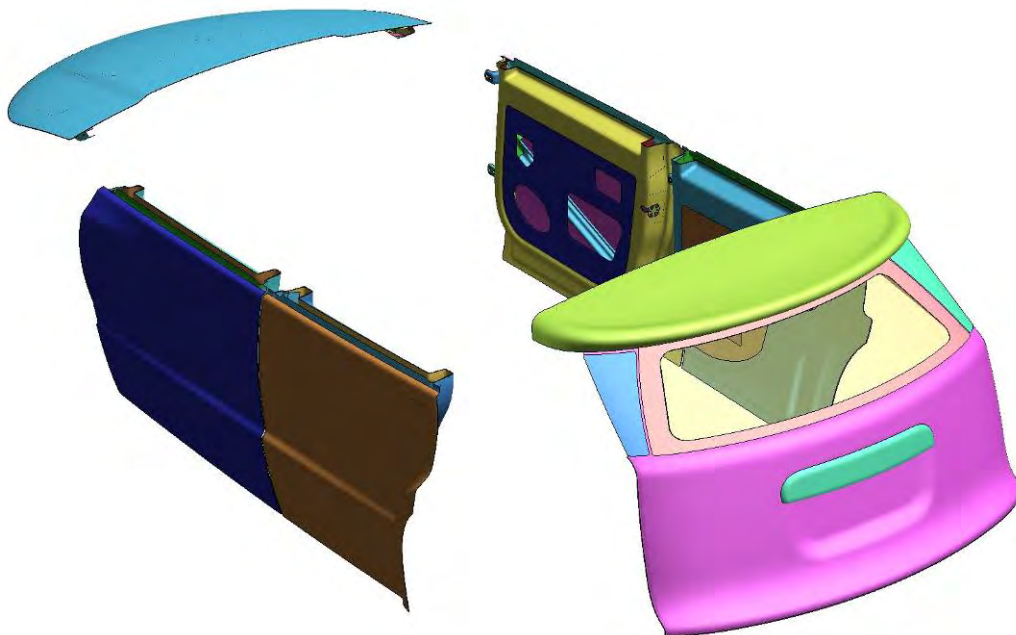

Figure 4.5.2.c: Rear closure view

4.5.3. Model Mass/Other Information

Total model weight for the V27 update was increased by 23.34 kg to a curb weight of 1173.34kg vs. the V26 model primarily due to the increased mass of the body in white which used a higher percentage of aluminum and less magnesium than the Phase 1 BIW.

4.5.4. Analysis Results

The following sections show analysis results from crash tests that would be significantly affected by the changes made to the CAE model (V26) in previous sections. This new model with fully engineered closures is referred to as V27.

4.5.4.1. 33.5-mph Side Impact – Crabbed Barrier

Previously a representation of the door beams and the hinge and latch reinforcements had been included. With the inclusion of the closure in the model it is possible to monitor the intrusion of the door inner structure under this load case. The FMVSS214 test is a requirement where the pass/fail is determined on occupant injury so would require door trim and the restraints to be modeled for correctness. To ensure that the side airbag could deploy unhindered the door intrusion velocity and displacement is monitored. Figure 4.5.4.1.a shows the model setup with the barrier in place.

D3PLOT: side_fmvs214_mdbleh33p5

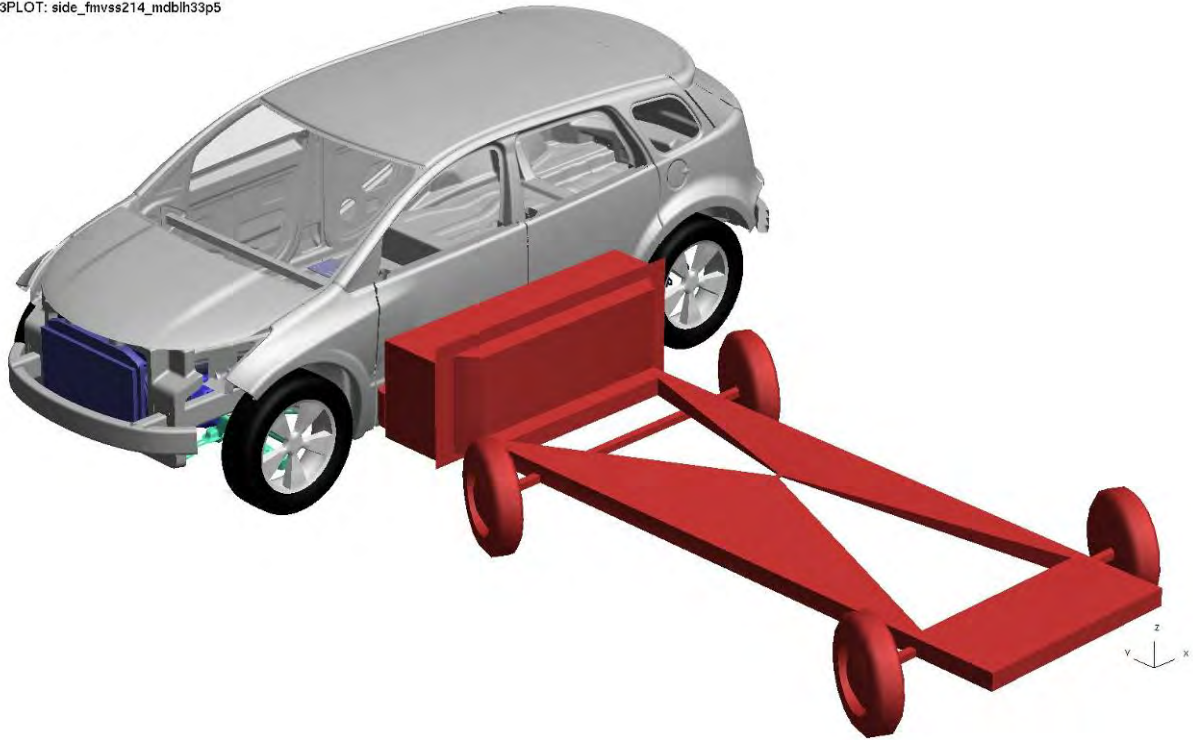

Figure 4.5.4.1.a: Model analysis setup

Figures 4.5.4.1.b and 4.5.4.1.c below show the vehicle deformation following impact.

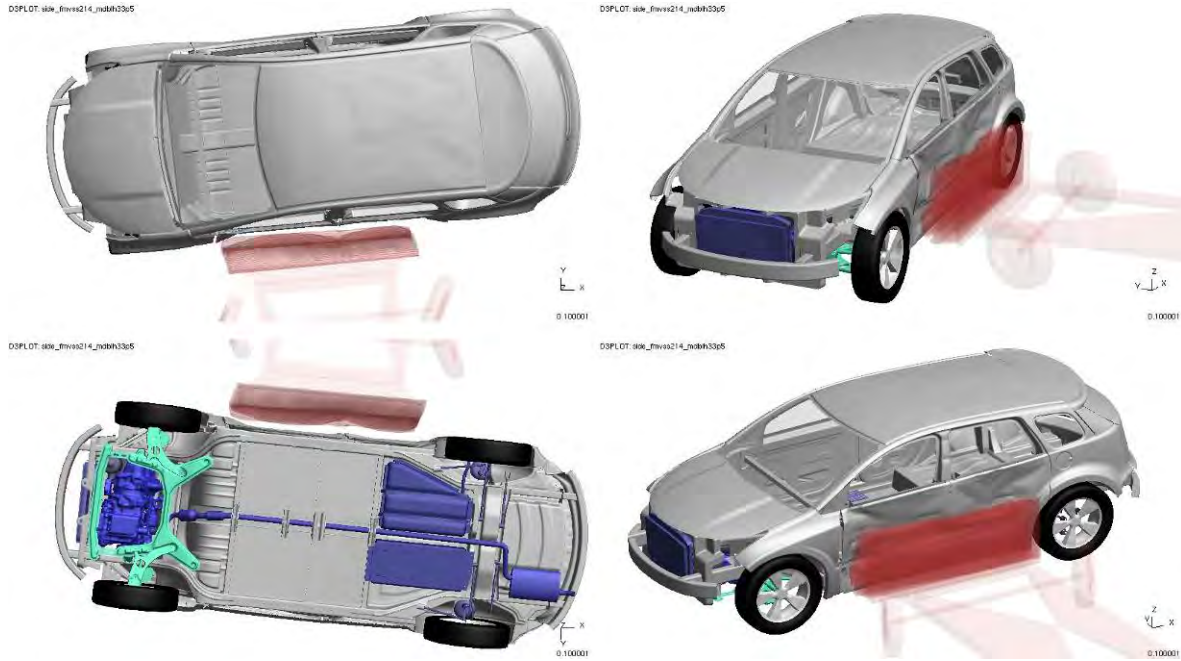

Figure 4.5.4.1.b: Vehicle Deformation (0.1s)

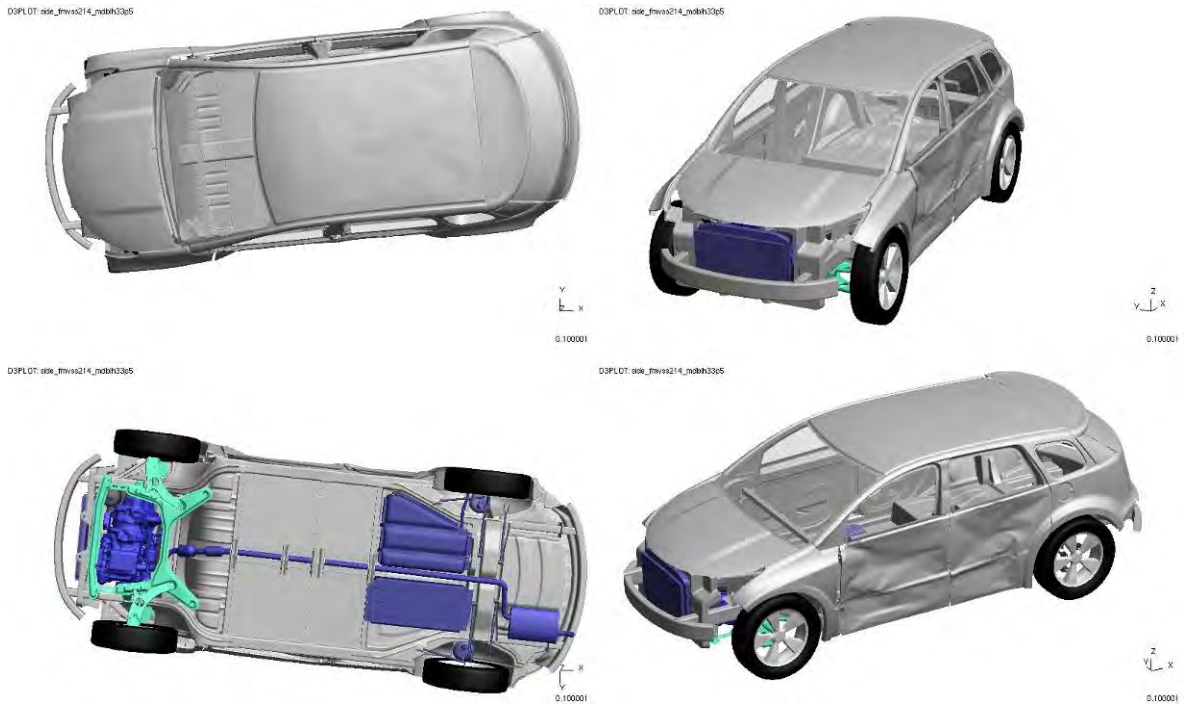

Figure 4.5.4.1.c: Vehicle Deformation (barrier not shown)

Figures 4.5.4.1.d and 4.5.4.1.e show the vehicle and barrier velocities and the B pillar relative intrusion velocities.

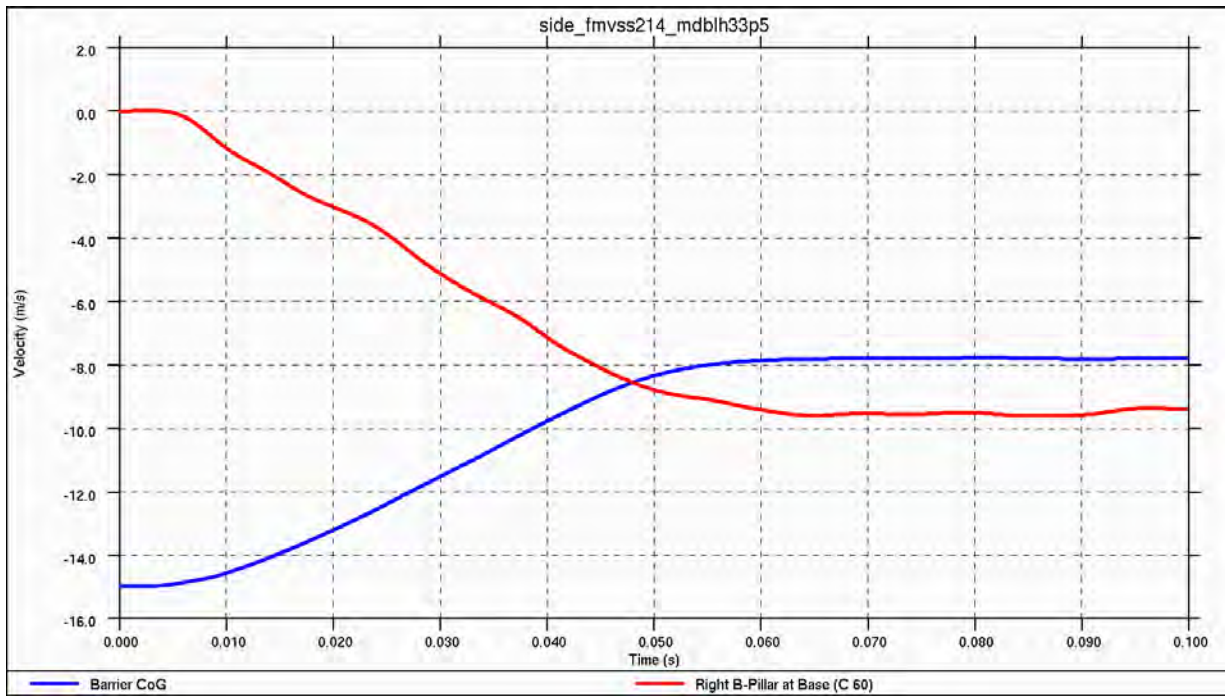

Figure 4.5.4.1.d: Global Vehicle and Barrier Velocities

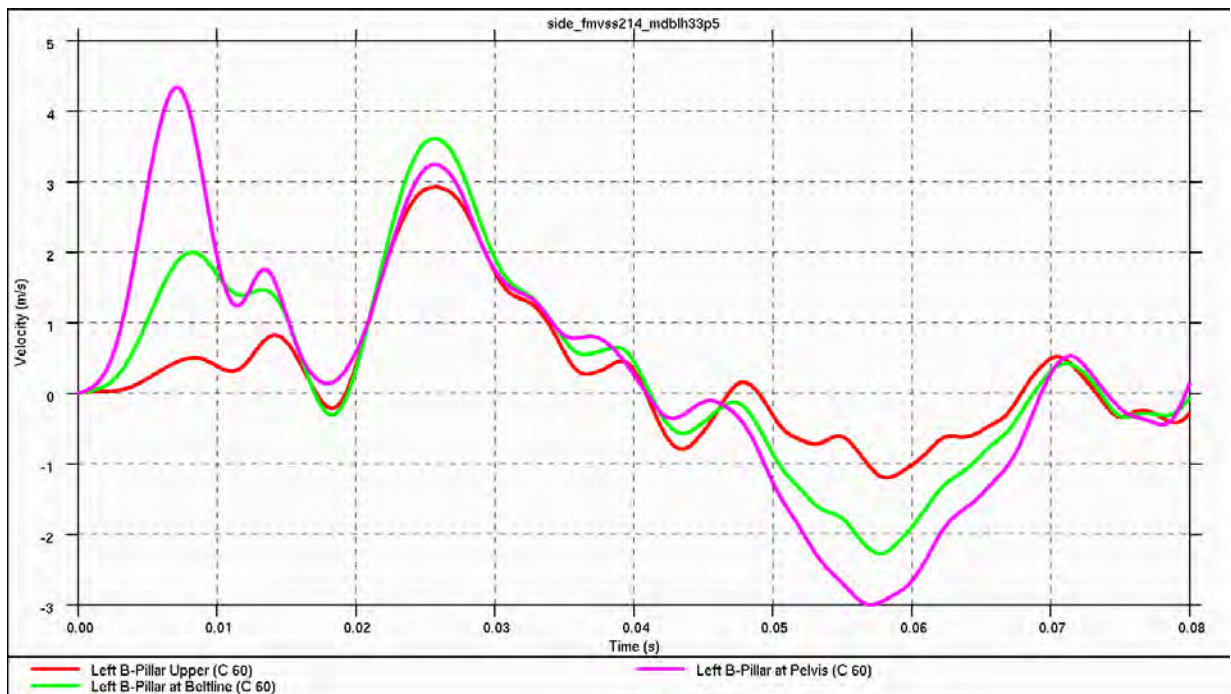

Figure 4.5.4.1.e: Relative Intrusion Velocities (B-pillar)

Figures 4.5.4.1.f and 4.5.4.1.g show the B pillar and the front/rear door intrusion displacements.

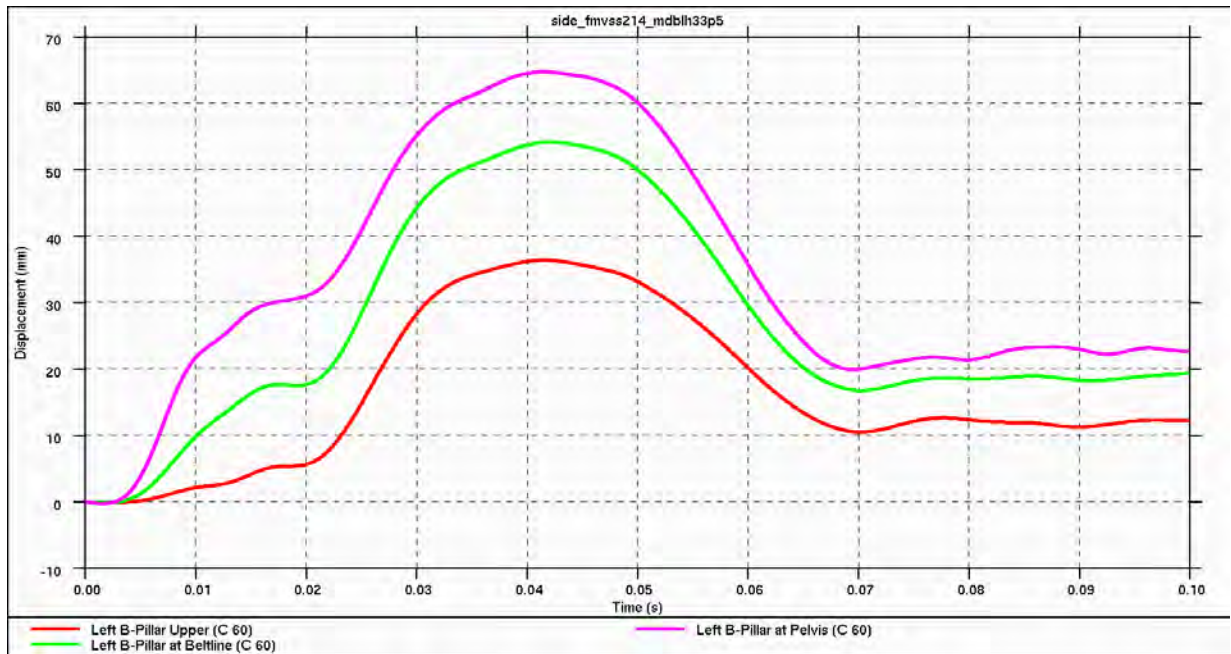

Figure 4.5.4.1.f: Relative Intrusion Displacements (B-pillar)

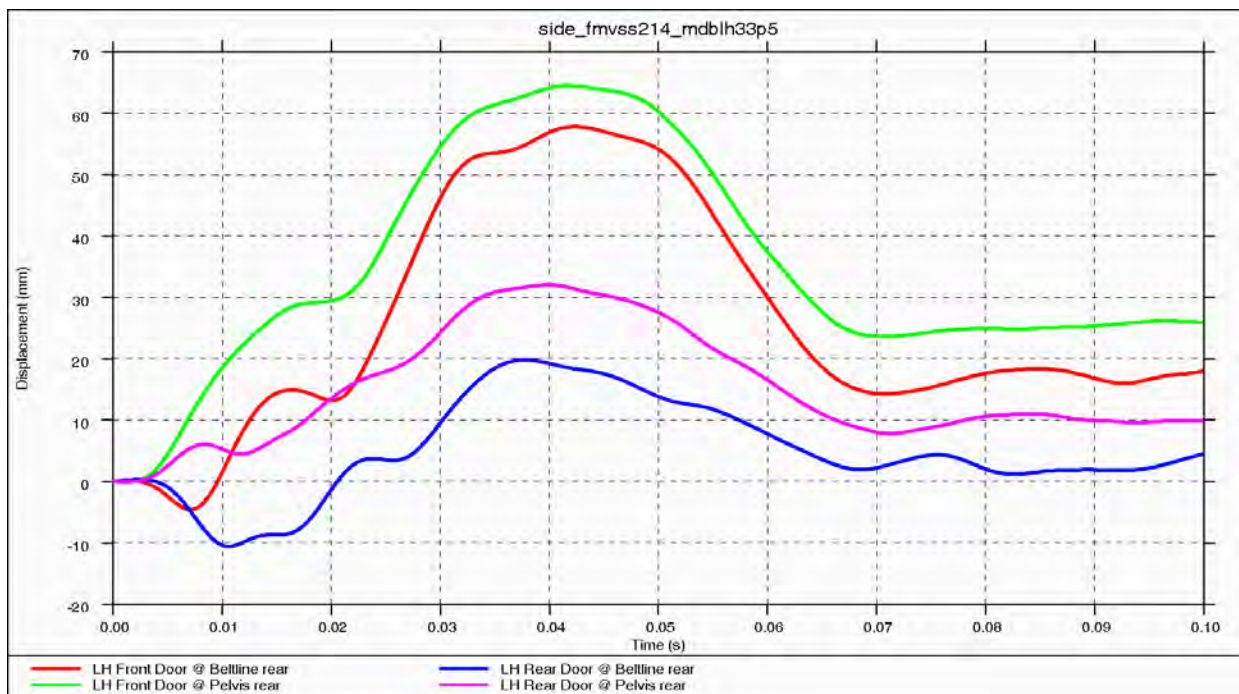

Figure 4.5.4.1.g: Relative Intrusion Displacements (Front/Rear Door)

Figure 4.5.4.1.h shows the intrusion for the B pillar at the B-pillar centerline.

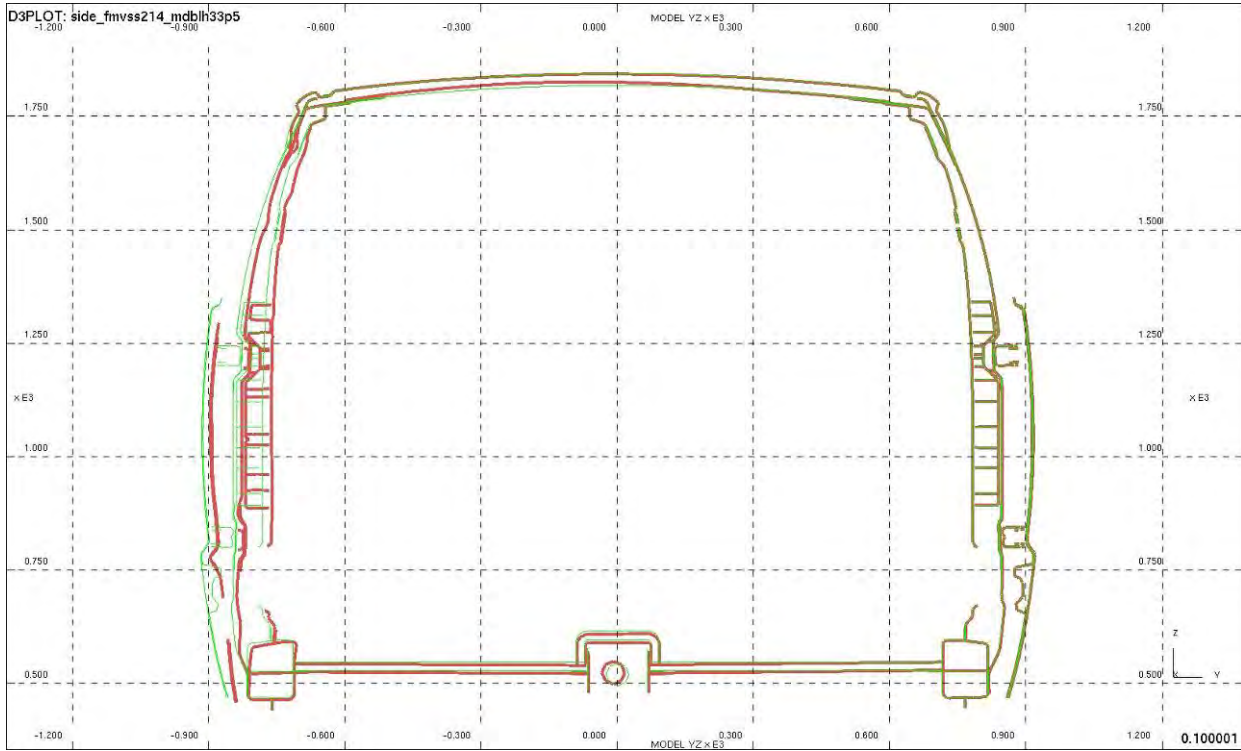

Figure 4.5.4.1.h: B-Pillar Intrusion profile $x=2842$

Figure 4.5.4.1.i shows the intrusion displacements for the struck side of the car.

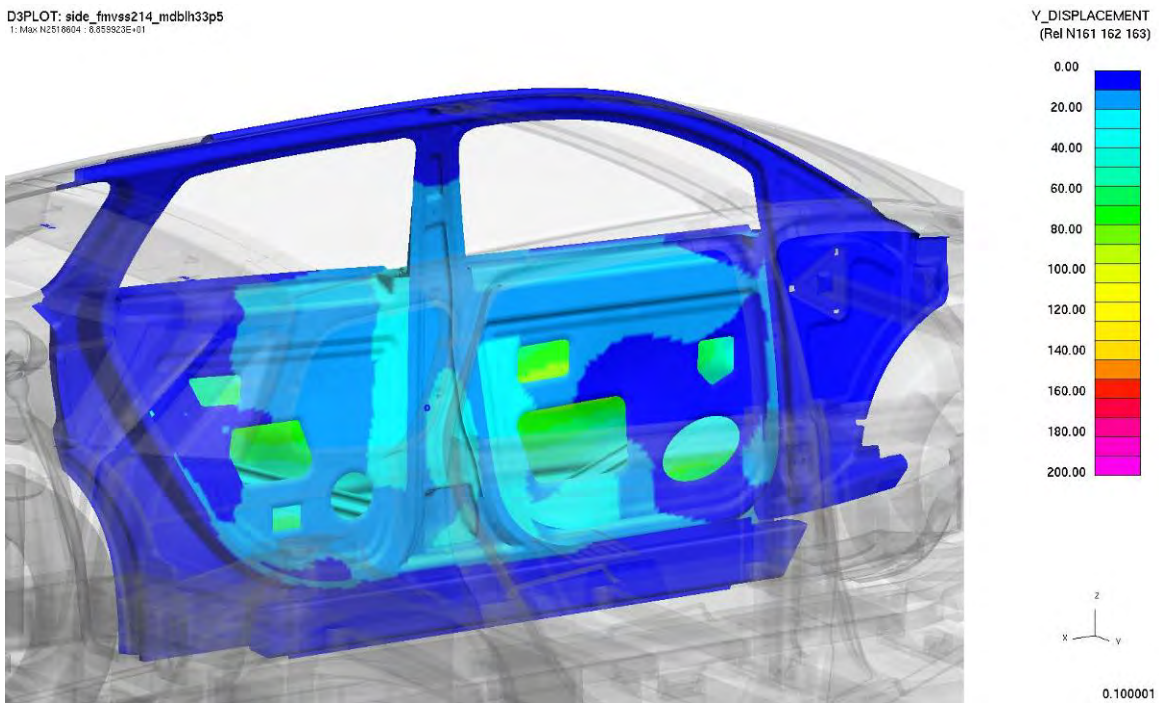

Figure 4.5.4.1.i: Intrusion levels on Struck-side

Figure 4.5.4.1.j shows the plastic strain for the struck side of the car.

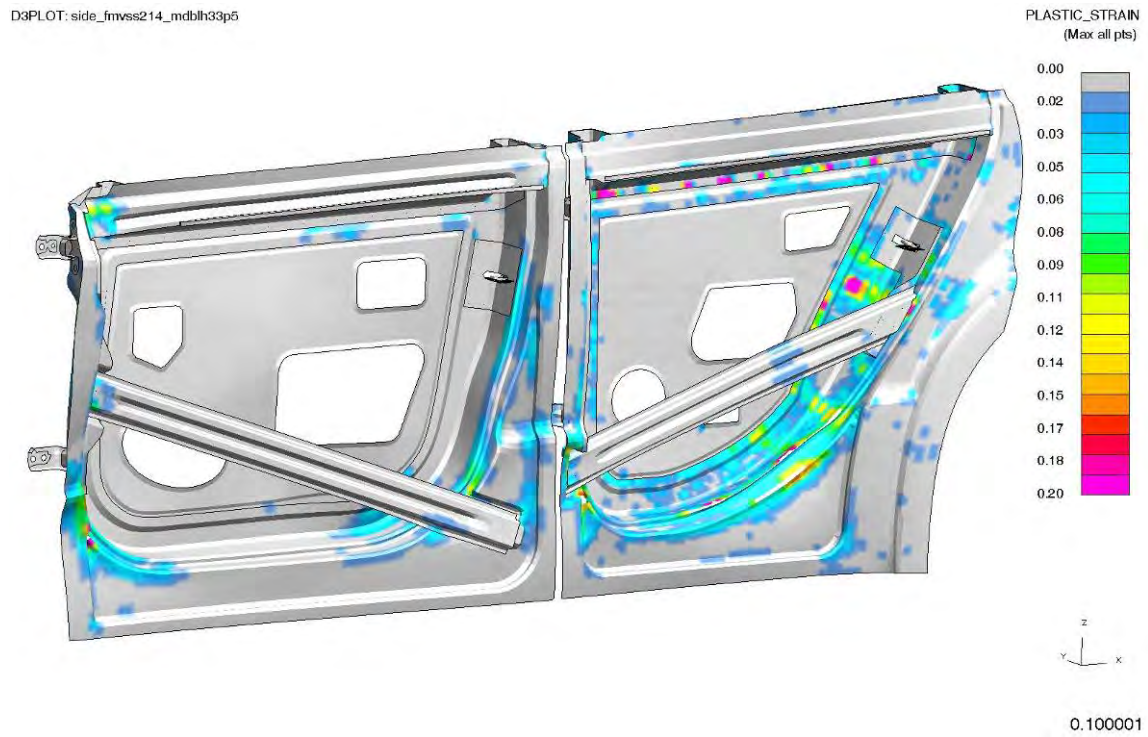

Figure 4.5.4.1.j: Plastic Strain in Struck-side Doors

Figure 4.5.4.1.k shows the energy balance for the struck side of the car.

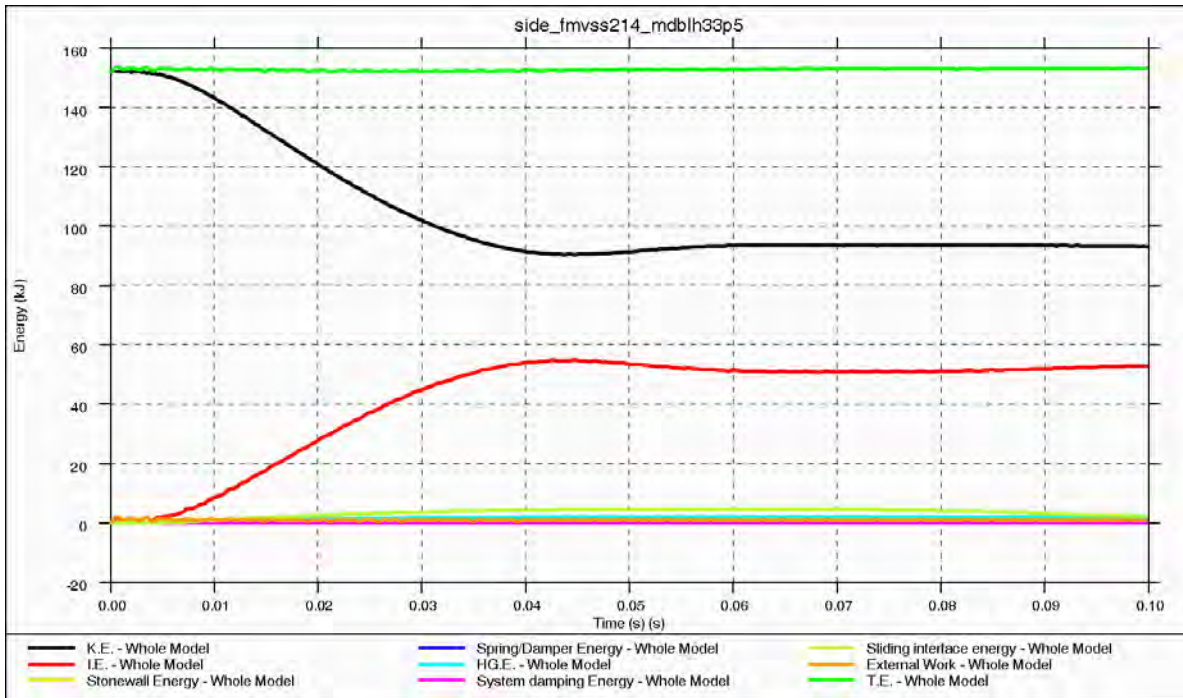

Figure 4.5.4.1.k: Energy Balance

4.5.4.1.1. Observations - Side Impact MDB

With the inclusion of the doors into the CAE model the time for the cross-over velocity (vehicle is moving with same velocity as barrier) occurs at 48ms. This is 17ms earlier than without the closures. This indicates that the vehicle side impact performance is stiffer than previous analyses predicted.

The intrusion velocity of the B-Pillar is also predicted to have reduced slightly.

The intrusion of the B-Pillar into the vehicle during impact is predicted to be 65mm, which is a 15mm improvement over the previous (#26) model or a reduction of 19% vs. the original model. The maximum intrusion of the door inner panel is also predicted to be 65mm maximum. This maximum occurs at the approximate z-height location with the pelvis of the dummy.

One of the reasons for the minimal predicted intrusion under this load case is the location of the door intrusion beams. These have been located such that there is an overlap with the B-Pillar which means that when it is loaded in side impact it becomes trapped between the barrier and the B-Pillar. The B pillar uses hot stamped boron steel material which has extremely high yield strength. This means that it has more elastic deformation capability than regular steel (i.e. HSLA). Note that elastic deformation will absorb more energy (per unit displacement) than plastic deformation. At the forward location of the rear door intrusion beam attachment to the door inner panel, the analysis predicts that there is material failure of the cast magnesium inner.

With these improved results predicted by the analysis, the ability for the occupant restraints system to work should not be compromised by the body structure.

4.5.4.2. 20mph 75° Side Pole Impact – Front (5th Percentile Female)

The FMVSS214 20mph 75degree pole load case is carried out with a rigid pole lined up with the occupant head center-of-gravity location (2590.5x/-393.8y) along the direction of travel. It is carried out with a 5th %ile female dummy and a 50th %ile male dummy. As the two dummies put the seat in two different locations the initial impact points are different, requiring two separate analyses be performed.

As with the moving barrier impact case, the requirement is to monitor the injury of the occupants. This analysis would be carried out on a full vehicle with closures, dummies, interior and a restraints system. The updated model (#27) includes the closures so their response (intrusion levels and velocities) can also be evaluated. Figure 4.5.4.2.a shows the model setup.

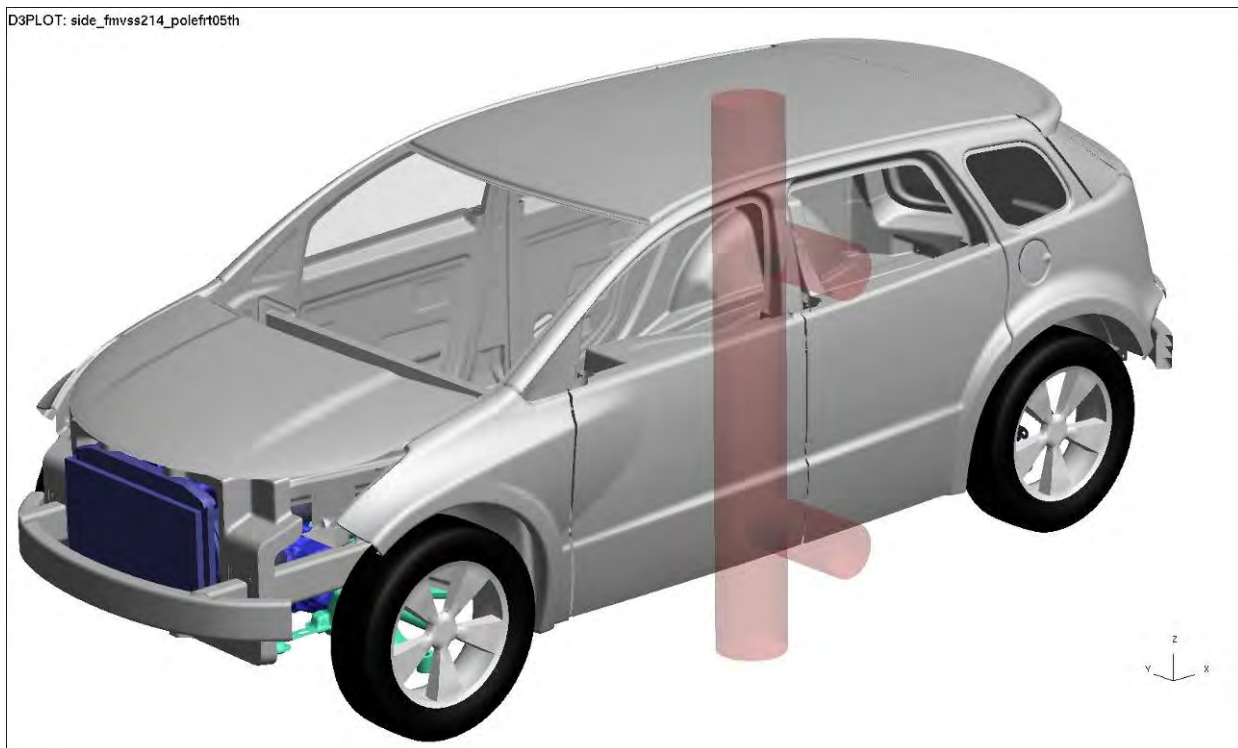

Figure 4.5.4.2.a: 20-mph, 75-degree side-pole impact -- front (5th percentile female) model setup

Figures 4.5.4.2.b and 4.5.4.2.c show the vehicle deformation following the pole strike.

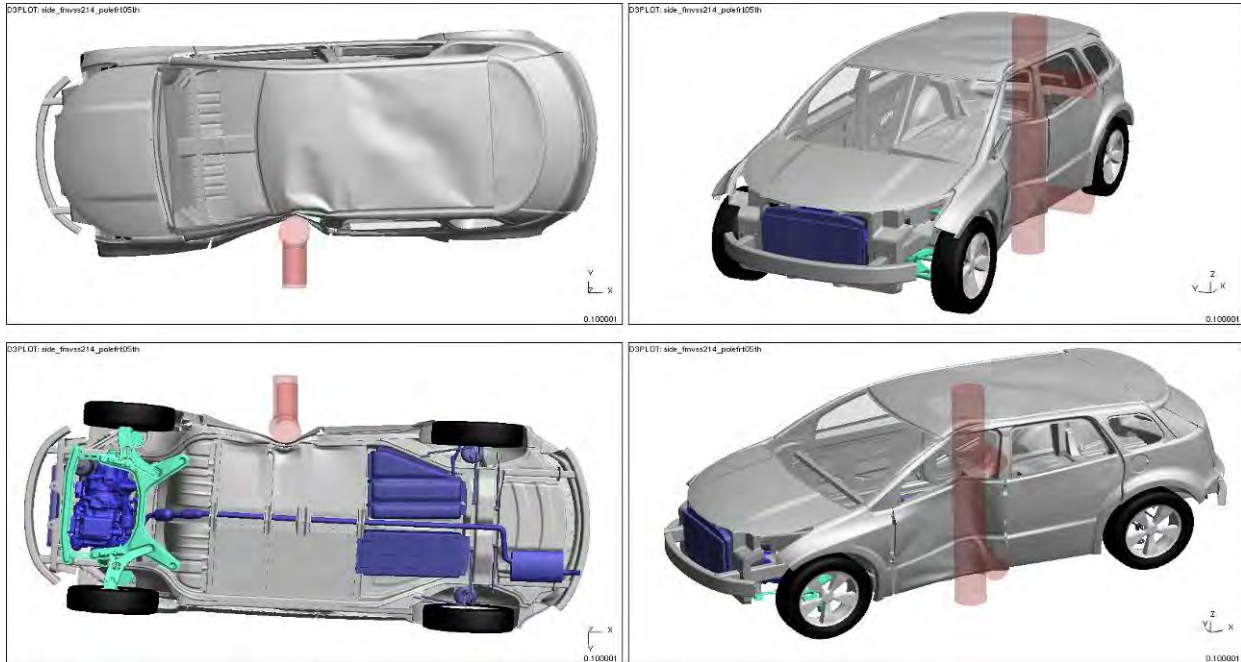

Figure 4.5.4.2.b: Vehicle Deformation (0.1s)

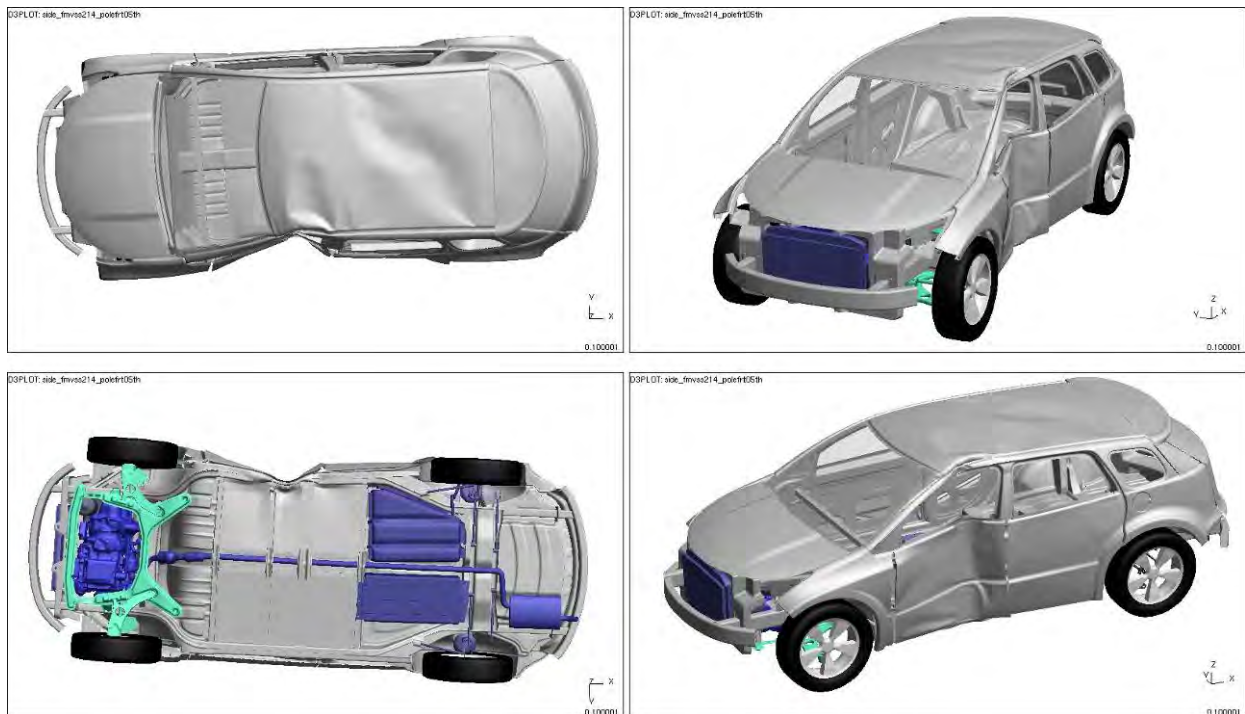

Figure 4.5.4.2.c: Vehicle deformation from 20-mph, 75-degree side-pole impact -- front (5th percentile female, pole blanked)

Figures 4.5.4.2.d and 4.5.4.2.e show the intrusion velocities and displacements for the B pillar and front door.

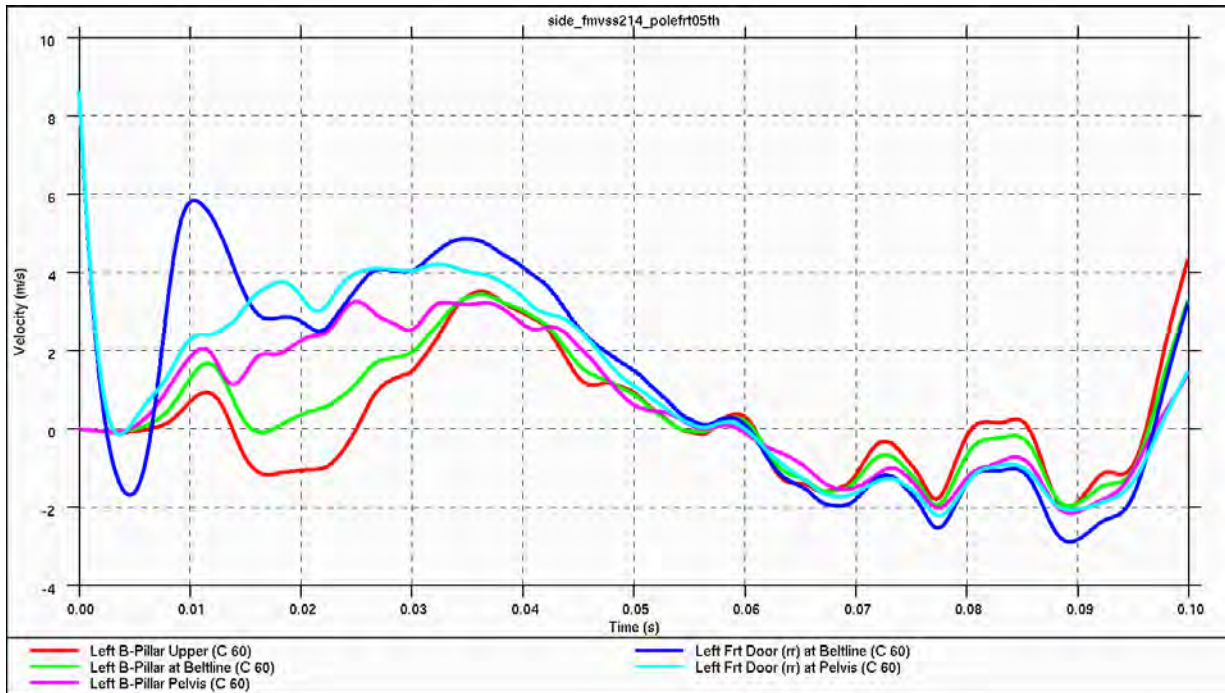

Figure 4.5.4.2.d: Intrusion Velocities (B-Pillar & Front Door)

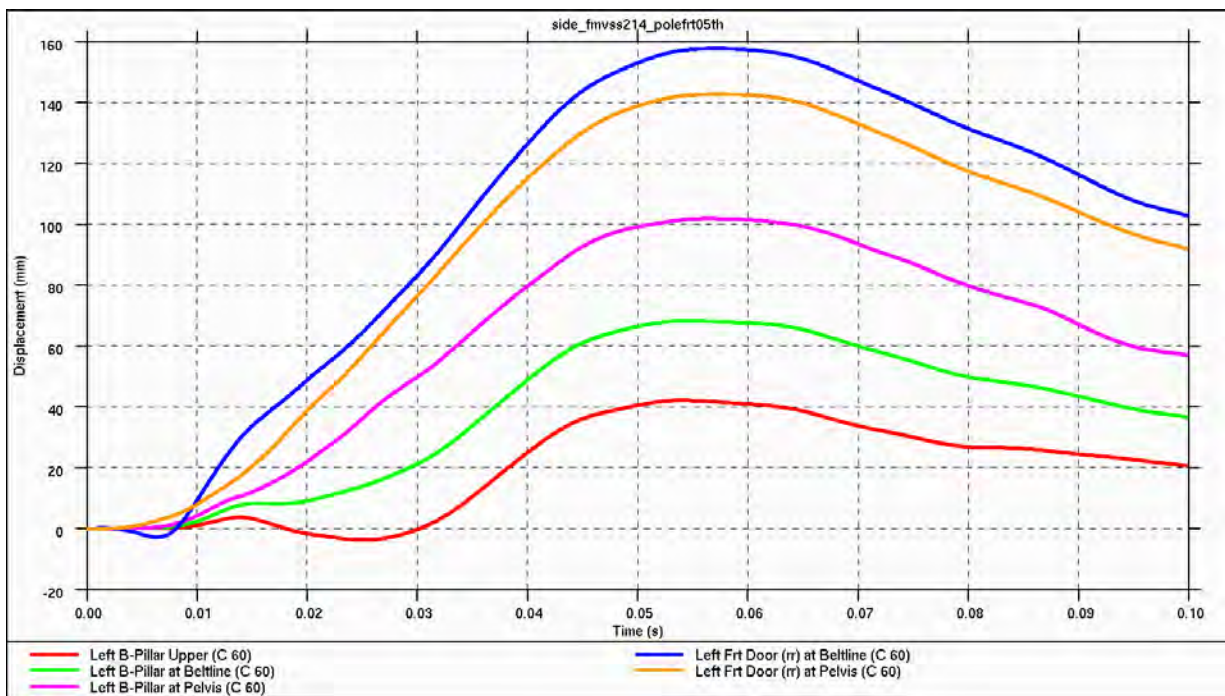

Figure 4.5.4.2.e: Intrusion Displacements (B-Pillar& Front Door)

Figure 4.5.4.2.f shows the intrusion levels at the centerline of the B pillar.

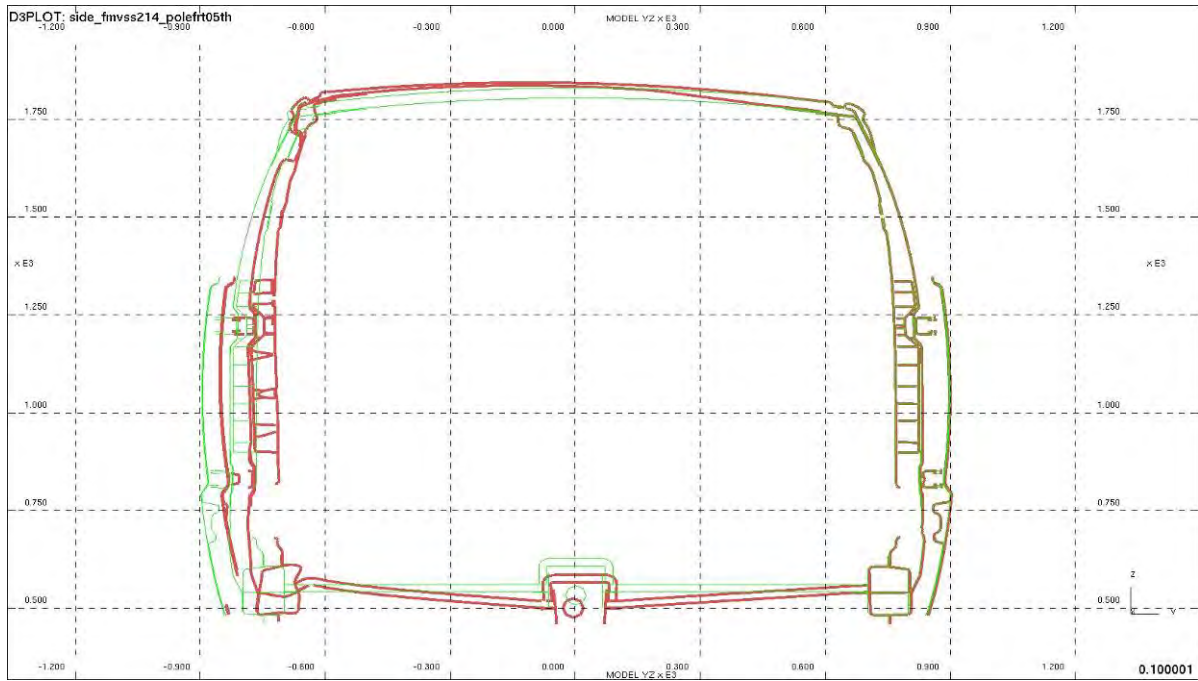

Figure 4.5.4.2.f: Section through B-Pillar, x= 2842

Figure 4.5.4.2.g shows the intrusion levels for the struck side of the front door.

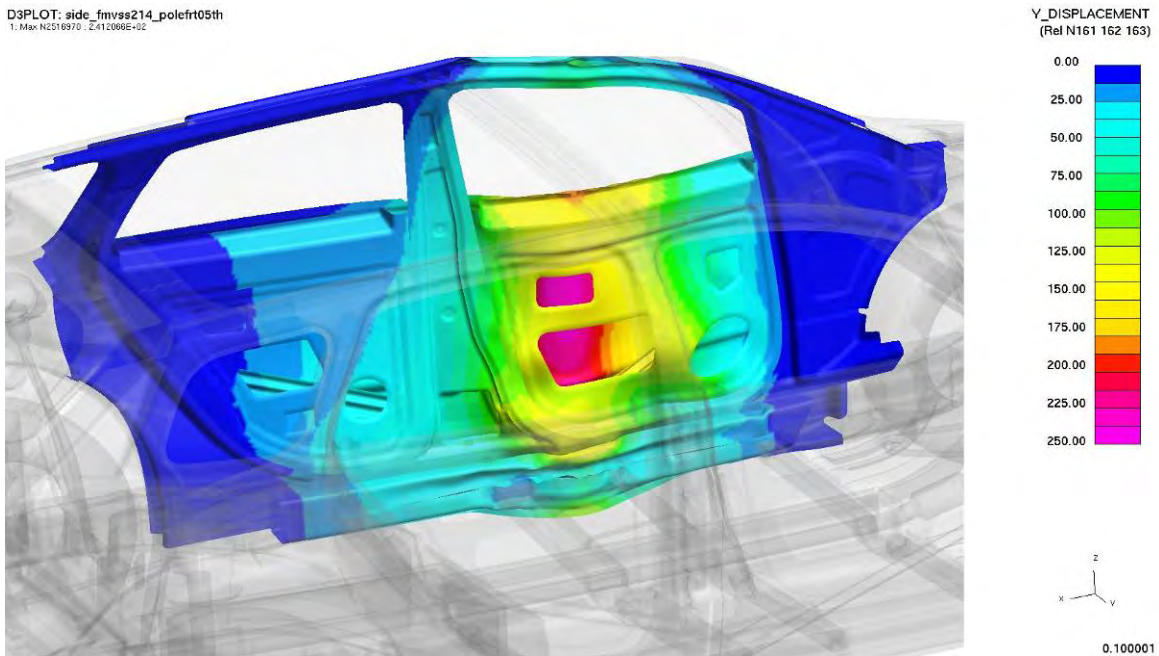

Figure 4.5.4.2.g: Intrusion levels on struck side

Figure 4.5.4.2.h shows the energy balance for the struck side of the front door. The energy balance show the analysis is valid as the overall energy of the crash is conserved.

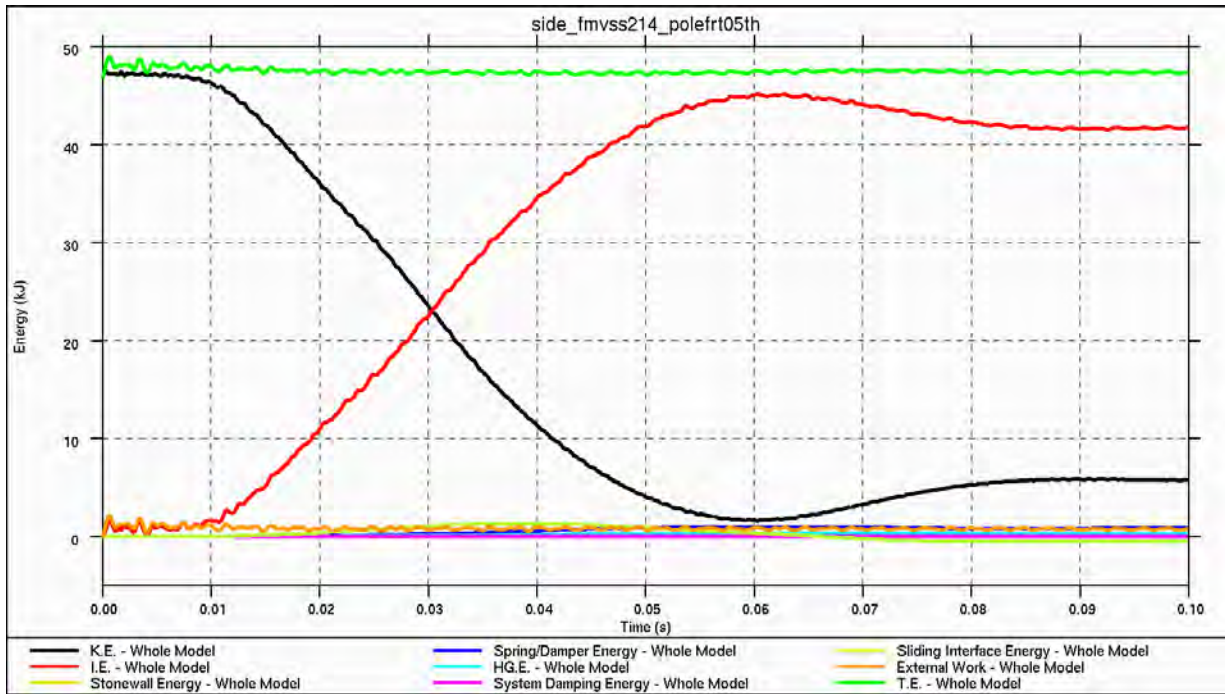

Figure 4.5.4.2.h: Energy Balance

4.5.4.3. 20-mph 75° Side Pole Impact – Front (50th percentile Male)

The FMVSS214 20-mph, 75-degree pole load-case for the male seating position will put the initial pole contact point further rearwards (179.5mm) in vehicle than for the 5th percentile female. Figure 4.5.4.3.a shows the model set-up.

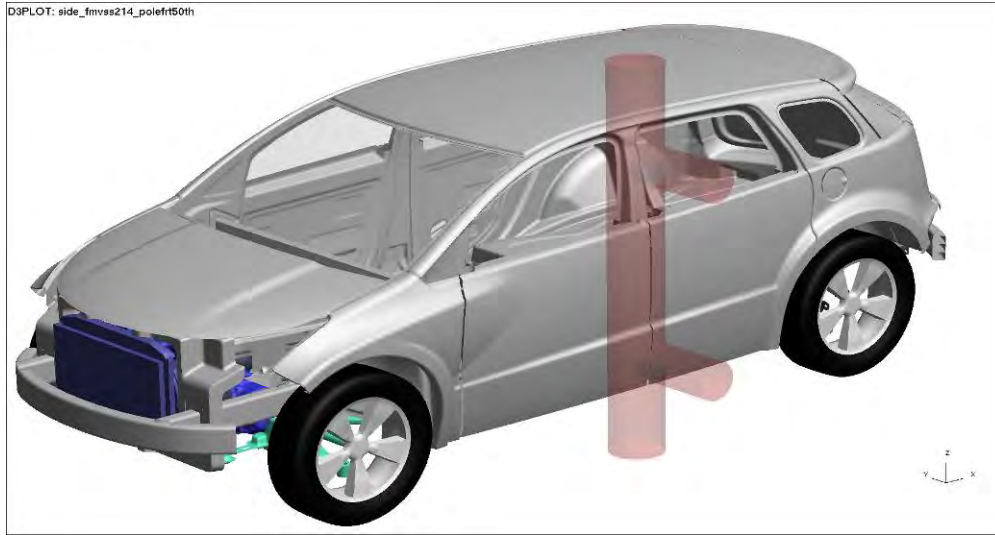

Figure 4.5.4.3.a: 20-mph, 75-degree side-pole impact -- front (50th percentile male) model setup

Figures 4.5.4.3.b and 4.5.4.3.c show the vehicle deformation after impact.

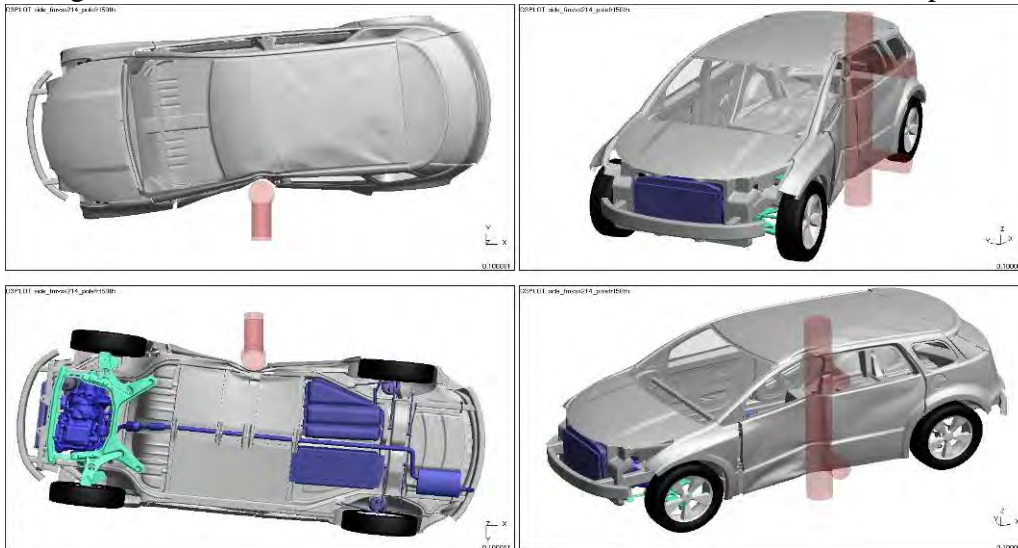

Figure 4.5.4.3.b: Vehicle Deformation (0.1s) after impact

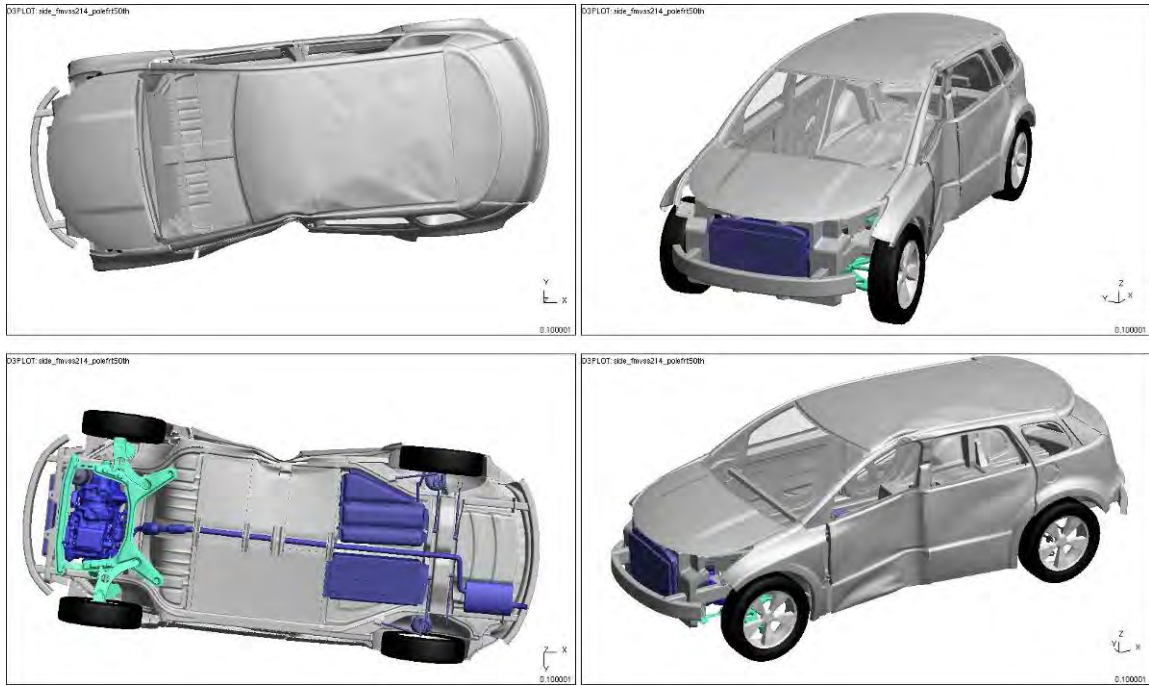

Figure 4.5.4.3.c: Vehicle Deformation (Pole Blanked)

Figures 4.5.4.3.d and 4.5.4.3.e show the intrusion velocities and displacements for the front door and B pillar.

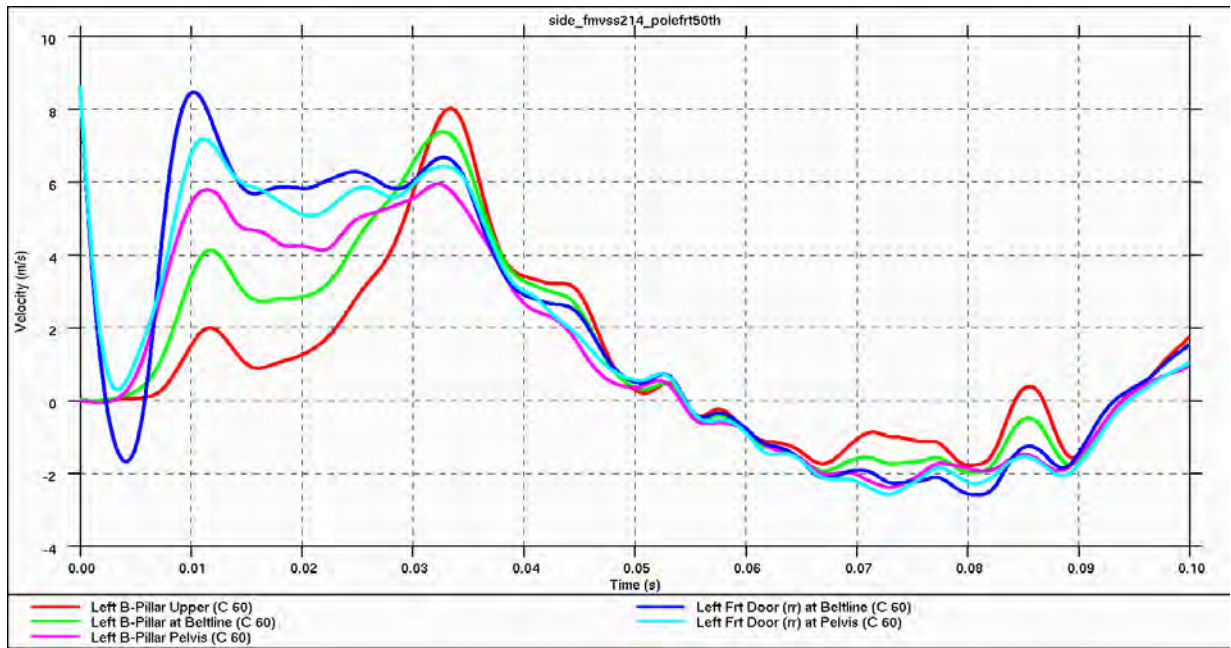

Figure 4.5.4.3.d: Intrusion Velocities (B-Pillar & Front Door) after 20-mph, 75-degree side-pole impact -- front (50th percentile male)

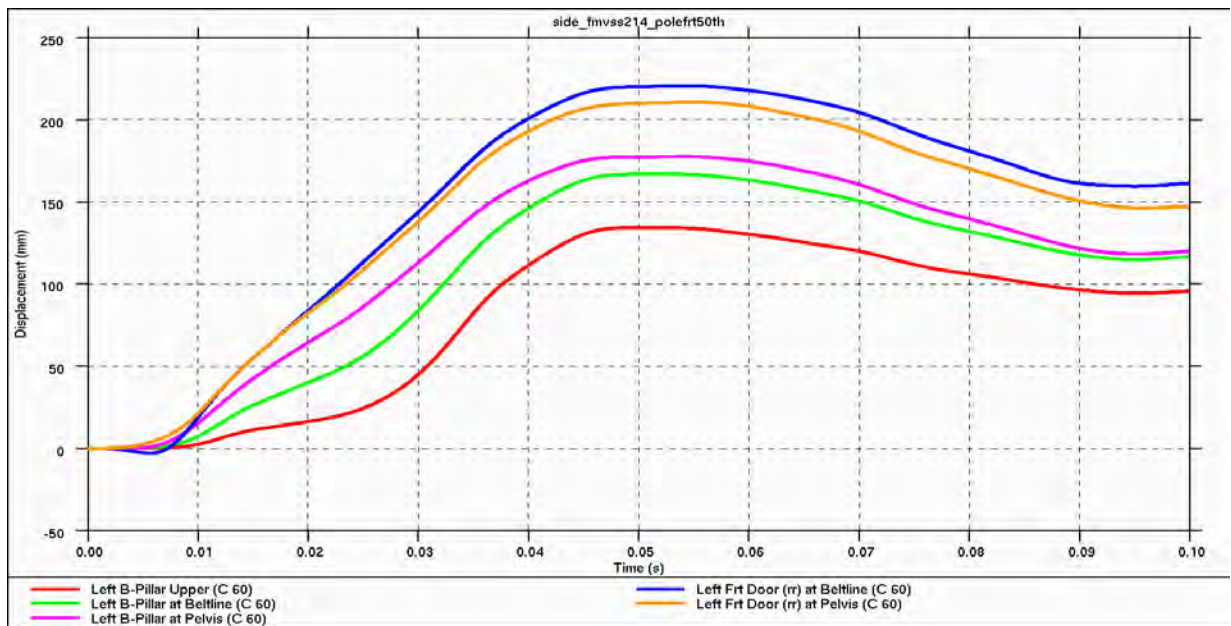

Figure 4.5.4.3.e: Intrusion Displacements (B-Pillar & Front Door) after 20-mph, 75-degree side-pole impact -- front (50th percentile male)

Figures 4.5.4.3.f and 4.5.4.3.g show the intrusion displacements for the front door and at the centerline of the B pillar.

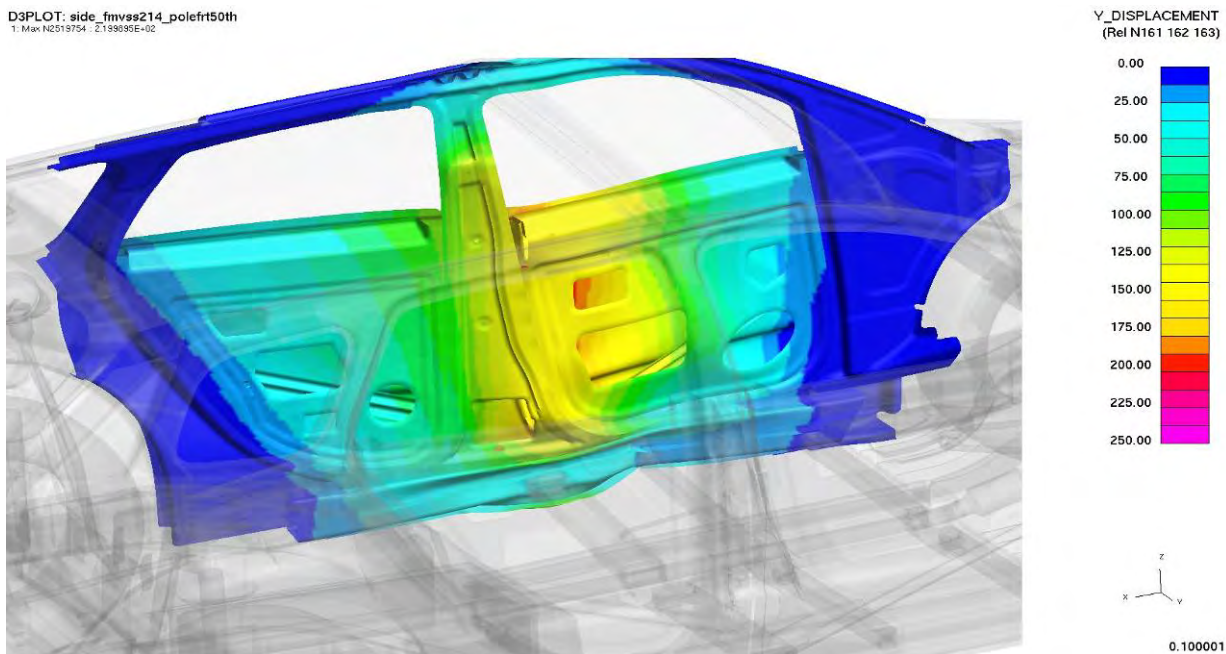

Figure 4.5.4.3.f: Intrusion levels on struckside after 20-mph, 75-degree side-pole impact - front (50th percentile male)

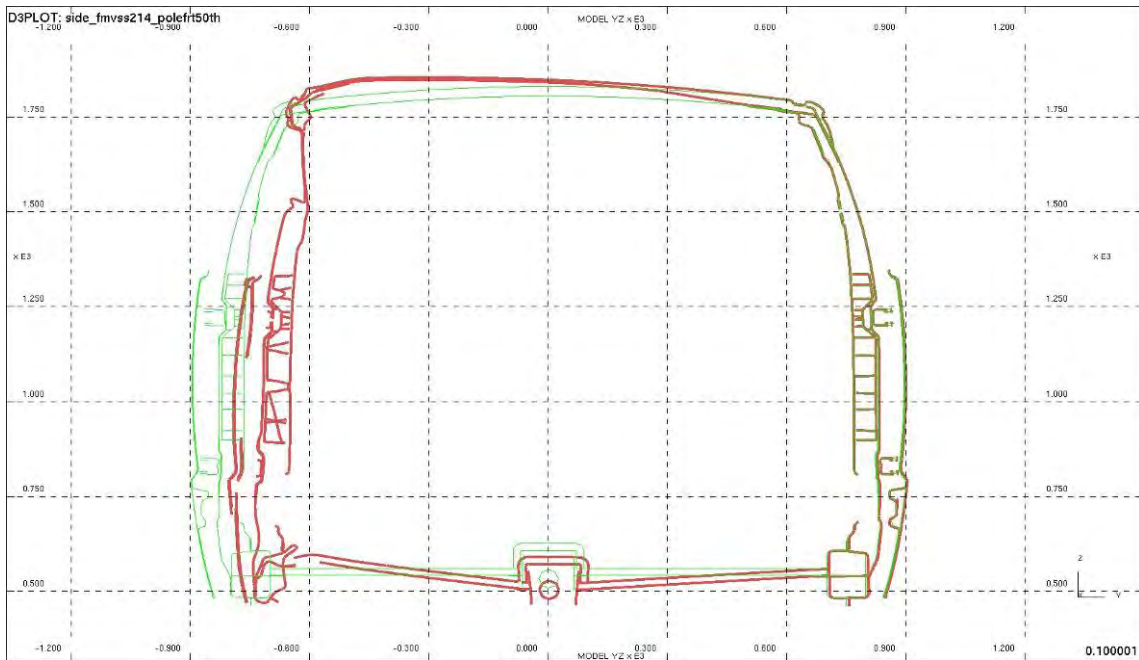

Figure 4.5.4.3.g: Section through B-Pillar, $x = 2842$ after 20-mph, 75-degree side-pole impact -- front (50th percentile male)

Figure 4.5.4.3.h shows the plastic strain for the front door.

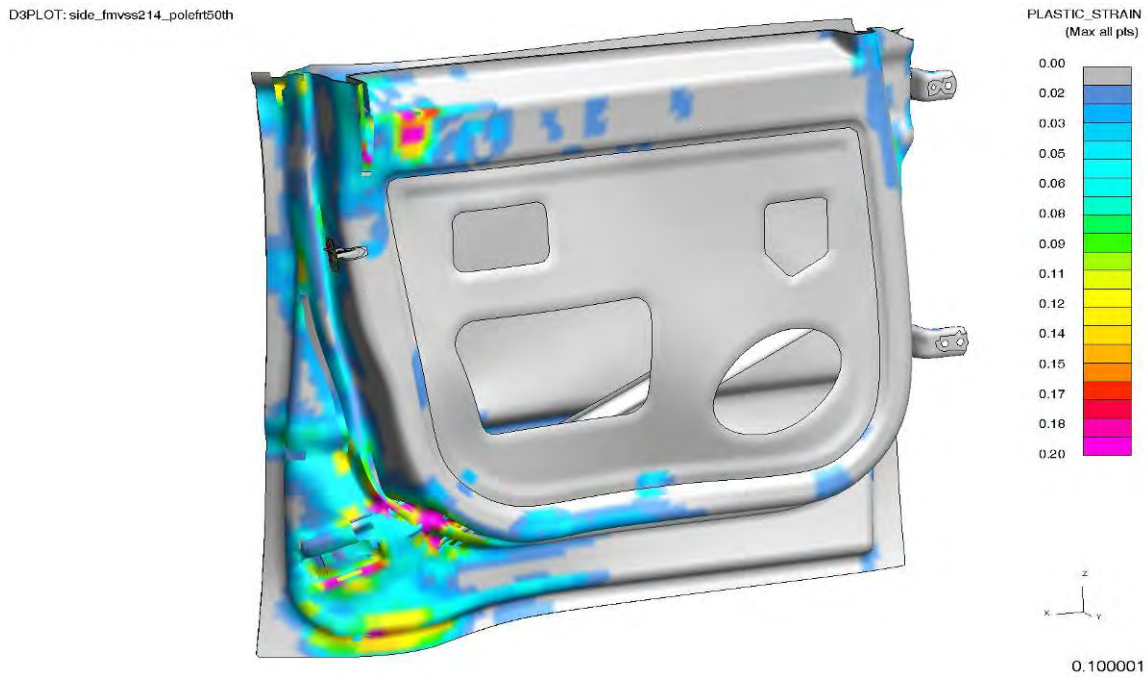

Figure 4.5.4.3.h: Plastic Strain in Front Door after 20-mph, 75-degree side-pole impact -- front (50th percentile male)

Figure 4.5.4.3.i shows the energy balance and that the analysis was valid as no energy was created nor destroyed.

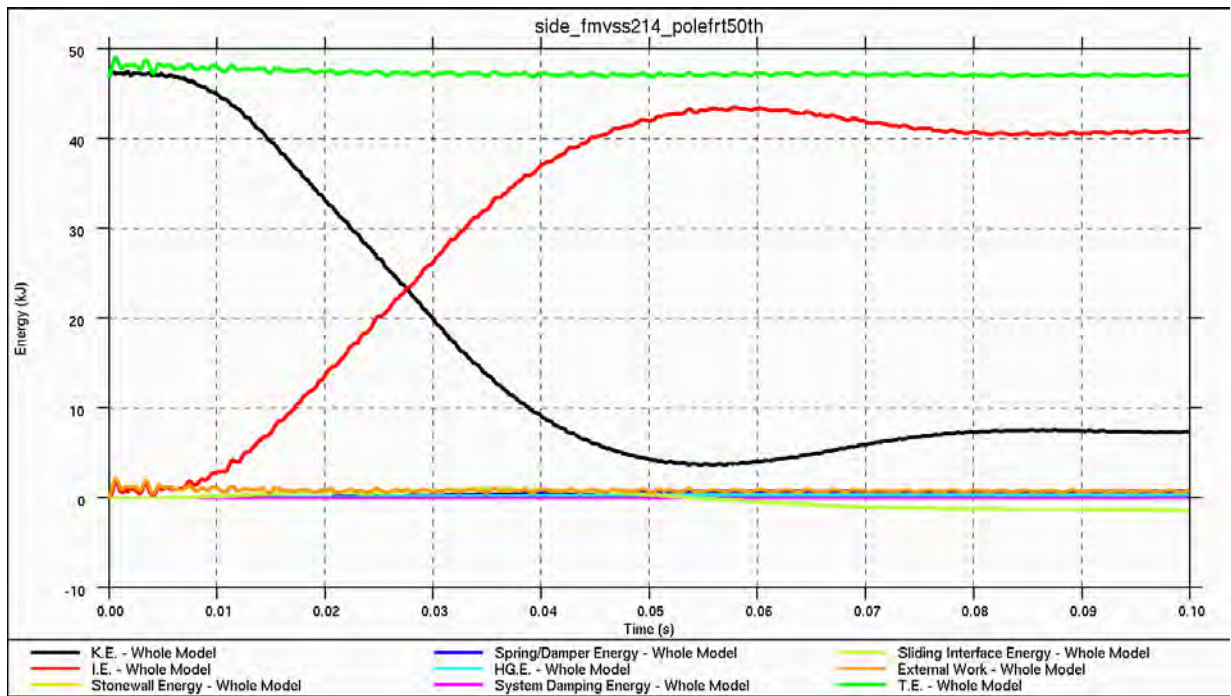

Figure 4.5.4.3.i: Energy Balance for 20-mph, 75-degree side-pole impact -- front (50th percentile male)

4.5.4.3.1. Observations - Side Impact Pole

The side pole impact load cases show that for both the 5th female and the 50th male load cases the intrusion is predicted to be at a maximum at similar door locations. Figure 4.5.4.3.1.a shows a section cut @ 1100z showing the deformation of the 5th load case (in red) vs. the 50th (in green). Intrusion levels at the B-Pillar are different and are a result of the pole location loading directing into the B-Pillar in the 50th location compared to loading into the door on the 5th.



Figure 4.5.4.3.1.a: 5th percentile female vs. 50th percentile male front door intrusion comparison

The cast magnesium door inner material required the inner and outer waist rail reinforcements to be designed to provide extra support. In the 50th male load case there is some tearing of the door inner panel predicted by the analysis that is not predicted in the 5th. This material failure was not previously predicted. The location of the pole in the 50th load case results in more load being reacted at the rear end of the front door. This is a result of the longer moment arm between the pole location and the center of gravity for the forward vehicle mass including the engine and transmission more than offsetting the pole moving closer to the B pillar structure.

In both load cases the rocker is the first substantial load bearing member that the pole contacts which is supported by a number of cross-members. There is more deformation in this area in the 5th load case as the pole deforms the rocker between two cross-members whereas in the 50th case one of the cross-members is directly behind the loaded point in the rocker.

In both load cases the levels of intrusion are predicted to be larger at the door ~50mm than at the B-Pillar. Neither load case is predicting dynamic deformation of the interior body structure above 250mm.

4.5.4.4. Roof Crush

The FMVSS216a roof crush load case evaluates vehicle performance in a ‘roll-over’ crash scenario. The actual test is carried out quasi-statically to represent a load being applied to the upper A-pillar joint. The regulation specifies that the vehicle should be able to withstand 3 times its curb weight without loading the head of a Hybrid III 50th percentile male occupant with more than 222N (50lbs). This analysis includes testing for the 95th and 99th percentile male occupants.

The previous version (#26) of the CAE model predicted performance levels that were acceptable. The reasons for performing this analysis on the latest version of the model (#27) were due to the changes that were made to the A-Pillar/Front Header & Cowl to improve the stiffness performance. Figure 4.5.4.4.a shows the model setup.

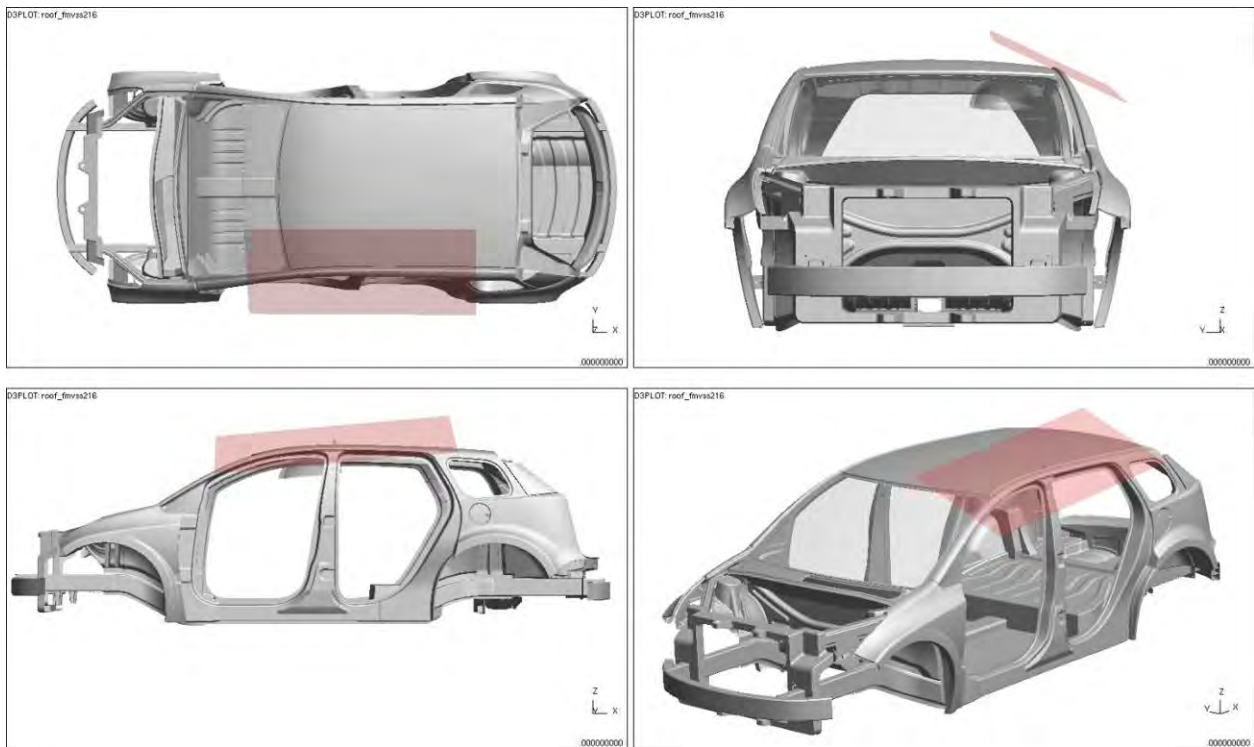

Figure 4.5.4.4.a: Roof crush model setup

Figure 4.5.4.4.b shows the roof deformation for a series of increasing platen displacements.

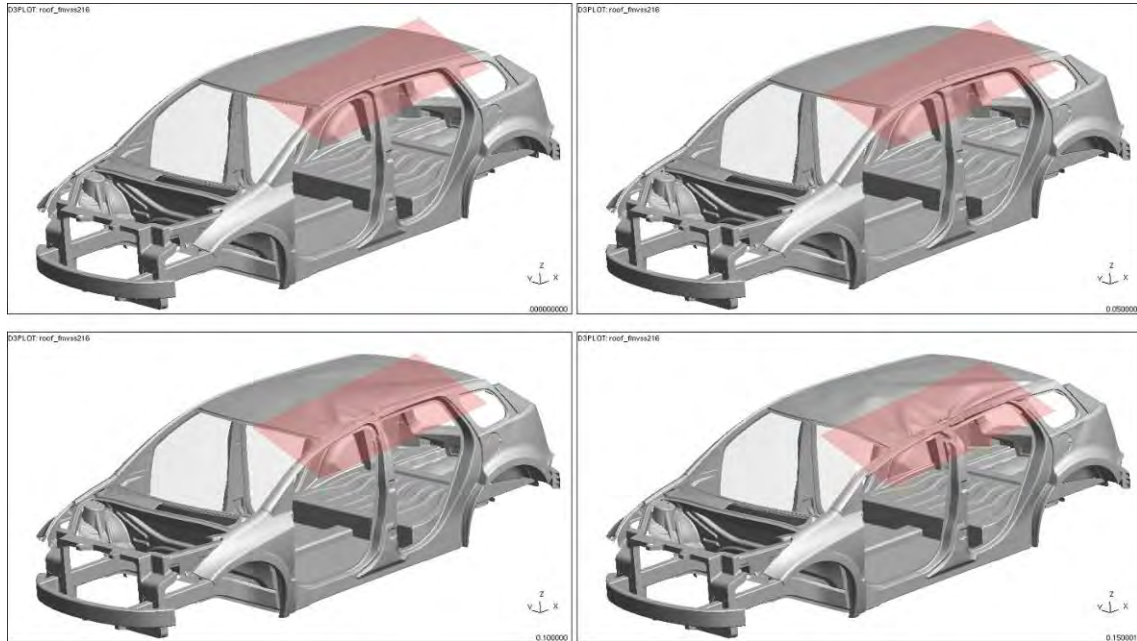
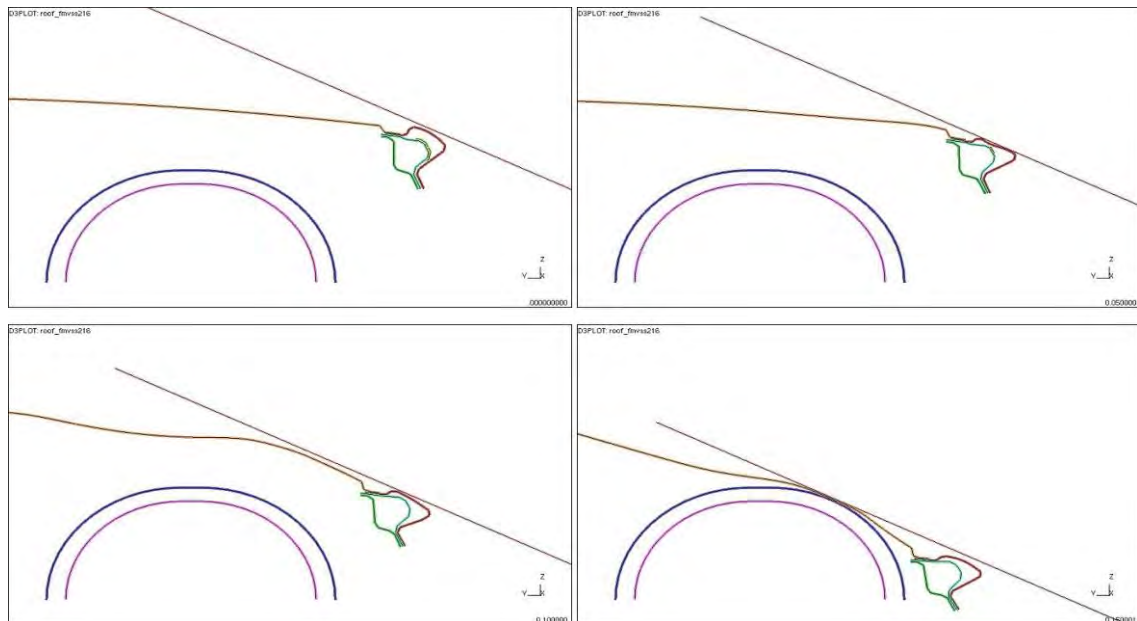

Figure 4.5.4.4.b: Deformation at 0/40/80/150mm of Platen Displacement

Figure 4.5.4.4.c shows the roof deformation relative to 95th and 99th percentile head clearance zones.



**Figure 4.5.4.4.c: Deformation in Relation to occupant head clearance zones (95th/99th)
@ 0/40/80/150mm of Platen Displacement**

Figures 4.5.4.4.d and 4.5.4.4.e show the roof deformation relative to the FMVSS 216 requirement.

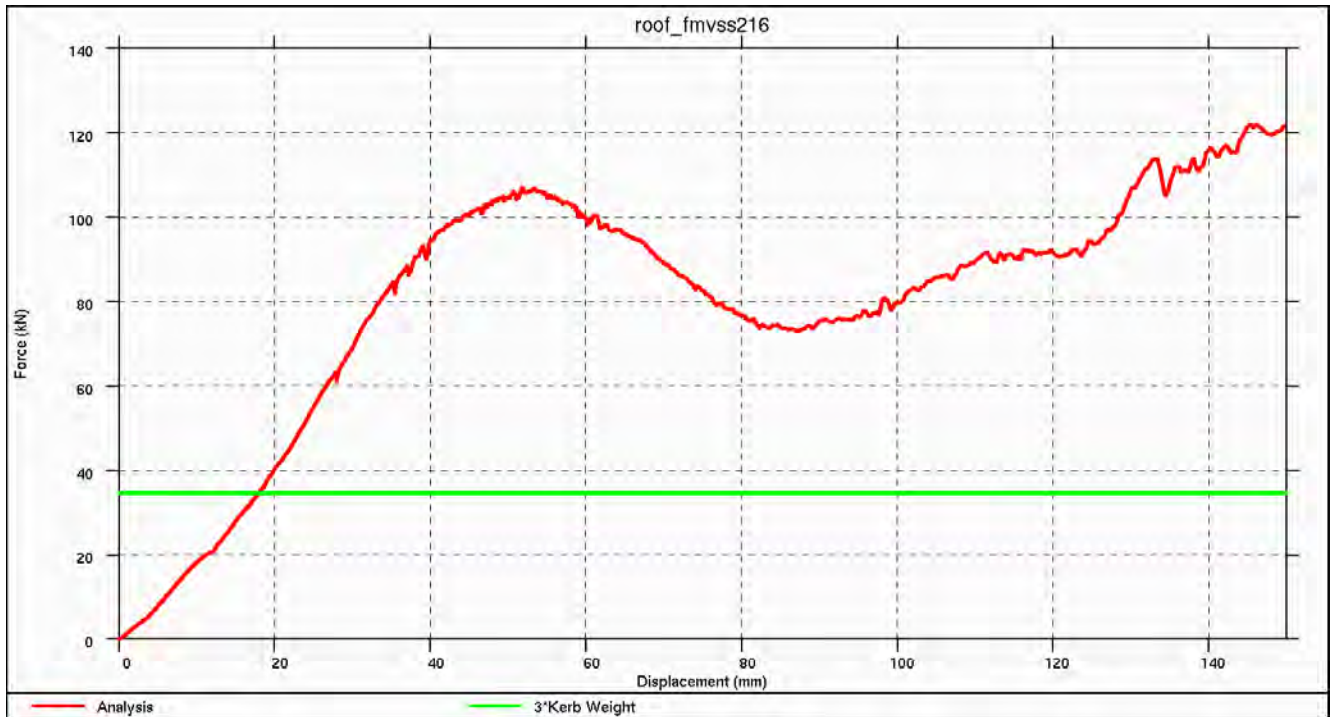

Figure 4.5.4.4.d: Roof Displacement vs. Applied Force – 3 times Curb Weight

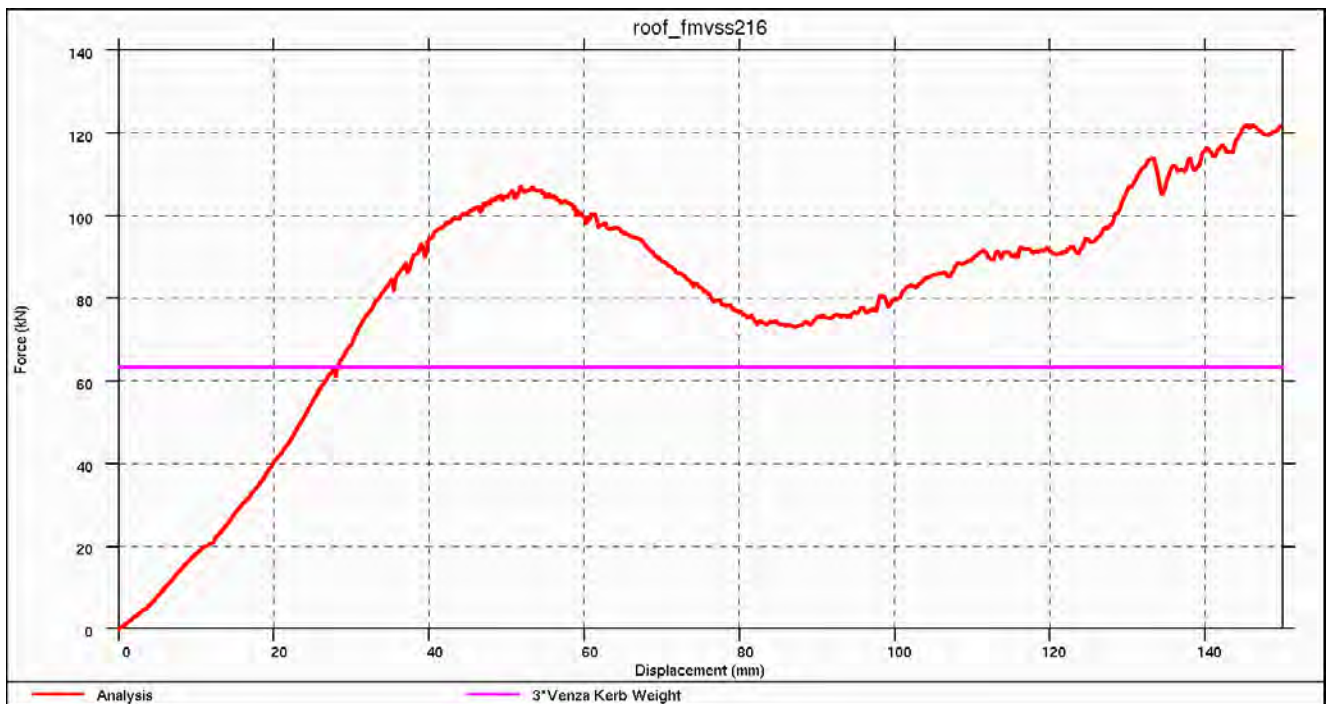

Figure 4.5.4.4.e: Roof Displacement vs. Applied Force – 3 times Venza Weight

Figure 4.5.4.4.f shows the roof plastic strain relative to platen displacement.

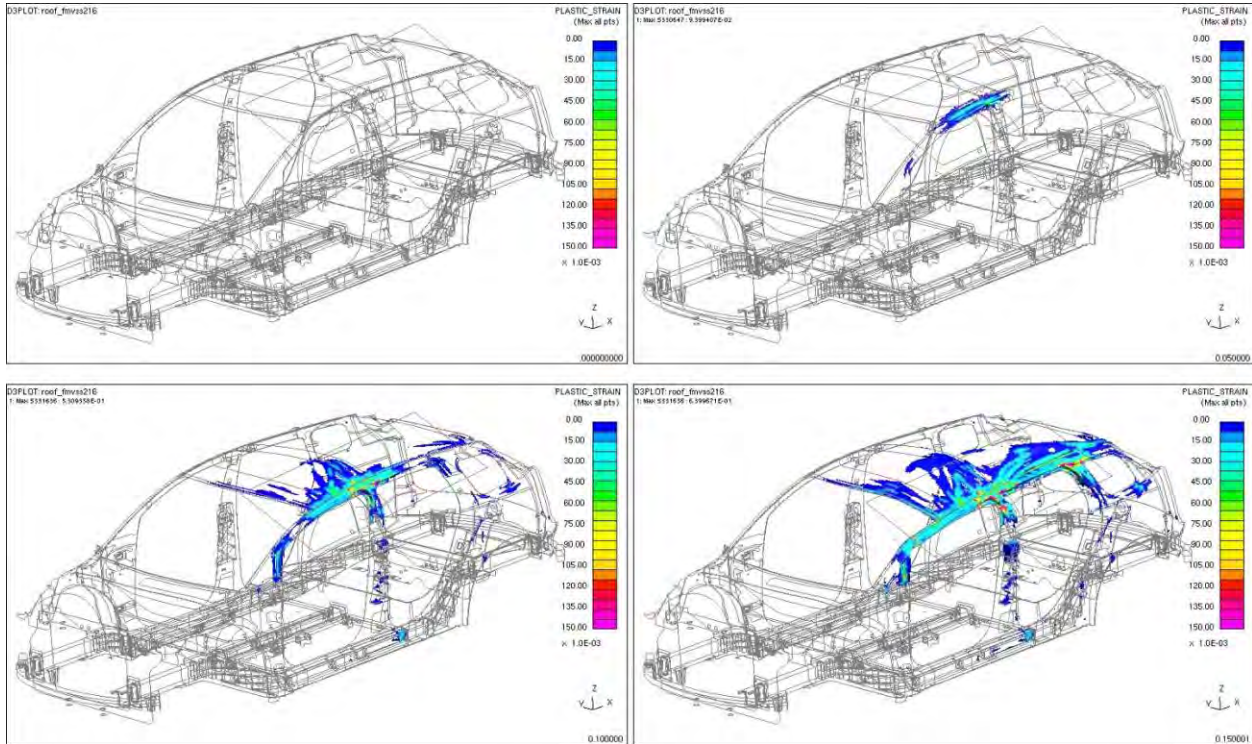

Figure 4.5.4.4.f: Plastic Strains @ 0/40/80/150mm of Roof Platen Displacement

4.5.4.4.1. Observations - Roof Crush

The current model is predicting results that are very similar to the previous version of the model (V26). The analysis predicts that the 3*vehicle weight requirement (FMVSS216a) is achieved within the first 20mm of platen displacement performance and that 4*vehicle weight requirement (IIHS – Good Rating) will be achieved within 25mm of platen displacement.

The styling of the upper greenhouse of the vehicle and the rake of the windshield direct the platen loads through the B-Pillar. This load is reacted in compression which provides a substantially higher load carrying capacity than at the base of the A-Pillar, which is put into bending. The figure below shows the location and magnitude of forces in the A & B-Pillars. Figure 4.5.4.4.1.a shows the relative forces acting on the A and B pillars.

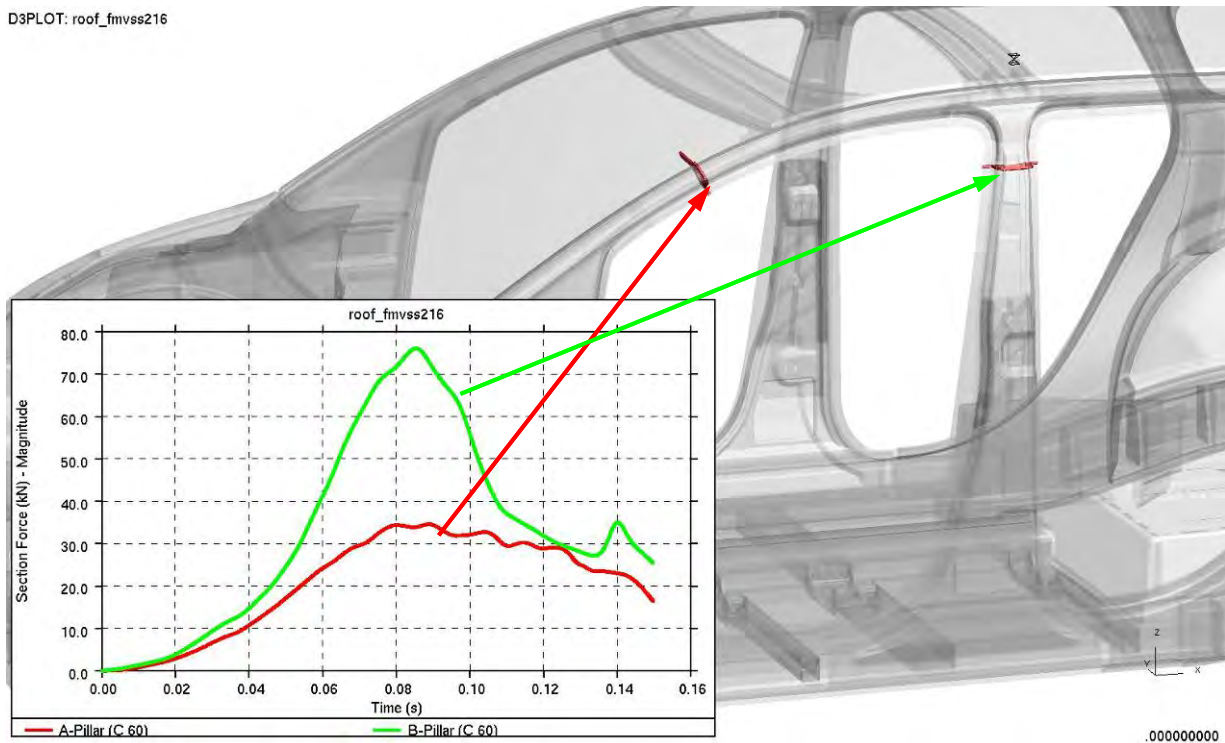

Figure 4.5.4.4.1.a: Resultant force magnitude in A & B-Pillars from roof crush test

4.5.4.5. Rear Impact

The FMVSS301 50mph 70-percent overlap rear moving deformable barrier load case primary function is to ensure the vehicle fuel system integrity is maintained to reduce potential vehicle fires caused by fuel spillage, during and after impact. The previous model did not indicate that there would be any issues with the integrity of the fuel tank/filler; the model was re-evaluated under this load case as there had been a change to the rear bumper system.

Assessment was carried out by looking at the deformation of the body structure around the fuel tank as well as the fuel tank and the fuel tank/filler. Figure 4.5.4.5.a shows the model setup.

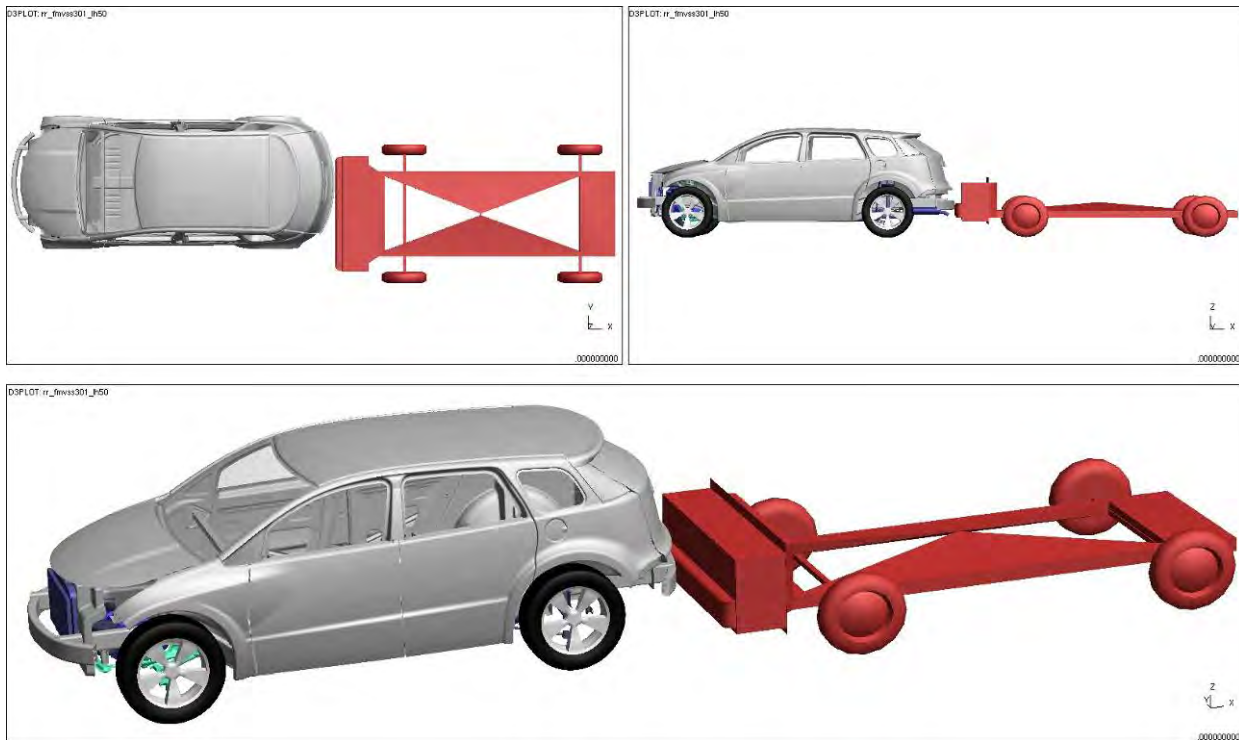

Figure 4.5.4.5.a: Rear Impact Model Set up

Figures 4.5.4.5.b and 4.5.4.5.c show the vehicle deformation.

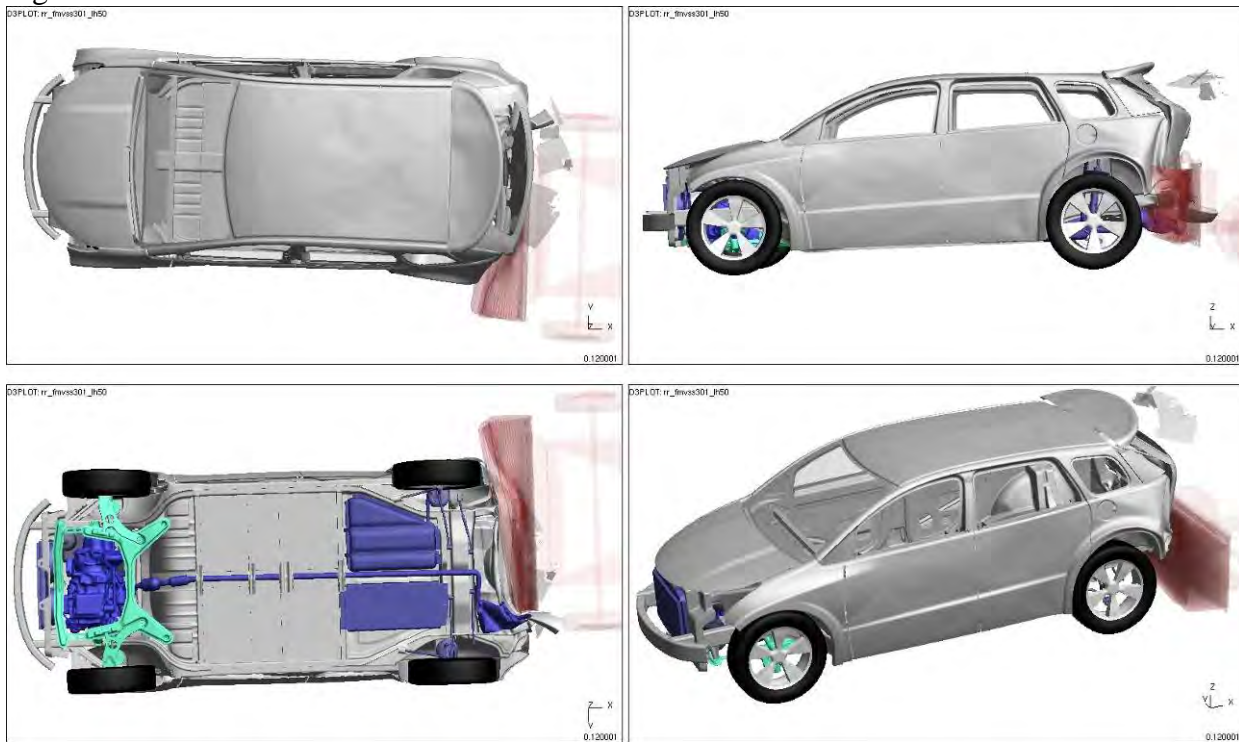

Figure 4.5.4.5.b: Vehicle Deformation ($t=0.12s$)

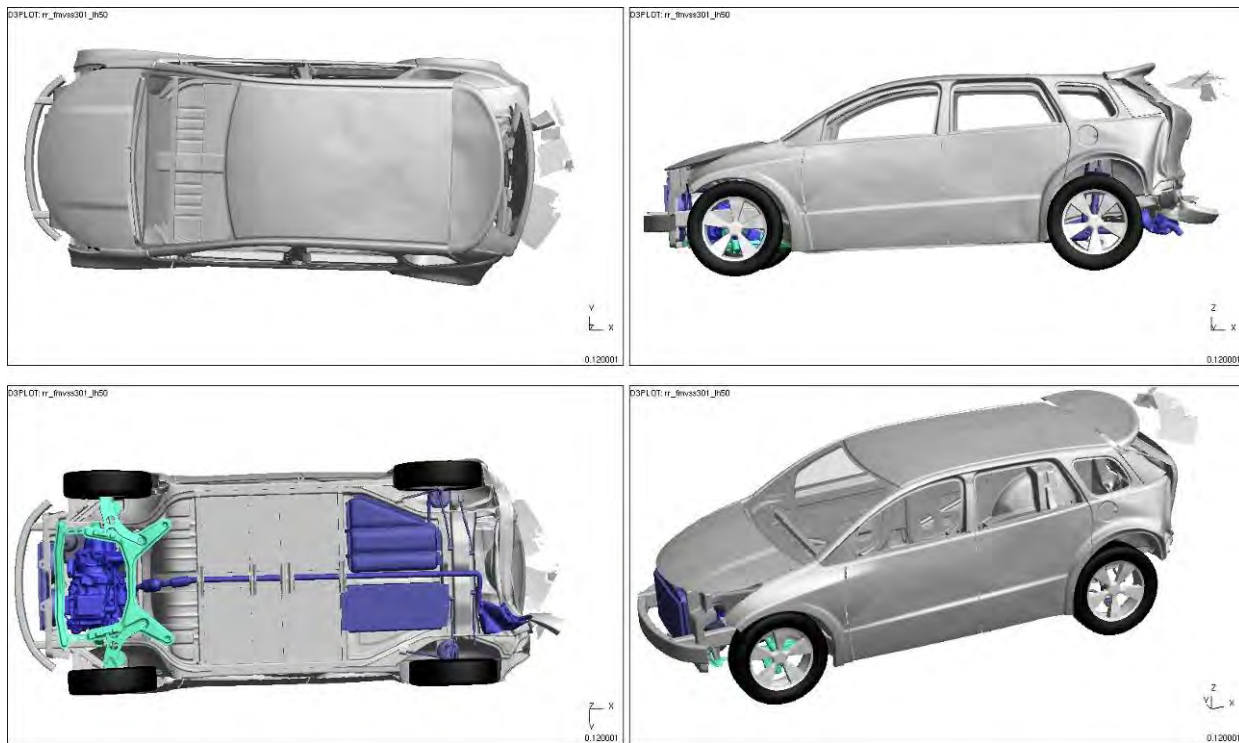

Figure 4.5.4.5.c: Vehicle Deformation (Barrier Blanked)

Figure 4.5.4.5.d shows the vehicle deformation as a function of the event timing.

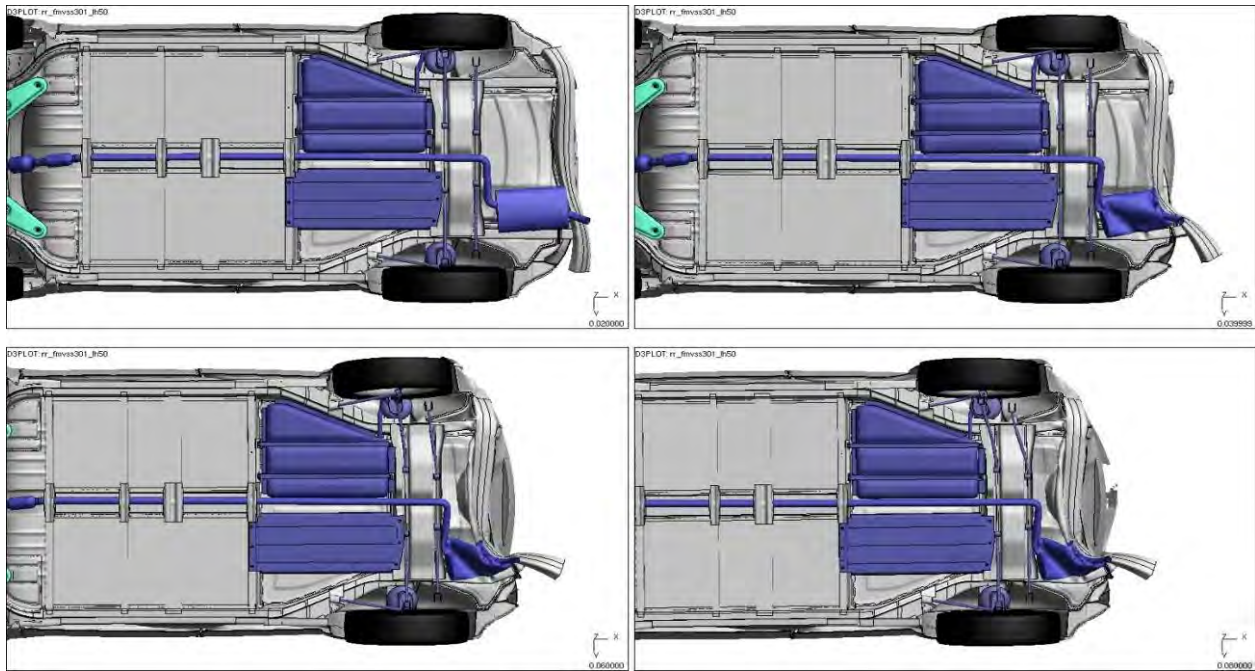

Figure 4.5.4.5.d: Vehicle Deformation (@ 0ms/40ms/80ms/120ms) after rear impact

Figure 4.5.4.5.e shows the B pillar acceleration levels as a function of the event timing.

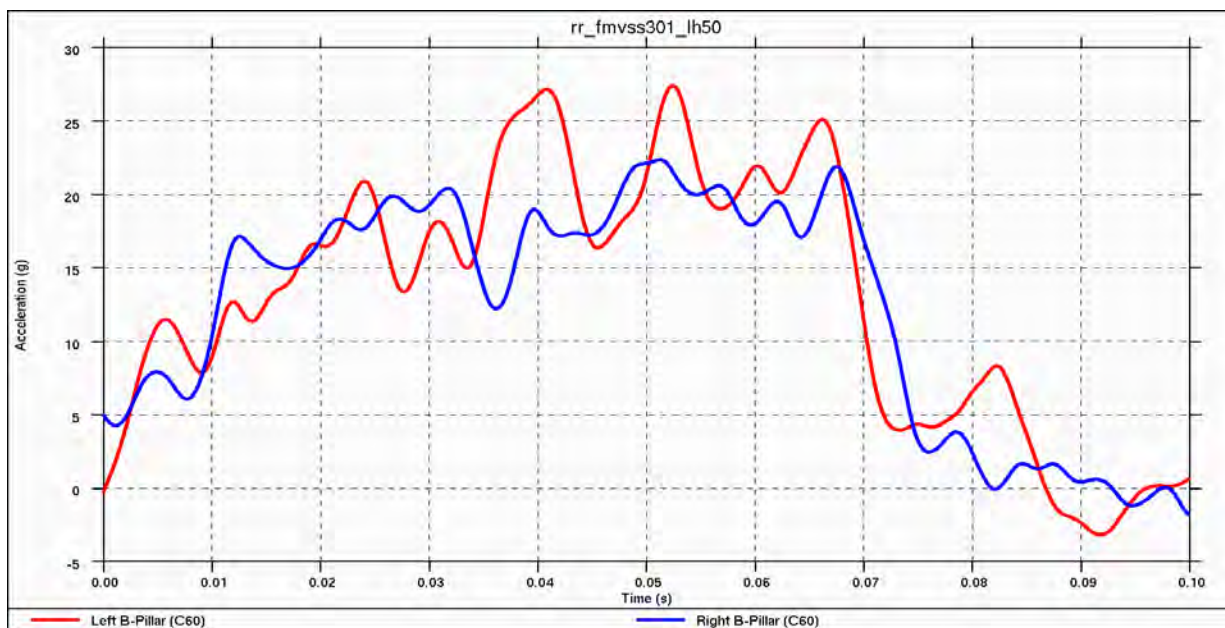

Figure 4.5.4.5.e: Vehicle Acceleration Pulse during rear impact

Figure 4.5.4.5.f shows the vehicle & barrier velocities.

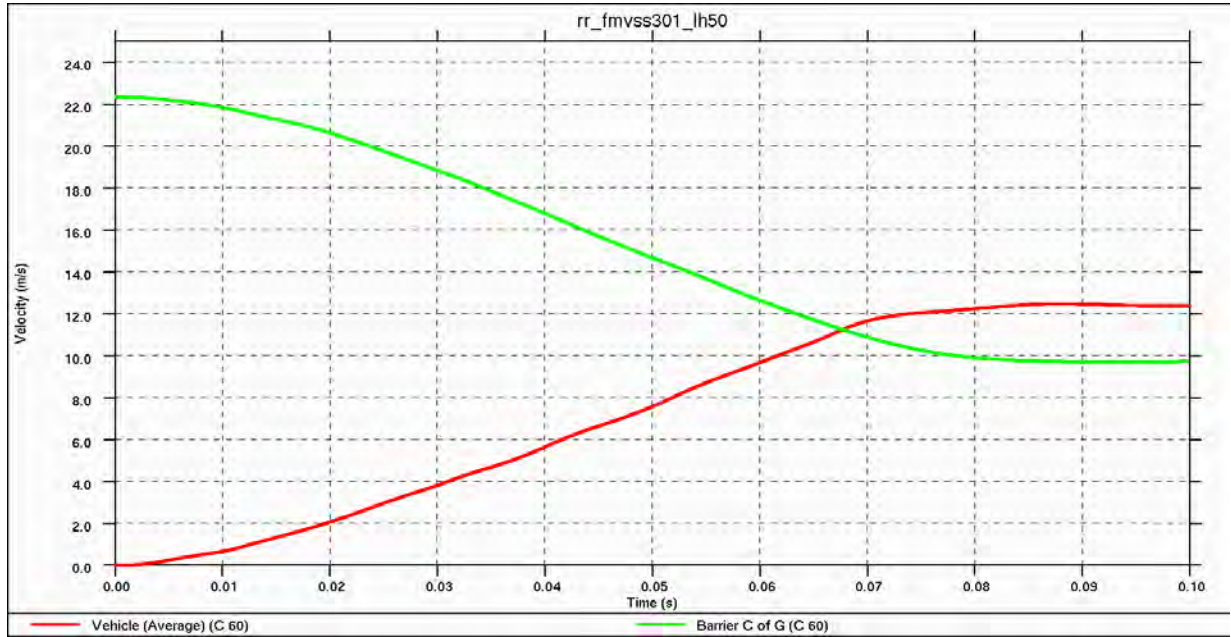

Figure 4.5.4.5.f: Vehicle & Barrier Velocities during rear impact simulation

Figure 4.5.4.5.g shows the fuel tank plastic strain.

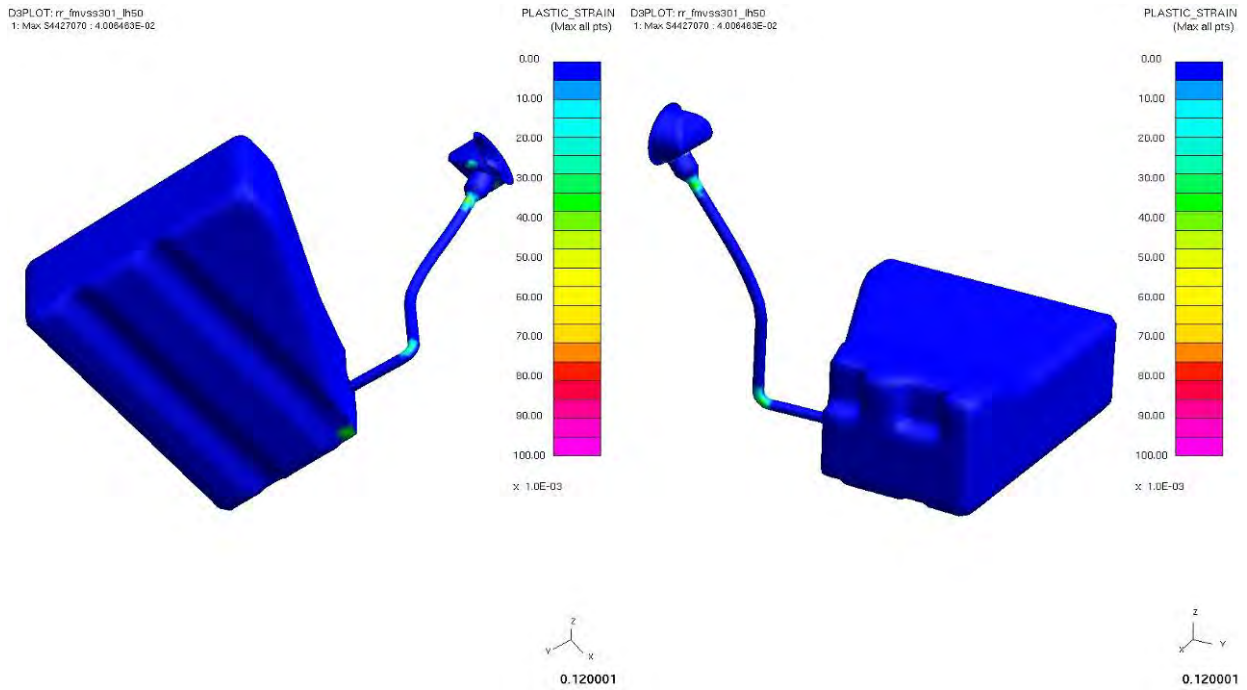

Figure 4.5.4.5.g: Fuel Tank Plastic Strains after rear impact

Figure 4.5.4.5.h shows the energy balance verifying that the overall energy is held constant.

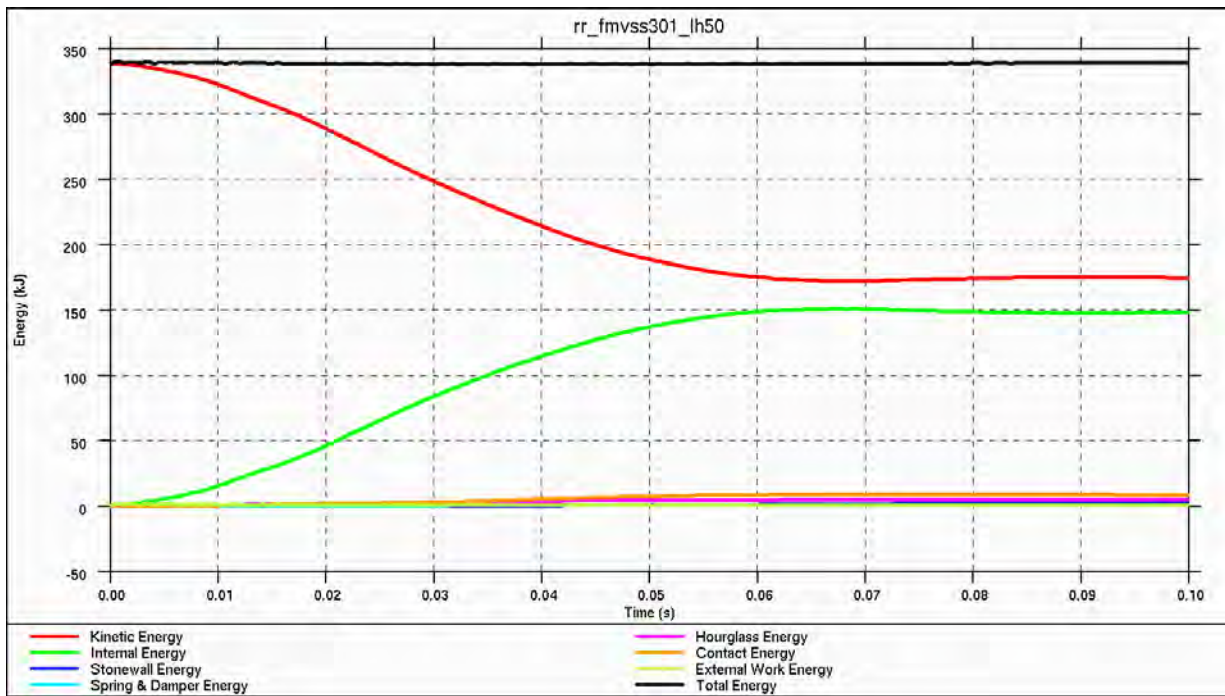

Figure 4.5.4.5.h: Rear impact energy balance

4.5.4.5.1. Observations - Rear Impact

The barrier to vehicle cross-over velocity occurs 2ms earlier than previously predicated at ~67ms; and the vehicle acceleration response also shows a slight increase in the peak accelerations reported for the struck side of the vehicle.

The reduced time to cross-over velocity and increase in the acceleration response is expected as there is less compliance in the vehicle; excluding the tailgate results in less stiffness of the rear aperture, and including the ‘full’ doors with result in less flexing of the door apertures.

There is an area on the fuel tank where there is plastic strain and this is more a modeling induced strain rather than a real factor, as there are four rigid connections used between the fuel tank straps and the fuel tank to hold it in place. Rigid elements concentrate the load transfer between the connected parts to discrete nodes which is somewhat unrealistic in the case of the tank straps as these would spread the load over a larger area. Plastic strain in the fuel tank is predicted to be 3.6-percent maximum, which is less than the failure strain for the typical plastic fuel tank material properties (generic plastic properties used in the CAE model with a yield stress of 25MPa). This is shown in Figure 4.5.4.5.1 a.

D3PLOT: rr_fmvs301_1h50

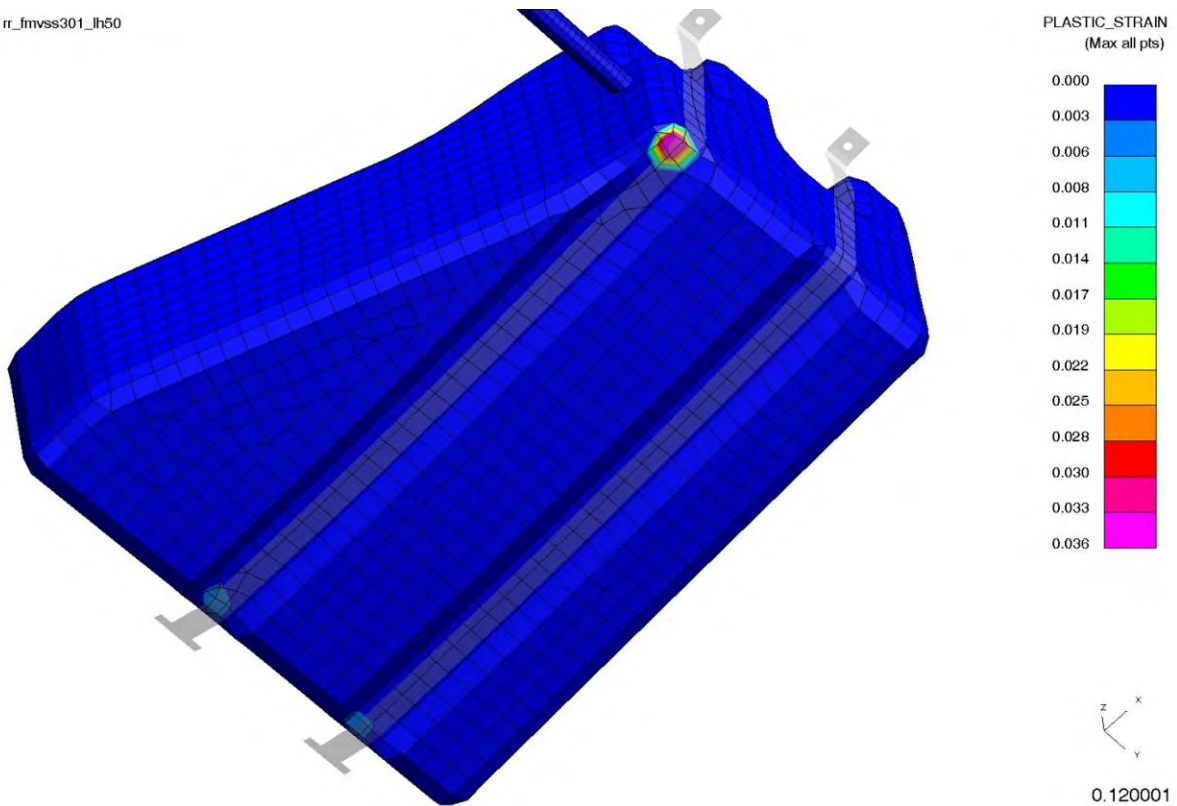

Figure 4.5.4.5.1.a: Fuel Tank Plastic Strain location after rear impact

The airbag that was included to monitor the pressure change in the fuel tank indicates a change of less than 0.3psi (<2 percent); this is the same as predicted for the previous run.

As a result of moving the rear bumper armature rearwards the length of the crush can has increased. This increase in length increases the moment arm (measured from the rearward face of the bumper armature to the mounting surface). While this does not noticeably change the mode of deformation, it does make it harder to resist the rotation of the bumper armature. This rotation is shown in Figure 4.5.4.5.1.b.

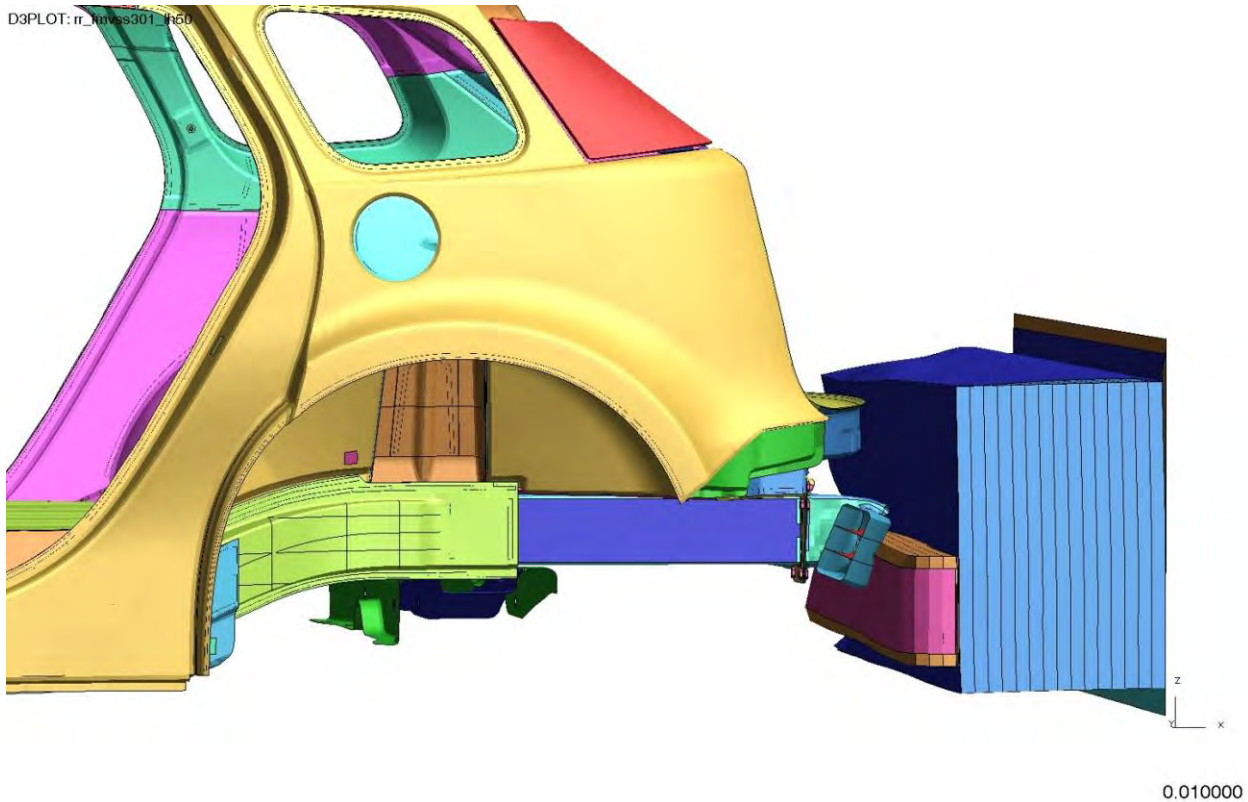

Figure 4.5.4.5.1.b: Initial vehicle armature rotation during rear impact

It will be difficult to get to the ideal failure mode (axial crush) using extrusions. The ideal loading would ensure 100-percent engagement of the vehicle armature with the barrier. The height locations of vehicle armatures are typically set based upon the requirements for FMVSS Part 581 pendulum. Extending the rail and bumper armature to get full engagement is not required as the analysis predict that the vehicle deformation occurs behind the rear wheels.

4.5.4.6. IIHS Low Speed – Rear

The previous V26 model IIHS rear low speed analysis indicated that in both the 10kph ‘full’ overlap and 5kph 15-percent overlap load cases there could be potential for damage to occur to the body. It was not possible to state that this would be eliminated 100 percent with the inclusion of bumper foam (which is typically used, but not included in the CAE model).

With the inclusion of the rear tailgate in the V27 model the rear lower edge was the rearward most point in the vehicle. This indicates that for these IIHS load cases there would be damage to the non-bumper system components.

The latest version of the CAE model (#27) include a modified bumper beam assembly, where the curvature of the bumper follows the curvature of the tailgate lower edge and is also the rearward most point in the vehicle. The model does not include the fascia or foam which would add an additional 40-50mm.

The CAE performance assessment is based on the extent of any permanent deformation and plastic strain that is predicted in the structure. Figure 4.5.4.6.a shows the model setup.

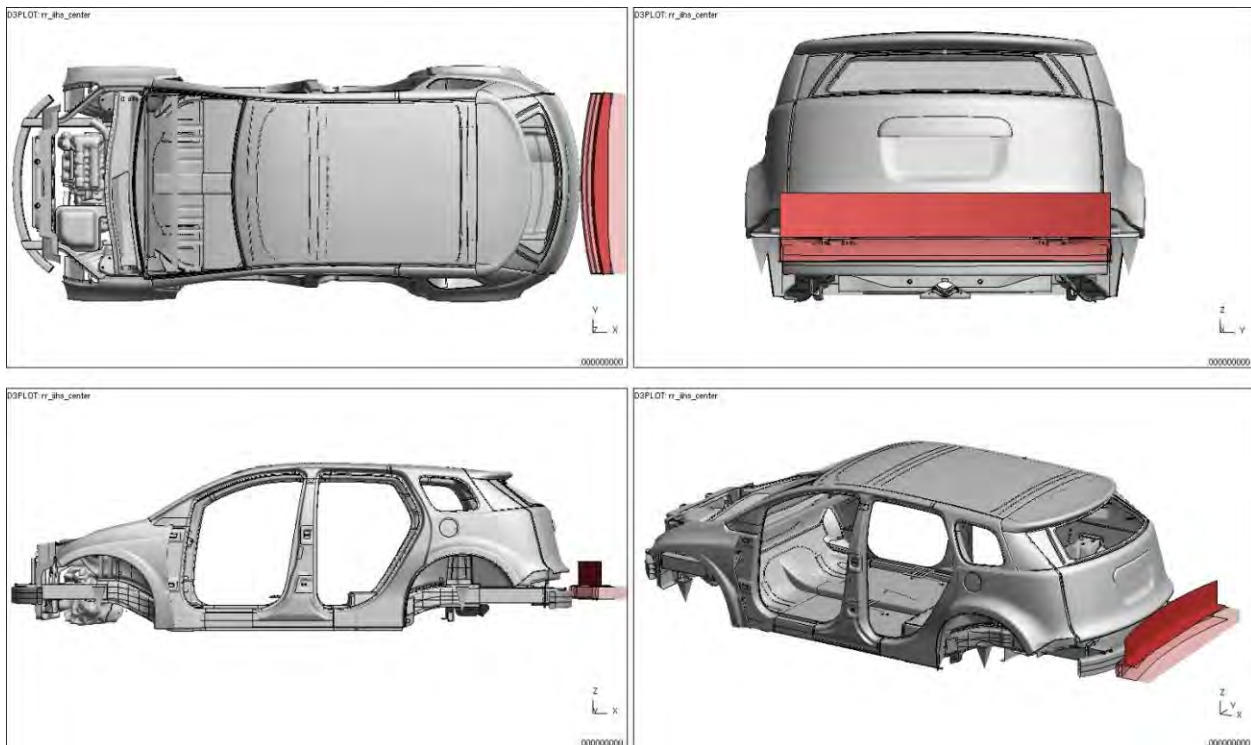

Figure 4.5.4.6.a: Low-speed IIHS impact model setup ('full')

Figure 4.5.4.6.b shows the plastic strain for the impact beam for a center impact.

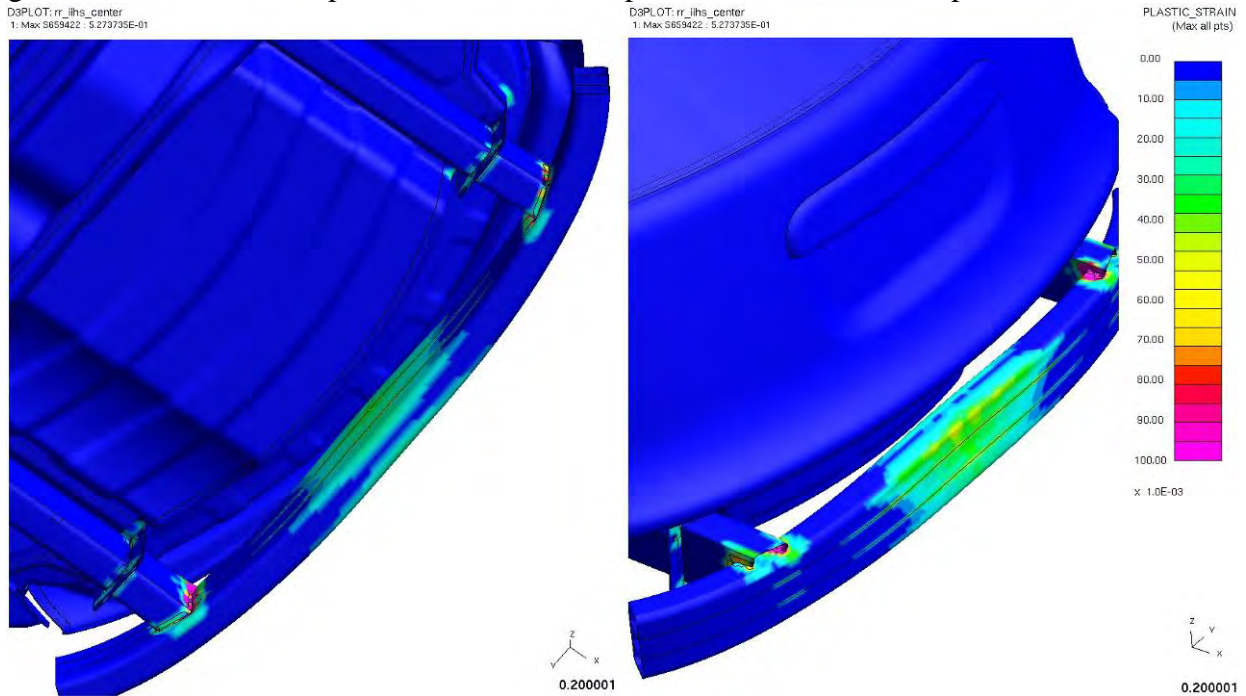

Figure 4.5.4.6.b: IIHS low-speed impact element plastic strains ('full')

Figure 4.5.4.6.c shows the model setup for an offset impact.

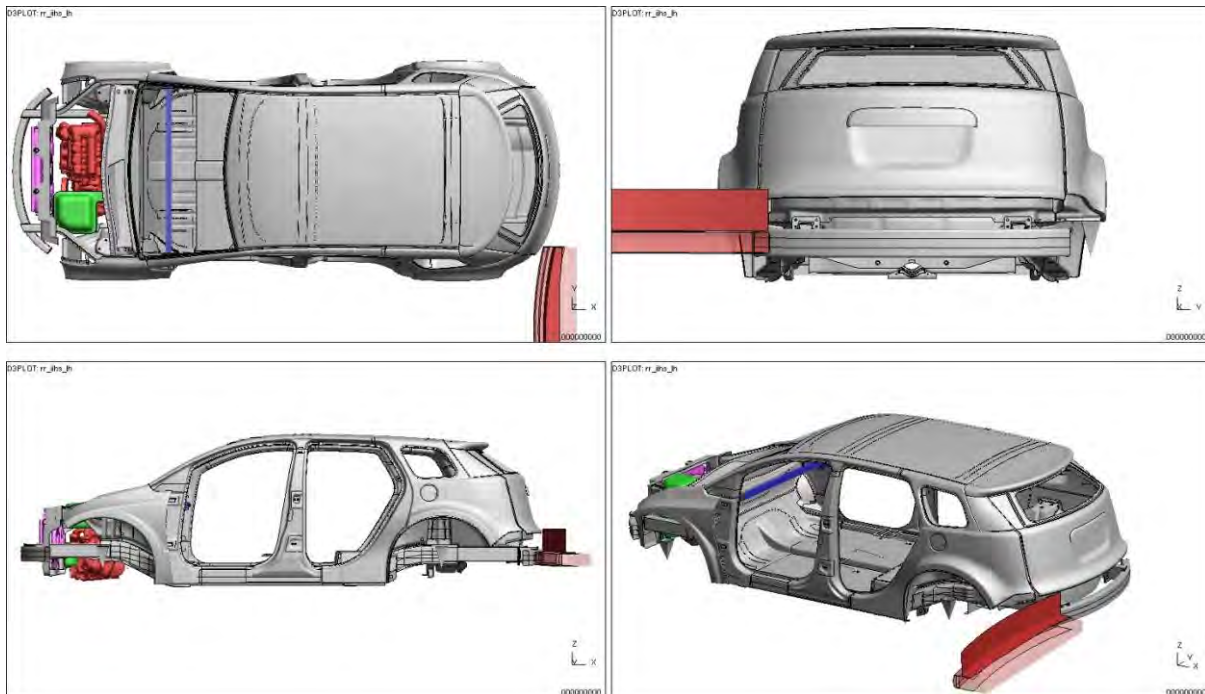

Figure 4.5.4.6.c: IIHS low-speed impact model setup ('offset')

Figure 4.5.4.6.d shows the plastic strain for the impact beam for an offset impact.

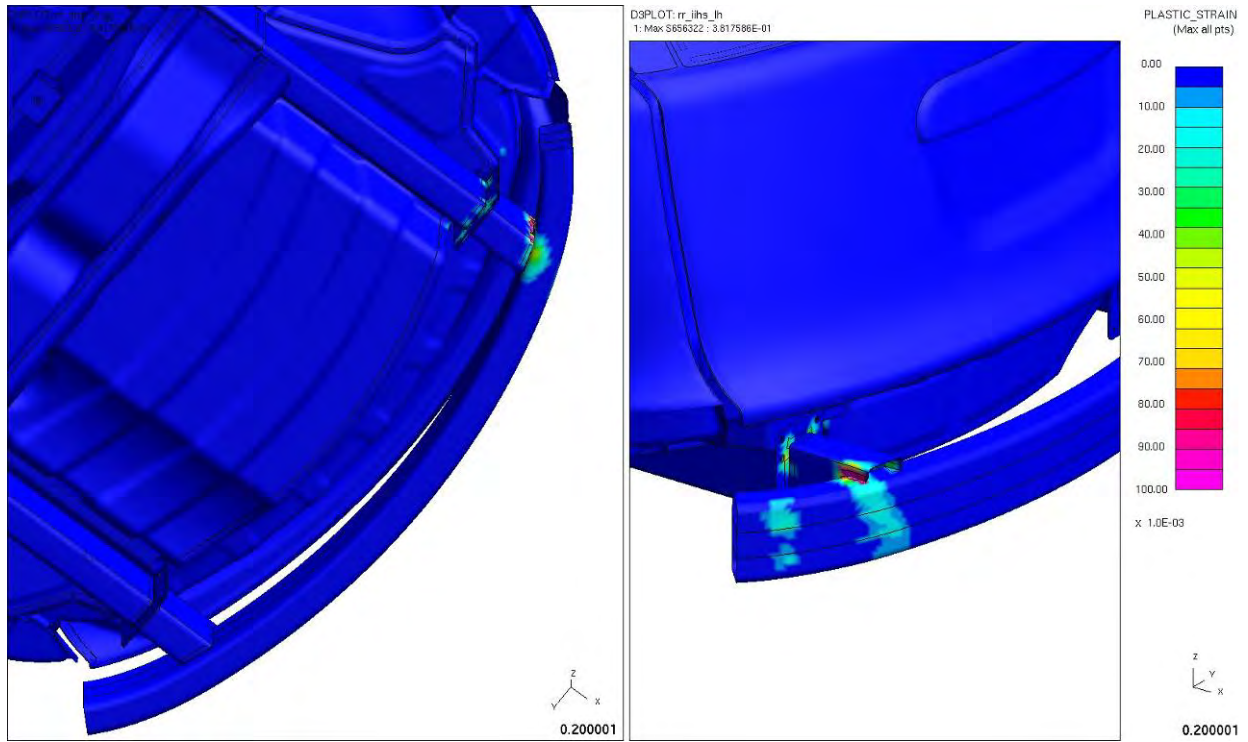

Figure 4.5.4.6.d: IHS low-speed impact element plastic strain ('offset')

4.5.4.6.1. Observations - IIHS Low Speed – Rear

In the ‘full’ overlap load case the center of the bumper armature is predicted to deform a maximum of ~85mm during impact and have ~66mm of permanent deformation once the impact event is over. With the change to the shape and location of the rear bumper armature there is ~125mm of available space (measured on vehicle centerline) before there would be contact.

The barrier upper ‘rigid’ plane does ‘intrude’ into the bottom edge of the tailgate by ~27mm (see figure below). Contact was not defined between these parts as the maximum interaction would be measured during post-processing. Typically bumper systems are comprised of an armature, EA foam and a plastic fascia. The ARB model does not include these additional items as they are part of a styled bumper system which was beyond the project scope. This hardware would (i) spread the load over a wider area of the armature and (ii) impart load onto the bumper armature earlier therefore slowing the vehicle down sooner. Typical EA foam thickness on vehicle centerline would be ~75mm. Under this impact case the EA foam would compress to approximately 60% of its original thickness (~45mm); therefore if the model did include a full bumper system there would be no direct contact between any bodywork and the barrier and no damage to the body. Figure 4.5.4.6.1.a illustrates the maximum deflection showing barrier intrusion into tailgate.

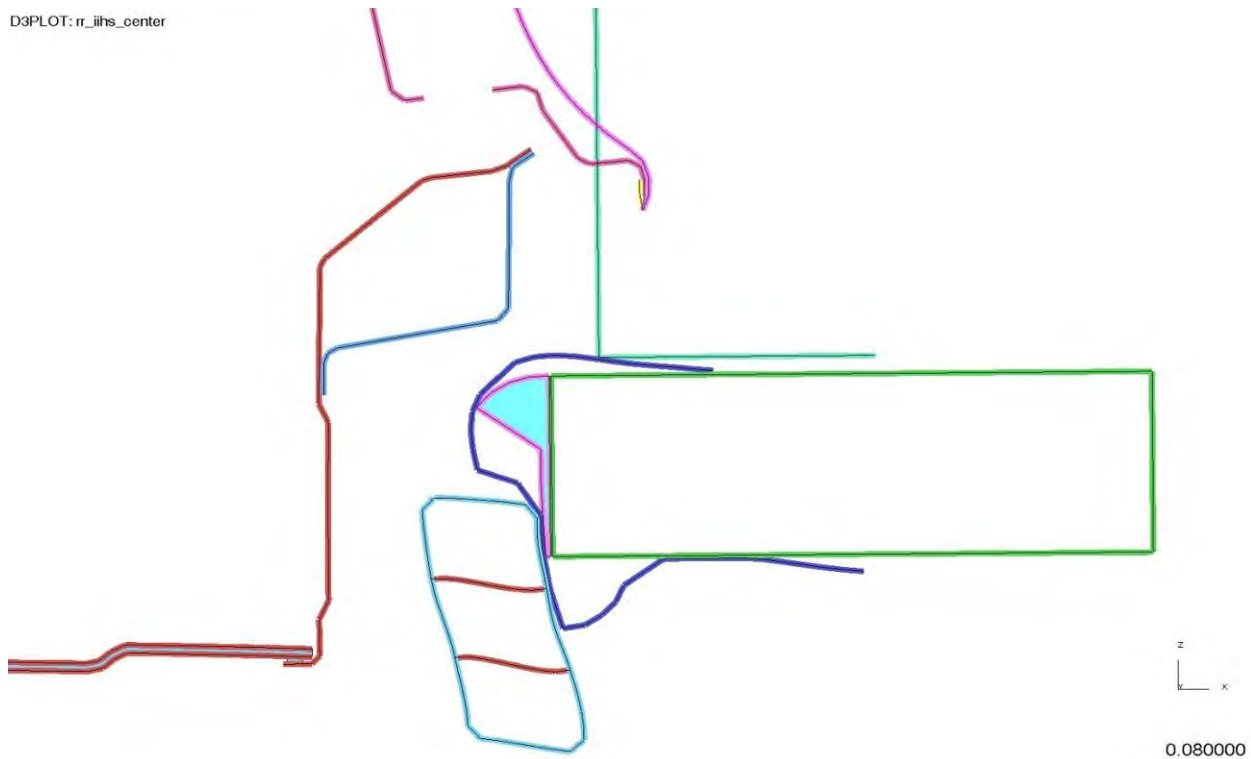

Figure 4.5.4.6.1.a: Maximum deflection showing barrier intrusion into tailgate

Plastic strain under this loading is contained within the bumper system with the maximum strain occurring in the heat affected zone (the welded area between the armature and crush can).

In the 'offset' impact load case, the analysis predicts that there will be no contact between the barrier and the vehicle bodywork. The maximum dynamic deflection at the end of the armature is predicted to be ~86mm and there is sufficient clearance to the body such that there should be no contact. Deflection at the end of the analysis (200ms) is predicted to be ~72ms. Unlike the 100-percent overlap case the analysis predicts lateral movement of ~37mm in the vehicle during the impact as it 'slides' along the face of the barrier. During this sliding the barrier remains in contact with the bumper armature (still 50mm of engagement) until the vehicle starts to rebound. See Figure 4.5.4.6.1.b below.

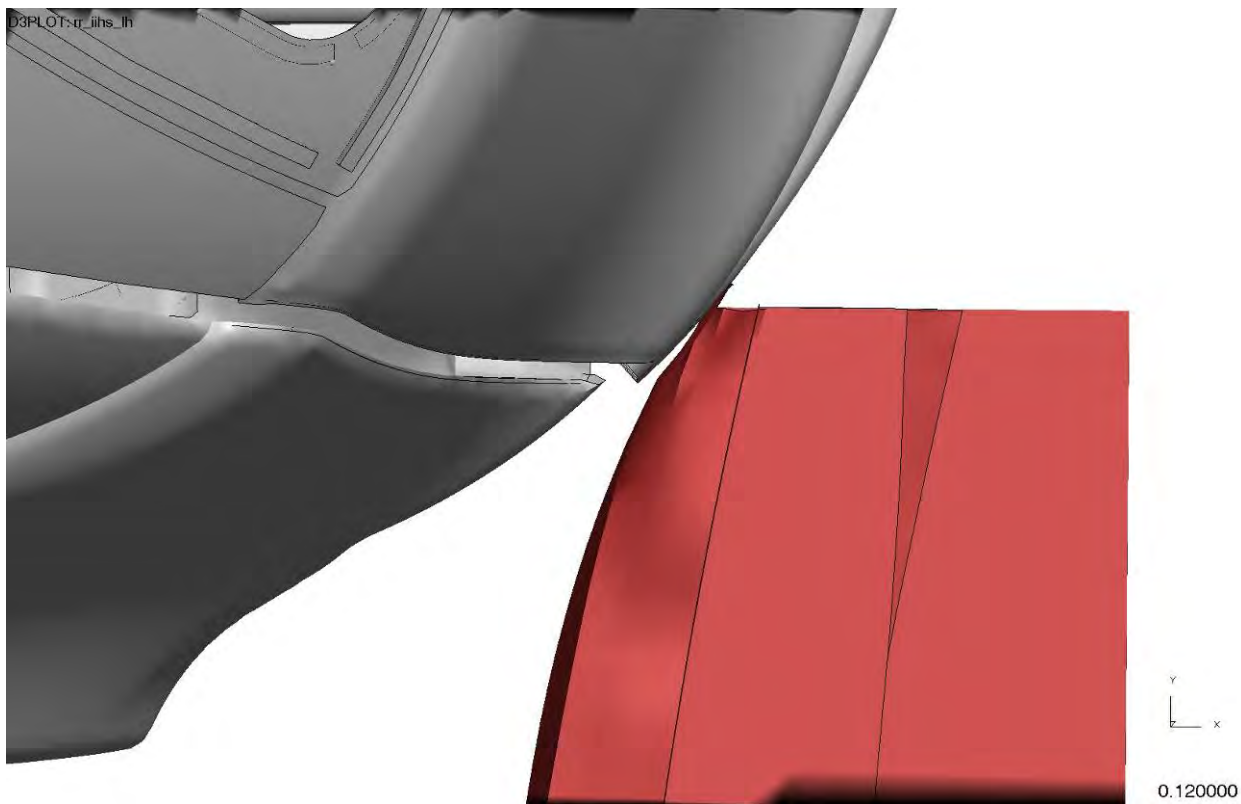

Figure 4.5.4.6.1.b: 'Deformation' @ maximum deflection

As with the 100-percent overlap load case the plastic strain is contained within the bumper system. As the barrier loads an unrestrained end of the armature, the plastic strains are confined to the armature and the crush can welded area on the struck side.

4.5.5. Bill of Materials.

The body structure Bill of Materials (BOM) is shown below in Table 4.5.5.a. The mass is 241.8 kg, which is 37-percent lower than the baseline Toyota Venza body structure. The total parts count of the Phase 2 HD body is 169, compared to 211 for the Phase 1 HD body and 269 parts for the baseline Venza body. The direct manufacturing cost of this Phase 2 HD BIW design is approximately \$432. Note that the front end module is not part of the BIW structure as it is a bolt on part. It is included in the parts count, mass and cost to provide parity with the baseline Venza BIW which includes this structure. The BIW mass less the 7.66 kg for these front end parts is 234.1 kg.

Table 4.5.5.a: *Bill of Materials*

| Part Number | Part Name | Material | Thickness (mm) | BIW Mass (kg) |
|---|--|----------------------|----------------|---------------|
| Complete body - less bumpers and fenders | | | | 241.8 |
| Front End | | | | |
| 7305-2400-209 | Front end module | Magnesium - AM60 | 4.50 | 5.85 |
| 7305-2400-001 | Small crossmember reinforcement | Aluminum - 6022-T4 | 4.00 | 1.23 |
| 7305-2400-002 | Large crossmember reinforcement | Aluminum - 6022-T4 | 4.00 | 0.57 |
| Sub-total | | | | 7.66 |
| Floor | | | | |
| 7306-2400-229 | Floor panels (left and right) | Composite | | 7.77 |
| 7306-2400-231 | Center floor panel | Composite | | 1.81 |
| 7307-2400-115 | Rear passenger compartment floor panel | Composite | | 3.27 |
| Sub-total | | | | 12.85 |
| Left-side Bodyside Outer Assembly | | | | |
| 7306-2300-185 | Rear panel | Aluminum - 6022 - T4 | 1.20 | 5.15 |
| 7306-2300-183 | Front panel | Aluminum - 6022 - T4 | 1.20 | |
| 7306-2300-187 | Lower, rear, quarter panel closeout | Aluminum - 6022 - T4 | 2.50 | 0.41 |
| 7306-2300-189 | Flange to body panel | Aluminum - 6022 - T4 | 2.50 | 0.46 |
| 7306-2300-191 | Tail lamp close out panel | Aluminum - 6022 - T4 | | 0.09 |
| Sub-total | | | | 6.11 |
| Right-side Bodyside Outer Assembly | | | | |
| 7306-2300-186 | Rear panel | Aluminum - 6022 - T4 | 1.20 | 5.16 |
| 7306-2300-184 | Front panel | Aluminum - 6022 - T4 | 1.20 | |
| 7306-2300-188 | Lower, rear, quarter panel closeout | Aluminum - 6022 - T4 | 2.50 | 0.41 |
| 7306-2300-190 | Flange to body panel | Aluminum - 6022 - T4 | 2.50 | 0.46 |
| 7306-2300-192 | Tail lamp close out panel | Aluminum - 6022 - T4 | | 0.09 |
| Sub-total | | | | 6.12 |
| Roof and Header | | | | |
| 7306-2200-109 | Roof panel | Aluminum - 6022 - T4 | 1.20 | 9.05 |
| 7306-2000-215 | Rear roof side rail inner - left | Aluminum - 6022 - T6 | 2.00 | 0.78 |

| | | | | |
|--|------------------------------------|--|------------------|--------------|
| 7306-2000-171 | Front roof side rail inner - left | Aluminum - 6022 - T6 | 2.00 | 0.40 |
| 7306-2000-216 | Rear roof side rail inner - right | Aluminum - 6022 - T6 | 2.00 | 0.78 |
| 7306-2000-172 | Front roof side rail inner - right | Aluminum - 6022 - T6 | 2.00 | 0.40 |
| 7306-2100-101 | Front header | Aluminum - 6022 - T4 | 2.50 | 1.81 |
| 7306-2100-103 | Center header | Aluminum - 6022 - T4 | 2.50 | 1.65 |
| 7307-2100-104 | Rear header | Aluminum - 6022 - T6 | 2.50 | 1.99 |
| | | | Sub-total | 16.86 |
| Left-side D-Pillar Assembly | | | | |
| 7307-2110-179 | Liftgate reinforcement | Aluminum - 6022 - T6 | 2.50 | 1.14 |
| 7307-2110-105 | D-pillar inner | Aluminum - 6022 - T6 | 2.50 | 1.47 |
| 7307-2110-177 | Quarter panel inner | Aluminum - 6022 - T6 | 2.50 | 1.18 |
| | | | Sub-total | 3.79 |
| Right-side D-Pillar Assembly | | | | |
| 7307-2120-180 | Liftgate reinforcement | Aluminum - 6022 - T6 | 2.50 | 1.14 |
| 7307-2120-106 | D-pillar inner | Aluminum - 6022 - T6 | 2.50 | 1.47 |
| 7307-2120-178 | Quarter panel inner | Aluminum - 6022 - T6 | 2.50 | 1.18 |
| | | | Sub-total | 3.79 |
| Shotgun Closeouts | | | | |
| 7305-1900-159 | Shotgun closeout panel - left | Aluminum - 6022 - T4 | 2.50 | 0.06 |
| 7305-1900-160 | Shotgun closeout panel - right | Aluminum - 6022 - T4 | 2.50 | 0.06 |
| | | | Sub-total | 0.12 |
| Lower Left A-Pillar Outer Assembly | | | | |
| 7305-1930-169 | Shotgun outer panel | Aluminum - 6013 - T6 | 2.00 | 0.94 |
| 7305-1930-187 | Lower panel | Aluminum - 6061 - T6 | 3.00 | 3.33 |
| 7305-1930-171 | Upper hinge reinforcement | Mild Steel | 3.00 | 0.15 |
| 7305-1930-173 | Lower hinge reinforcement | Mild Steel | 3.00 | 0.12 |
| | | | Sub-total | 4.54 |
| Lower Right A-Pillar Outer Assembly | | | | |
| 7305-1940-170 | Shotgun outer panel | Aluminum - 6013 - T6 | 2.00 | 0.94 |
| 7305-1940-188 | Lower panel | Aluminum - 6061 - T6 | 3.00 | 3.33 |
| 7305-1940-184 | Upper hinge reinforcement | Mild Steel | 3.00 | 0.15 |
| 7305-1940-186 | Lower hinge reinforcement | Mild Steel | 3.00 | 0.12 |
| | | | Sub-total | 4.54 |
| Right Door Aperature Assembly | | | | |
| Right B-Pillar Sub-Assembly | | | | |
| 7306-1920-190 | Upper A-pillar outer panel | Aluminum - 6022 - T4 | 2.50 | 1.33 |
| 7306-1920-192 | Outer roof side rail | Aluminum - 6013 - T6 | 2.50 | 0.86 |
| 7306-1920-194 | C-pillar striker reinforcement | Mild Steel | 3.00 | 0.30 |
| 7306-1920-196 | C-pillar outer | Aluminum - 6013 - T6 | 2.50 | 3.24 |
| | | | Sub-total | 5.72 |
| Right B-Pillar Outer Sub-Assembly | | | | |
| 7306-1924-002 | Lower B-pillar outer | SSAB Tunplatt Docol® 1400 DP High-strength Steel | 1.40 | 5.51 |
| 7306-1924-004 | Upper B-pillar outer | Aluminum - 6022 - T4 | 2.50 | 0.49 |
| 7306-1924-006 | Upper, inner reinforcement | Mild Steel | 3.00 | 0.49 |
| 7306-1924-008 | Middle, inner reinforcement | Mild Steel | 3.00 | 0.23 |
| 7306-1924-010 | Lower, inner reinforcement | Mild Steel | 3.00 | 0.56 |
| | | | Sub-total | 7.27 |

| Right B-Pillar Inner Sub-Assembly | | | | |
|--|---------------------------------|---|------------------|-------------|
| 7306-1926-012 | Lower B-pillar inner | SSAB Tunnpilat Docol® 1400 DP High-strength Steel | 1.40 | 2.72 |
| 7306-1915-001 | Beltline reinforcement plate | Mild Steel | 3.18 | 0.06 |
| 7306-1915-002 | B-pillar reinforcement | Terocore structural | 3.00 | 1.53 |
| 7306-1926-014 | B-pillar, upper, inner | Aluminum - 6013 - T6 | 2.00 | 0.18 |
| | | | Sub-total | 4.49 |
| Left Door Aperature Assembly | | | | |
| Left B-Pillar Sub-Assembly | | | | |
| 7306-1910-189 | Upper A-pillar outer panel | Aluminum - 6022 - T4 | 2.50 | 1.33 |
| 7306-1910-191 | Outer roof side rail | Aluminum - 6013 - T6 | 2.50 | 0.86 |
| 7306-1910-193 | C-pillar striker reinforcement | Mild Steel | 3.00 | 0.30 |
| 7306-1910-195 | C-pillar outer | Aluminum - 6013 - T6 | 2.50 | 3.24 |
| | | | Sub-total | 5.72 |
| Left B-Pillar Outer Sub-Assembly | | | | |
| 7306-1913-001 | Lower B-pillar outer | SSAB Tunnpilat Docol® 1400 DP High-strength Steel | 1.40 | 5.51 |
| 7306-1913-003 | Upper B-pillar outer | Aluminum - 6022 - T4 | 2.50 | 0.49 |
| 7306-1913-005 | Upper, inner reinforcement | Mild Steel | 3.00 | 0.49 |
| 7306-1913-007 | Middle, inner reinforcement | Mild Steel | 3.00 | 0.23 |
| 7306-1913-009 | Lower, inner reinforcement | Mild Steel | 3.00 | 0.56 |
| | | | Sub-total | 7.27 |
| Left B-Pillar Inner Sub-Assembly | | | | |
| 7306-1915-011 | Lower B-pillar inner | SSAB Tunnpilat Docol® 1400 DP High-strength Steel | 1.40 | 2.72 |
| 7306-1915-001 | Beltline reinforcement plate | Mild Steel | 3.18 | 0.06 |
| 7306-1915-003 | B-pillar reinforcement | Terocore structural | 3.00 | 1.53 |
| 7306-1915-013 | B-pillar, upper, inner | Aluminum - 6013 - T6 | 2.00 | 0.18 |
| | | | Sub-total | 4.49 |
| Cowl | | | | |
| 7305-1800-145 | Upper cowl panel | Magnesium - AM60 | 4.00 | 2.52 |
| 7305-1700-147 | Cowl support | Aluminum - 6022 - T4 | 1.50 | 1.86 |
| | | | Sub-total | 4.38 |
| Left Dash Transmission Assembly | | | | |
| 7305-1530-221 | Dash-transmission reinforcement | Aluminum - 6013 - T6 | 3.00 | 1.55 |
| 7305-1530-223 | Dash-transmission insert | Aluminum - 6013 - T6 | 3.00 | 0.09 |
| | | | Sub-total | 1.64 |
| Right Dash Transmission Assembly | | | | |
| 7305-1520-222 | Dash-transmission reinforcement | Aluminum - 6013 - T6 | 3.00 | 1.55 |
| 7305-1520-224 | Dash-transmission insert | Aluminum - 6013 - T6 | 3.00 | 0.09 |
| | | | Sub-total | 1.64 |
| Rear End Panel Assembly | | | | |
| 7307-1510-111 | Outer panel | Aluminum - 6022 - T4 | 2.50 | 2.13 |
| 7307-1510-117 | Inner panel | Aluminum - 6022 - T4 | 2.50 | 3.61 |
| | | | Sub-total | 5.74 |
| Rear Crossmember Assembly | | | | |
| 7307-1410-119 | Rear compartment crossmember | Aluminum - 6061-T6 | 3.00 | 4.26 |
| 7307-1410-120 | Hanger bracket extrusion | Aluminum - 6061-T6 | 3.00 | 0.35 |

| | | | | |
|--|---|--------------------|----------|--------------|
| Sub-total | | | | 4.61 |
| Left Front Wheelhouse Assembly | | | | |
| 7305-1310-151 | Front shock tower | Aluminum - 356-T6 | 3.00 | 1.09 |
| 7305-1310-161 | Front wheelhouse panel | Magnesium - AM60 | 6.00 | 2.05 |
| Sub-total | | | | 3.14 |
| Right Front Wheelhouse Assembly | | | | |
| 7305-1320-152 | Front shock tower | Aluminum - 356-T6 | 3.00 | 1.09 |
| 7305-1320-162 | Front wheelhouse panel | Magnesium - AM60 | 6.00 | 2.05 |
| Sub-total | | | | 3.14 |
| Rear Seat Pan Assembly | | | | |
| 7306-1200-113 | Rear seat panel floor | Aluminum - 6022-T4 | 1.50 | 3.98 |
| 7306-1200-111 | Seatbelt anchorage plate - right and left | Aluminum - 6022-T4 | 3.00 | 0.10 |
| 7307-1200-218 | Rear frame rail outer transition - right | Aluminum - 356-T6 | 3.00 | 4.28 |
| 7307-1200-217 | Rear frame rail outer transition - left | Aluminum - 356-T6 | 3.00 | 4.28 |
| Sub-total | | | | 12.65 |
| Rear Center Seat Riser Assembly | | | | |
| 7306-1110-101 | Rear center seat riser | Aluminum - 6022-T4 | 1.50 | 1.63 |
| 7306-1110-103 | Rear seat floor reinforcement - left | Aluminum - 6022-T4 | 2.50 | 0.28 |
| 7306-1000-176 | Rear seat riser - right | Aluminum - 6022-T4 | 1.50 | 0.44 |
| 7306-1000-175 | Rear seat riser - left | Aluminum - 6022-T4 | 1.50 | 0.44 |
| Sub-total | | | | 2.78 |
| Rear Frame Rail Assembly | | | | |
| 7307-1000-139 | Rear frame rail - right and left | Aluminum - 6061-T6 | 2.5/2.75 | 3.81 |
| 7307-1000-138 | Rear frame rail mounting plate - right and left | Aluminum - 6022-T4 | 2.50 | 0.28 |
| Sub-total | | | | 4.09 |
| Right Front Frame Rail Assembly | | | | |
| 7307-1020-136 | Front frame rail | Aluminum - 6061-T6 | 2.5/2.75 | 1.54 |
| 7307-1020-224 | Front frame rail mounting plate | Aluminum - 6022-T4 | 2.00 | 0.18 |
| Sub-total | | | | 1.71 |
| Right Front Rail Mount Sub-Assembly | | | | |
| 7307-1011-001 | Front rail mount | Aluminum - 6022-T4 | 2.50 | 0.09 |
| 7307-1011-003 | Front rail mount cvr - left and right | Aluminum - 6022-T4 | 2.50 | 0.12 |
| Sub-total | | | | 0.21 |
| Left Front Frame Rail Assembly | | | | |
| 7307-1010-135 | Front frame rail | Aluminum - 6061-T6 | 2.5/2.75 | 1.54 |
| 7307-1010-223 | Front frame rail mounting plate | Aluminum - 6022-T4 | 2.00 | 0.18 |
| Sub-total | | | | 1.71 |
| Left Front Rail Mount Sub-Assembly | | | | |
| 7307-1011-001 | Front rail mount | Aluminum - 6022-T4 | 2.50 | 0.09 |
| 7307-1011-003 | Front rail mount cvr - left and right | Aluminum - 6022-T4 | 2.50 | 0.12 |
| Sub-total | | | | 0.21 |
| Transitions | | | | |
| 7305-1200-210 | Front frame rail outer transition - right | Aluminum - 356-T6 | 3.00 | 3.11 |
| 7305-1200-209 | Front frame rail outer transition - left | Aluminum - 356-T6 | 3.00 | 3.11 |
| 7305-0900-138 | Front frame rail inner transition - right | Aluminum - 356-T6 | 3.00 | 3.07 |

| | | | | |
|--|--|----------------------|---------|--------------|
| 7305-0900-137 | Front frame rail inner transition - left | Aluminum - 356-T6 | 3.00 | 3.07 |
| 7307-0900-142 | Rear frame rail inner transition - right | Aluminum - 356-T6 | 3.00 | 3.41 |
| 7307-0900-141 | Rear frame rail inner transition - left | Aluminum - 356-T6 | 3.00 | 3.41 |
| Sub-total | | | | 19.18 |
| Small Floor Crossmember Assembly | | | | |
| 7306-0830-124 | Small outer extrusion - right and left | Aluminum - 6061-T6 | 3.00 | 0.61 |
| 7306-0830-125 | Small floor crossmember - right and left | Aluminum - 6061-T6 | 2.50 | 4.89 |
| 7306-0830-126 | Small inner extrusion - right and left | Aluminum - 6061-T6 | 3.00 | 0.54 |
| Sub-total | | | | 6.04 |
| Large Floor Crossmember Assembly | | | | |
| 7306-0840-010 | Large outer extrusion - right and left | Aluminum - 6061-T6 | 3.00 | 0.51 |
| 7306-0840-011 | Large floor crossmember - right and left | Aluminum - 6061-T6 | 2.50 | 2.62 |
| 7306-0840-012 | Large inner extrusion - right and left | Aluminum - 6061-T6 | 3.00 | 0.17 |
| 7306-0850-000 | Fore and aft extrusion - right and left | Aluminum - 6061-T6 | 3.00 | 1.89 |
| 7306-0860-000 | Center tunnel bracket | Aluminum - 6061-T6 | 2.50 | 0.33 |
| Sub-total | | | | 5.51 |
| Dash Panel | | | | |
| 7305-1400-143 | Upper dash panel | Magnesium - AM60 | 3.00 | 3.69 |
| 7305-1400-144 | Lower dash panel | Magnesium - AM60 | 3.00 | 5.37 |
| 7305-1600-149 | Dash panel reinforcement | Magnesium - AM60 | 3.0/2.0 | 2.85 |
| Sub-total | | | | 11.91 |
| Miscellaneous Panels and Reinforcements | | | | |
| 7307-1600-183 | Rear wheelhouse outer panel - left | Magnesium - AM60 | 3.00 | 2.02 |
| 7307-1600-184 | Rear wheelhouse outer panel - right | Magnesium - AM60 | 3.00 | 1.86 |
| 7307-1600-213 | Rear closeout panel - left | Aluminum - 6022 - T4 | 1.50 | 0.49 |
| 7307-1600-214 | Rear closeout panel - right | Aluminum - 6022 - T4 | 1.50 | 0.49 |
| 7305-1500-157 | Shotgun inner panel - left | Aluminum - 6013 - T6 | 2.00 | 1.05 |
| 7305-1500-158 | Shotgun inner panel - right | Aluminum - 6013 - T6 | 2.00 | 1.05 |
| 7305-1500-197 | A-pillar inner reinforcement panel - left | Aluminum - 6022 - T4 | 2.00 | 0.22 |
| 7305-1500-198 | A-pillar inner reinforcement panel - right | Aluminum - 6022 - T4 | 2.00 | 0.22 |
| 7305-1400-154 | Lower A-pillar inner - right | Aluminum - 6022 - T4 | 2.00 | 0.40 |
| 7305-1400-153 | Lower A-pillar inner - left | Aluminum - 6022 - T4 | 2.00 | 0.40 |
| 7307-1400-164 | Rear wheelhouse inner - right | Aluminum - 6022 - T4 | 2.50 | 3.95 |
| 7307-1400-163 | Rear wheelhouse inner - left | Aluminum - 6022 - T4 | 2.50 | 3.96 |
| 7305-1500-228 | Lower A-pillar inner reinforcement - right | Aluminum - 6022-T4 | 2.00 | 0.17 |
| 7305-1500-227 | Lower A-pillar inner reinforcement - left | Aluminum - 6022-T4 | 2.00 | 0.17 |
| 7307-1500-168 | Shock tower reinforcement - right | Aluminum - 6022-T4 | 2.50 | 0.61 |
| 7307-1500-167 | Shock tower reinforcement - left | Aluminum - 6022-T4 | 2.50 | 0.61 |
| 7305-1300-156 | Upper A-pillar inner - right | Aluminum - 6022-T4 | 2.00 | 1.60 |
| 7305-1300-155 | Upper A-pillar inner - left | Aluminum - 6022-T4 | 2.00 | 1.60 |
| 7305-1300-166 | Rear shock tower - right | Aluminum - 356-T6 | 3.00 | 2.15 |
| 7305-1300-165 | Rear shock tower - left | Aluminum - 356-T6 | 3.00 | 2.15 |
| 7306-0820-124 | Rocker sill extension - right | Aluminum - 6061-T6 | 2.0/2.5 | 5.82 |
| 7306-0810-123 | Rocker sill extension - left | Aluminum - 6061-T6 | 2.0/2.5 | 5.82 |
| Sub-total | | | | 36.77 |

Table 4.5.5.b below shows a condensed summary of the full BOM table above, breaking out the various body components and subsystems. The table exemplifies how an overall

37-percent mass (141 kg) reduction from the baseline Venza was achieved while individual components had revised mass reductions. For example, the underbody and floor area went from the baseline steel to a mostly aluminum structure and resulted in an 18-percent (21 kg) reduction. The dash panel area was constructed out of magnesium instead of the baseline steel, which resulted in a 30-percent (5 kg) mass reduction. The new aluminum roof structure was 39-percent lighter (7.9 kg) than the conventional steel one. Within the vehicle body sides, each aluminum A-pillar resulted in a 50-percent (9.1 kg) mass reduction and each HSS B-pillar resulted in a 53-percent (19.7 kg) mass reduction from the conventional steel versions.

Table 4.5.5.b: Phase 2 HD Vehicle Body Structure

| System | Subsystem | Standard Venza (kg) | Percent of Body Structure | Material Mass (kg) | | | | | Revised Structure Total (kg) | Percent reduction from baseline | Piece Cost Relative to Venza |
|----------------|--|---------------------|---------------------------|--------------------|------------|-----------|-----------|-----------|------------------------------|---------------------------------|------------------------------|
| | | | | Steel | Al | Mg | Composite | Other | | | |
| Body complete | | 403.24 | | | | | | | 260.8 | 35% | |
| | Windshield wiper system | 9.15 | | - | - | - | - | - | 8 | 13% | |
| | Body exterior trim items | 11.59 | | - | - | - | - | - | 6.55 | 43% | |
| Body structure | | 382.5 | | | | | | | 241.8 | 39% | |
| | Underbody & floor | 113.65 | 30% | - | 79.9 | - | 12.9 | - | 92.7 | 18% | 110% |
| | Dash panel | 15.08 | 4% | - | - | 11.9 | - | - | 11.9 | 21% | 141% |
| | Front structure & radiator crossmember | 25.15 | 7% | - | 11.6 | 5.5 | - | - | 17.1 | 32% | 167% |
| | Body side LH | 65.22 | 17% | 10.1 | 16.5 | 1.9 | - | 1.5 | 33.3 | 49% | 117% |
| | Body side RH | 65.22 | 17% | 10.1 | 16.5 | 1.9 | - | 1.5 | 33.2 | 49% | 117% |
| | Roof | 27.83 | 7% | - | 16.9 | - | - | - | 16.9 | 39% | 298% |
| | Internal Structure | 58.35 | 15% | - | 24.6 | - | - | - | 24.6 | 58% | |
| | NVH | 8 | 2% | - | - | - | - | - | 8 | 0% | 100% |
| | Paint | 4 | 1% | - | - | - | - | - | 4 | 0% | 100% |
| Total | | 382.5 | | 18 | 167 | 27 | 11 | 12 | 241.8 | 37% | 160% |

The more prominent changes made between Phase 1 and 2 in order to refine the vehicle to meet crash test standards are shown in Table 4.5.5.c below. The table lists the baseline Venza, original Phase 1 HD design, and updated Phase 2 design. Several changes were made from Phase 1 to Phase 2 such as modifying the B-pillar from aluminum to dual-phase 1400 HSS because of roof crush and side impact standards. The Phase 1 floor contained aluminum, magnesium, and significant amounts of composite material, but the Phase 2 floor has moved to a more aluminum-intensive composite structure for manufacturing reasons.

Magnesium was used extensively in the front structure, roof, and A-pillar design of the Phase 1 HD design, but the metal proved too brittle to meet crash standards. The Phase 2 HD model uses primarily aluminum for all these structures. The lower A-pillar inner however, is integrated into the magnesium dash casting and the move to an aluminum A-

pillar allowed for an increase in cross-sectional area to stiffen the body and increase torsional stiffness. Changes were made to the C-pillar design as well, moving from a magnesium structure to an aluminum and steel structure for the same reasons as the A-pillar.

Table 4.5.5.c: Summary of changes from Phase 1 HD to Phase 2 HD

| Body Subsystem | Venza (kg) | Phase 1 HD (kg) | Phase 2 HD (kg) | Phase 2 Material Shift | Reason for Change |
|--|------------|-----------------|-----------------|---------------------------------|----------------------------|
| Underbody/Floor | 113.7 | 83.8 | 92.7 | Mix to mostly aluminum | Manufacturing |
| Front structure and radiator crossmember | 25.2 | 18.6 | 17.1 | Magnesium to aluminum | Frontal impact, FMVSS 208 |
| Body-side A-pillar | 18.2 | 12.8 | 9.1 | Magnesium to aluminum | Roof crush, frontal impact |
| Body-side B-pillar | 37.19 | 17.13 | 17.48 | Magnesium to aluminum and HSS | Roof crush, side impact |
| C-pillar | 12.8 | 10.2 | 3.5 | Magnesium to steel and aluminum | Roof crush, side impact |
| Roof | 27.8 | 16.8 | 16.9 | Magnesium to aluminum | Roof crush |

Figure 4.5.5.a below lists all masses in kg.

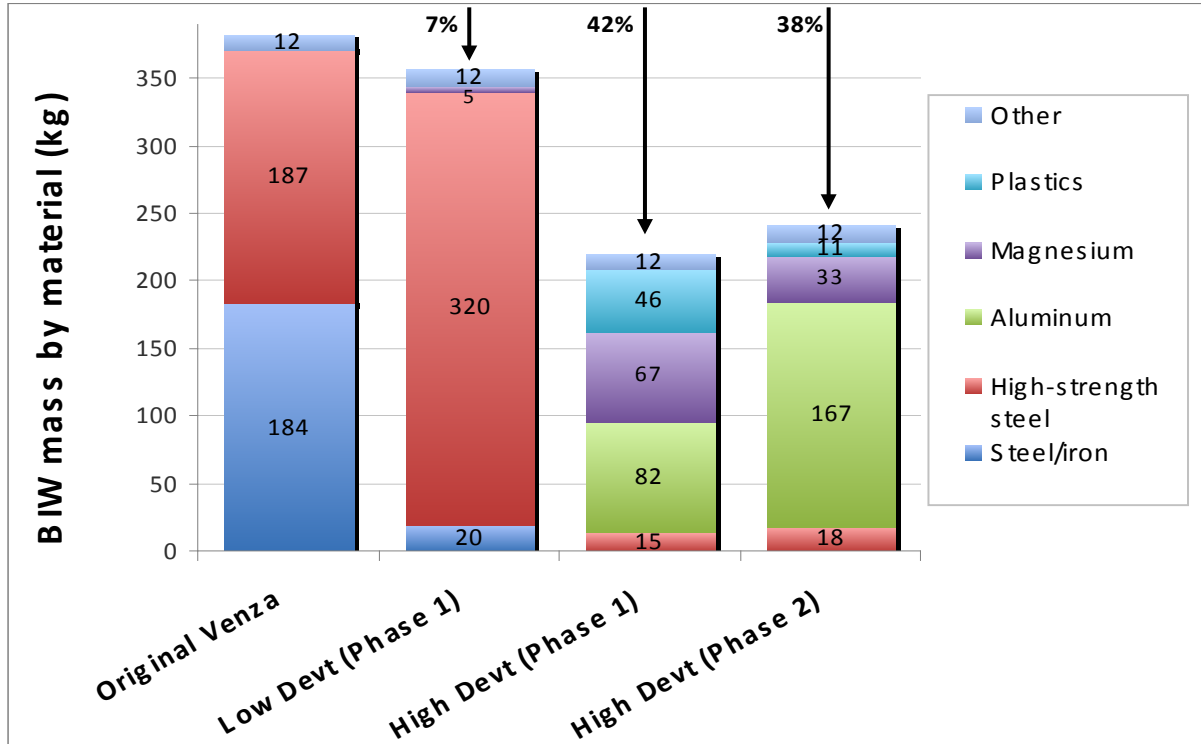

Figure 4.5.5.a: Venza, Phase 1, and Phase 2 vehicle body structure by material

Table 4.5.5.d below shows a comparison of all system masses for the baseline 2009 Venza, the Phase 1 Low Development and High Development models and the Phase 2 model. The bumper mass for the Phase 2 model was adjusted from 15.95 kg to 20.17 kg to adjust for the increased front and rear bumper masses. These systems were designed in CAD as part of the Phase 2 study and were engineered as part of the energy absorbing structure. The bumper beam masses increased by 1.05 kg (front) and 1.39 kg (rear). The bumper crush cans added an additional 0.86 kg at the front and 0.92 kg at the rear. The total mass of the Phase 2 model was 1173 kg; this mass was used as the basis for all analyses performed as part of this study.

Table 4.5.5.d: Venza, Phase 1, and Phase 2 system masses

| Area/System | Venza Baseline Mass (kg) | Phase 1 Low Development Mass (kg) | Phase 1 High Development Mass (kg) | Phase 2 High Development Mass (kg) |
|-----------------------------------|--------------------------|-----------------------------------|------------------------------------|------------------------------------|
| Body-in-white | 382.5 | 357.4 | 221.1 | 241.8 |
| Closures/Fenders | 143.02 | 107.6 | 83.98 | 83.98 |
| Bumpers | 17.95 | 15.95 | 15.95 | 20.17 |
| Thermal | 9.25 | 9.25 | 9.25 | 9.25 |
| Electrical | 23.6 | 16.68 | 15.01 | 15.01 |
| Interior | 250.6 | 182.0 | 153 | 153 |
| Lighting | 9.9 | 9.9 | 9.9 | 9.9 |
| Suspension/Chassis | 378.9 | 275.5 | 217.0 | 217.0 |
| Glazing | 43.71 | 43.7 | 43.71 | 43.71 |
| Misc. | 30.1 | 22.9 | 22.9 | 22.9 |
| Powertrain | 410.16 | 356.2 | 356.2 | 356.2 |
| Total excluding powertrain | 1290 | 1041 | 795 | 817 |
| Reduction from baseline | - | 19% | 39% | 38% |
| Total including powertrain | 1700 | 1397 | 1151 | 1173 |
| Reduction from baseline | - | 18% | 32% | 31% |

The baseline and Phase 1 mass information was published in 2010 by the International Council on Clean Transportation in a report titled: An Assessment of Mass Reduction Opportunities for a 2017-2020 Model Year Vehicle Program. The link to this study is:
http://www.theicct.org/pubs/Mass_reduction_final_2010.pdf

Figure 4.5.5.b below shows the total vehicle material utilization by mass for the baseline, Phase 1, and Phase 2 models.

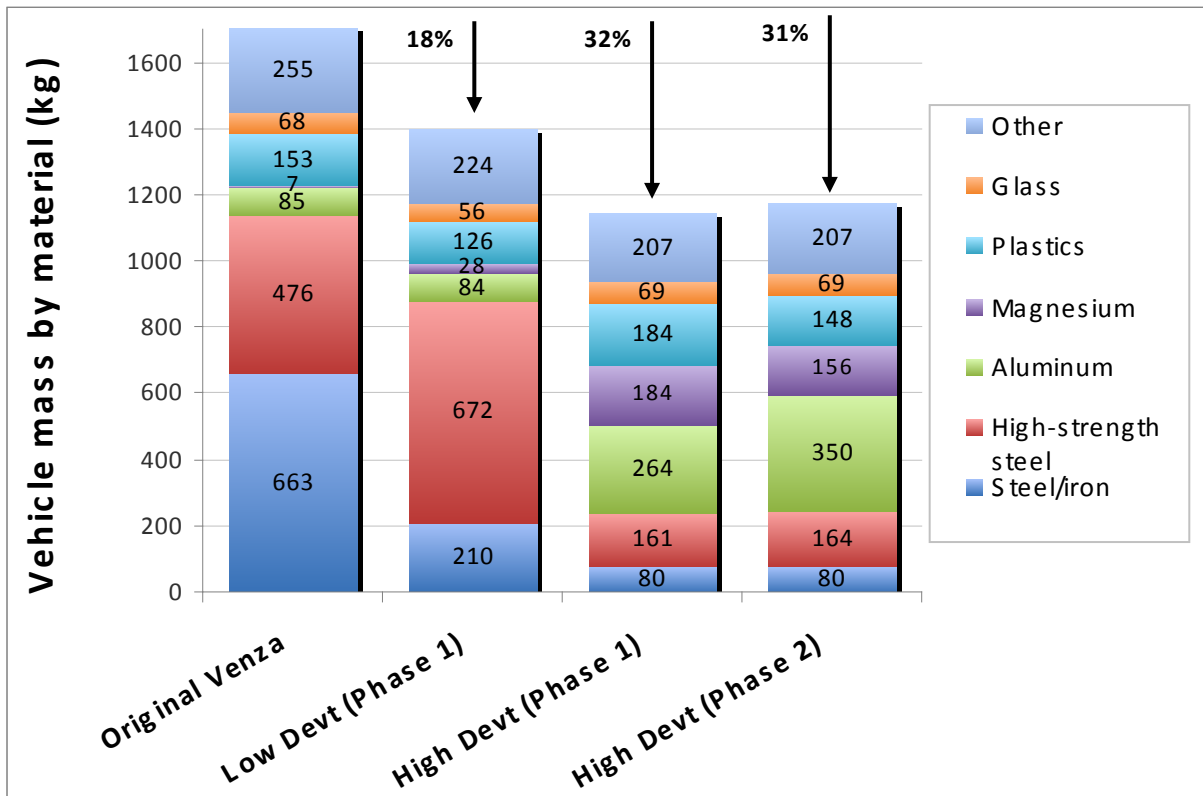

Figure 4.5.5.b: Venza, Phase 1, and Phase 2 full vehicle material composition

4.5.5.1 Closures Bill of Materials

A separate BOM was constructed for just the fully engineered closures. The total weight increased to 90.4 kg from the estimated 84.0 kg due to changes in material from magnesium to aluminum. The full BOM is listed in Table 4.5.5.1.a below.

Table 4.5.5.1.a: Closures BOM

| Part Number | Part Name | Material | Thickness (mm) | Mass (kg) |
|-----------------|---|--------------------|----------------|-------------|
| Closures | | | | 90.4 |
| Liftgate | | | | |
| 7308-2610-001 | Liftgate inner | Magnesium - AM60 | 3.00 | 7.318 |
| 7308-2610-002 | Liftgate outer | Aluminum - 6063-T4 | 1.20 | 5.673 |
| 7308-2610-003 | Panel - Spoiler | PPO+PA Noryl GTX | 3.00 | 1.034 |
| 7308-2610-004 | Liftgate bracket – gas strut anchor - inner | Aluminum - 6063-T4 | 3.00 | 0.036 |
| 7308-2610-005 | Bracket – hinge upper | Aluminum - 6063-T4 | 3.0 | 0.021 |
| 7308-2610-005 | Bracket – liftgate hinge base | Aluminum - 6063-T4 | 3.0 | 0.021 |

| | | | | |
|------------------------|------------------------------------|--------------------|------------------|--------------|
| | | | Sub-total | 14.10 |
| Door Front – LH | | | | |
| 7308-2710-001 | Panel - Door outer - LH | Aluminum - 6063-T4 | 1.2 | 3.28 |
| 7308-2810-002 | Panel - Door inner - LH | Magnesium - AM60 | 3.0 | 4.18 |
| 7308-2810-003 | Beam – Reinf't Front Door | HSS-950 | 1.4 | 1.381 |
| 7308-2810-004 | Bracket- Frt. Dr. Hinge support | HSS-950 | 1.4 | 0.4951 |
| 7308-2810-005 | Beam – Reinf.-Frt. Dr. outer | HSS-950 | 1.4 | 0.4917 |
| 7308-2810-006 | Striker Asm.-Striker Plate | LCS | 3.0 | 0.0666 |
| 7308-2810-007 | Hinge Asm. – Door upper | LCS | 5.0 | 0.601 |
| 7308-2810-008 | Hinge plate – outer - upper | LCS | 5.0 | 0.5448 |
| 7308-2810-009 | Hinge plate – inner - upper | LCS | 4.0 | 0.1026 |
| 7308-2810-010 | Hinge Asm. – Door lower | LCS | 5.0 | 0.601 |
| 7308-2810-011 | Hinge plate – outer - lower | LCS | 5.0 | 0.5448 |
| 7308-2810-012 | Hinge plate – inner - lower | LCS | 4.0 | 0.1026 |
| 7308-2810-013 | Striker – Front Door latch reinf't | HSS - 950 | 1.5 | 0.361 |
| 73082810-014 | Panel – Insert Frt Door | PPO - Unfilled | 3.0 | 0.9276 |
| | | | Sub-total | 13.68 |
| Door Front – RH | | | | |
| 7308-2710-001 | Panel - Door outer - RH | Aluminum - 6063-T4 | 1.2 | 3.28 |
| 7308-2810-002 | Panel - Door inner - RH | Magnesium - AM60 | 3.0 | 4.18 |
| 7308-2810-003 | Beam – Reinf't Front Door | HSS-950 | 1.4 | 1.381 |
| 7308-2810-004 | Bracket- Frt. Dr. Hinge support | HSS-950 | 1.4 | 0.4951 |
| 7308-2810-005 | Beam – Reinf.-Frt. Dr. outer | HSS-950 | 1.4 | 0.4917 |
| 7308-2810-006 | Striker Asm.-Striker Plate | LCS | 3.0 | 0.0666 |
| 7308-2810-007 | Hinge Asm. – Door upper | LCS | 5.0 | 0.601 |
| 7308-2810-008 | Hinge plate – outer - upper | LCS | 5.0 | 0.5448 |
| 7308-2810-009 | Hinge plate – inner - upper | LCS | 4.0 | 0.1026 |
| 7308-2810-010 | Hinge Asm. – Door lower | LCS | 5.0 | 0.601 |
| 7308-2810-011 | Hinge plate – outer - lower | LCS | 5.0 | 0.5448 |
| 7308-2810-012 | Hinge plate – inner - lower | LCS | 4.0 | 0.1026 |
| 7308-2810-013 | Striker – Front Door latch reinf't | HSS - 950 | 1.5 | 0.361 |
| 73082810-014 | Panel – Insert Frt Door | PPO - Unfilled | 3.0 | 0.9276 |
| | | | Sub-total | 13.68 |
| Door Rear - LH | | | | |
| 7308-2910-001 | Panel - Door rear outer - LH | Aluminum - 6063-T4 | 1.2 | 2.871 |
| 7308-2910-002 | Panel - Door rear inner - LH | Magnesium AM60 | 3.0 | 4.3409 |
| 7308-2910-003 | Beam – Reinf't Rear Door | HSS - 950 | 1.4 | 2.127 |
| 7308-2910-004 | Hinge – Ft Dr Lwr | LCS | 5.0 | 0.601 |
| 7308-2910-005 | Striker Asm.-Striker Plate | LCS | 3.0 | 0.0666 |
| 7308-2910-006 | Hinge Asm. – Door upper | LCS | 5.0 | 0.601 |
| 7308-2910-007 | Hinge plate – outer - upper | LCS | 5.0 | 0.5448 |
| 7308-2910-008 | Hinge plate – inner - upper | LCS | 4.0 | 0.1026 |
| 7308-2910-009 | Hinge Asm. – Door lower | LCS | 5 | 0.601 |
| 7308-2910-010 | Hinge plate – outer - lower | LCS | 5.0 | 0.5448 |
| 7308-2910-011 | Hinge plate – inner - lower | LCS | 4.0 | 0.1026 |
| 7308-2910-012 | Panel – Insert Frt Door | PPO - Unfilled | 3.0 | 0.6951 |
| 7308-2910-013 | Striker – latch reinf't | Aluminum 6061 T4 | 1.4 | 0.256 |

| | | | | |
|--------------------------------|---------------------------------|----------------------|------------------|---------------|
| 7308-2910-014 | Bracket – rr dr hinge support | Aluminum 6063 T4 | 2.0 | 0.263 |
| 7308-2910-015 | Reinf't – rr dr outer | Aluminum 6063 T4 | 2.0 | 0.649 |
| 7308-2910-016 | Reinf't – rr dr inner | Aluminum 6063 T4 | 2.0 | 0.649 |
| | | | Sub-total | 12.58 |
| Door Rear - RH | | | | |
| 7308-3010-001 | Panel - Door rear outer - LH | Aluminum - 6063-T4 | 1.2 | 2.871 |
| 7308-3010-002 | Panel - Door rear inner - LH | Magnesium AM60 | 3.0 | 4.3409 |
| 7308-3010-003 | Beam – Reinf't Rear Door | HSS - 950 | 1.4 | 2.127 |
| 7308-3010-004 | Hinge – Ft Dr Lwr | LCS | 2.5/2.0 | 0.364 |
| 7308-3010-005 | Striker Asm.-Striker Plate | LCS | 3.0 | 0.0666 |
| 7308-3010-006 | Hinge Asm. – Door upper | LCS | 5.0 | 0.601 |
| 7308-3010-007 | Hinge plate – outer - upper | LCS | 5.0 | 0.5448 |
| 7308-3010-008 | Hinge plate – inner - upper | LCS | 4.0 | 0.1026 |
| 7308-3010-009 | Hinge Asm. – Door lower | LCS | 5 | 0.601 |
| 7308-3010-010 | Hinge plate – outer - lower | LCS | 5.0 | 0.5448 |
| 7308-3010-011 | Hinge plate – inner - lower | LCS | 4.0 | 0.1026 |
| 7308-3010-012 | Panel – Insert Frt Door | PPO - Unfilled | 3.0 | 0.6951 |
| 7308-3010-013 | Striker – latch reinf't | Aluminum 6061 T4 | 1.4 | 0.256 |
| 7308-3010-014 | Bracket – rr dr hinge support | Aluminum 6063 T4 | 2.0 | 0.263 |
| 7308-3010-015 | Reinf't – rr dr outer | Aluminum 6063 T4 | 2.0 | 0.649 |
| 7308-3010-016 | Reinf't – rr dr inner | Aluminum 6063 T4 | 2.0 | 0.649 |
| | | | Sub-total | 12.58 |
| Front Fender Outer - LH | | | | |
| 7308-3110-001 | Panel - Front Fender Outer - LH | Aluminum - 6063 - T4 | 1.2 | 4.756 |
| 7308-3110-002 | Reinf't – Fender mount at lamp | Aluminum - 6022 - T4 | 2.5 | 0.662 |
| 7308-3110-003 | Brkt – Fender mount mid-upr | Aluminum - 6022 - T4 | 2.5 | 0.048 |
| 7308-3110-004 | Brkt – Fender mount upr | Aluminum - 6022 - T4 | 2.5 | 0.07 |
| 7308-3110-005 | Brkt – Fender mount lwr | Aluminum - 6022 - T4 | 2.5 | 0.043 |
| 7308-3110-006 | Brkt – Fender mount - upr rear | Aluminum - 6022 - T4 | 2.5 | 0.053 |
| | | | Sub-total | 5.63 |
| Front Fender Outer - RH | | | | |
| 7308-3210-001 | Panel - Front Fender Outer - LH | Aluminum - 6063 - T4 | 1.2 | 4.756 |
| 7308-3210-002 | Reinf't – Fender mount at lamp | Aluminum - 6022 - T4 | 2.5 | 0.662 |
| 7308-3210-003 | Brkt – Fender mount mid-upr | Aluminum - 6022 - T4 | 2.5 | 0.048 |
| 7308-3210-004 | Brkt – Fender mount upr | Aluminum - 6022 - T4 | 2.5 | 0.07 |
| 7308-3210-005 | Brkt – Fender mount lwr | Aluminum - 6022 - T4 | 2.5 | 0.043 |
| 7308-3210-006 | Brkt – Fender mount - upr rear | Aluminum - 6022 - T4 | 2.5 | 0.053 |
| | | | Sub-total | 5.63 |
| Hood | | | | |
| 7308-3310-001 | Panel - Hood outer | Aluminum - 6063 - T4 | 1.2 | 4.113 |
| 7308-3310-002 | Panel - Hood inner | Aluminum - 6063 - T4 | 2.50 | 8.11 |
| 7308-3310-003 | Hinge – hood (2x) | Aluminum - 6022 - T4 | 2.50 | 0.26 |
| | | | Sub-total | 12.483 |

4.5.6. Vehicle Manufacturing

A vehicle assembly process was developed to ensure that the BIW could be assembled and mass-produced in a cost-effective manner. EBZ Engineering – which designs plants for VW, Audi, Porsche, Jaguar Land Rover, BMW, Ford of Europe, Tata, Magna, and Opel – completed the plant design for Lotus Engineering. The EBZ-designed manufacturing process was used to drive the part design; all parts were analyzed as a function of the build flow to ensure part-to-part compatibility as well as compatibility with the fixturing and joining processes. While the assembly techniques used in this study were carried into the manufacturing process, some OEMs may be reluctant to begin adopting new bonding or manufacturing methods such as structural adhesives. Automotive manufacturing engineers are typically conservative due to the risks associated with new processes – if it should fail, the whole plant will come offline for some time. However, as noted, Ford is instituting a number of processes and methods used in this study for its next-generation F-150, which sees production volumes of approximately 400,000 units per year. The study assumed that an existing facility would be updated rather than build a new plant. This is typical automotive practice.

The full manufacturing report is included in Appendix A in Sections 7.1 and 7.1.1.

4.5.6.1 Assembly

Vehicle assembly is broken up into 44 different stations across three different manufacturing areas – a sub-assembly area, underbody line, and framing line. In total, there are 19 different sub-assembly stations, 14 underbody stations, and 11 framing line assembly stations. Table 4.5.6.1.a below lists all of the assembly stations, their individual functions, and the parts involved. A number of idle stations are included to allow for additional production capacity without major retooling.

Table 4.5.6.1.a: Assembly stations, functions, and parts

| Station Name | Assembly Function | Parts Involved |
|--------------|--|---|
| SA05 | Front and rear bumper assembly | Front and rear bumper brackets, mounting plates, beam |
| SA10 | Front frame rail assemblies | Frame rail mounting plates, rails, brackets, transitions, rocker extrusions |
| SA15 | L, R pillar sub-assemblies | A-pillar upper and lower, inner reinforcements; B-pillar upper and lower, inner and outers; roof rail, C-pillar striker reinforcement |
| SA20 | Rear end assembly | L, R shock towers and reinforcements |
| SA25 | X-member sub-assemblies | X-member extrusions, brackets, and reinforcements |
| SA30 | Complete floor X-member assembly | X-member sub-assemblies, crossbraces, reinforcements |
| SA35 | Rear end panel and compartment X-member assembly | Rear inner and outer panels, X-member extrusion and brackets |
| SA40 | Side rail assemblies | Rail and rocker extrusions, brackets, transitions, |

| | | |
|---------|---|---|
| SA45 | L, R rear wheelhouse assemblies | D-pillar inners, quarter panel inners, liftgate reinforcements, wheelhouse inners |
| SA50 | Dash sub-assembly | Dash panel, reinforcements |
| SA55 | Dash assembly | Dash sub-assembly, dash reinforcement, cowl panel support |
| SA60 | Rear seat assembly | Rear seat risers, floor reinforcements, floor panel |
| SA65 | L, R front wheelhouse assemblies | Front wheelhouse panels, shotguns, shock towers |
| SA70-10 | L, R roof, B-pillar bodyside inner assemblies | Front and rear roof side inners, upper and lower B-pillar inners |
| SA70-20 | L, R A-pillar outer assemblies | L, R A-pillar upper and lower outers, shotgun outers |
| SA70-30 | L, R C-pillar bodyside inner assemblies | L, R roof side rail sub-assembly, C-pillar outer upper |
| SA75 | L, R A-pillar inner sub-assemblies | L, R A-pillar upper and lower inners, A-pillar sub-assemblies |
| SA80 | L, R bodyside outer assembly | L, R rear quarter panel, tail lamp closeout, bodyside outer, bodyside outer frame rail, flange |
| SA85 | L, R inner B-Pillar assembly | L, R B-pillar sub-assembly, upper and lower inner reinforcements |
| UB100 | Initial underbody assembly | Floor crossmember, rear end, rear end panel, side rail assemblies |
| UB110 | Initial underbody assembly | Floor crossmember, rear end, rear end panel, side rail assemblies |
| UB120 | Rear wheelhouse and dash buildup | Previous underbody build, dash assembly, dash transmission reinforcements, rear wheelhouse assemblies |
| UB130 | Idle | |
| UB140 | Weld respotting | Previous underbody build |
| UB150 | Rear seat and A-pillar buildup | Previous underbody build, rear seat assembly, A-pillar assemblies |
| UB160 | Idle | |
| UB170 | Front wheelhouse buildup | Previous underbody build, front wheelhouse assemblies |
| UB180 | Central flooring | Previous underbody build, center floor panels |
| UB190 | Rear wheelhouse lining and rear rear flooring | Previous underbody build, rear wheelhouse outers, rear floor panel |
| UB200 | Weld respotting | Previous underbody build |
| UB210 | Stud application | Previous underbody build |
| UB220 | Camera inspection | Previous underbody build |
| UB230 | Elevator to framing | Previous underbody build |
| FR100 | Idle | |
| FR110 | Bodyside outer buildup | Underbody build, L,R bodyside inner assemblies |
| FR120 | Weld respotting | Previous framing build |
| FR130 | Stud application | Previous framing build |
| FR140 | Bodyside inner buildup | Previous framing build, L, R bodyside outer assemblies |
| FR150 | Roof and cowl buildup | Previous framing build, cowl upper panel, roof panel, shotgun closeouts |
| FR160 | Weld respotting | Previous framing build |
| FR170 | Camera inspection | Previous framing build |
| FR180 | Bumper buildup | Previous framing build, front end module, front and rear bumper assemblies |
| FR190 | Surface finishing/reworking | Previous framing build |
| FR200 | Idle, electric motorized system | |

Five different conveyors are needed to transport the BIWs around the assembly plant. One conveyor system is used for the sub-assembly area where the parts are loaded onto it by humans or robots. The sub-assembly area is divided into sections so the parts need to be moved between stations. A second conveyor is needed for the underbody line, which is continuous so parts only need to be loaded once. The third conveyor is used for cross-plant transport between the underbody and framing lines. The underbodies are loaded onto skids, which are then transported across the plant onto the framing line conveyor on the skid. Once the BIWs are complete, the skids are returned to the cross transport conveyor.

The total manufacturing cycle time is 191 seconds after a 15-percent inefficiency factor is considered as shown in Table 4.5.6.1.b. These inefficiencies stem from the equipment (five percent), downtime due to organizational problems (five percent), and system downtime (five percent).

Table 4.5.6.1.b: Cycle time calculations

| | Item | Value | Formula |
|---|----------------------------------|------------|--|
| A | Vehicles/year | 60,000 | |
| B | Working days/year (365-104-11) | 250 | |
| C | Vehicles/day | 240 | A/B |
| D | Shifts | 2 | |
| E | Hours/shifts | 8 | |
| F | Break/shift | 0.5 | |
| G | Uptime/day (seconds/working day) | 54,000 | 7.5 hrs/shift *2 shifts/day *3600 s/hr |
| H | Gross cycle time (seconds) | 225 | G/C |
| I | Inefficiency factor | 15% | |
| J | Net Cycle Time | 191 | H*(1-I) |

4.5.6.2 Labor

The Phase 2 HD vehicle plant will require a total of 47 workers per shift. Of these 47 workers, 24 will be directly employed by the plant to operate the assembly line. The remaining 23 will be indirect and consist of 12 logistics workers (material handlers), 10 maintenance workers, and one coordinate measuring machine operator. Table 4.5.6.2.a below shows the estimated labor costs for the plant (flat year-over-year wages).

Table 4.5.6.2.a: Phase 2 HD BIW estimated labor costs

| Assembly Workers | |
|-----------------------------|--------------------|
| Number | 24 |
| Wage | \$22 |
| Cost per shift | \$4,224 |
| Benefits (40% of wages) | \$1,690 |
| Total cost per shift | \$5,914 |
| Annual cost | \$2,956,800 |

| Maintenance Workers | |
|-----------------------------------|--------------------|
| Number | 11 |
| Wage | \$35 |
| Cost per shift | \$3,080 |
| Benefits (40% of wages) | \$1,232 |
| Total cost per shift | \$4,312 |
| Annual cost | \$2,156,000 |
| Logistics Workers | |
| Number | 12 |
| Wage | \$18 |
| Cost per shift | \$1,728 |
| Benefits (60% of wages) | \$1,037 |
| Total cost per shift | \$2,765 |
| Annual cost | \$1,382,400 |
| Total labor cost per shift | \$12,990 |
| Annual labor cost | \$6,495,200 |
| Labor cost per vehicle | \$108 |

Table 4.5.6.2.b below shows the estimated cost increase per vehicle if the workers receive 3-percent annual raises. By the eighth year (the last year used in the financial analysis), this adds a total of \$17.30 to the cost of each vehicle.

Table 4.5.6.2.b: Phase 2 HD BIW estimated labor cost increases with 3% annual raises

Error! Not a valid link.

These wages are in line with current industry trends towards lower labor costs, with GM targeting a 40-percent reduction in labor costs by 2020 (<http://www.gminsidenews.com/forums/f12/how-small-car-helping-rewrite-labor-costs-u-s-plant-104321/>). VW is already approaching these labor costs in the U.S. at its assembly plant in Chattanooga, Tennessee.

4.5.6.3 Investment and Manufacturing Costs

Constructing a new plant to tool and manufacture the Phase 2 HD BIW is considerably less expensive than building a new plant partially due to the materials and manufacturing techniques used. Low-volume tooling was used due to the Toyota Venza volume of 60,000 units per year. Table 4.5.6.3.a below highlights the costs for the tooling necessary to produce the BIW, which is approximately \$28.1 million compared to the \$70 million estimated by Intellicosting for the Toyota Venza (low volume) tooling.

Table 4.5.6.3.a: Phase 2 HD BIW tooling cost

| Part Number | Part Name | Process | Tool Type | Tool Cost | Tool Count | Inspection Cost | Fixture Count |
|------------------|-----------|---------|-----------|-----------|------------|-----------------|---------------|
| Front End | | | | | | | |

| | | | | | | | |
|--------------------------------|--|----------|--|-----------|---|----------|---|
| 7305-2400-001 | Small crossmember reinforcement | Stamping | Complete progressive die | \$104,559 | 1 | \$1,500 | 1 |
| 7305-2400-002 | Large crossmember reinforcement | Stamping | Complete progressive die | \$114,797 | 1 | \$1,700 | 1 |
| Bodyside Outer Assembly | | | | | | | |
| 7306-2300-185 | Left, outer bodyside panel | Stamping | Transfer dies | | | \$77,900 | 1 |
| | | | Rough blank (through) | \$78,788 | 1 | | |
| | | | Draw (toggle) | \$221,338 | 1 | | |
| | | | Trim and developed trim | \$179,543 | 1 | | |
| | | | Trim and developed trim | \$170,360 | 1 | | |
| | | | Finish form, flange, and restrike | \$221,641 | 1 | | |
| | | | Cam finish form, finish trim, flange, and restrike | \$323,575 | 1 | | |
| | | | End of arm tooling | \$20,000 | | | |
| 7306-2300-186 | Right, outer bodyside panel | Stamping | Transfer dies | | | \$77,900 | 1 |
| | | | Rough blank (through) | \$78,788 | 1 | | |
| | | | Draw (toggle) | \$221,338 | 1 | | |
| | | | Trim and developed trim | \$179,543 | 1 | | |
| | | | Trim and developed trim | \$170,360 | 1 | | |
| | | | Finish form, flange, and restrike | \$221,641 | 1 | | |
| | | | Cam finish form, finish trim, flange, and restrike | \$323,575 | 1 | | |
| | | | End of arm tooling | \$20,000 | | | |
| 7306-2300-187 | Lower, left rear quarter closeout panel | Stamping | Line dies on common shoe (hand transfer) | | | \$11,500 | 1 |
| 7306-2300-188 | Lower, right rear quarter closeout panel | | Form (double attached) | \$48,094 | 1 | \$11,500 | 1 |
| | | | Trim and developed trim | \$54,449 | 1 | | |
| | | | Finish form and flange (double pad) | \$64,348 | 1 | | |
| | | | Finish trim and separate | \$42,106 | 1 | | |
| | | | Flange and restrike (double pad and double unattached) | \$62,632 | 1 | | |
| | | | Common Shoe | \$19,984 | | | |
| 7306-2300-189 | Left flange to body | Stamping | Complete progressive die (2 out, 1 left and 1 right) | \$195,951 | 1 | \$18,000 | 1 |
| 7306-2300-190 | Right flange to body | | | | | \$18,000 | 1 |
| 7306-2300-191 | Left tail lamp closeout panel | Stamping | Complete progressive die (2 out, 1 left and 1 right) | \$80,703 | 1 | | |
| 7306-2300-192 | Right tail lamp closeout panel | | | | | | |
| 7306-2300-XXX | Left, upper rear closeout panel | Stamping | Progressive blank die (2 out, 1 left and 1 right) | \$92,887 | 1 | \$3,500 | 1 |
| 7306-2300-XXX | Right, upper rear closeout panel | | Form and flange (double pad) | \$43,265 | 1 | \$3,500 | 1 |
| | | | Restrike and cam flange | \$36,986 | 1 | | |
| | | | Common shoe | \$10,378 | | | |
| Roof | | | | | | | |
| 7306-2200-109 | Roof panel | Stamping | Lines with robotic transfer | | | \$77,500 | 1 |
| | | | Draw | \$173,807 | 1 | | |

| | | | | | | | |
|--------------------------|-----------------------------------|----------|--|-----------|---|----------|---|
| | | | Trim and developed trim | \$198,072 | 1 | | |
| | | | Finish form, flange, and restrike | \$208,060 | 1 | | |
| | | | End of arm tooling | \$9,000 | | | |
| 7306-2100-101 | Front header (bow 1) | Stamping | Coil fed transfer die | | | \$14,800 | 1 |
| | | | Cutoff and draw | \$57,820 | 1 | | |
| | | | Trim | \$64,302 | 1 | | |
| | | | Finish form and flange | \$65,305 | 1 | | |
| | | | Finish trim | \$60,365 | 1 | | |
| | | | Restrike | \$64,736 | 1 | | |
| | | | Master shoes | \$47,361 | | | |
| | | | End of arm tooling | \$12,500 | | | |
| 7306-2100-103 | Center header (bow 2) | Stamping | Complete progressive die | \$127,928 | 1 | \$6,500 | 1 |
| 7307-2100-104 | Rear header (bow 3) | Stamping | Transfer dies | | | \$27,500 | 1 |
| | | | Draw | \$52,969 | 1 | | |
| | | | Form | \$51,038 | 1 | | |
| | | | Form | \$51,038 | 1 | | |
| | | | Trim and pierce | \$70,184 | 1 | | |
| | | | Finish form, flange, and restrike | \$55,997 | 1 | | |
| | | | Common shoes | \$40,773 | | | |
| | | | End of arm tooling | \$15,000 | | | |
| 7306-2000-215 | Left, rear roof side rail inner | Stamping | Transfer dies | | | \$19,400 | 1 |
| 7306-2000-216 | Right, rear roof side rail inner | | Draw (double attached) | \$77,254 | 1 | \$19,400 | 1 |
| | | | Trim, developed trim, and partial separate | \$101,937 | 1 | | |
| | | | Finish form, flange, and restrike | \$115,242 | 1 | | |
| | | | Finish trim and separate | \$70,324 | 1 | | |
| | | | Common shoes | \$59,758 | | | |
| | | | End of arm tooling | \$12,800 | | | |
| 7306-2000-171 | Left, front roof side rail inner | Stamping | Transfer dies | | | \$20,500 | 1 |
| 7306-2000-172 | Right, front roof side rail inner | | Rough developed blank | \$75,651 | 1 | \$20,500 | 1 |
| | | | Form (double attached) | \$86,347 | 1 | | |
| | | | Trim, developed trim, and partial separate | \$114,175 | 1 | | |
| | | | Finish form, flange, and restrike | \$129,433 | 1 | | |
| | | | Finish trim and separate | \$97,949 | 1 | | |
| | | | Master shoes | \$40,671 | | | |
| | | | End of arm tooling | \$16,000 | | | |
| 7305-1900-159 | Left shotgun closeout | Stamping | Complete progressive die | \$37,190 | 1 | \$600 | 1 |
| 7305-1900-160 | Right shotgun closeout | | | | | \$600 | 1 |
| D-pillar Assembly | | | | | | | |
| 7307-2110-179 | Left liftgate reinforcement | Stamping | Line dies on common shoe (hand transfer) | | | \$6,800 | 1 |
| 7307-2120-180 | Right liftgate | | Form (double attached) | \$52,567 | 1 | \$6,800 | 1 |

| | | | | | | | | |
|--------------------------|--|----------|--|-----------|---|----------|--|---|
| | reinforcement | | | | | | | |
| | | | Trim and developed trim | \$64,216 | 1 | | | |
| | | | Trim and developed trim | \$63,082 | 1 | | | |
| | | | Finish form and flange (double pad) | \$73,414 | 1 | | | |
| | | | Restrike and separate | \$69,770 | 1 | | | |
| | | | Common shoe | \$27,234 | | | | |
| 7307-2110-105 | Left D-pillar inner | Stamping | Transfer dies | | | \$18,900 | | 1 |
| 7307-2120-106 | Right D-pillar inner | | Rough blank | \$56,788 | 1 | \$18,900 | | 1 |
| | | | Draw (double attached) | \$81,398 | 1 | | | |
| | | | Redraw | \$82,579 | 1 | | | |
| | | | Trim and developed trim | \$91,616 | 1 | | | |
| | | | Trim, developed trim, and separate | \$85,274 | 1 | | | |
| | | | Finish form and restrike (double unattached) | \$93,307 | 1 | | | |
| | | | Master shoes | \$62,202 | | | | |
| | | | End of arm tooling | | | | | |
| 7307-2110-177 | Left quarter panel inner | Stamping | Transfer dies | | | \$6,200 | | |
| 7307-2120-178 | Right quarter panel inner | | Draw (double attached) | \$72,014 | 1 | \$6,200 | | |
| | | | Trim and developed trim | \$73,368 | 1 | | | |
| | | | Trim and developed trim | \$69,069 | 1 | | | |
| | | | Finish form, flange, and restrike (double pad) | \$75,455 | 1 | | | |
| | | | Cam trim, trim, and separate | \$81,170 | 1 | | | |
| | | | Master shoes | \$49,982 | | | | |
| | | | End of arm tooling | \$10,500 | | | | |
| A-pillar Assembly | | | | | | | | |
| 7305-1930-169 | Left shotgun outer panel | Stamping | Transfer dies | | | \$22,500 | | 1 |
| 7305-1940-170 | Right shotgun outer panel | | Rough blank die (2 out, 1 left and 1 right) | \$127,161 | 1 | \$22,500 | | 1 |
| | | | Form | \$77,416 | 1 | | | |
| | | | Finish form and flange | \$112,533 | 1 | | | |
| | | | Trim | \$124,796 | 1 | | | |
| | | | Flange and restrike | \$74,492 | 1 | | | |
| | | | Master shoes | \$45,023 | | | | |
| | | | End of arm tooling | \$14,400 | | | | |
| 7305-1930-187 | Left, lower A-pillar outer | Stamping | Line dies with robotic transfer | | | \$16,000 | | 1 |
| 7305-1940-188 | Right, lower A-pillar outer | | Blank (flip/flop left/right) | \$102,114 | 1 | \$16,000 | | 1 |
| | | | Form (double unattached) | \$115,352 | 1 | | | |
| | | | Trim and developed trim | \$105,079 | 1 | | | |
| | | | Trim and developed trim | \$118,609 | 1 | | | |
| | | | Finish form and flange | \$80,009 | 1 | | | |
| | | | Restrike | \$131,158 | 1 | | | |
| | | | End of arm tooling | \$7,500 | | | | |
| 7305-1930-171 | Left, A-pillar, upper hinge reinforcement | Stamping | Complete progressive die | \$13,902 | 1 | \$350 | | 1 |
| 7305-1940-184 | Right, A-pillar, upper hinge reinforcement | | | | | \$350 | | 1 |

| | | | | | | | |
|-------------------------------|--|----------|--|-----------|---|----------|---|
| 7305-1930-173 | Left, A-pillar, lower hinge reinforcement | Stamping | Complete progressive die | \$13,596 | 1 | \$350 | 1 |
| 7305-1940-186 | Right, A-pillar, lower hinge reinforcement | | | | | \$350 | 1 |
| 7305-1500-227 | Left, lower, A-pillar reinforcement | Stamping | Complete progressive die | \$54,462 | 1 | \$900 | 1 |
| 7305-1500-228 | Right, lower, A-pillar reinforcement | | | | | | |
| 7305-1400-153 | Left, lower A-pillar inner | Stamping | Line dies on common shoe (hand transfer) | | | \$4,400 | 1 |
| 7305-1400-154 | Right, lower A-pillar inner | | Draw | \$55,162 | 1 | \$4,400 | 1 |
| | | | Restrike | \$58,268 | 1 | | |
| | | | Trim and partial separate | \$51,334 | 1 | | |
| | | | Cam trim, trim, and separate | \$66,797 | 1 | | |
| | | | Common shoe | \$18,367 | | | |
| 7305-1300-155 | Left, upper A-pillar inner | Stamping | Line dies on common shoe (hand transfer) | | | \$28,000 | 1 |
| 7305-1300-156 | Right, upper A-pillar inner | | Progressive developed blank (double attached) | \$139,832 | 1 | \$28,000 | 1 |
| | | | Form and flange | \$67,679 | 1 | | |
| | | | Flange and restrike (double pad) | \$68,126 | 1 | | |
| | | | Extrude and separate | \$55,145 | 1 | | |
| | | | Common shoe | \$16,962 | | | |
| Door Aperture Assembly | | | | | | | |
| 7306-1910-189 | Left, A-pillar outer upper | Stamping | Transfer dies | | | \$19,500 | 1 |
| 7306-1920-190 | Right, A-pillar outer upper | | Draw (double attached) | \$105,668 | 1 | \$19,500 | 1 |
| | | | Trim, developed trim, and partial separate | \$128,641 | 1 | | |
| | | | Finish form, flange, and restrike | \$135,645 | 1 | | |
| | | | Finish trim and separate | \$97,420 | 1 | | |
| | | | Master shoes | \$40,392 | | | |
| | | | End of arm tooling | \$12,000 | | | |
| 7306-1910-191 | Left, roof side rail outer | Stamping | Transfer dies | | | \$16,000 | 1 |
| 7306-1920-192 | Right, roof side rail outer | | Draw (double attached) | \$79,668 | 1 | \$16,000 | 1 |
| | | | Trim, developed trim, and partial separate | \$105,077 | 1 | | |
| | | | Finish form, flange, and restrike | \$105,767 | 1 | | |
| | | | Finish trim and separate | \$89,247 | 1 | | |
| | | | Master shoes | \$41,042 | | | |
| | | | End of arm tooling | \$16,000 | | | |
| 7306-1910-193 | Left, C-pillar striker reinforcement | Stamping | Complete progressive die (2 out, 1 left and 1 right) | \$34,332 | 1 | \$650 | 1 |
| 7306-1920-194 | Right, C-pillar striker reinforcement | | | | | \$650 | 1 |
| 7306-1910-195 | Left C-pillar outer | Stamping | Line dies with robotic transfer | | | \$39,000 | 1 |

| | | | | | | | |
|---------------|---|----------|--|-----------|---|----------|---|
| 7306-1920-196 | Right C-pillar outer | | Rough blank (double attached) | \$93,644 | 1 | \$39,000 | 1 |
| | | | Draw (double attached) | \$151,092 | 1 | | |
| | | | Trim and developed trim | \$167,760 | 1 | | |
| | | | Trim and developed trim | \$165,870 | 1 | | |
| | | | Finish form, flange, and restrike (double pad) | \$205,755 | 1 | | |
| | | | Separate and cam set flanges | \$144,189 | 1 | | |
| | | | End of arm tooling | \$15,000 | | | |
| 7306-1913-001 | Left, lower B-pillar outer | Stamping | Line dies with robotic transfer | | | \$32,500 | 1 |
| 7306-1924-002 | Right, lower B-pillar outer | | Rough blank (flip/flop left/right) | \$101,111 | 1 | \$32,500 | 1 |
| | | | Draw (double unattached) | \$149,138 | 1 | | |
| | | | Redraw | \$152,991 | 1 | | |
| | | | Trim and pierce | \$174,868 | 1 | | |
| | | | Trim and pierce | \$167,712 | 1 | | |
| | | | Finish form, flange, and restrike | \$179,334 | 1 | | |
| | | | End of arm tooling | \$15,000 | | | |
| 7306-1913-003 | Left, upper B-pillar outer | Stamping | Transfer dies | | | \$5,900 | 1 |
| 7306-1924-004 | Right, upper B-pillar outer | | Draw (double attached) | \$46,469 | 1 | \$5,900 | |
| | | | Rough trim and developed trim | \$50,711 | 1 | | |
| | | | Rough trim and developed trim | \$48,596 | 1 | | |
| | | | Finish form, flange, and restrike | \$55,535 | 1 | | |
| | | | Cam trim, trim, and separate | \$75,051 | 1 | | |
| | | | Master shoes | \$29,621 | | | |
| | | | End of arm tooling | \$12,000 | | | |
| 7306-1913-005 | Left, upper, B-pillar inner reinforcement | Stamping | Complete progressive die (2 out, 1 left and 1 right) | \$72,875 | 1 | \$1,250 | 1 |
| 7306-1924-006 | Right, upper, B-pillar inner reinforcement | | | | | \$1,250 | 1 |
| 7306-1913-007 | Left, middle, B-pillar inner reinforcement | Stamping | Complete progressive die (2 out, 1 left and 1 right) | \$32,508 | 1 | \$600 | 1 |
| 7306-1924-008 | Right, middle, B-pillar inner reinforcement | | | | | \$600 | 1 |
| 7306-1913-009 | Left, lower, B-pillar inner reinforcement | Stamping | Complete progressive die (2 out, 1 left and 1 right) | \$81,191 | 1 | \$950 | 1 |
| 7306-1924-010 | Right, lower, B-pillar inner reinforcement | | | | | \$950 | 1 |
| 7306-1915-011 | Left, lower B-pillar inner | Stamping | Line dies with robotic transfer | | | \$15,500 | 1 |
| 7306-1926-012 | Right, lower B-pillar inner | | Rough blank (flip/flop left/right) | \$891,730 | 1 | \$15,500 | 1 |
| | | | Draw (double unattached) | \$85,677 | 1 | | |
| | | | Trim and pierce | \$119,560 | 1 | | |
| | | | Trim and pierce | \$119,560 | 1 | | |
| | | | Finish form, extrude, and restrike (double pad) | \$99,233 | 1 | | |
| | | | End of arm tooling | \$16,000 | | | |

| | | | | | | | |
|--------------------------------|--|----------------|--|-----------|---|----------|---|
| 7306-1915-001 | Left/right B-pillar beltline reinforcement | Stamping | Complete progressive die | \$16,934 | 1 | \$500 | 1 |
| 7306-1915-013 | Left, upper B-pillar inner | Stamping | Complete progressive die (2 out, 1 left and 1 right) | \$97,237 | 1 | \$3,300 | 1 |
| 7306-1926-014 | Right, upper B-pillar inner | | | | | \$3,300 | 1 |
| Dash and Cowl Structure | | | | | | | |
| 7305-1800-145 | Upper cowl panel | Cast magnesium | Casting mold | \$141,000 | 1 | \$23,400 | 1 |
| | | | Trim die | \$60,561 | 1 | | |
| 7305-1700-147 | Cowl panel support | Stamping | Transfer dies | | | \$18,500 | 1 |
| | | | Draw | \$74,731 | 1 | | |
| | | | Trim and developed trim | \$92,078 | 1 | | |
| | | | Trim, developed trim, and cam trim | \$112,671 | 1 | | |
| | | | Finish form, flange, and restrike | \$95,243 | 1 | | |
| | | | Common shoes | \$20,631 | | | |
| | | | End of arm tooling | \$10,000 | | | |
| 7305-1600-149 | Dash panel reinforcement | Cast magnesium | Casting mold | \$216,000 | 1 | \$31,600 | 1 |
| | | | Trim die | \$132,513 | 1 | | |
| 7307-1600-183 | Left, rear wheelhouse outer panel | Cast magnesium | Casting mold | \$250,000 | 1 | \$43,800 | 1 |
| | | | Trim die | \$142,164 | 1 | | |
| 7307-1600-184 | Right, rear wheelhouse outer panel | Cast magnesium | Casting mold | \$240,000 | 1 | \$41,400 | 1 |
| | | | Trim die | \$138,966 | 1 | | |
| 7307-1600-213 | Left, rear closeout panel | Stamping | Complete progressive die (2 out, 1 left and 1 right) | \$192,307 | 1 | \$9,600 | 1 |
| 7307-1600-214 | Right, rear closeout panel | | | | | \$9,600 | 1 |
| 7305-1500-157 | Left, shotgun panel inner | Stamping | Transfer dies | | | \$28,500 | 1 |
| 7305-1500-158 | Right, shotgun panel inner | | Rough blank die (2 out, 1 left and 1 right) | \$133,440 | 1 | \$28,500 | 1 |
| | | | Form | \$87,170 | 1 | | |
| | | | Finish form and flange | \$117,563 | 1 | | |
| | | | Trim | \$132,094 | 1 | | |
| | | | Flange and restrike | \$77,572 | 1 | | |
| | | | Master shoes | \$48,895 | | | |
| | | | End of arm tooling | \$14,400 | | | |
| 7305-1500-197 | Left, upper A-pillar reinforcement | Stamping | Complete progressive die (2 out, 1 left and 1 right) | \$137,042 | 1 | \$2,250 | 1 |
| 7305-1500-198 | Right, upper A-pillar reinforcement | | | | | \$2,250 | 1 |
| 7305-1530-221 | Left, dash transmission reinforcement | Stamping | Line dies (hand transfer) | | | \$21,500 | 1 |

| | | | | | | | |
|-----------------|--|----------------|--|-----------|---|----------|---|
| 7305-1530-222 | Right, dash transmission reinforcement | | Draw (double unattached) | \$93,191 | 1 | \$21,500 | 1 |
| | | | Second draw | \$96,656 | 1 | | |
| | | | Rough trim and developed trim | \$88,494 | 1 | | |
| | | | Developed trim and cam developed trim | \$87,500 | 1 | | |
| | | | Form and flange | \$88,188 | 1 | | |
| | | | Form and flange | \$82,126 | 1 | | |
| | | | Finish trim, pierce, and cam pierce | \$93,594 | 1 | | |
| | | | Cam flange and restrike | \$81,087 | 1 | | |
| 7305-1530-223 | Left, dash transmission insert | Stamping | Complete progressive die (2 out, 1 left and 1 right) | \$62,424 | 1 | \$950 | 1 |
| 7305-1520-224 | Right, dash transmission insert | | | | | \$950 | 1 |
| 7305-1400-143 | Upper dash panel | Cast magnesium | Casting mold | \$206,000 | 1 | \$52,700 | 1 |
| | | | Trim die | \$129,768 | 1 | | |
| 7305-1400-144 | Left lower dash panel | Cast magnesium | Casting mold | \$317,000 | 1 | \$36,000 | 1 |
| 7305-1400-145 | Right lower dash panel | | Trim die | \$230,467 | 1 | \$36,000 | 1 |
| Rear End | | | | | | | |
| 7307-1510-111 | Rear end outer panel | Stamping | Line dies with robotic transfer | | | \$43,500 | 1 |
| | | | Draw | \$74,912 | 1 | | |
| | | | Trim and developed trim | \$81,087 | 1 | | |
| | | | Trim and developed trim | \$81,016 | 1 | | |
| | | | Finish form and flange | \$83,914 | 1 | | |
| | | | Finish form, flange, and restrike | \$85,112 | 1 | | |
| | | | Finish trim and pierce | \$82,672 | 1 | | |
| | | | End of arm tooling | \$18,000 | | | |
| 7307-1510-117 | Rear end inner panel | Stamping | Line dies with robotic transfer | | | \$39,500 | 1 |
| | | | Draw | \$84,640 | 1 | | |
| | | | Rough trim and developed trim | \$92,852 | 1 | | |
| | | | Redraw | \$80,037 | 1 | | |
| | | | Developed trim | \$89,698 | 1 | | |
| | | | Developed trim and pierce | \$91,062 | 1 | | |
| | | | Finish form, flange, and restrike (double pad) | \$95,070 | 1 | | |
| | | | End of arm tooling | \$18,000 | | | |
| 7307-1400-119 | Rear compartment crossmember | Extrude | Extrusion tooling | \$49,416 | 2 | \$12,000 | 1 |
| | | | Trim jig | \$3,115 | 1 | | |
| 7307-1410-120 | Extrusion hangar bracket | Extrude | Extrusion tooling | \$49,986 | 2 | \$1,250 | 1 |
| | | | Trim jig | \$2,041 | 1 | | |
| 7307-1400-163 | Left, rear wheelhouse inner panel | Stamping | Line dies with robotic transfer | | | \$38,500 | 1 |

| | | | | | | | |
|-------------------------|---|----------------|--|-----------|---|----------|---|
| 7307-1400-164 | Right, rear wheelhouse inner panel | | Draw (double attached) | \$146,206 | 1 | \$38,500 | 1 |
| | | | Trim and developed trim | \$163,555 | 1 | | |
| | | | Trim and developed trim | \$163,555 | 1 | | |
| | | | Finish form, flange, and restrike (double pad) | \$238,243 | 1 | | |
| | | | Finish trim and separate | \$117,380 | 1 | | |
| | | | End of arm tooling | \$15,000 | | | |
| 7307-1500-167 | Left, rear shock tower reinforcement | Stamping | Line dies on common shoes (hand transfer) | | | \$3,100 | 1 |
| 7307-1500-168 | Right, rear shock tower reinforcement | | Draw (double attached) | \$38,164 | 1 | \$3,100 | 1 |
| | | | Trim and rough trim | \$44,667 | 1 | | |
| | | | Developed trim | \$39,082 | 1 | | |
| | | | Cam developed trim | \$56,093 | 1 | | |
| | | | Finish form and flange | \$42,219 | 1 | | |
| | | | Aerial cam flange | \$64,149 | 1 | | |
| | | | Separate and restrike | \$42,620 | 1 | | |
| | | | Common shoes | \$28,685 | | | |
| 7305-1300-165 | Left, rear shock tower | Die cast | Casting mold | \$126,000 | 1 | \$26,000 | 1 |
| | | | Trim die | \$75,977 | 1 | | |
| 7305-1300-166 | Right, rear shock tower | Die cast | Casting mold | \$132,000 | 1 | \$26,000 | 1 |
| | | | Trim die | \$75,977 | 1 | | |
| Front Wheelhouse | | | | | | | |
| 7305-1310-151 | Left front shock tower | Die cast | Casting mold | \$119,000 | 1 | \$27,500 | 1 |
| | | | Trim die | \$79,812 | 1 | | |
| 7305-1320-152 | Right front shock tower | Die cast | Casting mold | \$125,000 | 1 | \$27,500 | 1 |
| | | | Trim die | \$79,812 | 1 | | |
| 7305-1310-161 | Left front wheelhouse panel | Cast magnesium | Casting mold | \$141,000 | 1 | \$21,900 | 1 |
| | | | Trim die | \$80,095 | 1 | | |
| 7305-1320-162 | Right front wheelhouse panel | Cast magnesium | Casting mold | \$148,000 | 1 | \$21,900 | 1 |
| | | | Trim die | \$80,095 | 1 | | |
| Rear Seat | | | | | | | |
| 7306-1200-113 | Rear seat floor panel | Stamping | Line dies with robotic transfer | | | \$33,800 | 1 |
| | | | Draw | \$93,535 | 1 | | |
| | | | Trim | \$114,717 | 1 | | |
| | | | Finish form and restrike | \$77,468 | 1 | | |
| | | | End of arm tooling | \$9,000 | | | |
| 7306-1200-111 | Rear seatbelt anchorage plate | Stamping | Complete progressive die | \$26,206 | 1 | \$650 | 1 |
| 7307-1200-217 | Left, rear, outer frame rail transition | Die cast | Casting mold | \$192,000 | 1 | \$28,500 | 1 |
| | | | Trim die | \$116,537 | 1 | | |

| | | | | | | | |
|--------------------|---|----------|------------------------------------|-----------|---|----------|---|
| 7307-1200-218 | Right, rear, outer frame rail transition | Die cast | Casting mold | \$199,000 | 1 | \$28,500 | 1 |
| | | | Trim die | \$116,537 | 1 | | |
| 7306-1110-101 | Center rear seat riser | Stamping | Complete progressive die | \$216,500 | 1 | \$29,800 | 1 |
| 7306-1110-103 | Left, rear seat floor reinforcement | Stamping | Complete progressive die | \$58,424 | 1 | \$2,600 | 1 |
| 7306-1000-175 | Left rear seat riser | Stamping | Line dies with robotic transfer | | | \$21,500 | 1 |
| 7306-1000-176 | Right rear seat riser | | Rough blank (flip/flop left/right) | \$53,598 | 1 | \$21,500 | 1 |
| | | | Form (double unattached) | \$61,333 | 1 | | |
| | | | Trim and developed trim | \$80,561 | 1 | | |
| | | | Trim and developed trim | \$80,561 | 1 | | |
| | | | Finish form and flange | \$97,654 | 1 | | |
| | | | Restrike | \$91,442 | 1 | | |
| | | | End of arm tooling | \$16,000 | | | |
| Frame Rails | | | | | | | |
| 7307-1000-139 | Right/left rear frame rail | Extrude | Extrusion tooling | \$46,850 | 2 | \$8,600 | 1 |
| | | | Trim jig | \$2,918 | 1 | | |
| 7307-1000-138 | Right/left rear frame rail mounting plate | Stamping | Complete progressive die | \$36,086 | 1 | \$650 | 1 |
| 7307-1020-135 | Left front frame rail | Extrude | Extrusion tooling | \$46,850 | 2 | \$6,500 | 1 |
| 7307-1020-136 | Right front frame rail | | Trim jig | \$2,506 | 1 | | |
| 7307-1020-223 | Left frame rail mounting plate | Stamping | Complete progressive die | \$43,803 | 1 | \$850 | 1 |
| 7307-1020-224 | Right frame rail mounting plate | | | | | | |
| 7307-1011-001 | Left/right front rail mounting | Stamping | Complete progressive die | \$43,627 | 1 | \$1,450 | 1 |
| 7307-1011-003 | Left/right front rail mounting cover | Stamping | Complete progressive die (2 out) | \$59,154 | 1 | \$1,250 | 1 |
| 7305-0900-137 | Left, front, inner frame rail transition | Die cast | Casting mold | \$184,000 | 1 | \$25,500 | 1 |
| | | | Trim die | \$113,428 | 1 | | |
| 7305-0900-138 | Right, front, inner frame rail transition | Die cast | Casting mold | \$190,000 | 1 | \$25,500 | 1 |
| | | | Trim die | \$113,428 | 1 | | |
| 7307-0900-141 | Left, rear, inner frame rail transition | Die cast | Casting mold | \$195,000 | 1 | \$28,500 | 1 |
| | | | Trim die | \$117,447 | 1 | | |
| 7307-0900-142 | Right, rear, inner frame rail transition | Die cast | Casting mold | \$201,000 | 1 | \$28,500 | 1 |
| | | | Trim die | \$117,447 | 1 | | |
| 7306-0810-123 | Left rocker sill extrusion | Extrude | Extrusion tooling | \$51,412 | 2 | \$31,750 | 1 |

| | | | | | | | |
|---|---|----------|--------------------------|-------------------------|------------|------------------------|------------|
| 7306-0810-124 | Right rocker sill extrusion | | Trim jig | \$3,655 | 1 | | |
| 7305-1200-209 | Left front frame rail outer transition | Die cast | Casting mold | \$179,000 | 1 | \$25,500 | 1 |
| | | | Trim die | \$111,602 | 1 | | |
| 7305-1200-210 | Right front frame rail outer transition | Die cast | Casting mold | \$185,000 | 1 | \$25,500 | 1 |
| | | | Trim die | \$111,602 | 1 | | |
| Floor | | | | | | | |
| 7306-0830-124 | Left/right, small outer floor extrusion | Extrude | Extrusion tooling | \$53,122 | 2 | \$1,500 | 1 |
| 7306-0840-010 | Left/right, large outer floor extrusion | | Trim jig | \$2,363 | 1 | \$1,600 | 1 |
| 7306-0830-125 | Left/right, small floor crossmember | Extrude | Extrusion tooling | \$46,280 | 2 | \$15,900 | 1 |
| | | | Trim jig | \$3,115 | 1 | | |
| 7306-0830-126 | Left/right, small inner floor extrusion | Extrude | Extrusion tooling | \$53,122 | 2 | \$1,600 | 1 |
| 7306-0840-012 | Left/right, large inner floor extrusion | | Trim jig | \$2,041 | 1 | \$1,750 | 1 |
| 7306-0840-011 | Left/right, large floor crossmember | Extrude | Extrusion tooling | \$47,134 | 2 | \$17,300 | 1 |
| | | | Trim jig | \$3,331 | 1 | | |
| 7306-0850-000 | Left/right, fore/aft floor extrusions | Extrude | Extrusion tooling | \$44,854 | 2 | \$17,600 | 1 |
| | | | Trim jig | \$3,223 | 1 | | |
| 7306-0860-000 | Center tunnel bracket | Stamping | Complete progressive die | \$25,733 | 1 | \$650 | 1 |
| Totals | | | | \$ 26,017,503.00 | 253 | \$ 2,102,900.00 | 121 |
| Annual (amortized over 3 years) | | | | | | \$9,373,468 | |
| Per BIW (amortized over 3 years) | | | | | | \$156 | |
| Annual (amortized over 5 years) | | | | | | \$5,624,081 | |
| Per BIW (amortized over 5 years) | | | | | | \$94 | |

In addition to estimating tooling cost, Intellicosting estimated the total piece cost for the Phase 2 HD BIW at \$1930 – an increase of \$723 compared to the Toyota Venza estimate as shown in Tables 4.5.6.3.b below.

Table 4.5.6.3.b: Toyota Venza and Phase 2 HD BIW piece costs

| Category | Venza | Phase 2 HD |
|----------|----------|------------|
| Material | \$907.94 | \$1,282.05 |

| | | |
|--------------|-------------------|-------------------|
| Variable | \$67.34 | \$157.05 |
| Fixed | \$52.59 | \$160.04 |
| Direct | \$23.04 | \$59.13 |
| Profit | \$83.02 | \$147.22 |
| SG&A | \$52.55 | \$100.04 |
| Freight | \$20.84 | \$25.01 |
| Total | \$1,207.32 | \$1,930.54 |

A summary of the total manufacturing costs per year can be found in Table 4.5.6.3.c below – they are broken down by year as the capital costs are amortized over five and seven years while capital maintenance costs are per annum based on the suggested amortization schedule from EBZ. Year eight represents the full amortization of capital expenditures and is only the annual maintenance cost. Eight years does however, exceed the typical vehicle life cycle. The reason for EBZ’s augmented amortization schedule is that the CMM isn’t dependent on a vehicle lifecycle like the manufacturing equipment is and can simply be reprogrammed for the next vehicle body produced at the plant. The plant must be retooled to produce a different vehicle. A more detailed analysis can be found in section 10.4 of Appendix A. Interest was taken into account here to provide cost parity with the Toyota Venza. This is the only area in which interest was taken into account simply to provide a direct cost comparison. Normally, interest and depreciation would be taken into account in determining model line costs, but only the BIW cost comparison is of interest in this report. A full financial workup – including depreciation, dispersion of funds across vehicle model lines, and varying interest levels available to automakers – is beyond the scope of this study.

Table 4.5.6.3.c: Phase 2 HD BIW manufacturing costs

| Category | Year 1 | Year 2 | Year 3 | Year 4 | Year 5 | Year 6 | Year 7 | Year 8 |
|----------------------|----------------|----------------|----------------|----------------|----------------|----------------|----------------|----------------|
| Capital Costs (mils) | \$11.01 | \$11.01 | \$11.01 | \$11.01 | \$11.01 | \$1.09 | \$1.09 | \$0.74 |
| Labor | \$6.50 | \$6.50 | \$6.50 | \$6.50 | \$6.50 | \$6.50 | \$6.50 | \$6.50 |
| Utilities | \$2.94 | \$2.94 | \$2.94 | \$2.94 | \$2.94 | \$2.94 | \$2.94 | \$2.94 |
| Interest | \$2.52 | \$2.52 | \$2.52 | \$2.52 | \$2.52 | \$2.52 | \$2.52 | \$2.52 |
| Freight | \$1.50 | \$1.50 | \$1.50 | \$1.50 | \$1.50 | \$1.50 | \$1.50 | \$1.50 |
| SG&A (mils) | \$1.43 | \$1.43 | \$1.43 | \$1.43 | \$1.43 | \$0.74 | \$0.74 | \$0.71 |
| Annual Total | \$25.89 | \$25.89 | \$25.89 | \$25.89 | \$25.89 | \$15.28 | \$15.28 | \$14.91 |
| BIW Total | \$432 | \$432 | \$432 | \$432 | \$432 | \$255 | \$255 | \$248 |

Table 4.5.6.3.d below shows the total cost to produce each BIW including manufacturing costs, piece costs, and tooling costs. The costs are broken out by the number of years of tooling amortization and per year due to the amortization schedules.

Table 4.5.6.3.d: BIW cost based on recommended amortization schedule with tooling

| Category | Year 1 | Year 2 | Year 3 | Year 4 | Year 5 | Year 6 | Year 7 | Year 8 |
|----------|--------|--------|--------|--------|--------|--------|--------|--------|
|----------|--------|--------|--------|--------|--------|--------|--------|--------|

| | | | | | | | | |
|---|----------------|----------------|----------------|----------------|----------------|----------------|----------------|----------------|
| Piece cost | \$1,930 | \$1,930 | \$1,930 | \$1,930 | \$1,930 | \$1,930 | \$1,930 | \$1,930 |
| Manufacturing cost | \$432 | \$432 | \$432 | \$432 | \$432 | \$255 | \$255 | \$248 |
| Tooling Costs Amortized Over 3 Years | | | | | | | | |
| Annual tooling cost (mils) | \$9.37 | \$9.37 | \$9.37 | \$0.00 | \$0.00 | \$0.00 | \$0.00 | \$0.00 |
| Tooling cost per BIW | \$156 | \$156 | \$156 | \$0.00 | \$0.00 | \$0.00 | \$0.00 | \$0.00 |
| Total BIW Cost | \$2,517 | \$2,517 | \$2,517 | \$2,357 | \$2,357 | \$2,184 | \$2,184 | \$2,177 |
| Tooling Costs Amortized Over 5 Years | | | | | | | | |
| Annual tooling cost (mils) | \$5.62 | \$5.62 | \$5.62 | \$5.62 | \$5.62 | \$0.00 | \$0.00 | \$0.00 |
| Tooling cost per BIW | \$94 | \$94 | \$94 | \$94 | \$94 | \$0.00 | \$0.00 | \$0.00 |
| Total BIW Cost | \$2,455 | \$2,455 | \$2,455 | \$2,455 | \$2,455 | \$2,184 | \$2,184 | \$2,177 |

In addition to conducting an analysis based on EBZ's recommended amortization schedule, all vehicle assembly costs were amortized over straight three and five year periods. In Table 4.5.6.3.d above, only the tooling costs were amortized over the three and five year periods. These results are shown in Table 4.5.6.3.e below. The net effect was a constant BIW cost over the three and five year periods with small cost increases in both instances – the greatest difference is less than \$500.

Table 4.5.6.3.e: Straight 3- and 5-year amortization schedule

| Category | 3 Year Amortization | 5 Year Amortization |
|-----------------------|---------------------|---------------------|
| Piece cost | \$1,930 | \$1,930 |
| Capital costs per BIW | \$301 | \$186 |
| Labor per BIW | \$108 | \$108 |
| Tooling cost per BIW | \$156 | \$94 |
| Utilities per BIW | \$49 | \$49 |
| Interest per BIW | \$42 | \$42 |
| Freight per BIW | \$25 | \$25 |
| SG&A per BIW | \$24 | \$24 |
| BIW Total | \$2,634 | \$2,457 |

Table 4.5.6.3.f below details the cost breakdown within the actual body structure – underbody, dash panel, front structure, bodysides, etc. The piece cost for each section is shown along with the assembly, tooling, paint, and NVH costs.

Table 4.5.6.3.f: Assembly cost breakdown by body section

| System or Subsystem | Baseline Venza | | Phase 2 | | | | Incremental Cost | |
|----------------------|--------------------|----------------|-------------------|---------------|------------|------------|------------------|------------------------------|
| | Baseline Mass (kg) | Estimated Cost | Phase 2 Mass (kg) | Material Cost | Build Cost | Total Cost | Incremental Cost | Percentage Increase/Decrease |
| Body structure | 382.5 | | 241.8 | | | | | |
| - Underbody & floor | 113.65 | \$170 | 92.7 | \$133 | \$107 | \$274 | \$104 | 61% |
| - Dash panel | 16.97 | \$81 | 11.9 | \$111 | \$27 | \$157 | \$77 | 94% |
| - Front structure | 32.45 | \$124 | 17.1 | \$45 | \$18 | \$71 | -\$53 | -43% |
| - Left bodyside | 79.5 | \$224 | 33.3 | \$339 | \$30 | \$424 | \$200 | 89% |
| - Right bodyside | 79.5 | \$224 | 33.2 | \$338 | \$30 | \$422 | \$198 | 89% |
| - Roof | 27.83 | \$74 | 16.9 | \$85 | \$5 | \$103 | \$29 | 40% |
| - Internal structure | 20.6 | \$310 | 24.6 | \$211 | \$95 | \$350 | \$40 | 13% |

| | | | | | | | | |
|--------------|--------------|----------------|--------------|----------------|--------------|----------------|--------------|-----------|
| NVH | 8 | \$110 | 8 | - | - | \$110 | \$0 | 0% |
| Paint | 4 | \$540 | 4 | - | - | \$540 | \$0 | 0% |
| Assembly | - | \$612 | - | - | - | \$432 | -\$180 | -29% |
| Tooling | - | \$389 | - | - | - | \$156 | -\$233 | -60% |
| Total | 382.5 | \$2,858 | 241.8 | \$1,261 | \$312 | \$3,040 | \$182 | 6% |

A sensitivity analysis comparing a number of production volumes can be found in Table 4.5.6.3.g below. A further production volume analysis can be found in Appendix A, section 7.1.1.

Table 4.5.6.3.g: Manufacturing sensitivity analysis

| Production | Category | Year 1 | Year 2 | Year 3 | Year 4 | Year 5 | Year 6 | Year 7 | Year 8 |
|----------------------|----------------------------|----------------|----------------|----------------|----------------|----------------|----------------|----------------|----------------|
| 60k | Capital costs (mils) | \$11.01 | \$11.01 | \$11.01 | \$11.01 | \$11.01 | \$1.09 | \$1.09 | \$0.74 |
| | Labor (mils) | \$6.50 | \$6.50 | \$6.50 | \$6.50 | \$6.50 | \$6.50 | \$6.50 | \$6.50 |
| | Utilities (mils) | \$2.94 | \$2.94 | \$2.94 | \$2.94 | \$2.94 | \$2.94 | \$2.94 | \$2.94 |
| | Interest (mils) | \$2.52 | \$2.52 | \$2.52 | \$2.52 | \$2.52 | \$2.52 | \$2.52 | \$2.52 |
| | Freight (mils) | \$1.50 | \$1.50 | \$1.50 | \$1.50 | \$1.50 | \$1.50 | \$1.50 | \$1.50 |
| | SG&A (mils) | \$1.43 | \$1.43 | \$1.43 | \$1.43 | \$1.43 | \$0.74 | \$0.74 | \$0.71 |
| | Annual Total (mils) | \$25.89 | \$25.89 | \$25.89 | \$25.89 | \$25.89 | \$15.28 | \$15.28 | \$14.91 |
| | BIW Total | \$432 | \$432 | \$432 | \$432 | \$432 | \$255 | \$255 | \$248 |
| 100k | Capital costs (mils) | \$11.01 | \$11.01 | \$11.01 | \$11.01 | \$11.01 | \$1.09 | \$1.09 | \$0.74 |
| | Labor (mils) | \$9.74 | \$9.74 | \$9.74 | \$9.74 | \$9.74 | \$9.74 | \$9.74 | \$9.74 |
| | Utilities (mils) | \$5.12 | \$5.12 | \$5.12 | \$5.12 | \$5.12 | \$5.12 | \$5.12 | \$5.12 |
| | Interest (mils) | \$2.52 | \$2.52 | \$2.52 | \$2.52 | \$2.52 | \$2.52 | \$2.52 | \$2.52 |
| | Freight (mils) | \$2.50 | \$2.50 | \$2.50 | \$2.50 | \$2.50 | \$2.50 | \$2.50 | \$2.50 |
| | SG&A (mils) | \$1.81 | \$1.81 | \$1.81 | \$1.81 | \$1.81 | \$1.12 | \$1.12 | \$1.09 |
| | Annual Total (mils) | \$32.71 | \$32.71 | \$32.71 | \$32.71 | \$32.71 | \$22.09 | \$22.09 | \$21.72 |
| | BIW Total | \$327 | \$327 | \$327 | \$327 | \$327 | \$221 | \$221 | \$217 |
| Cost Decrease | 24% | 24% | 24% | 24% | 24% | 13% | 13% | 12% | |

4.5.7. Cost Discussion

This discussion covers the cost evaluation methods used for both the Phase 1 and Phase 2 studies. Phase 1 only covered a basic analysis while Phase 2 went into far greater detail including full tooling and assembly analyses, conducted with assistance from Intellicosting and EBZ Engineering. The basics of the Phase 1 study are provided before delving into the Phase 2 study and some of the cost saving technology behind the Phase 2 HD BIW itself.

4.5.7.1 Phase 1 Cost Study

The Lotus Phase 1 study projected potential cost savings in a number of areas outside the body structure to partially offset the more expensive low-mass body structure. These non-BIW system cost reductions occurred because a substantial amount of mass was eliminated by using less material, parts integration allowing fewer components overall, and, in some cases, less expensive materials.

The cost weighting factors used for the cost analyses are the values published in the Phase 1 report; this chart is shown in Figure 4.5.7.1.a below.

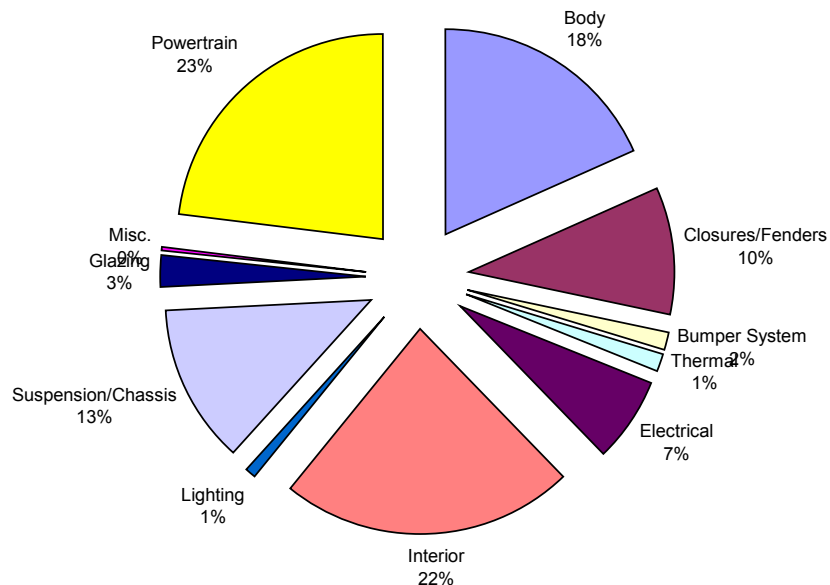

Figure 4.5.7.1.a: Estimated Vehicle System Costs

Table 4.5.7.1.a summarizes the Phase 1 study total vehicle cost; the body structure piece cost was estimated at 135 percent, or 35-percent higher than the baseline Venza BIW estimated piece cost. The average cost for non-body systems was estimated at 96 percent. The estimated weighted cost for the Phase 1 total vehicle, less powertrain, was 103 percent.

Table 4.5.7.1.a: Phase 1 HD Estimated Vehicle Cost Increase

| | Cost factor | Cost Weighting factor | Weighted Cost factor |
|--------------------------|--------------------|------------------------------|-----------------------------|
| Body | 135.0% | 18.0% | 24.3% |
| Non-Body | 96.0% | 82.0% | 78.7% |
| Totals | | | |
| | | 100.0% | 103.0% |
| Cost Differential | | | |
| | | | 3.0% |

The cost differentials for the various components and systems in the Phase 1 design can be converted into overall vehicle costs based on an average approximation of the indirect costs incurred by automakers and included in the selling price of a vehicle, such as the Toyota Venza. The 2009 Toyota Venza had a base invoice price of \$23,500. Dividing this cost by Toyota’s cost-to-price markup factor yields an estimated direct manufacturing cost to produce the Venza. Generally, estimating automobile industry direct costs from retail prices is done with a retail price equivalent (RPE) factor to account for the cost of production overhead, warranty, research and development, administrative, marketing, dealers, etc. Industry averages for this RPE factor typically range from 1.45-1.50 and a peer-reviewed study prepared for U.S. EPA indicates that Toyota’s RPE is 1.48 (Rogozhin et al, 2009). As a result, the direct manufacturing cost for the 2009 Toyota Venza is estimated to be \$15,878 (i.e. \$23,500 divided by 1.48).

The system costs for the 2009 Venza are estimated in Table 4.5.7.1.b; these values are based on the Estimated Vehicle System Costs shown in Figure 4.5.7.1.a and the estimated direct manufacturing cost derived above.

Also in the table are the resulting Phase 1 HD design’s estimated incremental costs based primarily on the 35-percent increase for the body structure cost (estimated at \$1,000) and the cost decreases in closures, fenders, electrical, interior, suspension, and chassis components (savings of over \$600). The BIW estimated cost is based on a 35 percent cost increase for piece cost, tooling, assembly, paint, and NVH materials. Detailed tooling and assembly cost analyses were beyond the scope of the Phase1 project.

The net result of the Phase 1 HD vehicle was a \$342 vehicle cost increase; the powertrain cost is not included in this number.

Table 4.5.7.1.b: Estimated direct manufacturing costs of the Toyota Venza baseline and Phase 1 High Development vehicle design

| Area/System | Baseline 2009 Toyota Venza | | | Lotus Phase 1 High Development Vehicle | | | | |
|---------------------------------|----------------------------|----------|---------------|--|---------------------|-------------|---------------|-----------------------|
| | Mass (kg) | Cost (%) | Cost (\$) | Mass (kg) | Mass reduction (kg) | Cost factor | Cost (\$) | Incremental cost (\$) |
| Body | 382.5 | 18 | 2858 | 221.1 | 161.4 | 135% | 3858 | 1000 |
| Closures/Fenders | 143.02 | 10 | 1588 | 84 | 59 | 76% | 1207 | -381 |
| Bumpers | 17.95 | 2 | 318 | 16 | 2 | 103% | 327 | 9 |
| Thermal | 9.25 | 1 | 159 | 9.3 | 0 | 100% | 159 | 0 |
| Electrical | 23.6 | 7 | 1111 | 15 | 8.6 | 96% | 1067 | -44 |
| Interior | 250.6 | 22 | 3493 | 152.8 | 97.8 | 96% | 3354 | -139 |
| Lighting | 9.9 | 1 | 159 | 9.9 | 0 | 100% | 159 | 0 |
| Suspension/Chassis | 378.9 | 13 | 2064 | 217 | 161.9 | 95% | 1961 | -103 |
| Glazing | 43.71 | 3 | 476 | 43.7 | 0 | 100% | 476 | 0 |
| Miscellaneous | 30.1 | 0 | 0 | 22.9 | 7.2 | 99% | 0 | 0 |
| Powertrain | 410.16 | 23 | 3652 | 356.2 | 54 | - | - | - |
| Total (excl. powertrain) | 1290 | - | 12,226 | 792 | 498 | 103% | 12,568 | 342 |
| Total (incl. powertrain) | 1700 | - | 15,878 | 1148 | - | - | - | - |

4.5.7.2 Phase 2 Cost Study

The following BIW cost discussion presents the comparison of the baseline, Phase 1, and Phase 2 BIWs including a comparison of the piece cost and the costs based on the detailed manufacturing report done as part of the Phase 2 study.

Assembled body costs for the Venza BIW are not public information, thus the costs for the 2009 Toyota Venza BIW were estimated using the methodology above (taken from the Phase 1 report). The full assembled body is estimated at 18 percent of the RPE value, giving a body cost of \$2858. This value is an estimate as the cost will vary by OEM and by platform as well as by the country the body is assembled in, the country of origin for the body parts and commodity price fluctuations for the materials.

Lotus contracted Intellicosting, a Detroit area company experienced in automotive component costing, to analyze all costs related to this study. Intellicosting does not apply recovery for scrap material in their calculations / methodology. Identical labor rates were used for both the baseline BIW and the Phase 2 BIW costing.

Intellicosting is widely used internationally by both OEMs and their suppliers. An example of the Intellicosting methodology is included in section 7.4 in the Appendix.

Intellicosting valued the Venza piece cost at \$1,207, leaving \$1,651 for the assembly, paint, tooling, and NVH costs. Paint and body NVH costs were determined through industry research and are estimated at \$540 while body specific NVH materials were estimated at \$39. Tooling costs per BIW were determined by amortizing the \$70 million tooling cost (estimated by Intellicosting) over three years of production at 60,000 units annually. This brings the tooling cost per BIW to \$389. The remaining \$683 is the estimated assembly cost.

Intellicosting also developed detailed piece costs for the Phase 2 HD BIW, which were \$1930.54. This gives a 160-percent piece-cost increase relative to the 2009 Toyota Venza BIW (\$1930.54/\$1207.32). Paint and NVH materials were estimated at \$540 and \$39 for the Phase 2 HD BIW as well. Tooling cost and assembly cost for the Phase 2 BIW are both substantially lower than for the Venza at \$156 and \$432 respectively due to the significantly decrease parts count (166 for the Phase 2 HD versus 419 for the Venza).

The part-by-part cost analysis for both bodies is included in Section 7.3, Appendix C.

Table 4.5.7.2.a below details the costs associated with producing a complete BIW for the baseline Venza, Phase 1, and Phase 2 bodies.

Table 4.5.7.2.a: Assembled BIW analysis

| Category | Venza | Phase 1 | Phase 2 Actual |
|------------------------------|---------|---------|----------------|
| Piece cost | \$1,207 | \$1,629 | \$1,930 |
| Relative piece cost | 100% | 135% | 160% |
| Assembly | \$683 | \$922 | \$432 |
| Paint | \$540 | \$729 | \$540 |
| Tooling | \$389 | \$525 | \$156 |
| NVH | \$39 | \$53 | \$39 |
| Total | \$2,858 | \$3,858 | \$3,098 |
| Difference relative to Venza | \$0 | \$1,000 | \$239 |

Table 4.5.7.2.b below breaks down the cost further with just the assembly, paint, tooling, and NVH cost analysis. These costs are approximately \$484 less for the Phase 2 HD design than for the baseline Venza. The cost increase for the Phase 2 BIW relative to the Venza is 108% (\$3,098/\$2,858).

Table 4.5.7.2.b: Assembly, paint, tooling, and NVH cost analysis

| Category | Venza | Phase 1 (135% SF) | Phase 2 Actual |
|------------------------------|---------|-------------------|----------------|
| Assembly | \$683 | \$922 | \$432 |
| Paint | \$540 | \$729 | \$540 |
| Tooling | \$389 | \$525 | \$156 |
| NVH | \$39 | \$53 | \$39 |
| Total | \$1,651 | \$2,228 | \$1,167 |
| Difference relative to Venza | \$0 | \$578 | -\$484 |

Table 4.5.7.2.c below shows the piece cost for the baseline Venza, Phase 1, and Phase 2 vehicles and the assembly, paint, tooling, and NVH costs in sub-categories. The Phase 2 piece costs are \$723 more than the Venza primarily because of the more advanced materials used. This cost increase is partially offset by the \$484 savings in assembly and tooling. The total BIW cost increase is \$239, or 8 percent higher than the Venza cost.

Table 4.5.7.2.c: Piece, assembly, tooling, paint, and NVH sub-category costs

| Category | Venza | Phase 1 | Phase 2 |
|--------------------------------------|---------|---------|---------|
| Piece cost | \$1,207 | \$1,629 | \$1,930 |
| Difference to Venza | \$0 | \$422 | \$723 |
| Assembly, Tooling, Paint, NVH | | | |
| Assembly, Tooling, Paint, NVH | \$1,651 | \$2,228 | \$1,167 |
| Difference to Venza | \$0 | \$578 | -\$484 |
| Total difference | | | |
| Total difference | 0 | \$1,000 | \$239 |

The assembly and tooling cost savings relative to the Venza help offset the 160-percent piece cost increase. See section 4.4.12.3 “Investment and Manufacturing Costs” and Section 10 of Appendix A for a detailed breakdown. The assembly and tooling costs used in this section are based on EBZ’s suggested amortization schedule unless otherwise noted.

The complete, assembled body for Phase 1 is more expensive than the developed Phase 2 body because a single scaling factor was used. The relative Phase 1 BIW piece cost was estimated to be 135-percent more than the baseline Venza; this value was used as a scaling factor to estimate the costs of assembly, paint, tooling, and NVH materials.

The actual manufacturing and tooling costs are significantly lower than the scaled Phase 1 costs and are also lower than the estimated assembly and tooling costs for the baseline Venza. This is due primarily to the reduced part count. These reduced costs helped offset the 160-percent piece cost increase. Paint and NVH materials were left unchanged from the Venza cost, which were estimated through industry research. The estimated Phase 2 assembled and painted body costs are \$239 greater than the estimated assembled Venza body costs.

To compare a variety of possible amortization schedules, an analysis with both the three and five year straight amortization (tooling and manufacturing) schedules was also done. This analysis is shown in Table 4.5.7.2.d below.

Table 4.5.7.2.d: Amortization schedule comparison

| Category | EBZ Recommended | 3 Year Amortization | 5 Year Amortization |
|-----------------------|-----------------|---------------------|---------------------|
| Piece cost | \$1,930 | \$1,930 | \$1,930 |
| Capital costs per BIW | \$184 | \$301 | \$186 |

| | | | |
|----------------------|----------------|----------------|----------------|
| Labor per BIW | \$108 | \$108 | \$108 |
| Tooling cost per BIW | \$156 | \$156 | \$94 |
| Utilities per BIW | \$49 | \$49 | \$49 |
| Interest per BIW | \$42 | \$42 | \$42 |
| Freight per BIW | \$25 | \$25 | \$25 |
| SG&A per BIW | \$24 | \$24 | \$24 |
| BIW Total | \$2,518 | \$2,635 | \$2,458 |

The results show a slight increase in BIW cost when amortized over three years (\$117 more) and a slight decrease over five years (\$60 less). This is a straight amortization schedule; these costs would be constant over the specified time period instead of decreasing as with the EBZ recommended amortization schedule. None of the three amortization schedules is depreciated.

An analysis was done to determine the cost impact of the Phase 2 BIW on the total vehicle costs. The summary of findings is based on the Phase 1 analysis (for non-body components) and the Phase 2 analysis (for the body structure). Table 4.5.7.2.e below lists the values calculated for this analysis.

Table 4.5.7.2.e: Phase 2 Estimated Vehicle Cost Increase

| | Cost factor | Cost Weighting factor | Weighted Cost factor |
|--------------------------|-------------|-----------------------|----------------------|
| Complete body | 108% | 18% | 19.4% |
| Non-body | 95% | 82% | 77.9% |
| Totals | | 100% | 97.3% |
| Cost Differential | | | -2.7% |

The resultant full vehicle (less powertrain) is estimated to cost 2.7% less than the baseline Venza based on a 5% cost savings from non-body components and an eight-percent increase from the body structure.

Table 4.5.7.2.f below shows the cost breakdown for the various body and non-body systems of the Venza and Phase 2 HD designs. As shown in the table, the estimated incremental cost of the body is \$239 (108 percent) higher than the baseline Venza. Including the cost savings from the closures, fenders, electrical, interior, suspension, and chassis components (estimated savings of over \$600), the net result of the full Phase 2 HD vehicle is actually an estimated \$419 decrease in total vehicle cost. Note: the Phase 1 report has details on these topics, including derivation of the estimated cost factors.

Table 4.5.7.2.f: Estimated direct manufacturing costs of the Toyota Venza baseline and Phase 2 HD vehicle designs

| Area/System | Baseline 2009 Toyota Venza | | | Lotus Phase 2 High Development Vehicle | | | | |
|-------------|----------------------------|----------|-----------|--|---------------------|--------------------------|-----------|-----------------------|
| | Mass (kg) | Cost (%) | Cost (\$) | Mass (kg) | Mass reduction (kg) | Total system cost factor | Cost (\$) | Incremental cost (\$) |
| | | | | | | | | |

| | | | | | | | | |
|---------------------------------|-------------|----------|---------------|-------------|------------|-------------------------------------|---------------|-------------|
| Body | 382.5 | 18% | 2858 | 241.8 | 140.7 | 108% | 3097 | 239 |
| Closures/Fenders | 143 | 10% | 1588 | 84 | 59 | 76% | 1207 | -381 |
| Bumpers | 17.95 | 2% | 318 | 2 | 2 | 103% | 327 | 9 |
| Thermal | 9.25 | 1% | 159 | 9.3 | 0 | 100% | 159 | 0 |
| Electrical | 23.6 | 7% | 1111 | 15 | 8.6 | 96% | 1067 | -44 |
| Interior | 250.6 | 22% | 3493 | 153 | 97.8 | 96% | 3354 | -139 |
| Lighting | 9.9 | 1% | 159 | 9.9 | 0 | 100% | 159 | 0 |
| Suspension/Chassis | 378.9 | 13% | 2064 | 217 | 161.9 | 95% | 1961 | -103 |
| Glazing | 43.71 | 3% | 476 | 43.7 | 0 | 100% | 476 | 0 |
| Miscellaneous | 30.1 | 0% | 0 | 22.9 | 7.2 | 99% | 0 | 0 |
| Powertrain | 410.2 | 23% | 3652 | 356 | 54 | - | - | - |
| Total (excl. powertrain) | 1290 | - | 12,226 | 817 | 527 | 96.6% (wt'd cost factor) | 11,807 | -419 |
| Total (incl. powertrain) | 1700 | - | 15,878 | 1163 | - | - | - | - |

Another analysis was performed to determine the sensitivity of the vehicle cost (less powertrain) to the percent contribution of the body to the vehicle cost makeup. The cost weighting factor was varied from 16 percent to 20 in two-percent (2%) increments to account for the vehicle body constituting a larger or smaller percentage of the total vehicle cost. For this sensitivity analysis, all other factors were the same as in Table 4.5.7.2.c. Table 4.5.7.2.g below shows very little variation (less than 0.6%) based on the body contribution to the full vehicle. This is because both the body and non-body components are estimated to be very close to the cost of the actual Venza systems. The non-body incremental cost factor is 95.0%, i.e., the average cost reduction for all non-body systems, less powertrain, is 5.0%. This number differs from the total non-powertrain number of 96.6% because it does not include the weighted BIW incremental cost factor.

Table 4.5.7.2.g: Phase 2 full vehicle sensitivity study

| | Incremental Cost Factor | Low Cost | | Central Estimate | | High Cost | |
|--|-------------------------|--------------|----------------------|------------------|----------------------|--------------|----------------------|
| | | Cost Portion | Weighted Cost Factor | Cost Portion | Weighted Cost Factor | Cost Portion | Weighted Cost Factor |
| Body | 108.0% | 16.0% | 17.3% | 18.0% | 19.4% | 20.0% | 21.6% |
| Non-body | 95.0% | 84.0% | 79.8% | 82.0% | 77.9% | 80.0% | 76.0% |
| Totals | - | 100.0% | 97.1% | 100.0% | 97.4% | 100.0% | 97.6% |
| Cost differential for total vehicle | - | - | -2.9% | - | -2.6% | - | -2.4% |
| Incremental vehicle cost | - | - | -\$460 | - | -\$419 | - | -\$378 |

The non-body cost factors in Tables 4.5.7.2.f and 4.5.7.2.g are based on estimates generated in the Phase 1 report. The numbers were a result of near 40% mass reductions while using similar, or in some cases, reduced cost materials for many of the components. A total vehicle, less powertrain, cost reduction of 3.4% is required to achieve a total vehicle savings, less powertrain, of \$419 for a body costing 8% more than the all steel baseline body.

The low mass body requires a new assembly plant to build it. The details of the assembly plant are included in the Appendix. It was assumed that an existing facility was updated with the required Phase 2 BIW hardware, i.e., there was no cost included for constructing a new building. Amortizing the cost of the new assembly plant into the BIW cost over a three year period increases the BIW cost factor by 10% over the non-amortized body cost, from 108% to 118%.

Combining Tables 4.5.7.2.a and Table 4.5.7.2.d yields a final amortized BIW cost. These costs are shown in Table 4.5.7.2.h.

Table 4.5.7.2.h: Fully Amortized Body in White Cost

| Category | EBZ Recommended | 3 Year Amortization | 5 Year Amortization |
|---|-----------------|---------------------|---------------------|
| Piece cost | \$1,930 | \$1,930 | \$1,930 |
| Capital costs per BIW | \$184 | \$301 | \$186 |
| Labor per BIW | \$108 | \$108 | \$108 |
| Tooling cost per BIW | \$156 | \$156 | \$94 |
| Utilities per BIW | \$49 | \$49 | \$49 |
| Interest per BIW | \$42 | \$42 | \$42 |
| Freight per BIW | \$25 | \$25 | \$25 |
| SG&A per BIW | \$24 | \$24 | \$24 |
| BIW Assembly Labor | \$432 | \$432 | \$432 |
| Paint | \$540 | \$540 | \$540 |
| NVH | \$39 | \$39 | \$39 |
| BIW Total | \$3,529 | \$3,646 | \$3,469 |
| % Cost Relative to Non Amortized Phase 2 BIW Phase 2 | 114% | 118% | 112% |

The cost for the BIW amortized over a three year period was substituted for the non-amortized BIW cost factor and the incremental vehicle costs were recalculated. Table 4.5.7.2.i below lists the total vehicle costs using the three year amortized BIW cost. The nominal estimate is \$133 less than the baseline vehicle.

Table 4.5.7.2.i: Phase 2 full vehicle sensitivity study

| | Incremental Cost Factor | Low Cost | | Nominal Estimate | | High Cost | |
|-----------------|-------------------------|--------------|----------------------|------------------|----------------------|--------------|----------------------|
| | | Cost Portion | Weighted Cost Factor | Cost Portion | Weighted Cost Factor | Cost Portion | Weighted Cost Factor |
| Body | 118.0% | 16.0% | 18.9% | 18.0% | 21.2% | 20.0% | 23.6% |
| Non-body | 95.0% | 84.0% | 79.8% | 82.0% | 77.9% | 80.0% | 76.0% |
| Totals | - | 100.0% | 98.7% | 100.0% | 99.2% | 100.0% | 99.6% |

| | | | | | | | |
|-------------------------------------|---|---|--------|---|--------|---|-------|
| Cost differential for total vehicle | - | - | -1.3% | - | -0.8% | - | -0.4% |
| Incremental vehicle cost | - | - | -\$206 | - | -\$133 | - | -\$60 |

A final cost analysis was done to determine the effect that having no cost reduction benefit for the mass reduced non-BIW systems, i.e., the non-body cost factor went from 95.0% to 100.0%. Table 4.5.7.2.j below lists the total vehicle costs using the three year amortized BIW cost and cost parity for all non-body systems less powertrain. The Nominal Estimate is \$514 more expensive than the baseline vehicle.

Table 4.5.7.2.j: Phase 2 full vehicle sensitivity study – Non-BIW Cost parity

| | Incremental Cost Factor | Low Cost | | Nominal Estimate | | High Cost | |
|-------------------------------------|-------------------------|--------------|----------------------|------------------|----------------------|--------------|----------------------|
| | | Cost Portion | Weighted Cost Factor | Cost Portion | Weighted Cost Factor | Cost Portion | Weighted Cost Factor |
| Body | 118.0% | 16.0% | 18.9% | 18.0% | 21.2% | 20.0% | 23.6% |
| Non-body | 100.0% | 84.0% | 84.0% | 82.0% | 82.0% | 80.0% | 80.0% |
| Totals | - | 100.0% | 102.9% | 100.0% | 103.2% | 100.0% | 103.6% |
| Cost differential for total vehicle | - | - | -1.7% | - | -1.2% | - | -0.7% |
| Incremental vehicle cost | - | - | \$457 | - | \$514 | - | \$572 |

4.5.7.3 Closures Piece Costs

CARB and EPA authorized a study in which Lotus would develop fully engineered closure systems. The piece and tooling costs are listed in Table 4.5.7.3 below. The hood is costed as a bolt-on fixed assembly without a hinge/latch reinforcement system. This approach eliminates the mass of hinges, springs, latch mechanism and hood inner reinforcements and maximizes the section strength of the front end. A fluid fill and check access panel is part of the front bumper assembly.

Table 4.5.7.3: Closure piece and tooling costs

| Part Number | Part Name | Material | Tooling Cost | Piece Cost |
|------------------------|--|--------------------|---------------------|-------------------|
| Closures | | | \$15,957,268 | \$1,144.48 |
| Liftgate | | | | |
| 7308-2610-001 | Liftgate inner | Magnesium - AM60 | 384,000 | 67.44 |
| 7308-2610-002 | Liftgate outer | Aluminum - 6063-T4 | 1,478,763 | 52.20 |
| 7308-2610-003 | Panel - Spoiler | PPO+PA Noryl GTX | 316,000 | 5.71 |
| 7308-2610-004 | Liftgate bracket – gas strut anchor - inner | Aluminum - 6063-T4 | 65,667 | 0.78 |
| 7308-2610-005 | Bracket – hinge upper | Aluminum - 6063-T4 | 63,433 | 1.28 |
| 7308-2610-005 | Bracket – liftgate hinge base + studs & pins | Aluminum - 6063-T4 | 60,737 | 2.77 |
| | | Sub-total | 2,368,600 | 130.18 |
| Door Front – LH | | | | |

| | | | | |
|------------------------|---------------------------------------|--------------------|------------------|---------------|
| 7308-2710-001 | Panel - Door outer - LH | Aluminum - 6063-T4 | 1,338,772 | 51.90 |
| 7308-2810-002 | Panel - Door inner - LH | Magnesium - AM60 | 231,500 | 42.26 |
| 7308-2810-003 | Beam – Reinf't Front Door | HSS-950 | 179,054 | 5.36 |
| 7308-2810-004 | Bracket- Frt. Dr. Hinge support | HSS-950 | 153,292 | 2.73 |
| 7308-2810-005 | Beam – Reinf.-Frt. Dr. outer | HSS-950 | 147,578 | 4.96 |
| 7308-2810-006 | Striker Asm.-Striker Plate | LCS | 43,012 | 2.31 |
| 7308-2810-007 | Hinge Asm. – Door upper | LCS | 88,188 | 19.67 |
| 7308-2810-008 | Hinge plate – outer - upper | LCS | 88,188 | 19.67 |
| 7308-2810-009 | Hinge plate – inner - upper | LCS | 44,293 | 3.16 |
| 7308-2810-010 | Hinge Asm. – Door lower | LCS | 88,188 | 19.67 |
| 7308-2810-011 | Hinge plate – outer - lower | LCS | 88,188 | 19.67 |
| 7308-2810-012 | Hinge plate – inner - lower | LCS | 44,293 | 3.16 |
| 7308-2810-013 | Striker – Front Door latch reinf't | HSS - 950 | 71,084 | 0.90 |
| 73082810-014 | Panel – Insert Frt Door | PPO - Unfilled | 191,000 | 5.08 |
| | | Sub-total | 2,796,630 | 200.50 |
| Door Front – RH | | | | |
| 7308-2710-001 | Panel - Door outer - RH | Aluminum - 6063-T4 | 1,338,772 | 51.90 |
| 7308-2810-002 | Panel - Door inner - RH | Magnesium - AM60 | 231,500 | 42.26 |
| 7308-2810-003 | Beam – Reinf't Front Door | HSS-950 | 179,054 | 5.36 |
| 7308-2810-004 | Bracket- Frt. Dr. Hinge support | HSS-950 | 153,292 | 2.73 |
| 7308-2810-005 | Beam – Reinf.-Frt. Dr. outer | HSS-950 | 147,578 | 4.96 |
| 7308-2810-006 | Striker Asm.-Striker Plate + wear pin | LCS | 0 | 2.31 |
| 7308-2810-007 | Hinge Asm. – Door upper | LCS | 0 | 19.67 |
| 7308-2810-008 | Hinge plate – outer - upper | LCS | 0 | 19.67 |
| 7308-2810-009 | Hinge plate – inner - upper | LCS | 0 | 3.16 |
| 7308-2810-010 | Hinge Asm. – Door lower | LCS | 0 | 19.67 |
| 7308-2810-011 | Hinge plate – outer - lower | LCS | 0 | 19.67 |
| 7308-2810-012 | Hinge plate – inner - lower | LCS | 0 | 3.16 |
| 7308-2810-013 | Striker – Front Door latch reinf't | HSS - 950 | 71,084 | 0.90 |
| 73082810-014 | Panel – Insert Frt Door | PPO - Unfilled | 177,000 | 5.08 |
| | | Sub-total | 2,298,280 | 200.50 |
| Door Rear - LH | | | | |
| 7308-2910-001 | Panel - Door rear outer - LH | Aluminum - 6063-T4 | 1,171,834 | 45.43 |
| 7308-2910-002 | Panel - Door rear inner - LH | Magnesium AM60 | 231,500 | 42.26 |
| 7308-2910-003 | Beam – Reinf't Rear Door | HSS - 950 | 186,220 | 5.36 |
| 7308-2910-004 | Striker Asm.-Striker Plate | LCS | 0 | 2.31 |
| 7308-2910-005 | Hinge Asm. – Door upper | LCS | 0 | 19.67 |
| 7308-2910-006 | Hinge plate – outer - upper | LCS | 0 | 19.67 |
| 7308-2910-007 | Hinge plate – inner - upper | LCS | 0 | 3.16 |
| 7308-2910-008 | Hinge Asm. – Door lower | LCS | 0 | 19.67 |
| 7308-2910-009 | Hinge plate – outer - lower | LCS | 0 | 19.67 |
| 7308-2910-010 | Hinge plate – inner - lower | LCS | 0 | 3.16 |
| 7308-2910-011 | Panel – Insert Frt Door | PPO - Unfilled | 175,000 | 3.91 |
| 7308-2910-012 | Striker – latch reinf't | Aluminum 6061 T4 | 167,009 | 8.91 |
| 7308-2910-013 | Bracket – rr dr hinge support | Aluminum 6063 T4 | 75,353 | 6.15 |
| 7308-2910-014 | Reinf't – rr dr outer | Aluminum 6063 T4 | 87,020 | 6.05 |
| 7308-2910-015 | Reinf't – rr dr inner | Aluminum 6063 T4 | 172,463 | 6.05 |

| | | | | |
|--------------------------------|---------------------------------|----------------------|------------------|---------------|
| | | Sub-total | 2,266,399 | 211.43 |
| Door Rear - RH | | | | |
| 7308-2910-001 | Panel - Door rear outer - LH | Aluminum - 6063-T4 | 1,171,834 | 45.43 |
| 7308-2910-002 | Panel - Door rear inner - LH | Magnesium AM60 | 231,500 | 42.26 |
| 7308-2910-003 | Beam – Reinf't Rear Door | HSS - 950 | 186,220 | 5.36 |
| 7308-2910-004 | Striker Asm.-Striker Plate | LCS | 0 | 2.31 |
| 7308-2910-005 | Hinge Asm. – Door upper | LCS | 0 | 19.67 |
| 7308-2910-006 | Hinge plate – outer - upper | LCS | 0 | 19.67 |
| 7308-2910-007 | Hinge plate – inner - upper | LCS | 0 | 3.16 |
| 7308-2910-008 | Hinge Asm. – Door lower | LCS | 0 | 19.67 |
| 7308-2910-009 | Hinge plate – outer - lower | LCS | 0 | 19.67 |
| 7308-2910-010 | Hinge plate – inner - lower | LCS | 0 | 3.16 |
| 7308-2910-011 | Panel – Insert Frt Door | PPO - Unfilled | 161,000 | 3.91 |
| 7308-2910-012 | Striker – latch reinf't | Aluminum 6061 T4 | 0 | 8.91 |
| 7308-2910-013 | Bracket – rr dr hinge support | Aluminum 6063 T4 | 75,353 | 6.15 |
| 7308-2910-014 | Reinf't – rr dr outer | Aluminum 6063 T4 | 87,020 | 6.05 |
| 7308-2910-015 | Reinf't – rr dr inner | Aluminum 6063 T4 | 172,463 | 6.05 |
| | | Sub-total | 2,085,390 | 211.43 |
| Front Fender Outer - LH | | | | |
| 7308-3110-001 | Panel - Front Fender Outer - LH | Aluminum - 6063 - T4 | 1,184,952 | 32.42 |
| | | Sub-total | 1,184,952 | 32.42 |
| Front Fender Outer - RH | | | | |
| 7308-3210-001 | Panel - Front Fender Outer - LH | Aluminum - 6063 - T4 | 1,184,952 | 32.42 |
| | | Sub-total | 1,184,952 | 32.42 |
| Hood | | | | |
| 7308-3310-001 | Panel - Hood outer | Aluminum - 6063 - T4 | 809,306 | 43.83 |
| 7308-3310-002 | Panel - Hood inner | Aluminum - 6063 - T4 | 962,759 | 81.77 |
| | | Sub-total | 1,772,065 | 125.60 |

4.5.7.4 Phase 2 HD BIW Technology

These analyses show that a holistic, total vehicle approach to weight reduction can minimize potential cost increases for utilizing a significantly lighter multi-material body structure as the vehicle basis. Additionally, a holistic approach needs to be taken to maximize the mass decompounding effect.

The Phase 2 BIW mass target was a maximum of 267.8 kg; this target was based on a total vehicle mass 30% lighter than the baseline Toyota Venza. This resulted in a maximum allowable BIW mass of 267.8 kg (382.5 x 0.70).

The total vehicle target was 1699.7 kg x 0.70, or 1189.8 kg. The Phase 1 High Development system masses were used for all areas but the BIW.

Due to changes necessary for crash and structural performance, the Phase 2 BIW mass is greater than the projected Phase 1 mass. A 42.2-percent mass reduction was estimated in the Phase 1 report while the Phase 2 mass reduction is 37.8 percent. The Phase 2 BIW mass of 241.8 kg (see BOM in Table 4.4.12.a for the mass summary) is 25.9 kg less than the Phase 2 mass requirement.

The fully assembled BIW costs for the baseline Venza, the Phase 1 HD BIW and the Phase 2 BIW are listed in Table 4.5.7.c. The Phase 2 project included detailed studies for tooling and assembly costs as well as BIW piece cost analyses for both the baseline Venza and the Phase 2 body. Independent experts in each field were utilized to analyze these areas.

The Phase 2 HD complete body (assembled, painted with NVH material added) is 108% more expensive than the baseline Venza BIW vs. the projected 135% cost from the Phase 1 report. This reduction is a direct result of lowering the parts count by 250 – Phase 2 BIW: 169 parts; 2009 Venza: 419 parts. Sixty (60) percent of the baseline parts have been eliminated through component integration and design changes. There are fewer tools required to make the body parts, the BIW assembly line is less complex and there are fewer assembly operations required to join the parts. This contributes to reduced BIW costs.

The joining process also contributed to lower costs. Friction spot joining for the aluminum components requires less energy than RSW (resistance spot welding) and is a less costly joining process. Kawasaki Robotics estimates a RSW is five times the cost of a friction spot joint. Even though the amount saved per weld is relatively small on an absolute basis, the total savings can be significant depending on the number of welds. As an example, the 2011 Jeep Grand Cherokee body has over 5,400 spot welds (<http://www.jaxcldr.com/2011-jeep-grand-cherokee.htm>).

A friction spot joint can utilize a smaller flange than RSW due to the reduced diameter of the flow drill relative to a welding head. This means that a significant material can be removed by reducing the flange width. A typical flange width is 25 to 30 mm for the RSW process. A 20 mm flange was used for the low mass body panels.

Additionally, the continuous beads of structural adhesive assist in creating a stiffer body structure by bonding 100 percent of the panel surfaces together. This increases the body stiffness with little mass penalty; the mass of the structural adhesive for the Phase 2 BIW is 1.4 kg.

Friction spot joining occurs in the plastic region of the material and does not change the material properties. Structural adhesives do not degrade the parent material properties. Resistance spot welds affect the parent material properties because the material changes phase during the welding process. The combination of the greatly reduced FSJ vs. RSW cost (Kawasaki estimates an FSJ is 1/20th the total cost of a RSW: <http://www.khi.co.jp/english/robot/product/fsj.html> - p.3) and the increased body stiffness

achieved by using continuous adhesive bonding rather than by adding material to the structure helps to lower BIW assembly costs.

4.5.8. Application of Results to Other Vehicle Classes

Task 4 of Lotus Engineering Inc.'s contract with the California Air Resources Board stipulated that Lotus investigate the application of the study results to other vehicle classes using the concepts in the above study. This section presents the data for scalability broken down into the eight previously defined vehicle systems: body-in-white, closures and fenders, interior, chassis and suspension, front and rear bumpers, thermal (HVAC), glazing, and electrical and lighting. Powertrain was not included in Phase 2 of this report, but can be scaled as well.

The vehicles discussed in this section are the standard micro car/A-segment, mini car/B-segment, small car/C-segment, midsize car/D-segment, and large car/E-segment passenger cars; small, midsize, and fullsize SUVs; minivans; and compact and fullsize pickup trucks.

4.5.8.1. Body-in-White

A variety of materials and methods were investigated as part of the Phase 2 D vehicle body-in-white development. These materials and construction methods – primarily the use of modularization and the expanded use of lightweight materials – are all applicable outside of the specified Toyota Venza CUV-class vehicle. This section discusses the materials and manufacturing techniques used in engineering the Phase 2 HD vehicle.

It is important to note that Ford has made public that the 2014 F-150 pick-up body structure will be a riv-bonded all aluminum structure. The sales for the F-150 series are approximately 400,000 annually. This will be the highest volume aluminum body structure in production and is approximately an order of magnitude greater than any current production aluminum body such as those used on the Audi A8 and the Jaguar XJ (sources: July 27, 2012, 12:01 AM Wall Street Journal Blog and <http://www.edmunds.com/car-reviews/top-10/top-10-best-selling-vehicles-for-2011.html>).

4.5.8.1.1. Modularization

Modularization is the process of integrating a variety of components into a larger sub-system, or module. The Phase 2 BIW reduced the part count from the baseline Toyota Venza's 269 individual parts to 169 parts. Modularization can be applied across a wide variety of vehicle classes to lighten the vehicle, decrease vehicle parts count, and improve production efficiency thereby decreasing production costs.

The scalability of this concept is already being applied to low-volume, niche vehicles, as mentioned in the Phase 1 report. Bentley's 2011 Mulsanne uses a single stamping for the A- and C-pillars, roof, and rear-quarter panels. The Lotus Evora also uses a modular

structure, with three different aluminum sub-sections for the chassis – front, passenger cell, and rear. The Dodge Nitro uses a modular door assembly that integrates the interior trim panel, window regulator assembly, audio, and electrical. A modular design has no adverse effects on vehicular safety; structural analyses will drive the design to the appropriate level of function required for the model.

This simplification technique can be applied to every vehicle class from heavy-duty, full-size pickup trucks to micro cars for effective weight loss.

4.5.8.1.2. Materials

Lotus also utilized advanced, lightweight materials in designing the Phase 2 HD vehicle. These materials, like modularization, can be scaled to nearly any vehicle class. A number of lightweight materials are being utilized throughout the automotive industry already, including high strength steels, aluminum, magnesium and composite materials. These materials were used in the Phase 2 body structure.

Lightweight material selection needs to be based on vehicle requirements such as durability cycle and cargo and towing capacity. For example, body-on-frame, full-size pickup trucks and some SUVs are required to tow extremely heavy loads and haul thousands of pounds of cargo. Due to the structural requirements associated with these conditions, materials such as aluminum are not used to replace the steel used to construct the frame. Non-ferrous materials such as aluminum, magnesium and composite materials can be used for non-frame components such as the body structure, closures and panel reinforcements.

Lotus worked collaboratively with Alcoa (aluminum material data and test coupons), Allied Composites (PET sandwich floor panels and material data), Henkel (galvanic coatings, structural adhesives, nylon B pillar reinforcements, coupon treatment and joining, coupon laboratory testing and material data), Kawasaki (Friction Spot Joining of coupons), and Meridian (magnesium material data and test coupons). Additionally, the above suppliers participated in the design process to ensure conformance to “best practices” for their respective materials. The materials and processes used for the Phase 2 BIW are all currently available and used for automotive and non-automotive products.

4.5.8.1.3. Aluminum Extrusions and Stampings

Lightweight metals such as aluminum are being used in BIWs from large luxury cars such as the Jaguar XJ to sports cars such as the Lotus Evora and Exige S (V6), which show the variability in design. Jaguar’s use of an aluminum body structure allowed the British firm to reduce the curb weight of its flagship XJ large sedan around 200 kilograms (440 pounds) compared to other large luxury vehicles⁴. Other examples of the scalability of aluminum extrusions include Audi’s Space Frame architecture, which is scaled and utilized in everything from the small A4 to the large A8. Aston Martin also uses the scalability of aluminum in its DB9 and Rapide sports cars, which are based on its VH (vertical

horizontal, named for the ability to lengthen and shorten it in both dimensions) architecture. Evidence of the scalability of aluminum stampings can be found in the Bentley Mulsanne's roof, fenders, and a number of aluminum hoods such as that on the Ford Mustang.

As mentioned in the materials section, aluminum cannot be used for some structural components of heavier duty vehicles such as full-size pickup trucks. Aluminum extrusions aren't generally suitable for use in pickup truck frames due to the significant differences in stiffness as shown by the Young's Moduli in section 4.2.2. The Young's Modulus for steel is greater than 210,000 MPa and is 70,000 MPa for aluminum, showing steel's greater resistance to bending under load.

4.5.8.1.4. Magnesium Castings

The magnesium castings used in the Phase 2 HD vehicle can be scaled as well and have been used in high-end vehicles such as BMWs, Chevrolet Corvettes, and Dodge Vipers. BMW uses magnesium in its engine blocks for weight reduction, the Corvette Z06's front cradle is made from cast magnesium which is 35-percent lighter than the previous cast aluminum structure⁴, and the Viper's dash module is cast from magnesium which reduced mass by 68 percent compared to the previous steel casting. The Ford Flex uses a magnesium front end structure which supports the radiator and condenser. The Phase 2 BIW utilizes magnesium castings for the front end structure, the front of dash and the rear wheelhouse area.

4.5.8.1.5. High Strength Steel

High strength steels require little modification to put into use on vehicles as the manufacturing techniques are nearly identical to those already in place throughout the automotive industry. The weight savings comes through the ability to use less material to make the same strength part; high strength steels are already beginning to be used extensively in production vehicles. As an example, the Mercedes Benz E class uses over 70% HSS. The Phase 2 body incorporates steel B pillars. Light- and heavy-duty pickup trucks incorporate high-strength steel into frames in order to increase the strength of the frame while simultaneously reducing weight by using less material than for a comparable conventional steel frame.

4.5.8.1.6. Composites

Composite materials are used in the Phase 2 HD floor and rear load floor. Composite materials such as carbon fiber reinforced plastic are currently extensively used in motorsports and high-end sports cars. Until recently, the materials and manufacturing techniques were too expensive for widespread use in the automotive industry. Examples of composite usage include entire carbon fiber monocoques in Formula 1 cars, Lamborghini's Sesto Elemento concept made entirely from the composite, the carbon fiber monocoque in

the production McLaren MP4-12C, Volkswagen XL1 concept, and smaller items such as the roof on BMW's M3 and M6. Carbon fiber suppliers including Plasan, SGL, Toray, and Fiberforge are delivering carbon composite components for the automotive industry. BMW recently announced its upcoming i3 electric city car's passenger cell will be made from carbon fiber as well – the first truly mass produced passenger cell to be made from carbon.

Carbon fiber is acceptable for use in production vehicles that see relatively small loads, but may not be acceptable for use in load-bearing components of heavier-duty vehicles such as pickup trucks. Carbon fiber has been shown to withstand high loads on vehicles such as Formula 1 cars, but these racing parts are extremely expensive to produce and do not need to meet the durability cycles required for production vehicles. The durability of carbon fiber under high loads – such as those seen in a pickup truck – is unknown. Carbon fiber usage on low volume, lower stress vehicles in non-structural areas, such as body panels, will lead the way for integration into mainstream passenger cars. Much development work is being done to reduce the cost of carbon fiber parts for higher volume production. Globe Machine Mfg. Company, a Tacoma, Washington based firm, has production machinery capable of 17 minute cycles for large automotive panels, a substantial reduction from the typical autoclave process cycle time.

4.5.8.1.7. Scalability Summary

It is possible to lighten BIW structures of vehicles of all classes using the materials and methods described above, but it is unlikely the same weight savings will be achieved in smaller vehicle classes. This is partially due to simple dimensional constraints such as the seats – which must be large enough to hold a 95th-percentile American male – and the relationship between the driver, pedals and steering wheel. Other constraints include crash protection, which due to the smaller crumple zone, typically requires the use of thicker (and thus heavier) steel to make the vehicles safe. Conversely, this may also allow manufacturers to realize a greater mass reduction in vehicles larger than the Venza. Table 4.5.8.1.7.a lists the potential relative mass reductions based on specific density and the projected curb weight mass savings relative to the baseline Toyota Venza.

All of the vehicles mentioned in this section, with the exception of the concept vehicles, meet or exceed federal safety standards and use different ratios of the same materials used in the Phase 2 HD vehicle. The wide variety of vehicle classes and sizes mentioned using these materials demonstrates that when properly engineered, the materials and manufacturing methods can be scaled while maintaining safety. Composites have proven to be exceptionally safe in motorsports, with the structures designed and tested to withstand the extreme forces of high speed collisions. Aluminum extrusions and castings can be selectively used in crumple zones to deform and absorb energy while high strength steel can be used in areas that need to remain rigid and intact in the event of an accident.

Vehicle requirements may mean that not all of the lightening methods used to create the Phase 2 HD vehicle can be applied to every vehicle, such as larger, BOF pickup trucks and SUVs. They require high towing and cargo capacities, necessitating the use of heavier-duty materials, such as described in the materials portion of this section. While the

same multi-material unibody construction can't be used for vehicles such as the Chevrolet Silverado or Suburban – which can tow up to 10,700 and 8500 pounds in half-ton, light-duty specification and the heavy-duty, full-ton Silverado pickup can tow up to 21,700 pounds when properly equipped – the same methods used for the interior, glazing, HVAC system, and electrical system can be applied. The chassis lightening methods cannot be fully utilized and the suspension must be built for heavy-duty applications, which means it can't be fully lightened either.

An example of capacity decrease from body-on-frame construction to unibody construction is the new Ford Explorer. For 2011, Ford switched the Explorer to unibody construction for weight savings purposes, decreasing the BIW mass by 58 kg and decreasing maximum towing capacity by 2400 pounds to 5000 pounds. Both the 2011 Jeep Grand Cherokee and 2011 Dodge Durango are unibody vehicles as well and can tow 7400 pounds each, but weigh around 5200 pounds each so equipped compared to 4400 pounds for the Explorer, demonstrating the necessary, structural, heavy reinforcements to allow the greater capacity.

The Toyota Yaris BIW shown in Figure 4.5.8.1.7.a below is an example of a mini car body structure, for which the Phase 2 BIW weight reduction does not scale directly. This is due to the previously mentioned dimensional constraints, such as those between the B-pillar and dashboard, which can only decrease so far in order to maintain a comfortable driving position and relationship to the dashboard for safety. This means that the Yaris and Phase 2 HD vehicle will have a similar amount of material between the driver's seat and dashboard. The small crumple zone ahead of the firewall can also be seen in this picture, which would have to be reinforced on this size car to maintain crash worthiness and would add weight. This BIW weighs 228 kg, which is approximately the same mass as the significantly larger Phase 2 HD BIW.



Figure 4.5.8.1.7.a: Toyota Yaris body-in-white structure

The Toyota Corolla BIW pictured in Figure 4.5.8.1.7.b is another example of a small car for which the weight savings may not reach the Phase 2 level. The same dimensional constraints as with the mini car apply. Reducing the BIW mass is still possible. The Corolla BIW weighs 289 kg, which is significantly heavier than the larger Phase 2 HD body.



Figure 4.5.8.1.7.b: Toyota Corolla body-in-white structure

The Audi A4 BIW structure pictured below in Figure 4.5.8.1.7.c is an example of a midsize car as defined by the EPA. It weighs 306 kg or approximately 25 percent more than the Phase 2 HD vehicle. Midsize cars are projected to approach the weight savings of the Phase 2 HD vehicle. The crumple zone is larger, which allows for thinner, lighter material

to absorb the crash energy. An extreme analogy to clarify this point is that if a vehicle had a 50-foot long crumple zone, the energy could be absorbed by foam rather than metal. The proportion of weight in the BIW between the driver's seat and dashboard also decreases relative to the body weight increase.



Figure 4.5.8.1.7.c: Audi A4 body-in-white structure

Audi's A7 BIW structure pictured below in Figure 4.5.8.1.7.d could realize a potential weight reduction close to the 40 percent of the Phase 2 HD BIW for the reasons given for the A4 BIW. The A7 BIW structure currently weighs 349 kg, over 100 kg more than the Phase 2 HD BIW.



Figure 4.5.8.1.7.d: Audi A7 body-in-white-structure

Body-in-white data for all of the vehicles listed above, along with the BIW volumes, densities, and specific densities are shown in Table 4.5.8.1.7.a below. Length, width, and height are given in inches and are used with a shape factor to calculate the BIW volume in

cubic feet. The shape factor is based on the bodystyle, i.e. sedan, wagon, SUV, etc., and is shown in Table 4.5.8.1.7.b. The density is then determined by dividing the BIW mass in kg by the BIW volume. Specific density is determined by dividing an example BIW density by the Phase 2 HD density, thus the Phase 2 HD BIW specific density is equal to 1.0 and is unitless.

Table 4.5.8.1.7.a: Body-in-white specific densities

| Vehicle | Mass (kg) | Weight (lbs.) | BIW Dimensions | |
|--------------------|-----------|---------------|------------------------------|--------|
| ARB Phase 2 HD BIW | 260.8 | 573.8 | Length (in.): | 180.04 |
| | | | Width (in.): | 75.79 |
| | | | Height (in.): | 53.94 |
| | | | Volume (cu. ft.): | 374.67 |
| | | | Density (kg/cu. ft.): | 0.70 |
| | | | Specific Density (unitless): | 1.00 |
| Toyota Yaris BIW | 228.0 | 501.6 | Length (in.): | 133.07 |
| | | | Width (in.): | 66.93 |
| | | | Height (in.): | 51.57 |
| | | | Volume (cu. ft.): | 232.79 |
| | | | Density (kg/cu. ft.): | 0.98 |
| | | | Specific Density (unitless): | 1.41 |
| Toyota Corolla BIW | 289.0 | 635.8 | Length (in.): | 160.71 |
| | | | Width (in.): | 49.09 |
| | | | Height (in.): | 84.33 |
| | | | Volume (cu. ft.): | 315.20 |
| | | | Density (kg/cu. ft.): | 0.92 |
| | | | Specific Density (unitless): | 1.32 |
| Audi A4 BIW | 306.0 | 673.2 | Length (in.): | 168.50 |
| | | | Width (in.): | 69.69 |
| | | | Height (in.): | 48.43 |
| | | | Volume (cu. ft.): | 272.52 |
| | | | Density (kg/cu. ft.): | 1.12 |
| | | | Specific Density (unitless): | 1.61 |
| Audi A7 BIW | 349.4 | 768.7 | Length (in.): | 174.41 |
| | | | Width (in.): | 74.80 |
| | | | Height (in.): | 48.03 |
| | | | Volume (cu. ft.): | 304.41 |
| | | | Density (kg/cu. ft.): | 1.15 |
| | | | Specific Density (unitless): | 1.65 |

Table 4.5.8.1.7.b: Shape factors

| | | |
|----------|----------------------|--|
| Volume = | Sedans: | $((\text{Wheelbase} \times \text{Height}) + ((\text{Length} - \text{Wheelbase}) \times 0.5 \times \text{Height})) \times \text{Width}$ |
| | SUVs and Hatchbacks: | $((0.33 \times (\text{Length} - \text{Wheelbase}) \times \text{Height}) + (\text{Wheelbase} \times \text{Height}) + (0.67 \times (\text{Length} -$ |

| | | |
|--|----------------|--|
| | | $Wheelbase * 0.5 * Height * Width$ |
| | <i>Trucks:</i> | $((Bed\ Length * 0.5 * Height) + (0.5 * (Length - Bed\ Length) * Height) + (0.5 * (Length - Bed\ Length) * 0.5 * Height)) * Width$ |

4.5.8.2. Closures

Lotus Engineering investigated a wide variety of materials to use to construct lightweight vehicular closures. These closures have already become a focal point for mass reduction due to the relative lack of complexity and ease of integration. A number of lightweight materials and manufacturing methods are already in production, including the use of a magnesium casting for the Lincoln MKT rear hatch. Lotus used low-mass materials to lighten vehicular closures and their fixtures, which can be scaled to nearly any vehicle class.

For example, the magnesium used in the tailgate can be used in non-structural components because the metal is too brittle to withstand crash events. Current thermoplastic body panels have limits on how large they should be manufactured due to thermal expansion characteristics.

4.5.8.2.1. Injection Molding

Injection molded plastics are currently used in industries ranging from toy making to the automotive industry. The wide variety of applications for injection-molded parts can already be seen in industry. Lotus applied modularization to a number of door components – including the structural B pillar reinforcements and window-glass channel – to allow for further weight savings. The scalability of modularization and castings was discussed in the previous section.

4.5.8.2.2. Mild Steel Castings

Lotus' closure designs call for the use of mild steel castings – a material and manufacturing technique already in use in vehicles that meet or exceed federal safety standards – for the majority of the door hinges. These parts have proven performance in vehicle crashworthiness. Thus, scaling the use of mild steel castings and injection molding to save weight will have no adverse effect on vehicle safety.

4.5.8.2.3. Scalability Summary

Although closures are already a focal point for mass reduction, increased weight savings are possible and unlike the BIW, likely proportionally scalable between vehicle classes. This is due to the use of modularization and increased use of lightweight materials in the Phase 2 HD vehicle while typical closures in every vehicle class are primarily constructed from heavier mild steel. Closures are also relatively unaffected by safety limitations as the

majority of the vehicle crash structure is engineered into the BIW. High strength steel side door beams have been refined to the point where they are lightweight and effective. Closures are dimensionally limited in that they should provide relative ease of access to the vehicle, i.e. doors should allow passengers to get into and out of the vehicle relatively easily, trunks/tailgates should provide adequate storage access, and the hood should provide an adequate opening for maintenance access.

4.5.8.3. Front and Rear Bumpers

Bumpers are engineered to pass federal vehicle safety requirements and simple beams with energy absorbing materials and stylized cosmetic fascias are generally adequate to pass these tests. Current bumpers are generally constructed from steel extrusions, although some are aluminum and magnesium. Lotus chose to use aluminum extrusions for the front and rear beams as it reduced vehicle mass and remained within the cost target. Aluminum extrusions are easily scalable as previously discussed in the BIW section and are already in use on vehicles that meet federal safety requirements, including the standard Toyota Venza rear bumper system.

4.5.8.4. Glazing (Windshield, Backlight, Doors, Sunroof, Fixed Panels)

Lotus investigated the possibility of using silicate treated polycarbonate when analyzing glazing options for the Phase 2 HD vehicle, but concluded the material may not be ready for widespread use on vehicle glazing by the 2020 time frame. This represented a conservative approach, but utilizing standard vehicle glass ensures the technology is readily scalable and that the vehicles will meet or exceed federal safety standards.

4.5.8.5. Interior

The scalability of the Phase 2 HD vehicle interior is based primarily on engineering and design concepts as vehicle interiors have different requirements. For example, Venza customers don't have the same interior expectation as either a Mercedes-Benz S-Class customer or a Lotus Exige customer. The primary engineering and design techniques used – systems integration, and seat, infotainment and instrument panel redesign – can be scaled to a variety of vehicles.

4.5.8.5.1. Seats

Different vehicle classes have different seat requirements – compare the lightweight bucket seats in the Lotus Exige to the 16-way power seats in the Mercedes-Benz S-Class – but all can be lightened through the use of new, lightweight foam and different

construction techniques such as using a foam suspension rather than metal. Seat scalability is already in use today as seats of a wide variety of shapes, sizes, and comfort levels appear in every vehicle on the road. Seats can also be carried across to a number of vehicles within a manufacturer's lineup, reducing development costs and providing greater economies of scale.

4.5.8.5.2. Electronic Transmission and Parking Brake Controls

Fully electronic transmission and parking brake controls are two ways to reduce weight in any vehicle and are independent of vehicle size. These technologies are being applied to a variety of vehicles. Ferrari, Mercedes-Benz, and Jaguar all use fully electronic transmission controls. Vehicles as small as GMC's Granite concept have used these technologies. It is important to note that electronic transmission systems work best with transmissions engineered for electronic actuation as the mass saved by eliminating the mechanical linkage will be added back when a servo-actuator is added. Electronic parking brakes eliminate the need for a mechanical linkage and can be integrated into an existing touch screen. Audi currently uses electronic parking brakes on vehicles such as its S4 sedan.

4.5.8.5.3. Instrument Panel

Instrument panels (IPs), for the most part, are currently designed using hardware tailored to each vehicle. Replacing the standard physical instrument panel with an OLED display reduces weight and can be scaled to every vehicle. Displays like this are currently used on high-end cars such as the Jaguar XJ, but are beginning to appear in mainstream cars such as the Ford Edge.

A similar system could be used to reduce the weight of the infotainment display. A transparent OLED (organic LED) touchscreen near the windshield could replace the navigation display and be scaled to any vehicle. Radio functions could then be controlled via personal music devices such as an iPod touch – as in the Ferrari F430 Scuderia – or an iPad. Capacitive touch sensitive buttons as in the Chevrolet Volt help to slightly reduce weight and can be scaled to any vehicle as well. This is shown in the emergence of touch sensitive consumer goods and the Jaguar XF and XJ, where even the dome lights and glovebox are controlled via touch sensitivity.

The engineering and construction technique used to create the IP and dash panel can also be scaled to other vehicle classes. The Phase 2 IP would integrate seamlessly into the cast magnesium dash panel, with integrated support brackets to ensure that it would meet federal safety standards. The gauge cluster in front of the driver is primarily supported by the collapsible, cast magnesium steering column, which is a primary connection to the vehicle. This design approach is scalable to other vehicles.

4.5.8.5.4. Center Console

Lotus simplified the number of parts required to create the center console, creating a design that can be scaled to virtually any center console design. This approach means that fewer parts need to be redesigned and retooled for manufacturing. The composite center console design can be scaled as shown by examples of the scalability and variability of composite design in the BIW section. The plastic material used for the center storage bin can also be scaled up or down as it's used in a wide variety of automotive and non-automotive products. The foam and leather used for the top of the armrest can also be scaled up or down as described in the seats section.

4.5.8.5.5. Noise Insulation

Active noise cancellation can be used to replace standard noise insulating materials and can be scaled to smaller and larger vehicle classes very easily. Noise cancellation eliminates heavy noise insulating materials by utilizing the sound system and microphones already built into the vehicle. This technology is currently used on the Chevrolet Equinox where General Motors tuned the software to cancel out the harsh engine noise at low RPM to allow the engine to idle lower and achieve a higher fuel economy rating. It is also used on high-end headphones to eliminate ambient noise and on airplanes to reduce wind noise while flying. This demonstrates the applicability of this technology to vehicles of all shapes and sizes and its ability to reduce the amount of heavy noise insulating material necessary by tuning it to cancel out wind, road, engine, and other ambient noise.

4.5.8.5.6. Interior Trim

Lotus primarily looked at system integration and elimination in order to reduce the weight of the Venza's interior trim for the Phase 2 HD vehicle. This means that the interior trim weight reductions can be scaled to a wide variety of vehicle classes. Carpeting can be removed from any vehicle and replaced by a varying size floormat as in the Phase 2 HD vehicle and evidenced by vehicles such as the Lotus Exige and Ferrari F430 Scuderia. Both have bare aluminum floors with floor mats. A similar technique is used to decorate wood and tile floors in houses, where the owner places a rug on a hardwood floor.

Other interior trim, such as sunvisors and pillar panels can be scaled. Faurecia, an innovative Tier 1 interior supplier (BMW, Audi, GM, etc.), and Trexel, the MuCell (an air injected plastic) supplier, are working on new, lighter coverings that can be scaled just as easily as the plastics currently used. Door panel mass has also been significantly reduced in the Phase 2 HD vehicle by merging the door panel trim with the inner door structure; this concept can be applied to any vehicle. Additionally, the physical door handle and connections were removed and replaced by lightweight capacitive switches molded into the door module itself. This is similar to the door module and electronic locking mechanisms already in use in the Aston Martin lineup, Chevrolet Corvette, Cadillac CTS Coupe, and Nissan GT-R. These can be used on any size vehicle.

4.5.8.5.7. HVAC Ducting

Lotus looked at a number of options to reduce the mass of the heating, ventilation, and air-conditioning systems for the Phase 2 HD vehicle. These systems are all very well developed and further mass reductions are extremely difficult. Mass reductions of the ducting system used to deliver the heated or cooled air to the passenger compartment can be achieved using new materials and are scalable. A MuCell foamed plastic technology was incorporated that offered reduced mass and improved thermal performance. MuCell foamed plastic parts can replace traditional vehicle ducting and are readily scalable.

4.5.8.6. Chassis and Suspension

A wide variety of components are included under the chassis and suspension category including wheels and tires, brakes, steering, and the suspension system. These components have been a focal point of mass reduction in order to reduce unsprung vehicle weight and correspondingly increase ride and handling performance.

4.5.8.6.1. Suspension and Steering

The selected suspension and steering components can be scaled to a variety of vehicle classes using materials and manufacturing technologies previously discussed. The Venza's standard springs were replaced with high strength steel units, which are used on high-end BMWs. Lotus also replaced the Venza's standard steel upper-spring seat with a glass-filled nylon unit, which is used on the Mazda5. Lightweight cast magnesium, which was previously discussed in the BIW section, was used for the front sub-frame; a magnesium sub-frame is used on the Corvette Z06. A simple and easily scalable hollow stabilizer bar – used on a wide variety of performance vehicles for weight savings – replaced the solid steel unit on the Venza.

The Venza's cast iron suspension knuckles were replaced with cast aluminum knuckles such as those offered on current Chrysler minivans. Lotus used a design similar to that on the Alfa Romeo 147 for the rear knuckles and one similar to the Volkswagen Passat's for the front knuckles, both of which are more compact and lighter than the stock Venza's.

Lotus utilized foam reinforced front lower-control arms to reduce the weight of the Phase 2 HD suspension. These are single piece stampings and as such, can be scaled using similar techniques to those previously described in the BIW section.

4.5.8.6.2. Braking System

Lotus evaluated a number of braking solutions for use on the Phase 2 HD vehicle including the electronic parking brake mentioned earlier. This system eliminates the physical connection hardware and uses a solenoid actuated integrated parking brake caliper rather than a specific parking brake mechanism to reduce weight.

The hybrid powertrain of the Phase 2 HD vehicle necessitated the use of a hydraulic brake pump rather than a vacuum driven brake pump. This type of pump is already in use on hybrids such as the Toyota Prius and the Ford Escape. The brake rotors themselves are new dual cast rotors (cast aluminum hub with cast iron outer ring) rather than single piece cast iron rotors. Brembo designed the brakes and they are currently available.

Lotus also chose to use Brembo's fixed aluminum front calipers, which are cast from aluminum to save weight over traditional cast iron calipers. The fixed caliper design also offers additional weight savings. Brembo already produces this style of caliper in a variety of sizes for different vehicle classes. The rear brakes on the Phase 2 HD vehicle use floating aluminum calipers, which are already in production.

4.5.8.6.3. Tires and Wheels

The tire and wheel technologies chosen for the Phase 2 HD vehicle are scalable based on wheel diameters. Wheels made from a variety of materials – cast steel alloys, cast aluminum alloys, and even forged aluminum alloys and forged magnesium⁷ – are currently offered in all sizes and styles. The cast aluminum alloy wheels chosen for the Phase 2 HD vehicle are currently manufactured in sizes as small as 15 inches as on the Toyota Prius up to sizes over 19 inches as on the Audi R8. Tires are also easily scalable as shown by the varying widths and side profile heights currently offered by tire manufacturers.

Lotus also eliminated the spare tire due to the availability of light weigh options in production now including run-flat tires and tire repair kits. The spare tire can be removed and either run-flat tires or a tire repair kit added to replace the spare tire on virtually any passenger car or truck. A spare tire is an option on the Dodge Challenger and not available on the Chevrolet Cruze Eco with a manual transmission.

4.5.8.7. Electrical

The electrical harnesses on the Phase 2 HD vehicle use thinwall, plastic-coated, copper-clad aluminum wiring. Copper-clad aluminum wiring is already in production while thinwall is currently being evaluated for production use and further weight savings. This technology can easily be applied to most vehicles. This is evidenced by the 2011 Toyota Yaris' use of CCA aluminum wiring harness manufactured by Sumitomo Electric Industries.

4.5.8.8. Powertrain

Phase 2 of Lotus' contract with the CARB did not require the evaluation of vehicle powertrains, but they are very scalable. This is evidenced by the wide variety of vehicles on the road today with a broad range of powertrain offerings. Vehicles today come with everything from V-8s coupled to eight-speed automatic transmissions to hybrids and pure electric vehicles. Vehicles can be engineered to accept a wide variety of powertrains as evidenced by the Chevrolet Volt series hybrid utilizing the Chevrolet Cruze body platform. Other OEM's, such as Toyota, an industry leader in producing hybrid vehicles, use a similar strategy for most of their hybrid vehicles, designing mainstream ICE platforms to accept larger battery packs, smaller gas tanks, downsized internal combustion engines and an electric drive motor. This allows the Phase 2 HD vehicle to be equipped with a standard ICE powertrain, a pure electric drive system or a hybrid powertrain. A similar vehicle would be Mercedes-Benz's S-Class, which is offered with powertrain options ranging from twin-turbo V-12s to a hybrid-electric setup with a plug-in hybrid concept being displayed at recent car shows.

4.5.8.9. Competitive Set Study

Lotus compiled data for a wide variety of vehicle classes – micro cars, small cars, midsize cars, large cars, small SUVs, midsize SUVs, large SUVs, compact pickup trucks, and small pickup trucks – as part of the development of the Phase 2 HD vehicle. This data provides the length, front and rear tracks, heights, wheelbases, weights, footprints, and specific densities of the major vehicle classes. This information is shown on Table 4.5.8.9.a below and a full list of vehicles with more detailed information can be found in Appendix B. Vehicle classes are listed in both EPA and EU classifications.

Table 4.5.8.9.a: Average vehicle class information

| Vehicle Class | Example Vehicle | Length (in.) | Front Track (in.) | Rear Track (in.) | Height (in.) | Wheelbase (in.) | Weight (lbs.) | Footprint (sq. ft.) | Specific Density (unitless) |
|---------------------------|-----------------|--------------|-------------------|------------------|--------------|-----------------|---------------|---------------------|-----------------------------|
| Mini car/ Subcompact | Toyota Yaris | 161.6 | 58.0 | 58.0 | 59.2 | 98.5 | 2550.0 | 39.69 | 1.46 |
| Small car/ Compact | Toyota Corolla | 176.0 | 59.9 | 60.0 | 58.3 | 103.9 | 2950.0 | 43.29 | 1.52 |
| Midsize car | Toyota Camry | 191.0 | 61.7 | 61.6 | 57.8 | 109.5 | 3320.0 | 46.89 | 1.63 |
| Large car | Toyota Avalon | 199.4 | 63.0 | 62.9 | 59.1 | 113.4 | 3860.0 | 49.59 | 1.73 |
| Small SUV | Toyota Rav4 | 174.4 | 61.5 | 61.6 | 66.8 | 103.3 | 3540.0 | 44.15 | 1.52 |
| Midsize SUV/ Crossover | Toyota Venza | 191.0 | 63.6 | 63.6 | 66.9 | 111.8 | 4320.0 | 49.37 | 1.61 |
| Fullsize SUV (BoF) | Toyota Sequoia | 202.8 | 66.7 | 67.4 | 74.2 | 117.7 | 5560.0 | 54.77 | 1.67 |
| Fullsize SUV (unibody) | Ford Flex | 201.5 | 66.3 | 66.3 | 69.0 | 118.5 | 4820.0 | 54.52 | 1.56 |
| Minivans | Toyota Sienna | 202.0 | 66.9 | 66.8 | 69.0 | 119.4 | 4440.0 | 55.38 | 1.45 |

The specific density in Table 4.5.8.9.a provides a direct comparison to the Phase 2 HD vehicle and demonstrates the potential for mass savings across each vehicle class. This is due to the definition of specific density, which is shown in Table 4.5.8.9.b below. This specific density shows just how much more mass there is per unit volume, giving an idea of the potential weight savings as shown in greater detail in section 4.5.8.10. Volumes of each vehicle were calculated using a shape factor as described by the equations in Table 4.5.8.9.b below as well as footprint and basic density calculations.

Table 4.5.8.9.b: Vehicle volume calculations based on shape factors

| Definitions | |
|---------------------------|--|
| Footprint = | $\text{Length} \times 0.5 \times (\text{Front Track} + \text{Rear Track})$ |
| Volume = | <i>Sedans:</i> $((\text{Wheelbase} \times \text{Height}) + ((\text{Length} - \text{Wheelbase}) \times 0.5 \times \text{Height})) \times \text{Width}$ |
| | <i>SUVs and Hatchbacks:</i> $((0.33 \times (\text{Length} - \text{Wheelbase}) \times \text{Height}) + (\text{Wheelbase} \times \text{Height}) + (0.67 \times (\text{Length} - \text{Wheelbase}) \times 0.5 \times \text{Height})) \times \text{Width}$ |
| | <i>Trucks:</i> $((\text{Bed Length} \times 0.5 \times \text{Height}) + (0.5 \times (\text{Length} - \text{Bed Length}) \times \text{Height}) + (0.5 \times (\text{Length} - \text{Bed Length}) \times 0.5 \times \text{Height})) \times \text{Width}$ |
| Density = | Weight/Volume |
| Specific Density = | Density/ARB Phase 2 Density |

4.5.8.10. Summary and Projected Weight Savings

The data presented in this section shows the scalability of the engineering and manufacturing techniques implemented to reduce vehicle weight. This section also includes– with one exception– an analysis indicating that automakers have been reducing vehicle weight, and a review of potential opportunities to further reduce vehicle mass at minimal cost. This is shown in the comparison between body-on-frame vehicles and unibody vehicles, as all of the body-on-frame vehicles, with the exception of the Honda Ridgeline, are heavier, and correspondingly denser than their unibody counterparts. The Ridgeline is an outlier as it's the only unibody pickup truck currently on sale and also offers significantly more standard content than unibody compact pickup trucks. Examples of the Ridgeline's added content are the full center console and adjustable front bucket seats; a simple bench seat layout (without a console) is standard on all other compact pickup trucks. Other, more luxurious features, some of which aren't available on other compact pickups, add to the weight and density of the Ridgeline. All of the vehicles shown were also base vehicles, which are typically two-door pickups while the Ridgeline is only available in a four-door version. More unibody, compact pickup trucks need to be available in order to further evaluate the use of a unibody structure in compact pickups, but the comparison of unibody and body-on-frame large SUVs shows the difference in structure. All fullsize pickup trucks currently utilize body-on-frame construction so a comparison between unibody and body-on-frame is not possible.

An objective means of measuring the potential weight savings for each vehicle class relative to the baseline Venza was created by developing a mathematical relationship based on relative specific densities and the mass reduction for the Phase 2 HD model vs. the baseline Venza. These values established the baseline figures and were used to create the following equation to quantify the potential relative weight savings:

$$PWS = \left(\frac{\text{Specific Density}}{1.62} \right) * 32.4$$

Where:
PWS = projected weight savings
Specific Density = vehicle density/Phase 2 HD total vehicle density
1.62 = baseline [Venza] specific density
32.4 = Phase 2 HD curb weight reduction as a percentage

Table 4.5.8.10.a below shows the potential weight savings across vehicle classes and also indicates that the 32.4-percent total vehicle weight savings will not scale directly across vehicle classes, particularly vehicles smaller than the Venza. Any vehicle with a PWS of less than 32.4 percent indicates that it has less mass savings potential than the Venza. Any vehicle with a PWS of greater than 32.4 percent indicates that it has more mass savings potential than the Venza. Smaller vehicles have less potential, e.g., the microcar has potential for a 28-percent weight savings. This analysis shows that a significant weight

savings can be achieved in every vehicle class by applying the methods and materials described in this study and in the Phase 1 report.

Table 4.5.8.10.a: Projected total vehicle weight savings by vehicle class

| Averages: | | | | | | |
|----------------------------|-------|----------|-------------------------------------|------|----------|---------------------------------|
| Density (lbs./ft3): | | ± | Specific Density (unitless): | | ± | Projected Weight Savings |
| Micro cars: | 7.91 | 0.00 | Micro cars: | 1.40 | 0.00 | 28.01% |
| Mini Cars: | 8.23 | 0.43 | Mini Cars: | 1.46 | 0.08 | 29.13% |
| Small Cars: | 8.61 | 0.53 | Small Cars: | 1.52 | 0.09 | 30.48% |
| Midsize Cars: | 9.19 | 0.24 | Midsize Cars: | 1.63 | 0.04 | 32.54% |
| Midsize Luxury Cars: | 10.17 | 0.28 | Midsize Luxury Cars: | 1.80 | 0.05 | 36.02% |
| Large Cars: | 9.75 | 0.38 | Large Cars: | 1.73 | 0.07 | 34.51% |
| Large Luxury Cars | 10.25 | 0.46 | Large Luxury Cars | 1.81 | 0.08 | 36.29% |
| Small SUVs: | 8.56 | 0.37 | Small SUVs: | 1.52 | 0.07 | 30.30% |
| Midsize SUVs: | 9.10 | 0.42 | Midsize SUVs: | 1.61 | 0.07 | 32.23% |
| Midsize Luxury SUVs: | 9.56 | 0.21 | Midsize Luxury SUVs: | 1.69 | 0.04 | 33.86% |
| Large BoF SUVs: | 9.46 | 0.18 | Large BoF SUVs: | 1.67 | 0.03 | 33.49% |
| Large Unibody SUVs: | 8.78 | 0.08 | Large Unibody SUVs: | 1.56 | 0.01 | 31.10% |
| Small BoF Pickups: | 10.03 | 0.49 | Small BoF Pickups: | 1.78 | 0.08 | 35.53% |
| Small Uni Pickups: | 10.37 | 0.00 | Small Uni Pickups: | 1.84 | 0.00 | 36.71% |
| Large Pickups: | 9.29 | 0.35 | Large Pickups: | 1.64 | 0.06 | 32.88% |
| Minivans: | 8.17 | 0.17 | Minivans: | 1.45 | 0.03 | 28.93% |

Based on the above analysis of the various vehicle dimensions and densities in a number of vehicle classes, the results of the Phase 2 HD design can be [roughly] scaled to other vehicle classes. Table 4.5.8.10.b below gives an estimation of how the mass and cost factors scale to other vehicle classes.

Table 4.5.8.10.b: Estimated mass and cost factors for various vehicle classes

| Vehicle Class | Example Vehicle | Original Vehicle Mass (kg) | Vehicle Mass Reduction | Projected Reduced Vehicle Mass (kg) | Original Body Mass (kg) | Body Mass Reduction | Projected Reduced Body Mass (kg) | Vehicle Cost Factor |
|---------------------------|------------------------|-----------------------------------|-------------------------------|--|--------------------------------|----------------------------|---|----------------------------|
| Mini car/ Subcompact | Toyota Yaris | 1113.5 | 29.1% | 789.1 | 228.0 | 36.9% | 143.9 | 131.5% |
| Small car/ Compact | Toyota Corolla | 1251.2 | 30.5% | 869.6 | 289.0 | 34.6% | 189.0 | 120.7% |
| Midsize car | Ford Fusion | 1555.4 | 32.5% | 1049.9 | 305.0 | 41.4% | 178.7 | 112.0% |
| Large car | Ford Taurus | 1803.7 | 34.5% | 1181.4 | 372.5 | 41.6% | 217.5 | 102.0% |
| Small SUV | Toyota Rav4 | 1632.7 | 30.3% | 1138.0 | 310.0 | 36.3% | 197.5 | 111.9% |
| Midsize SUV/ Crossover | Phase 2 HD | 1700.0 | 32.4% | 1150.0 | 382.5 | 38.5% | 260.8 | 106.0% |
| Large pickup (BoF) | Ford F-150 | 2406.4 | 32.9% | 1614.7 | 275.1 | 38.0% | 170.6 | 155.5% |
| Minivans | Toyota Sienna | 2091.0 | 28.9% | 1486.7 | 428.0 | 43.0% | 244.0 | 131.1% |

This information was compiled using the specific densities compiled in Table 4.5.8.10.a as well as the projected weight savings. A separate BIW specific density and projected weight savings were also calculated for every example vehicle in Table 4.5.8.10.b using the same formulas. This information was then used to project the reduced vehicle and reduced BIW

mass. The cost factor was determined by converting the known cost of the Phase 2 HD vehicle into a \$/kg figure and using the following formula:

$$CF = \frac{ReducedMass * Costperkg}{VehicleInvoice}$$

Where: CF = Cost Factor
Reduced Mass = Reduced Vehicle Mass
Cost per kg = Cost per kg for Phase 2 HD vehicle
Vehicle Invoice = Example Vehicle MSRP divided by RPE

4.6.1 Conclusions

This engineering study successfully achieved its objectives of developing and modeling the structure and crashworthiness of an over 30-percent mass-reduced vehicle through a holistic vehicle redesign. The Phase 2 vehicle design began with a 2009 Toyota Venza crossover vehicle and integrated relatively large quantities of advanced materials (e.g. aluminum, advanced high-strength steels, magnesium, and composites) and advanced designs and bonding techniques to achieve a substantial vehicular mass reduction. Vehicle body mass was reduced by 37 percent (141 kg) which contributed to a total vehicle mass reduction of 31 percent (527 kg) once the other vehicle systems (interior, suspension, closures, chassis, etc.) were optimized in a holistic redesign. Additionally, this mass reduction was achieved using a parallel-hybrid drivetrain; a lighter, non-hybrid drivetrain may reduce vehicle mass further while maintaining or improving performance relative to the baseline CUV.

This project uses emerging technologies, advanced materials, state-of-the-art manufacturing and bonding techniques, and innovative design to develop a low-mass model that has the potential to meet functional, crashworthiness, and structural integrity requirements for a passenger vehicle. The study developed a mass-reduced vehicle and evaluated it for body stiffness and crash performance relative to a variety of U.S. federal impact requirements and IIHS guidelines. This work indicates that a 30-percent lighter crossover vehicle has the potential to meet regulatory and consumer safety demands without compromising size, utility, or performance.

The mass-reduced design is found to result in a significant increase in the cost of the vehicle. The estimation of the direct manufacturing costs for the low mass vehicle body design suggests that the body structure itself would be 37 percent lighter (i.e. 141 kg) at a 60 percent plus cost (i.e. \$723) increase over the baseline vehicle body. When considering the comprehensive vehicle redesign including the body and non-body vehicle components, this vehicle design achieves a 32-percent mass reduction at a total direct incremental manufacturing cost decrease of around \$342 per vehicle because significant cost savings can be achieved from mass reductions in the interior, suspension, chassis,

interior, and closures areas. Therefore the study illustrates how a holistic, total vehicle approach to system mass and cost reductions can help offset the additional cost of a 37 percent mass reduced body structure. This study also estimates how these mass reductions and costs scale to other vehicle classes, finding that roughly similar mass-reduction and associated costs can be applied to other models ranging from subcompact cars to full-sized light trucks.

This study's findings also indicate that the 30-percent mass-reduced vehicle can be cost-effectively mass-produced in the 2020 timeframe with known materials and techniques. It is estimated with high confidence that the assembly and tooling costs of the new mass-reduced body design would have greatly reduced costs due to the substantial reduction in parts required, from 419 parts in the baseline Venza, to 169 parts in the low-mass design. By factoring in the manufacturability of the materials and designs into the fundamental design process, it is expected that, not only will this type of design be production-ready in 2020, but it also has the potential for wide commercialization in the 2025 timeframe.

4.6.2 Recommendations

A multi-material body structure should be built and tested to evaluate its structural characteristics for stiffness and modals (frequency response) using non-destructive testing methods.

Additionally, it is recommended that a low mass vehicle be constructed using the Lotus designed BIW, be fitted with components duplicating the non-body system masses and then be evaluated for FMVSS impact performance by NHTSA.

5. References

1. 2011 NHTSA Workshop on Vehicle Mass-Size-Safety, Ron Medford: http://www.nhtsa.gov/staticfiles/administration/pdf/presentations_speeches/Medford_Mass-Safety_Workshop_02252011.pdf
2. http://www.theicct.org/pubs/Mass_reduction_final_2010.pdf
3. <http://members.steel.org/AM/Template.cfm?Section=Home&TEMPLATE=/CM/ContentDisplay.cfm&CONTENTID=28272>
4. www.toyota.com/venza/specs.html
5. Alcan Press Release 09/06/2002
6. American Foundry Society: <http://www.afsinc.org/content/view/206>
7. SMW Forged Magnesium Wheels: <http://www.smw.com/contents/catalog/id/16>

6. List of Inventions Reported and Copyrighted Materials Produced

There were no inventions or copyrighted materials produced as a result of this contract.

7. Appendices

7.1. Appendix A: Manufacturing Report

Purpose of Study:

This study provides an overview about the characteristics of a Body Shop to build annually 60,000 bodies of the LWV (Light Weight Vehicle).

Due to the premature stage of the program we will not enter into the level of detail as typically done. In areas of uncertainty we will make assumptions and/or suggestions.

Jeff Wrobel

*Supervisor Process &
Simulation
EBZ Engineering, Inc.
110 South Blvd. W, Suite
100
Rochester Hills, MI
48307
(248) 299-0500*

March 1, 2011

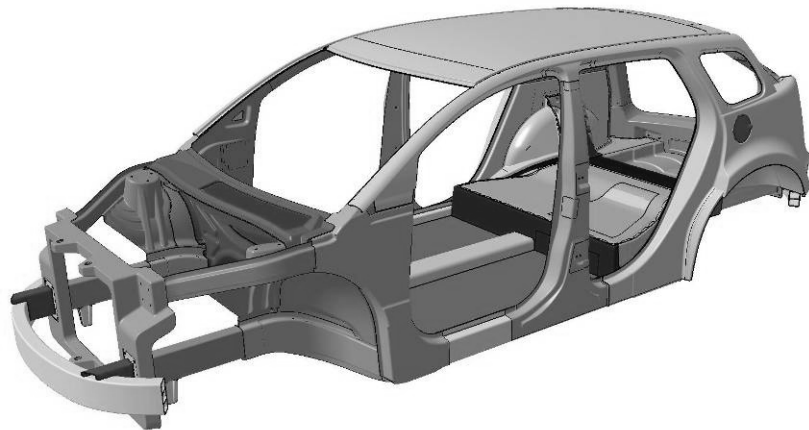

1.0 General Assumptions

- Two-shift operation
- Highly automated production system
- Single model, no derivatives
- New bonding technology, friction stir bonding (FSB)
- Materials: aluminum, magnesium, high strength steel, composites
- Only BIW considered in manufacturing study
- Cycle time is 191 seconds at 85-percent body shop efficiency
- Transportation time is 13 seconds (underbody line, framing line)
- Planned SOP: 2020

2.0 Process & Layout

2.1 Efficiencies

Three main factors drive assembly plant efficiency. These factors are the efficiency of workers and technical equipment, downtime in plant operation due to organizational problems, and other system related downtimes. Together, these factors account for the overall plant efficiency.

2.1.1 Equipment Efficiencies

These inefficiencies are relatively small but are always present and need to be accounted for. Workers are assumed to operate at 100% efficiency and technical equipment generally has an efficiency factor of 99% or higher. When all equipment efficiencies are combined in a complex manufacturing system of up to 20 connected stations, the efficiency factor drops to 95%.

2.1.2 Downtime due to Organizational Problems

There are downtimes inherent to any assembly plant. Organizational problems caused by logistics, environment, or political (strike) events account for part of these down times. Due to the unpredictable nature of these problems, the total reduction in efficiency varies and is more difficult to predict. Overall, they can account for a 5 – 90% reduction.

2.1.2 Overall System Related Downtime

Further downtimes occur due to overall system related downtime. Interaction between the different zones of the plant creates inefficiencies, which in turn reduces the total efficiency factor by an additional 5%.

Factoring in these three main contributions, the *total bodyshop efficiency* is 85%. This is illustrated below in Figure A.1.

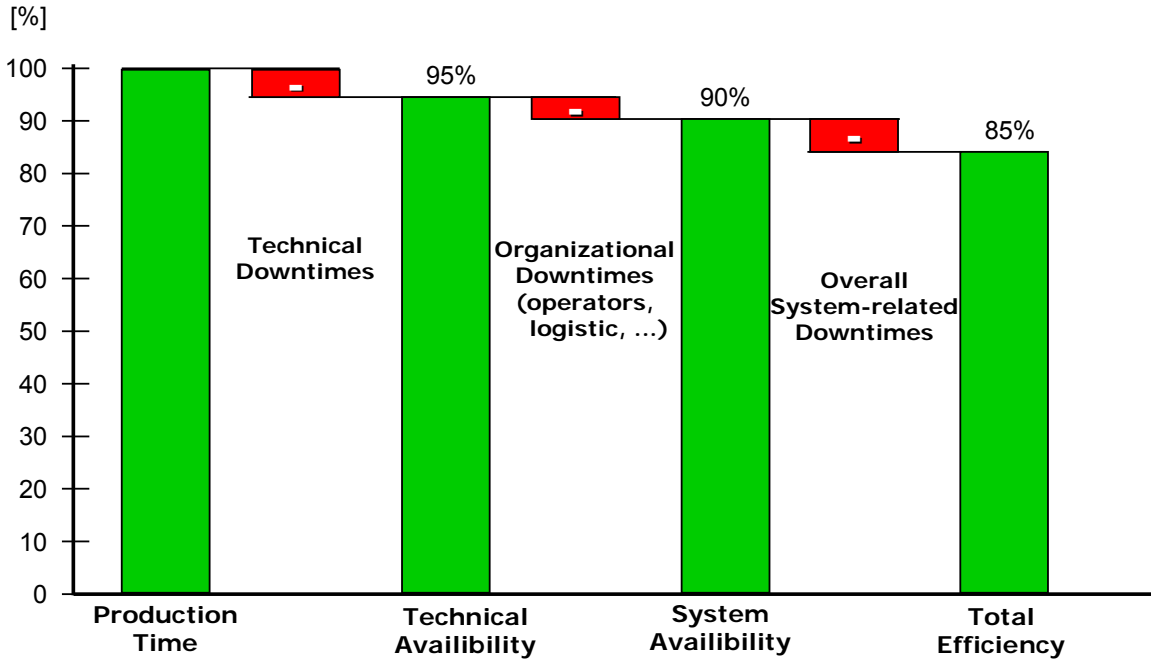

Figure A.1: Total efficiency

2.2 Assembly Sequence Per Station

The assembly sequence is broken up into 44 different stations on three lines – sub-assembly (SA), underbody assembly (UB), and framing line (FR). There are 19 sub-assembly stations, 14 underbody assembly stations, and 11 framing line assembly stations. This eases the assembly process, minimizes the area necessary for the final assembly line, and allows for sub-assemblies to be built elsewhere and shipped to the final assembly location, maximizing usable factory space.

Table 2.2.a below lists every assembly station by name and notes the function and parts involved.

Table 2.2.a: Assembly line stations, functions, and parts

| Station Name | Assembly Function | Parts Involved |
|--------------|--------------------------------|---|
| SA05 | Front and rear bumper assembly | Front and rear bumper brackets, mounting plates, beam |

| | | |
|---------|--|---|
| SA10 | Front frame rail assemblies | Frame rail mounting plates, rails, brackets, transitions, rocker extrusions |
| SA15 | L, R pillar sub-assemblies | A-pillar upper and lower, inner reinforcements; B-pillar upper and lower, inner and outers; roof rail, C-pillar striker reinforcement |
| SA20 | Rear end assembly | L, R shock towers and reinforcements |
| SA25 | X-member sub-assemblies | X-member extrusions, brackets, and reinforcements |
| SA30 | Complete floor X-member assembly | X-member sub-assemblies, crossbraces, reinforcements |
| SA35 | Rear end panel and compartment X-member assembly | Rear inner and outer panels, X-member extrusion and brackets |
| SA40 | Side rail assemblies | Rail and rocker extrusions, brackets, transitions, |
| SA45 | L, R rear wheelhouse assemblies | D-pillar inners, quarter panel inners, liftgate reinforcements, wheelhouse inners |
| SA50 | Dash sub-assembly | Dash panel, reinforcements |
| SA55 | Dash assembly | Dash sub-assembly, dash reinforcement, cowl panel support |
| SA60 | Rear seat assembly | Rear seat risers, floor reinforcements, floor panel |
| SA65 | L, R front wheelhouse assemblies | Front wheelhouse panels, shotguns, shock towers |
| SA70-10 | L, R roof, B-pillar bodyside inner assemblies | Front and rear roof side inners, upper and lower B-pillar inners |
| SA70-20 | L, R A-pillar outer assemblies | L, R A-pillar upper and lower outers, shotgun outers |
| SA70-30 | L, R C-pillar bodyside inner assemblies | L, R roof side rail sub-assembly, C-pillar outer upper |
| SA75 | L, R A-pillar inner sub-assemblies | L, R A-pillar upper and lower inners, A-pillar sub-assemblies |
| SA80 | L, R bodyside outer assembly | L, R rear quarter panel, tail lamp closeout, bodyside outer, bodyside outer frame rail, flange |
| SA85 | L, R inner B-Pillar assembly | L, R B-pillar sub-assembly, upper and lower inner reinforcements |
| UB100 | Initial underbody assembly | Floor crossmember, rear end, rear end panel, side rail assemblies |
| UB110 | Initial underbody assembly | Floor crossmember, rear end, rear end panel, side rail assemblies |
| UB120 | Rear wheelhouse and dash buildup | Previous underbody build, dash assembly, dash transmission reinforcements, rear wheelhouse assemblies |
| UB130 | Idle | |
| UB140 | Weld respotting | Previous underbody build |
| UB150 | Rear seat and A-pillar buildup | Previous underbody build, rear seat assembly, A-pillar assemblies |
| UB160 | Idle | |
| UB170 | Front wheelhouse buildup | Previous underbody build, front wheelhouse assemblies |
| UB180 | Central flooring | Previous underbody build, center floor panels |
| UB190 | Rear wheelhouse lining and rear rear flooring | Previous underbody build, rear wheelhouse outers, rear floor panel |
| UB200 | Weld respotting | Previous underbody build |
| UB210 | Stud application | Previous underbody build |
| UB220 | Camera inspection | Previous underbody build |
| UB230 | Elevator to framing | Previous underbody build |
| FR100 | Idle | |
| FR110 | Bodyside outer buildup | Underbody build, L,R bodyside inner assemblies |

| | | |
|-------|---------------------------------|--|
| FR120 | Weld respotting | Previous framing build |
| FR130 | Stud application | Previous framing build |
| FR140 | Bodyside inner buildup | Previous framing build, L, R bodyside outer assemblies |
| FR150 | Roof and cowl buildup | Previous framing build, cowl upper panel, roof panel, shotgun closeouts |
| FR160 | Weld respotting | Previous framing build |
| FR170 | Camera inspection | Previous framing build |
| FR180 | Bumper buildup | Previous framing build, front end module, front and rear bumper assemblies |
| FR190 | Surface finishing/reworking | Previous framing build |
| FR200 | Idle, electric motorized system | |

2.3 Timing Sheets Per Station

Cycle time was determined using the number of vehicles produced per year; the number of working days, shifts, and breaks per shift to determine total plant uptime; which was then used to determine a gross cycle time of 225 seconds. With an inefficiency of 15-percent, the net cycle time is 191 seconds. Table 2.3.a below shows the cycle time calculation.

Table 2.3.a: Net cycle time calculation

| | Item | Value | Formula |
|---|----------------------------------|------------|--|
| A | Vehicles/year | 60,000 | |
| B | Working days/year (365-104-11) | 250 | |
| C | Vehicles/day | 240 | A/B |
| D | Shifts | 2 | |
| E | Hours/shifts | 8 | |
| F | Break/shift | 0.5 | |
| G | Uptime/day (seconds/working day) | 54,000 | 7.5 hrs/shift *2 shifts/day *3600 s/hr |
| H | Gross cycle time (seconds) | 225 | G/C |
| I | Inefficiency factor | 15% | |
| J | Net Cycle Time | 191 | H*(1-I) |

Individual station timing sheets are listed below in Tables 2.3.b-2.3.ap. These timing sheets show the full assembly time necessary for each station and the timing of each step.

Table 2.3.c: Station SA10 timing sheet

| | Description | Walk (feet) | Queue (min) | FSJ | HEAT (min) | MIG (min) | start | time (sec) | | seconds |
|---|---|-------------|-------------|-----|------------|-----------|-------|------------|-------|---------|
| | | | | | | | | Az | sum | |
| Front Rail Assembly | | | | | | | | | | |
| CYCLE (BELOW) STARTS WITH A COMPLETED CYCLE | | | | | | | | | | |
| 1 | Operator walks to fixture SA10-30 | 4 | | | | | 0.0 | 1.2 | 1.2 | |
| 2 | Operator obtains 1st Front Rail Sub Assembly | | | | | | 1.2 | 1.8 | 3.0 | |
| 3 | Operator obtains 2nd Front Rail Sub Assembly | | | | | | 3.0 | 1.8 | 4.8 | |
| 4 | Operator walks to table | 4 | | | | | 4.8 | 1.2 | 6.0 | |
| 5 | Operator dispose of 1st Front Rail Sub Assembly onto table | | | | | | 6.0 | 1.5 | 7.5 | |
| 6 | Operator dispose of 2nd Front Rail Sub Assembly onto table | | | | | | 7.5 | 1.5 | 9.0 | |
| 7 | Operator walks to container for Flange | 2 | | | | | 9.0 | 0.6 | 9.6 | |
| 8 | Operator obtains 1st Flange | | | | | | 9.6 | 1.0 | 10.6 | |
| 9 | Operator obtains 2nd Flange | | | | | | 10.6 | 1.0 | 11.6 | |
| 10 | Operator walks to fixture SA10-30 | 4 | | | | | 11.6 | 1.2 | 12.8 | |
| 11 | Operator loads 1st Flange to fixture | | | | | | 12.8 | 1.2 | 14.0 | |
| 12 | Operator loads 2nd Flange to fixture | | | | | | 14.0 | 1.2 | 15.2 | |
| 13 | Operator walks to fixture SA10-20 | 2 | | | | | 15.2 | 0.6 | 15.8 | |
| 14 | Operator obtains 1st Front Rail Sub Assembly | | | | | | 15.8 | 1.2 | 17.0 | |
| 15 | Operator walks to fixture SA10-30 | 2 | | | | | 17.0 | 0.6 | 17.6 | |
| 16 | Operator loads 1st Front Rail Sub Assembly | | | | | | 17.6 | 1.8 | 19.4 | |
| 17 | Operator walks to fixture SA10-20 | 2 | | | | | 19.4 | 0.6 | 20.0 | |
| 18 | Operator obtains 2nd Front Rail Sub Assembly | | | | | | 20.0 | 1.2 | 21.2 | |
| 19 | Operator walks to fixture SA10-30 | 2 | | | | | 21.2 | 0.6 | 21.8 | |
| 20 | Operator loads 2nd Front Rail Sub Assembly | | | | | | 21.8 | 1.8 | 23.6 | |
| 21 | Operator walks to container for Front Rail | 7 | | | | | 23.6 | 2.1 | 25.7 | |
| 22 | Operator obtains 1st Front Rail | | | | | | 25.7 | 1.2 | 26.9 | |
| 23 | Operator obtains 2nd Front Rail | | | | | | 26.9 | 1.2 | 28.1 | |
| 24 | Operator walks to fixture SA10-20 | 7 | | | | | 28.1 | 2.1 | 30.2 | |
| 25 | Operator loads 1st Front Rail | | | | | | 30.2 | 1.8 | 32.0 | |
| 26 | Operator loads 2nd Front Rail | | | | | | 32.0 | 1.8 | 33.8 | |
| 27 | Operator walks to fixture SA10-10 | 2 | | | | | 33.8 | 0.6 | 34.4 | |
| 28 | Operator obtains 1st Mount Assembly | | | | | | 34.4 | 1.2 | 35.6 | |
| 29 | Operator obtains 2nd Mount Assembly | | | | | | 35.6 | 1.2 | 36.8 | |
| 30 | Operator walks to fixture SA10-10 | 2 | | | | | 36.8 | 0.6 | 37.4 | |
| 31 | Operator loads 1st Mount Assembly | | | | | | 37.4 | 1.5 | 38.9 | |
| 32 | Operator loads 2nd Mount Assembly | | | | | | 38.9 | 1.5 | 40.4 | |
| 33 | Operator walks to container for Front Rail Mount | 6 | | | | | 40.4 | 1.8 | 42.2 | |
| 34 | Operator obtains 1st Front Rail Mount | | | | | | 42.2 | 1.2 | 43.4 | |
| 35 | Operator obtains 2nd Front Rail Mount | | | | | | 43.4 | 1.2 | 44.6 | |
| 36 | Operator walks to fixture SA10-10 | 5 | | | | | 44.6 | 1.5 | 46.1 | |
| 37 | Operator loads 1st Front Rail Mount | | | | | | 46.1 | 1.5 | 47.6 | |
| 38 | Operator loads 2nd Front Rail Mount | | | | | | 47.6 | 1.5 | 49.1 | |
| 39 | Operator walks to container for Front Mount Cover | 5 | | | | | 49.1 | 1.5 | 50.6 | |
| 40 | Operator obtains 1st Front Mount Cover | | | | | | 50.6 | 1.0 | 51.6 | |
| 41 | Operator obtains 2nd Front Mount Cover | | | | | | 51.6 | 1.0 | 52.6 | |
| 42 | Operator walks to fixture SA10-10 | 5 | | | | | 52.6 | 1.5 | 54.1 | |
| 43 | Operator loads 1st Front Mount Cover | | | | | | 54.1 | 1.5 | 55.6 | |
| 44 | Operator loads 2nd Front Mount Cover | | | | | | 55.6 | 1.5 | 57.1 | |
| 45 | Operator walks to container for Front Mount Cover | 5 | | | | | 57.1 | 1.5 | 58.6 | |
| 46 | Operator obtains 3rd Front Mount Cover | | | | | | 58.6 | 1.0 | 59.6 | |
| 47 | Operator obtains 4th Front Mount Cover | | | | | | 59.6 | 1.0 | 60.6 | |
| 48 | Operator walks to fixture SA10-10 | 5 | | | | | 60.6 | 1.5 | 62.1 | |
| 49 | Operator loads 3rd Front Mount Cover | | | | | | 62.1 | 1.5 | 63.6 | |
| 50 | Operator loads 4th Front Mount Cover | | | | | | 63.6 | 1.5 | 65.1 | |
| 51 | Operator walks to palm buttons | 7 | | | | | 65.1 | 2.1 | 67.2 | |
| 52 | Operator depress palm buttons | | | | | | 67.2 | 1.0 | 68.2 | |
| 53 | SA10 operator side Safety Door closes | | | | | | 68.2 | 3.0 | 71.2 | |
| 54 | Robot SA10R10 rotates to fixture SA10-30 | | | | | | 71.2 | 1.5 | 72.7 | |
| 55 | Robot SA10R10 welds 4 beads on 1st Front Rail pieces (58.2, 58.2, 32.5, 32.5) 11mm per second | | | | 181.5 | | 72.7 | 16.5 | 89.2 | |
| 56 | Robot SA10R10 welds 4 beads on 2nd Front Rail pieces (58.2, 58.2, 32.5, 32.5) 11mm per second | | | | 181.5 | | 89.2 | 16.5 | 105.7 | |
| 57 | Robot SA10R10 rotates to fixture SA10-20 | | | | | | 105.7 | 1.5 | 107.2 | |
| 58 | Robot SA10R10 welds 2 beads on 2nd Front Rail pieces (32.5, 32.5) 11mm per second | | | | 65.0 | | 107.2 | 5.9 | 113.1 | |
| 59 | Robot SA10R10 welds 2 beads on 1st Front Rail pieces (32.5, 32.5) 11mm per second | | | | 65.0 | | 113.1 | 5.9 | 119.0 | |
| 60 | Robot SA10R10 rotates to fixture SA10-10 | | | | | | 119.0 | 1.5 | 120.5 | |
| 61 | Robot SA10R10 welds 4 beads on 1st Front Mount Cover (90.0, 90.0, 90.0, 90.0) 11mm per second | | | | 360.0 | | 120.5 | 32.7 | 153.2 | |
| 62 | Robot SA10R10 welds 4 beads on 2nd Front Mount Cover (90.0, 90.0, 90.0, 90.0) 11mm per second | | | | 360.0 | | 153.2 | 32.7 | 186.0 | |
| 63 | Robot SA05R10 rotates to clear SA05-20 | | | | | | 186.0 | 1.5 | 187.5 | |
| 64 | SA10 operator side safety door opens | | | | | | 187.5 | 3.0 | 190.5 | |
| 65 | Operator walks to table | 1 | | | | | 190.5 | 0.3 | 190.8 | |
| 66 | Operator obtains 1st Front Rail Sub Assembly | | | | | | 190.8 | 1.8 | 192.6 | |
| 67 | Operator obtains 2nd Front Rail Sub Assembly | | | | | | 192.6 | 1.8 | 194.4 | |
| 68 | Operator walks to container for 1st Front Rail Sub Assembly | 8 | | | | | 194.4 | 2.4 | 196.8 | |
| 69 | Operator dispose of 1st Front Rail Sub Assembly to container | | | | | | 196.8 | 1.8 | 198.6 | |
| 70 | Operator walks to container for 2nd Front Rail Sub Assembly | 4 | | | | | 198.6 | 1.2 | 199.8 | |
| 71 | Operator dispose of 2nd Front Rail Sub Assembly to container | | | | | | 199.8 | 1.8 | 201.6 | |
| 72 | Operator walks to | 8 | | | | | 201.6 | 2.4 | 204.0 | |
| Station Cycle Time | | | | | | | | | 191.0 | 191.0 |
| Walk Summary (linear feet) | | 99 | | | | | | | | |
| Glue Summary (linear mm) | | | 0 | | | | | | | |
| Friction Stir Summary | | | | 0 | | | | | | |
| Hem Summary (linear mm) | | | | | 0 | | | | | |
| MIG Summary (linear mm) | | | | | | 1213 | | | | |

Table 2.3.d: Station SA15 timing sheet

| Line | Description | Walk (feet) | Glue (mm) | Rivet | Hem (mm) | MG (mm) | Start | Time (sec) | | seconds |
|---|---|-------------|-----------|-------|----------|---------|-------|------------|--------------|--------------|
| | | | | | | | | Actual | Sum | |
| Self Pierce Rivets – Aluminum to High Strength Steel | | | | | | | | | | |
| <i>CYCLE (BELOW STARTS WITH A COMPLETED CYCLE)</i> | | | | | | | | | | |
| 1 | Operator walks to fixture SA15-10 | 6 | | | | | 0.0 | 1.8 | 1.8 | |
| 2 | Operator obtains Reinf. A-Pillar Upper | | | | | | 1.8 | 1.2 | 3.0 | |
| 3 | Operator obtains Reinf. A-Pillar Lower | | | | | | 3.0 | 1.2 | 4.2 | |
| 4 | Operator walks to container A-Pillar Upper | 6 | | | | | 4.2 | 1.8 | 6.0 | |
| 5 | Operator dispose of A-Pillar Upper | | | | | | 6.0 | 1.0 | 7.0 | |
| 6 | Operator dispose of A-Pillar Lower | | | | | | 7.0 | 1.0 | 8.0 | |
| 7 | Operator obtains Upper Hinge Plate | | | | | | 8.0 | 1.0 | 9.0 | |
| 8 | Operator obtains Lower Hinge Plate | | | | | | 9.0 | 1.0 | 10.0 | |
| 9 | Operator walks to fixture SA15-10 | 6 | | | | | 10.0 | 1.8 | 11.8 | |
| 10 | Operator loads Upper Hinge Plate | | | | | | 11.8 | 1.2 | 13.0 | |
| 11 | Operator loads Lower Hinge Plate | | | | | | 13.0 | 1.2 | 14.2 | |
| 12 | Operator obtains B-Pillar Inner | | | | | | 14.2 | 2.0 | 16.2 | |
| 13 | Operator walks to container B-Pillar Inner | 6 | | | | | 16.2 | 1.8 | 18.0 | |
| 14 | Operator dispose of B-Pillar Inner | | | | | | 18.0 | 1.8 | 19.8 | |
| 15 | Operator obtains B-Pillar Upper Inner | | | | | | 19.8 | 1.5 | 21.3 | |
| 16 | Operator walks to fixture SA15-10 | 6 | | | | | 21.3 | 2.4 | 23.7 | |
| 17 | Operator loads B-Pillar Upper Inner | | | | | | 23.7 | 1.8 | 25.5 | |
| 18 | Operator walks to container B-Pillar Inner | 6 | | | | | 25.5 | 2.4 | 27.9 | |
| 19 | Operator obtains B-Pillar Inner | | | | | | 27.9 | 1.8 | 29.7 | |
| 20 | Operator walks to fixture SA15-10 | 6 | | | | | 29.7 | 2.4 | 32.1 | |
| 21 | Operator loads B-Pillar Inner | | | | | | 32.1 | 2.4 | 34.5 | |
| 22 | Operator obtains B-Pillar Outer | | | | | | 34.5 | 2.0 | 36.5 | |
| 23 | Operator walks to container B-Pillar Outer | 6 | | | | | 36.5 | 1.8 | 38.3 | |
| 24 | Operator dispose of B-Pillar Outer | | | | | | 38.3 | 1.8 | 40.1 | |
| 25 | Operator obtains B-Pillar Outer | | | | | | 40.1 | 1.8 | 41.9 | |
| 26 | Operator walks to fixture SA15-10 | 6 | | | | | 41.9 | 1.8 | 43.7 | |
| 27 | Operator loads B-Pillar Outer | | | | | | 43.7 | 2.4 | 46.1 | |
| 28 | Operator obtains C-Pillar Assembly | | | | | | 46.1 | 2.4 | 48.5 | |
| 29 | Operator walks to container C-Pillar Assembly | 6 | | | | | 48.5 | 2.4 | 50.9 | |
| 30 | Operator dispose of C-Pillar Assembly | | | | | | 50.9 | 2.2 | 53.1 | |
| 31 | Operator walks to container C-Pillar Latch | 2 | | | | | 53.1 | 0.6 | 53.7 | |
| 32 | Operator obtains C-Pillar Latch | | | | | | 53.7 | 1.2 | 54.9 | |
| 33 | Operator walks to container B-Pillar Upper Outer | 2 | | | | | 54.9 | 0.6 | 55.5 | |
| 34 | Operator obtains B-Pillar Upper Outer | | | | | | 55.5 | 1.2 | 56.7 | |
| 35 | Operator walks to fixture SA15-10 | 6 | | | | | 56.7 | 2.4 | 59.1 | |
| 36 | Operator loads C-Pillar Latch | | | | | | 59.1 | 1.5 | 60.6 | |
| 37 | Operator loads B-Pillar Upper Outer | | | | | | 60.6 | 1.8 | 62.4 | |
| 38 | Operator walks to container C-Pillar | 6 | | | | | 62.4 | 2.4 | 64.8 | |
| 39 | Operator obtains C-Pillar | | | | | | 64.8 | 2.4 | 67.2 | |
| 40 | Operator walks to fixture SA15-10 | 6 | | | | | 67.2 | 2.4 | 69.6 | |
| 41 | Operator loads C-Pillar | | | | | | 69.6 | 3.0 | 72.6 | |
| 42 | Operator walks to container A-Pillar Upper | 6 | | | | | 72.6 | 1.8 | 74.4 | |
| 43 | Operator obtains A-Pillar Upper | | | | | | 74.4 | 1.0 | 75.4 | |
| 44 | Operator walks to container A-Pillar Lower | 2 | | | | | 75.4 | 0.6 | 76.0 | |
| 45 | Operator obtains A-Pillar Lower | | | | | | 76.0 | 1.0 | 77.0 | |
| 46 | Operator walks to fixture SA15-10 | 6 | | | | | 77.0 | 2.4 | 79.4 | |
| 47 | Operator loads A-Pillar Lower | | | | | | 79.4 | 1.2 | 80.6 | |
| 48 | Operator obtains A-Pillar Upper | | | | | | 80.6 | 1.2 | 81.8 | |
| 49 | Operator walks to palm buttons | 5 | | | | | 81.8 | 1.5 | 83.3 | |
| 50 | Operator depress palm buttons | | | | | | 83.3 | 1.0 | 84.3 | |
| 51 | Fixture rotates 180° | | | | | | 84.3 | 1.5 | 85.8 | |
| 52 | Robot SA15R10 rotates from clear | | | | | | 85.8 | 1.5 | 87.3 | |
| 53 | Robot SA15R10 apply adhesive to Upper Hinge Plate 274.4mm @ 200mm per sec. | 274.4 | | | | | 87.3 | 1.4 | 88.7 | |
| 54 | Robot SA15R10 apply adhesive to Lower Hinge Plate 274.4mm @ 200mm per sec. | 274.4 | | | | | 88.7 | 2.0 | 90.7 | |
| 55 | Robot SA15R10 rotates to B-Pillar Inner | | | | | | 90.7 | 0.9 | 91.6 | |
| 56 | Robot SA15R10 apply adhesive to B-Pillar Inner 187.5mm @ 200mm per sec. | 187.5 | | | | | 91.6 | 1.5 | 93.1 | |
| 57 | Robot SA15R10 rotates to B-Pillar Outer | | | | | | 93.1 | 2.4 | 95.5 | |
| 58 | Robot SA15R10 apply adhesive to B-Pillar Outer 472.0mm @ 200mm per sec. | 472.0 | | | | | 95.5 | 0.8 | 96.3 | |
| 59 | Robot SA15R10 rotates to B-Pillar Outer | | | | | | 96.3 | 1.0 | 97.3 | |
| 60 | Robot SA15R10 apply adhesive to B-Pillar Outer 193.3mm @ 200mm per sec. | 193.3 | | | | | 97.3 | 1.5 | 98.8 | |
| 61 | Robot SA15R10 apply adhesive to B-Pillar Outer 309.6mm @ 200mm per sec. | 309.6 | | | | | 98.8 | 1.5 | 100.3 | |
| 62 | Robot SA15R10 rotates to C-Pillar Latch | | | | | | 100.3 | 1.0 | 101.3 | |
| 63 | Robot SA15R10 apply adhesive to C-Pillar Latch 200.0mm @ 200mm per sec. | 200.0 | | | | | 101.3 | 1.5 | 102.8 | |
| 64 | Robot SA15R10 rotates to clear | | | | | | 102.8 | 3.0 | 105.8 | |
| 65 | Pne loader index Reinf A-Pillar Upper | | | | | | 105.8 | 3.0 | 108.8 | |
| 66 | Pne loader index Reinf A-Pillar Lower | | | | | | 108.8 | 3.0 | 111.8 | |
| 67 | Pne loader index B-Pillar Inner Upper | | | | | | 111.8 | 3.0 | 114.8 | |
| 68 | Pne loader index B-Pillar Outer Upper | | | | | | 114.8 | 4.0 | 118.8 | |
| 69 | Pne loader index Latch Reinf | | | | | | 118.8 | 1.0 | 119.8 | |
| 70 | Fixture clamp close | | | | | | 119.8 | 1.0 | 120.8 | |
| 71 | Robot SA15R20 rotates from clear | | | | | | 120.8 | 1.5 | 122.3 | |
| 72 | Robot SA15R20 apply 4 self piercing rivets to Upper Hinge Plate | 4 | | | | | 122.3 | 12.0 | 134.3 | |
| 73 | Robot SA15R20 repositions | | | | | | 134.3 | 1.5 | 135.8 | |
| 74 | Robot SA15R20 apply 4 self piercing rivets to Lower Hinge Plate | 4 | | | | | 135.8 | 12.0 | 147.8 | |
| 75 | Robot SA15R20 repositions | | | | | | 147.8 | 1.5 | 149.3 | |
| 76 | Robot SA15R20 apply 5 self piercing rivets to B-Pillar Inner | 5 | | | | | 149.3 | 15.0 | 164.3 | |
| 77 | Robot SA15R20 repositions | | | | | | 164.3 | 1.5 | 165.8 | |
| 78 | Robot SA15R20 apply 5 self piercing rivets to B-Pillar Outer | 5 | | | | | 165.8 | 15.0 | 180.8 | |
| 79 | Robot SA15R20 repositions | | | | | | 180.8 | 1.5 | 182.3 | |
| 80 | Robot SA15R20 apply 5 self piercing rivets to C-Pillar | 5 | | | | | 182.3 | 15.0 | 197.3 | |
| 81 | Robot SA15R20 rotates to clear | | | | | | 197.3 | 1.5 | 198.8 | |
| Station Cycle Time | | | | | | | | | 191.0 | 191.0 |
| Walk Summary (linear feet) | | 117 | | | | | | | | |
| Glue Summary (linear mm) | | | 2075 | | | | | | | |
| Self Piercing Rivet Summary | | | | 23 | | | | | | |
| Hem Summary (linear mm) | | | | | 0 | | | | | |
| MG Summary (linear mm) | | | | | | 0 | | | | |

Table 2.3.e: Station SA20 timing sheet

| | Description | Walk (feet) | Glue (mm) | FSJ | RIVTAC | MIG (mm) | start | | time (sec) | | seconds | | | | | | | | | | | | | | | | | | | | | | | | | | | | | | | | | | | | |
|--|--|-------------|-----------|-----|--------|----------|-------|------|------------|-------|---------|----|----|----|----|----|----|----|----|----|----|----|----|----|----|----|----|----|-----|-----|-----|-----|-----|-----|-----|-----|-----|-----|-----|-----|-----|-----|-----|-----|-----|-----|-----|
| | | | | | | | | Az | sum | 5 | 10 | 15 | 20 | 25 | 30 | 35 | 40 | 45 | 50 | 55 | 60 | 65 | 70 | 75 | 80 | 85 | 90 | 95 | 100 | 105 | 110 | 115 | 120 | 125 | 130 | 135 | 140 | 145 | 150 | 155 | 160 | 165 | 170 | 175 | 180 | 185 | 190 |
| | | | | | | | | | | | | | | | | | | | | | | | | | | | | | | | | | | | | | | | | | | | | | | | |
| <i>Cycle (below) starts with a completed cycle</i> | | | | | | | | | | | | | | | | | | | | | | | | | | | | | | | | | | | | | | | | | | | | | | | |
| 1 | Operator unloads Rear Compartment XMbr Asm to bin | | | | | | 0.0 | 8.0 | 8.0 | | | | | | | | | | | | | | | | | | | | | | | | | | | | | | | | | | | | | | |
| 2 | Operator loads (3) parts to staging fixture | | | | | | 8.0 | 18.0 | 26.0 | | | | | | | | | | | | | | | | | | | | | | | | | | | | | | | | | | | | | | |
| 3 | Operator loads XMbr to GEO fixture | | | | | | 26.0 | 6.0 | 32.0 | | | | | | | | | | | | | | | | | | | | | | | | | | | | | | | | | | | | | | |
| 4 | Operator depress palm button | | | | | | 32.0 | 1.5 | 33.5 | | | | | | | | | | | | | | | | | | | | | | | | | | | | | | | | | | | | | | |
| 5 | Robot SA20R10 unloads (3) parts from staging fixture | | | | | | 33.5 | 18.0 | 51.5 | | | | | | | | | | | | | | | | | | | | | | | | | | | | | | | | | | | | | | |
| 6 | Robot SA20R10 applies PED adhesive to (3) parts | | 2715 | | | | 51.5 | 18.6 | 70.1 | | | | | | | | | | | | | | | | | | | | | | | | | | | | | | | | | | | | | | |
| 7 | Robot SA20R10 loads (3) parts to GEO fixture | | | | | | 70.1 | 18.0 | 88.1 | | | | | | | | | | | | | | | | | | | | | | | | | | | | | | | | | | | | | | |
| 8 | Robot SA20R10 changes Gripper to RivTac Gun | | | | | | 88.1 | 15.0 | 103.1 | | | | | | | | | | | | | | | | | | | | | | | | | | | | | | | | | | | | | | |
| 9 | Robot SA20R10 Rivtac (28 spots) | | | | 28 | | 103.1 | 56.0 | 159.1 | | | | | | | | | | | | | | | | | | | | | | | | | | | | | | | | | | | | | | |
| 10 | Robot SA20R10 changes Rivtac Gun to Gripper | | | | | | 159.1 | 15.0 | 174.1 | | | | | | | | | | | | | | | | | | | | | | | | | | | | | | | | | | | | | | |
| Station Cycle Time | | | | | | | | | 191.0 | 191.0 | | | | | | | | | | | | | | | | | | | | | | | | | | | | | | | | | | | | | |
| Walk Summary (linear feet) | | 0 | | | | | | | | | | | | | | | | | | | | | | | | | | | | | | | | | | | | | | | | | | | | | |
| Glue Summary (linear mm) | | 2715 | | | | | | | | | | | | | | | | | | | | | | | | | | | | | | | | | | | | | | | | | | | | | |
| Friction Stir Summary | | | 0 | | | | | | | | | | | | | | | | | | | | | | | | | | | | | | | | | | | | | | | | | | | | |
| RIVTAC Summary | | | | 28 | | | | | | | | | | | | | | | | | | | | | | | | | | | | | | | | | | | | | | | | | | | |
| MIG Summary (linear mm) | | | | | 0 | | | | | | | | | | | | | | | | | | | | | | | | | | | | | | | | | | | | | | | | | | |

Table 2.3.f: Station SA25 timing sheet

| | Description | Walk (feet) | Glue (mm) | FSJ | RIVTAC | MIG (mm) | start | | time (sec) | | seconds | | | | | | | | | | | | | | | | | | | | | | | | | | | | | | | | | | | | |
|--|--|-------------|-----------|-----|--------|----------|-------|------|------------|-------|---------|----|----|----|----|----|----|----|----|----|----|----|----|----|----|----|----|----|-----|-----|-----|-----|-----|-----|-----|-----|-----|-----|-----|-----|-----|-----|-----|-----|-----|-----|-----|
| | | | | | | | | Az | sum | 5 | 10 | 15 | 20 | 25 | 30 | 35 | 40 | 45 | 50 | 55 | 60 | 65 | 70 | 75 | 80 | 85 | 90 | 95 | 100 | 105 | 110 | 115 | 120 | 125 | 130 | 135 | 140 | 145 | 150 | 155 | 160 | 165 | 170 | 175 | 180 | 185 | 190 |
| | | | | | | | | | | | | | | | | | | | | | | | | | | | | | | | | | | | | | | | | | | | | | | | |
| <i>Cycle (below) starts with a completed cycle</i> | | | | | | | | | | | | | | | | | | | | | | | | | | | | | | | | | | | | | | | | | | | | | | | |
| 1 | Operator loads (2) "T" Rails to Station SA25-10 | | | | | | 0.0 | 10.0 | 10.0 | | | | | | | | | | | | | | | | | | | | | | | | | | | | | | | | | | | | | | |
| 2 | Operator loads Extrusion and XMbr to Sta SA25-10 (8 times) | | | | | | 10.0 | 72.0 | 82.0 | | | | | | | | | | | | | | | | | | | | | | | | | | | | | | | | | | | | | | |
| 3 | Operator depress palm buttons | | | | | | 82.0 | 1.5 | 83.5 | | | | | | | | | | | | | | | | | | | | | | | | | | | | | | | | | | | | | | |
| 4 | Tool Closes (Sta SA25-10) | | | | | | 83.5 | 3.0 | 86.5 | | | | | | | | | | | | | | | | | | | | | | | | | | | | | | | | | | | | | | |
| 4 | Operator loads (8) nuts and bolts | | | | | | 83.5 | 64.0 | 147.5 | | | | | | | | | | | | | | | | | | | | | | | | | | | | | | | | | | | | | | |
| 5 | Operator obtains Nut Runner and Runs (8) Nuts | | | | | | 147.5 | 23.0 | 170.5 | | | | | | | | | | | | | | | | | | | | | | | | | | | | | | | | | | | | | | |
| 6 | Operator loads (6) parts to Sta SA25-20 | | | | | | 170.5 | 20.0 | 190.5 | | | | | | | | | | | | | | | | | | | | | | | | | | | | | | | | | | | | | | |
| 7 | Robot SA25R20 loads XMbr Sub Asm to Sta SA25-20 | | | | | | 0.0 | 8.0 | 8.0 | | | | | | | | | | | | | | | | | | | | | | | | | | | | | | | | | | | | | | |
| 8 | Robot SA25R20 changes Gripper to Friction Stir Unit | | | | | | 8.0 | 15.0 | 23.0 | | | | | | | | | | | | | | | | | | | | | | | | | | | | | | | | | | | | | | |
| 9 | Robot SA25R20 FSJ (22 spots) in Sta SA25-20 | | | 22 | | | 23.0 | 66.0 | 89.0 | | | | | | | | | | | | | | | | | | | | | | | | | | | | | | | | | | | | | | |
| 10 | Robot SA25R20 FSJ (16 spots) in Sta SA25-10 | | | 16 | | | 89.0 | 52.0 | 141.0 | | | | | | | | | | | | | | | | | | | | | | | | | | | | | | | | | | | | | | |
| 11 | Robot SA25R20 changes FSJ to Gripper | | | | | | 141.0 | 15.0 | 156.0 | | | | | | | | | | | | | | | | | | | | | | | | | | | | | | | | | | | | | | |
| 12 | Robot SA25R20 unloads XMbr Sub Asm | | | | | | 173.0 | 10.0 | 183.0 | | | | | | | | | | | | | | | | | | | | | | | | | | | | | | | | | | | | | | |
| 13 | Robot SA25R10 Rivtac (16 spots) | | | | 16 | | 141.0 | 32.0 | 173.0 | | | | | | | | | | | | | | | | | | | | | | | | | | | | | | | | | | | | | | |
| 14 | Tool Opens | | | | | | 183.0 | 2.0 | 185.0 | | | | | | | | | | | | | | | | | | | | | | | | | | | | | | | | | | | | | | |
| Station Cycle Time | | | | | | | | | 191.0 | 191.0 | | | | | | | | | | | | | | | | | | | | | | | | | | | | | | | | | | | | | |
| Walk Summary (linear feet) | | 0 | | | | | | | | | | | | | | | | | | | | | | | | | | | | | | | | | | | | | | | | | | | | | |
| Glue Summary (linear mm) | | | 0 | | | | | | | | | | | | | | | | | | | | | | | | | | | | | | | | | | | | | | | | | | | | |
| Friction Stir Summary | | | | 38 | | | | | | | | | | | | | | | | | | | | | | | | | | | | | | | | | | | | | | | | | | | |
| RIVTAC Summary | | | | | 16 | | | | | | | | | | | | | | | | | | | | | | | | | | | | | | | | | | | | | | | | | | |
| MIG Summary (linear mm) | | | | | 0 | | | | | | | | | | | | | | | | | | | | | | | | | | | | | | | | | | | | | | | | | | |

Table 2.3.i: Station SA60 timing sheet

| | Description | Walk (feet) | Glue (mm) | FSJ | HEM (mm) | MIG (mm) | start | time (sec) | | seconds | | | | | | | | | | | | | | | | | | | | | | | | | | | | | |
|--|---|-------------|-----------|-----|----------|----------|-------|------------|-------|---|----|----|----|----|----|----|----|----|----|----|----|----|----|----|----|----|----|----|-----|-----|-----|-----|-----|-----|-----|-----|-----|-----|-----|
| | | | | | | | | Az. | sum | 5 | 10 | 15 | 20 | 25 | 30 | 35 | 40 | 45 | 50 | 55 | 60 | 65 | 70 | 75 | 80 | 85 | 90 | 95 | 100 | 105 | 110 | 115 | 120 | 125 | 130 | 135 | 140 | 145 | 150 |
| Rear Seat Asm | | | | | | | | | | | | | | | | | | | | | | | | | | | | | | | | | | | | | | | |
| <i>CYCLE (BELOW) STARTS WITH A COMPLETED CYCLE</i> | | | | | | | | | | | | | | | | | | | | | | | | | | | | | | | | | | | | | | | |
| 1 | Operator loads (3) parts to Stage 1 | | | | | | 0.0 | 15.0 | 15.0 | [Bar chart showing activity from 0 to 15s] | | | | | | | | | | | | | | | | | | | | | | | | | | | | | |
| 2 | Operator depress palm button | | | | | | 15.0 | 1.5 | 16.5 | [Bar chart showing activity from 15 to 16.5s] | | | | | | | | | | | | | | | | | | | | | | | | | | | | | |
| 3 | Operator loads (3) parts to Stage 2 | | | | | | 16.5 | 15.0 | 31.5 | [Bar chart showing activity from 16.5 to 31.5s] | | | | | | | | | | | | | | | | | | | | | | | | | | | | | |
| 4 | Operator depress palm button | | | | | | 31.5 | 1.5 | 33.0 | [Bar chart showing activity from 31.5 to 33s] | | | | | | | | | | | | | | | | | | | | | | | | | | | | | |
| 5 | Robot SA60R10 unloads (1) part and applies ped adhesive | 240 | | | | | 16.5 | 10.0 | 26.5 | [Bar chart showing activity from 16.5 to 26.5s] | | | | | | | | | | | | | | | | | | | | | | | | | | | | | |
| 6 | Robot SA60R10 loads (1) part to Stage 1 | | | | | | 26.5 | 6.0 | 32.5 | [Bar chart showing activity from 26.5 to 32.5s] | | | | | | | | | | | | | | | | | | | | | | | | | | | | | |
| 7 | Tool Closes | | | | | | 32.5 | 3.0 | 35.5 | [Bar chart showing activity from 32.5 to 35.5s] | | | | | | | | | | | | | | | | | | | | | | | | | | | | | |
| 8 | Robot SA60R10 changes gripper to FSJ gun | | | | | | 32.5 | 15.0 | 47.5 | [Bar chart showing activity from 32.5 to 47.5s] | | | | | | | | | | | | | | | | | | | | | | | | | | | | | |
| 9 | Robot SA60R10 FSJ Rear Seat Risers in Stage 1 | | | 6 | | | 47.5 | 18.0 | 65.5 | [Bar chart showing activity from 47.5 to 65.5s] | | | | | | | | | | | | | | | | | | | | | | | | | | | | | |
| 10 | Robot SA60R10 FSJ Rear Seat Asm in Stage 2 | | | 29 | | | 65.5 | 87.0 | 152.5 | [Bar chart showing activity from 65.5 to 152.5s] | | | | | | | | | | | | | | | | | | | | | | | | | | | | | |
| 11 | Robot SA60R10 changes FSJ gun to Gripper | | | | | | 152.5 | 15.0 | 167.5 | [Bar chart showing activity from 152.5 to 167.5s] | | | | | | | | | | | | | | | | | | | | | | | | | | | | | |
| 12 | Robot SA60R10 loads Riser Rear Seat to Stage 2 | | | | | | 167.5 | 12.0 | 179.5 | [Bar chart showing activity from 167.5 to 179.5s] | | | | | | | | | | | | | | | | | | | | | | | | | | | | | |
| 13 | Robot SA60R20 unloads (1) part and applies ped adhesive | 2475 | | | | | 33.0 | 20.0 | 53.0 | [Bar chart showing activity from 33 to 53s] | | | | | | | | | | | | | | | | | | | | | | | | | | | | | |
| 14 | Robot SA60R20 loads (1) part to Stage 2 | | | | | | 53.0 | 6.0 | 59.0 | [Bar chart showing activity from 53 to 59s] | | | | | | | | | | | | | | | | | | | | | | | | | | | | | |
| 15 | Tool Closes | | | | | | 59.0 | 3.0 | 62.0 | [Bar chart showing activity from 59 to 62s] | | | | | | | | | | | | | | | | | | | | | | | | | | | | | |
| 16 | Robot SA60R20 changes gripper to FSJ gun | | | | | | 59.0 | 15.0 | 74.0 | [Bar chart showing activity from 59 to 74s] | | | | | | | | | | | | | | | | | | | | | | | | | | | | | |
| 17 | Robot SA60R20 FSJ Rear Seat Asm in Stage2 | | | 27 | | | 74.0 | 81.0 | 155.0 | [Bar chart showing activity from 74 to 155s] | | | | | | | | | | | | | | | | | | | | | | | | | | | | | |
| 18 | Robot SA60R20 changes FSJ gun to Gripper | | | | | | 155.0 | 15.0 | 170.0 | [Bar chart showing activity from 155 to 170s] | | | | | | | | | | | | | | | | | | | | | | | | | | | | | |
| 19 | Robot SA60R20 loads Rear Seat Asm to UB150 conveyor | | | | | | 170.0 | 16.0 | 186.0 | [Bar chart showing activity from 170 to 186s] | | | | | | | | | | | | | | | | | | | | | | | | | | | | | |
| Station Cycle Time | | | | | | | | 191.0 | 191.0 | [Bar chart showing total cycle from 0 to 191s] | | | | | | | | | | | | | | | | | | | | | | | | | | | | | |
| Walk Summary (linear feet) | | 0 | | | | | | | | | | | | | | | | | | | | | | | | | | | | | | | | | | | | | |
| Glue Summary (linear mm) | | | 2715 | | | | | | | | | | | | | | | | | | | | | | | | | | | | | | | | | | | | |
| Friction Stir Summary | | | | 62 | | | | | | | | | | | | | | | | | | | | | | | | | | | | | | | | | | | |
| Hem Summary (linear mm) | | | | | 0 | | | | | | | | | | | | | | | | | | | | | | | | | | | | | | | | | | |
| MIG Summary (linear mm) | | | | | | 0 | | | | | | | | | | | | | | | | | | | | | | | | | | | | | | | | | |

Table 2.3.m: Station SA65 timing sheet

| | Description | Walk (feet) | Glue (mm) | FSJ | SPR | MIG (mm) | start | time (sec) | | seconds | | | | | | | | | | | | | | | | | | | | | | | | | | | | | |
|--|---|-------------|-----------|-----|-----|----------|-------|------------|-------|---|----|----|----|----|----|----|----|----|----|----|----|----|----|----|----|----|----|----|-----|-----|-----|-----|-----|-----|-----|-----|-----|-----|-----|
| | | | | | | | | Az. | sum | 5 | 10 | 15 | 20 | 25 | 30 | 35 | 40 | 45 | 50 | 55 | 60 | 65 | 70 | 75 | 80 | 85 | 90 | 95 | 100 | 105 | 110 | 115 | 120 | 125 | 130 | 135 | 140 | 145 | 150 |
| Front Wheelhouse Asm RL | | | | | | | | | | | | | | | | | | | | | | | | | | | | | | | | | | | | | | | |
| <i>CYCLE (BELOW) STARTS WITH A COMPLETED CYCLE</i> | | | | | | | | | | | | | | | | | | | | | | | | | | | | | | | | | | | | | | | |
| 1 | Operator loads (2) parts to presentation fixture | | | | | | 0.0 | 16.0 | 16.0 | [Bar chart showing activity from 0 to 16s] | | | | | | | | | | | | | | | | | | | | | | | | | | | | | |
| 2 | Operator load (1) part to SA65 | | | | | | 16.0 | 8.0 | 24.0 | [Bar chart showing activity from 16 to 24s] | | | | | | | | | | | | | | | | | | | | | | | | | | | | | |
| 3 | Operator depress palm button | | | | | | 24.0 | 1.5 | 25.5 | [Bar chart showing activity from 24 to 25.5s] | | | | | | | | | | | | | | | | | | | | | | | | | | | | | |
| 4 | Robot SA65R10 applies adhesive to Frt W/H and loads to SA65 | 720 | | | | | 25.5 | 15.6 | 41.1 | [Bar chart showing activity from 25.5 to 41.1s] | | | | | | | | | | | | | | | | | | | | | | | | | | | | | |
| 5 | Robot SA65R10 changes gripper to gripper | | | | | | 41.1 | 15.0 | 56.1 | [Bar chart showing activity from 41.1 to 56.1s] | | | | | | | | | | | | | | | | | | | | | | | | | | | | | |
| 6 | Robot SA65R10 applies adhesive to Shotgun and loads to SA65 | 380 | | | | | 56.1 | 13.9 | 70.0 | [Bar chart showing activity from 56.1 to 70s] | | | | | | | | | | | | | | | | | | | | | | | | | | | | | |
| 7 | Tool Closes | | | | | | 70.0 | 3.0 | 73.0 | [Bar chart showing activity from 70 to 73s] | | | | | | | | | | | | | | | | | | | | | | | | | | | | | |
| 8 | Robot SA65R10 changes gripper to Rivet gun | | | | | | 70.0 | 15.0 | 85.0 | [Bar chart showing activity from 70 to 85s] | | | | | | | | | | | | | | | | | | | | | | | | | | | | | |
| 9 | Robot SA65R10 Rivets (21 Spots) | | | | 21 | | 85.0 | 63.0 | 148.0 | [Bar chart showing activity from 85 to 148s] | | | | | | | | | | | | | | | | | | | | | | | | | | | | | |
| 10 | Tool Opens | | | | | | 148.0 | 3.0 | 151.0 | [Bar chart showing activity from 148 to 151s] | | | | | | | | | | | | | | | | | | | | | | | | | | | | | |
| 11 | Robot changes Rivet gun to gripper | | | | | | 148.0 | 15.0 | 163.0 | [Bar chart showing activity from 148 to 163s] | | | | | | | | | | | | | | | | | | | | | | | | | | | | | |
| 12 | Robot loads Frt W/H Asm to presentation fixture | | | | | | 163.0 | 12.0 | 175.0 | [Bar chart showing activity from 163 to 175s] | | | | | | | | | | | | | | | | | | | | | | | | | | | | | |
| 13 | Robot SA65R10 change gripper to gripper | | | | | | 175.0 | 15.0 | 190.0 | [Bar chart showing activity from 175 to 190s] | | | | | | | | | | | | | | | | | | | | | | | | | | | | | |
| Station Cycle Time | | | | | | | | 191.0 | 191.0 | [Bar chart showing total cycle from 0 to 191s] | | | | | | | | | | | | | | | | | | | | | | | | | | | | | |
| Walk Summary (linear feet) | | 0 | | | | | | | | | | | | | | | | | | | | | | | | | | | | | | | | | | | | | |
| Glue Summary (linear mm) | | | 1100 | | | | | | | | | | | | | | | | | | | | | | | | | | | | | | | | | | | | |
| Friction Stir Summary | | | | 0 | | | | | | | | | | | | | | | | | | | | | | | | | | | | | | | | | | | |
| Self Piercing Rivet Summary | | | | | 21 | | | | | | | | | | | | | | | | | | | | | | | | | | | | | | | | | | |
| MIG Summary (linear mm) | | | | | | 0 | | | | | | | | | | | | | | | | | | | | | | | | | | | | | | | | | |

Table 2.3.n: Station SA70 timing sheet

| | Description | Walk (feet) | Glue (mm) | FSJ | Spot Weld (mm) | MIG (mm) | Time (sec) | | seconds | | | | | | | | | | | | | | | | | | | | | | | | | | | | | | |
|--|---|-------------|-----------|-----|----------------|----------|------------|-------|---------|----|----|----|----|----|----|----|----|----|----|----|----|----|----|----|----|----|----|-----|-----|-----|-----|-----|-----|-----|-----|-----|-----|-----|-----|
| | | | | | | | start | sum | 5 | 10 | 15 | 20 | 25 | 30 | 35 | 40 | 45 | 50 | 55 | 60 | 65 | 70 | 75 | 80 | 85 | 90 | 95 | 100 | 105 | 110 | 115 | 120 | 125 | 130 | 135 | 140 | 145 | 150 | 155 |
| Body Side Inner | | | | | | | | | | | | | | | | | | | | | | | | | | | | | | | | | | | | | | | |
| <i>CYCLE (BELOW) STARTS WITH A COMPLETED CYCLE</i> | | | | | | | | | | | | | | | | | | | | | | | | | | | | | | | | | | | | | | | |
| 1 | Operator Loads 4 parts to SA70-10 | | | | | | 0.0 | 18.0 | 18.0 | | | | | | | | | | | | | | | | | | | | | | | | | | | | | | |
| 2 | Operator walks to SA70-20 and loads 2 parts to SA70-20 | | | | | | 18.0 | 15.0 | 33.0 | | | | | | | | | | | | | | | | | | | | | | | | | | | | | | |
| 3 | Operator loads 3 parts to SA70-30 | | | | | | 33.0 | 13.5 | 46.5 | | | | | | | | | | | | | | | | | | | | | | | | | | | | | | |
| 4 | Operator gets load assist and obtains sub assembly from station SA70-10 | | | | | | 46.5 | 15.0 | 61.5 | | | | | | | | | | | | | | | | | | | | | | | | | | | | | | |
| 5 | Operator walks to SA70-50 and loads sub assembly | | | | | | 61.5 | 18.0 | 79.5 | | | | | | | | | | | | | | | | | | | | | | | | | | | | | | |
| 6 | Robot SA70-10 picks 2 parts from SA70-10 and applies ped adhesive (A-Pir Otr Lwr & B-Pir Inr Asm) | | | | | | 18.0 | 17.0 | 35.0 | | | | | | | | | | | | | | | | | | | | | | | | | | | | | | |
| 7 | Robot SA70R10 loads 1 part to SA70-10 and 1 part to SA70-20 | | | | | | 35.0 | 15.0 | 50.0 | | | | | | | | | | | | | | | | | | | | | | | | | | | | | | |
| 8 | Robot SA70R10 picks 1 part from station (A-Pir Otr Upr) | | | | | | 50.0 | 6.0 | 56.0 | | | | | | | | | | | | | | | | | | | | | | | | | | | | | | |
| 9 | Robot SA70R10 applies ped adhesive then loads part back into station SA70-30 | | | | | | 56.0 | 11.0 | 67.0 | | | | | | | | | | | | | | | | | | | | | | | | | | | | | | |
| 10 | Robot SA70R10 drop end effector to storage and pick Friction Stir Unit | | | | | | 67.0 | 16.0 | 83.0 | | | | | | | | | | | | | | | | | | | | | | | | | | | | | | |
| 11 | Robot SA70R10 Friction Stir join 10 locations SA70-10 | | | | | | 83.0 | 30.0 | 113.0 | | | | | | | | | | | | | | | | | | | | | | | | | | | | | | |
| 12 | Robot SA70R10 Friction Stir join 12 locations SA70-20 | | | 10 | | | 113.0 | 36.0 | 149.0 | | | | | | | | | | | | | | | | | | | | | | | | | | | | | | |
| 13 | Robot SA70R10 Friction Stir join 6 locations SA70-30 | | | 6 | | | 149.0 | 18.0 | 167.0 | | | | | | | | | | | | | | | | | | | | | | | | | | | | | | |
| 14 | Robot SA70R10 drop Friction Stir unit and pick up end effector | | | | | | 167.0 | 16.0 | 183.0 | | | | | | | | | | | | | | | | | | | | | | | | | | | | | | |
| 15 | Robot SA70R10 picks sub assembly out of station SA70-20 | | | | | | 183.0 | 7.0 | 190.0 | | | | | | | | | | | | | | | | | | | | | | | | | | | | | | |
| 16 | Robot SA70R10 drops sub assembly in station SA70-30 | | | | | | 190.0 | 7.0 | 197.0 | | | | | | | | | | | | | | | | | | | | | | | | | | | | | | |
| 1 | Robot SA70R20 drops sub assembly in station SA70-30 (NOTE: Robot returns from above) | | | | | | 0.0 | 7.0 | 7.0 | | | | | | | | | | | | | | | | | | | | | | | | | | | | | | |
| 2 | Robot SA70R20 picks sub assembly from station SA70-30 | | | | | | 7.0 | 6.0 | 13.0 | | | | | | | | | | | | | | | | | | | | | | | | | | | | | | |
| 3 | Robot SA70R20 drop sub assembly in station SA70-40 | | | | | | 13.0 | 6.0 | 19.0 | | | | | | | | | | | | | | | | | | | | | | | | | | | | | | |
| 4 | Robot SA70R30 pick B-Pillar Outer Asm from SA70-40 | | | | | | 19.0 | 6.0 | 25.0 | | | | | | | | | | | | | | | | | | | | | | | | | | | | | | |
| 5 | Robot SA70R30 apply ped adhesive and load back into SA70-40 | | 200 | | | | 25.0 | 8.0 | 33.0 | | | | | | | | | | | | | | | | | | | | | | | | | | | | | | |
| 6 | Robot SA70R20 drop end effector to storage and pick Friction Stir Unit | | | | | | 19.0 | 15.0 | 34.0 | | | | | | | | | | | | | | | | | | | | | | | | | | | | | | |
| 7 | Robot SA70R20 Friction Stir 10 locations in station SA70-40 | | | | 8 | | 34.0 | 24.0 | 58.0 | | | | | | | | | | | | | | | | | | | | | | | | | | | | | | |
| 8 | Robot SA70R30 picks sub assembly from station SA70-50 | | | | | | 33.0 | 7.0 | 40.0 | | | | | | | | | | | | | | | | | | | | | | | | | | | | | | |
| 9 | Robot SA70R30 apply ped adhesive and wait for robot SA70R20 to complete friction stir joining | | 3200 | | | | 40.0 | 23.0 | 63.0 | | | | | | | | | | | | | | | | | | | | | | | | | | | | | | |
| 10 | Robot SA70R30 load sub assembly into SA70-40 | | | | | | 63.0 | 6.0 | 69.0 | | | | | | | | | | | | | | | | | | | | | | | | | | | | | | |
| 11 | Robot SA70R30 drop end effector to storage and pick Weld Gun | | | | | | 69.0 | 16.0 | 85.0 | | | | | | | | | | | | | | | | | | | | | | | | | | | | | | |
| 12 | Robot SA70R20 Friction Stir 25 locations in station SA70-40 | | | 30 | | | 69.0 | 90.0 | 159.0 | | | | | | | | | | | | | | | | | | | | | | | | | | | | | | |
| 13 | Robot SA70R30 resistance weld 30 locations in SA70-40 | | | | 32 | | 85.0 | 80.0 | 165.0 | | | | | | | | | | | | | | | | | | | | | | | | | | | | | | |
| 14 | Robot SA70R30 drop Weld Gun and pick up end effector | | | | | | 165.0 | 16.0 | 181.0 | | | | | | | | | | | | | | | | | | | | | | | | | | | | | | |
| 15 | Robot SA70R30 pick assembly from SA70-40 | | | | | | 181.0 | 6.0 | 187.0 | | | | | | | | | | | | | | | | | | | | | | | | | | | | | | |
| 16 | Robot SA70R30 ped weld 6 resistance spots | | | | 6 | | 0.0 | 15.0 | 15.0 | | | | | | | | | | | | | | | | | | | | | | | | | | | | | | |
| 17 | Robot SA70R30 unload to vision stand | | | | | | 15.0 | 7.0 | 22.0 | | | | | | | | | | | | | | | | | | | | | | | | | | | | | | |
| 18 | Robot SA70R40 inspects 50 points with camera | | | | | | 22.0 | 150.0 | 172.0 | | | | | | | | | | | | | | | | | | | | | | | | | | | | | | |
| 19 | Robot SA70R50 inspects 50 points with camera | | | | | | 22.0 | 150.0 | 172.0 | | | | | | | | | | | | | | | | | | | | | | | | | | | | | | |
| 20 | Robot SA70R60 unloads panel and drops into container | | | | | | 172.0 | 14.0 | 186.0 | | | | | | | | | | | | | | | | | | | | | | | | | | | | | | |
| Station Cycle Time | | | | | | | 191.0 | 191.0 | | | | | | | | | | | | | | | | | | | | | | | | | | | | | | | |
| Walk Summary (linear feet) | | 0 | | | | | | | | | | | | | | | | | | | | | | | | | | | | | | | | | | | | | |
| Glue Summary (linear mm) | | 3400 | | | | | | | | | | | | | | | | | | | | | | | | | | | | | | | | | | | | | |
| Friction Stir Summary | | | 66 | | | | | | | | | | | | | | | | | | | | | | | | | | | | | | | | | | | | |
| Spot Weld Summary (linear mm) | | | | 38 | | | | | | | | | | | | | | | | | | | | | | | | | | | | | | | | | | | |
| MIG Summary (linear mm) | | | | | 0 | | | | | | | | | | | | | | | | | | | | | | | | | | | | | | | | | | |

Table 2.3.q: Station SA85 timing sheet

| Description | Walk (feet) | Glue (mm) | FSJ | Weld Spots | MIG (mm) | start | time [sec] | | seconds | | | | | | | | | | | | | | | | | | | | | | | | | | | | | | |
|--|-------------|-----------|-----|------------|----------|-------|------------|--------------------|--------------------|----|----|----|----|----|----|----|----|----|----|----|----|----|----|----|----|----|----|-----|-----|-----|-----|-----|-----|-----|-----|-----|-----|-----|-----|
| | | | | | | | Az | sum | 5 | 10 | 15 | 20 | 25 | 30 | 35 | 40 | 45 | 50 | 55 | 60 | 65 | 70 | 75 | 80 | 85 | 90 | 95 | 100 | 105 | 110 | 115 | 120 | 125 | 130 | 135 | 140 | 145 | 150 | 155 |
| <i>Front Wheelhouse Asm R/L</i> | | | | | | | | | | | | | | | | | | | | | | | | | | | | | | | | | | | | | | | |
| <i>CYCLE (BELOW) STARTS WITH A COMPLETED CYCLE</i> | | | | | | | | | | | | | | | | | | | | | | | | | | | | | | | | | | | | | | | |
| 1 Operator loads 4 RH parts | | | | | | 0.0 | 22.0 | 22.0 | [Gantt chart bars] | | | | | | | | | | | | | | | | | | | | | | | | | | | | | | |
| 2 Operator loads 4 LH parts | | | | | | 22.0 | 22.0 | 44.0 | [Gantt chart bars] | | | | | | | | | | | | | | | | | | | | | | | | | | | | | | |
| 3 Operator depress palm button | | | | | | 44.0 | 1.0 | 45.0 | [Gantt chart bars] | | | | | | | | | | | | | | | | | | | | | | | | | | | | | | |
| 4 Fixture clamps extend | | | | | | 45.0 | 2.0 | 47.0 | [Gantt chart bars] | | | | | | | | | | | | | | | | | | | | | | | | | | | | | | |
| 5 Robot SA85R10 welds 16 RH spots | | | | 16 | | 47.0 | 48.0 | 95.0 | [Gantt chart bars] | | | | | | | | | | | | | | | | | | | | | | | | | | | | | | |
| 6 Robot SA85R10 welds 16 LH spots | | | | 16 | | 47.0 | 48.0 | 95.0 | [Gantt chart bars] | | | | | | | | | | | | | | | | | | | | | | | | | | | | | | |
| 7 Fixture clamps retract | | | | | | 95.0 | 2.0 | 97.0 | [Gantt chart bars] | | | | | | | | | | | | | | | | | | | | | | | | | | | | | | |
| 8 Operator unloads RH Asm | | | | | | 95.0 | 10.0 | 105.0 | [Gantt chart bars] | | | | | | | | | | | | | | | | | | | | | | | | | | | | | | |
| 9 Operator unloads LH Asm | | | | | | 105.0 | 10.0 | 115.0 | [Gantt chart bars] | | | | | | | | | | | | | | | | | | | | | | | | | | | | | | |
| Station Cycle Time | | | | | | 191.0 | 191.0 | [Gantt chart bars] | | | | | | | | | | | | | | | | | | | | | | | | | | | | | | | |
| Walk Summary (linear feet) | 0 | | | | | | | | | | | | | | | | | | | | | | | | | | | | | | | | | | | | | | |
| Glue Summary (linear mm) | | 0 | | | | | | | | | | | | | | | | | | | | | | | | | | | | | | | | | | | | | |
| Friction Stir Summary | | | 0 | | | | | | | | | | | | | | | | | | | | | | | | | | | | | | | | | | | | |
| Weld Spot Summary | | | | 32 | | | | | | | | | | | | | | | | | | | | | | | | | | | | | | | | | | | |
| MIG Summary (linear mm) | | | | | 0 | | | | | | | | | | | | | | | | | | | | | | | | | | | | | | | | | | |

Table 2.3.r: Station UB100 timing sheet

| Description | Walk (feet) | Glue (mm) | FSJ | HEM (mm) | MIG (mm) | start | time [sec] | | seconds | | | | | | | | | | | | | | | | | | | | | | | | | | | | | | |
|---|-------------|-----------|-----|----------|----------|-------|------------|--------------------|--------------------|----|----|----|----|----|----|----|----|----|----|----|----|----|----|----|----|----|----|-----|-----|-----|-----|-----|-----|-----|-----|-----|-----|-----|-----|
| | | | | | | | Az | sum | 5 | 10 | 15 | 20 | 25 | 30 | 35 | 40 | 45 | 50 | 55 | 60 | 65 | 70 | 75 | 80 | 85 | 90 | 95 | 100 | 105 | 110 | 115 | 120 | 125 | 130 | 135 | 140 | 145 | 150 | 155 |
| <i>Underbody (Loose Load Station)</i> | | | | | | | | | | | | | | | | | | | | | | | | | | | | | | | | | | | | | | | |
| <i>CYCLE (BELOW) STARTS WITH A COMPLETED CYCLE</i> | | | | | | | | | | | | | | | | | | | | | | | | | | | | | | | | | | | | | | | |
| 1 Transfer advances asm into Station | | | | | | 0.0 | 13.0 | 13.0 | [Gantt chart bars] | | | | | | | | | | | | | | | | | | | | | | | | | | | | | | |
| 2 Robot UB100R10 unloads C/M Sub Asm from Sta 30 | | | | | | 0.0 | 8.0 | 8.0 | [Gantt chart bars] | | | | | | | | | | | | | | | | | | | | | | | | | | | | | | |
| 3 Robot UB100R10 loads C/M Sub Asm to UB100 | | | | | | 8.0 | 9.0 | 17.0 | [Gantt chart bars] | | | | | | | | | | | | | | | | | | | | | | | | | | | | | | |
| 4 Robot UB100R10 unloads C/M Sub Asm from Sta 25.2 | | | | | | 17.0 | 9.0 | 26.0 | [Gantt chart bars] | | | | | | | | | | | | | | | | | | | | | | | | | | | | | | |
| 5 Robot UB100R10 loads C/m Sub Asm to Sta 30 | | | | | | 26.0 | 9.0 | 35.0 | [Gantt chart bars] | | | | | | | | | | | | | | | | | | | | | | | | | | | | | | |
| 6 Robot UB100R10 changes Gripper to Gripper | | | | | | 35.0 | 15.0 | 50.0 | [Gantt chart bars] | | | | | | | | | | | | | | | | | | | | | | | | | | | | | | |
| 7 Robot UB100R10 obtains and loads Side Rail Asm RH | | | | | | 50.0 | 20.0 | 70.0 | [Gantt chart bars] | | | | | | | | | | | | | | | | | | | | | | | | | | | | | | |
| 8 Robot UB100R10 obtains and loads Side rail Asm LH | | | | | | 70.0 | 20.0 | 90.0 | [Gantt chart bars] | | | | | | | | | | | | | | | | | | | | | | | | | | | | | | |
| 9 Robot UB100R10 changes Gripper to Gripper | | | | | | 90.0 | 15.0 | 105.0 | [Gantt chart bars] | | | | | | | | | | | | | | | | | | | | | | | | | | | | | | |
| 10 Operator loads (2) parts | | | | | | 17.0 | 8.0 | 25.0 | [Gantt chart bars] | | | | | | | | | | | | | | | | | | | | | | | | | | | | | | |
| 11 Operator depress palm button | | | | | | 25.0 | 1.5 | 26.5 | [Gantt chart bars] | | | | | | | | | | | | | | | | | | | | | | | | | | | | | | |
| Station Cycle Time | | | | | | 191.0 | 191.0 | [Gantt chart bars] | | | | | | | | | | | | | | | | | | | | | | | | | | | | | | | |
| Walk Summary (linear feet) | 0 | | | | | | | | | | | | | | | | | | | | | | | | | | | | | | | | | | | | | | |
| Glue Summary (linear mm) | | 0 | | | | | | | | | | | | | | | | | | | | | | | | | | | | | | | | | | | | | |
| Friction Stir Summary | | | 0 | | | | | | | | | | | | | | | | | | | | | | | | | | | | | | | | | | | | |
| Hem Summary (linear mm) | | | | 0 | | | | | | | | | | | | | | | | | | | | | | | | | | | | | | | | | | | |
| MIG Summary (linear mm) | | | | | 0 | | | | | | | | | | | | | | | | | | | | | | | | | | | | | | | | | | |

Table 2.3.s: Station UB110 timing sheet

| Description | Walk (feet) | Glue (mm) | FSJ | HEM (mm) | MIG (mm) | start | time [sec] | | seconds | | | | | | | | | | | | | | | | | | | | | | | | | | | | | | |
|---|-------------|-----------|-----|----------|----------|-------|------------|--------------------|--------------------|----|----|----|----|----|----|----|----|----|----|----|----|----|----|----|----|----|----|-----|-----|-----|-----|-----|-----|-----|-----|-----|-----|-----|-----|
| | | | | | | | Az | sum | 5 | 10 | 15 | 20 | 25 | 30 | 35 | 40 | 45 | 50 | 55 | 60 | 65 | 70 | 75 | 80 | 85 | 90 | 95 | 100 | 105 | 110 | 115 | 120 | 125 | 130 | 135 | 140 | 145 | 150 | 155 |
| <i>Underbody Geo Station (Rails and Crossmembers)</i> | | | | | | | | | | | | | | | | | | | | | | | | | | | | | | | | | | | | | | | |
| <i>CYCLE (BELOW) STARTS WITH A COMPLETED CYCLE</i> | | | | | | | | | | | | | | | | | | | | | | | | | | | | | | | | | | | | | | | |
| 1 Transfer advances asm into Station | | | | | | 0.0 | 13.0 | 13.0 | [Gantt chart bars] | | | | | | | | | | | | | | | | | | | | | | | | | | | | | | |
| 2 Robots UB110R10 and UB110R20 apply adhesive | | 1325 | | | | 13.0 | 20.0 | 33.0 | [Gantt chart bars] | | | | | | | | | | | | | | | | | | | | | | | | | | | | | | |
| 3 Tool Closes | | | | | | 33.0 | 10.0 | 43.0 | [Gantt chart bars] | | | | | | | | | | | | | | | | | | | | | | | | | | | | | | |
| 4 Robots UB110R30 thru UB110R40 FSJ (18 spots R/L) | | | | | | 43.0 | 54.0 | 97.0 | [Gantt chart bars] | | | | | | | | | | | | | | | | | | | | | | | | | | | | | | |
| 5 Tool Opens | | | | | | 97.0 | 5.0 | 102.0 | [Gantt chart bars] | | | | | | | | | | | | | | | | | | | | | | | | | | | | | | |
| Station Cycle Time | | | | | | 191.0 | 191.0 | [Gantt chart bars] | | | | | | | | | | | | | | | | | | | | | | | | | | | | | | | |
| Walk Summary (linear feet) | 0 | | | | | | | | | | | | | | | | | | | | | | | | | | | | | | | | | | | | | | |
| Glue Summary (linear mm) | | 2650 | | | | | | | | | | | | | | | | | | | | | | | | | | | | | | | | | | | | | |
| Friction Stir Summary | | | 0 | | | | | | | | | | | | | | | | | | | | | | | | | | | | | | | | | | | | |
| Hem Summary (linear mm) | | | | 0 | | | | | | | | | | | | | | | | | | | | | | | | | | | | | | | | | | | |
| MIG Summary (linear mm) | | | | | 0 | | | | | | | | | | | | | | | | | | | | | | | | | | | | | | | | | | |

Table 2.3.w: Station UB150 timing sheet

| Description | Walk (feet) | Glue (mm) | FSJ | HEM (mm) | MIG (mm) | start | time (sec) | | seconds | | | | | | | | | | | | | | | | | | | | | | | | | | | | | | | | | | | | | |
|--|--|-----------|------|----------|----------|-------|--------------|--------------|---------|----|----|----|----|----|----|----|----|----|----|----|----|----|----|----|----|----|----|-----|-----|-----|-----|-----|-----|-----|-----|-----|-----|-----|-----|-----|-----|-----|-----|-----|-----|-----|
| | | | | | | | Az. | sum | 5 | 10 | 15 | 20 | 25 | 30 | 35 | 40 | 45 | 50 | 55 | 60 | 65 | 70 | 75 | 80 | 85 | 90 | 95 | 100 | 105 | 110 | 115 | 120 | 125 | 130 | 135 | 140 | 145 | 150 | 155 | 160 | 165 | 170 | 175 | 180 | 185 | 190 |
| | | | | | | | | | | | | | | | | | | | | | | | | | | | | | | | | | | | | | | | | | | | | | | |
| <i>Underbody Geo Station (RR Seat and UBA-Pir Asm)</i> | | | | | | | | | | | | | | | | | | | | | | | | | | | | | | | | | | | | | | | | | | | | | | |
| <i>CYCLE (BELOW) STARTS WITH A COMPLETED CYCLE</i> | | | | | | | | | | | | | | | | | | | | | | | | | | | | | | | | | | | | | | | | | | | | | | |
| 1 | Transfer advances asm into Station | | | | | 0.0 | 13.0 | 13.0 | | | | | | | | | | | | | | | | | | | | | | | | | | | | | | | | | | | | | | |
| 2 | Tool Closes | | | | | 13.0 | 3.0 | 16.0 | | | | | | | | | | | | | | | | | | | | | | | | | | | | | | | | | | | | | | |
| 3 | Robot UB150R10 obtains and applies Ped adhesive to RR Seat Asm | | 4330 | | | 0.0 | 30.7 | 30.7 | | | | | | | | | | | | | | | | | | | | | | | | | | | | | | | | | | | | | | |
| 4 | Robot UB150R10 loads RR Seat Asm to Body | | | | | 30.7 | 10.0 | 40.7 | | | | | | | | | | | | | | | | | | | | | | | | | | | | | | | | | | | | | | |
| 5 | Robot UB150R10 changes Gripper to FSJ Gun | | | | | 40.7 | 15.0 | 55.7 | | | | | | | | | | | | | | | | | | | | | | | | | | | | | | | | | | | | | | |
| 6 | Robot UB150R10 and UB150R10 FSJ (13 spots R/L) | | | | | 55.7 | 39.0 | 94.7 | | | | | | | | | | | | | | | | | | | | | | | | | | | | | | | | | | | | | | |
| 7 | Robot UB150R10 changes FSJ Gun to Gripper | | | | | 94.7 | 15.0 | 109.7 | | | | | | | | | | | | | | | | | | | | | | | | | | | | | | | | | | | | | | |
| 8 | Robot UB150R30 and UB150R40 obtain and apply ped adhesive to A-pir Asm | | 280 | | | 30.7 | 4.9 | 35.6 | | | | | | | | | | | | | | | | | | | | | | | | | | | | | | | | | | | | | | |
| 9 | Robot UB150R30 and UB150R40 load A-Pir asms to Body | | | | | 35.6 | 8.0 | 43.6 | | | | | | | | | | | | | | | | | | | | | | | | | | | | | | | | | | | | | | |
| 10 | Tool Closes | | | | | 43.6 | 3.0 | 46.6 | | | | | | | | | | | | | | | | | | | | | | | | | | | | | | | | | | | | | | |
| 11 | Robot UB150R30 and UB150R40 change Gripper to Rivtac Gun | | | | | 43.6 | 15.0 | 58.6 | | | | | | | | | | | | | | | | | | | | | | | | | | | | | | | | | | | | | | |
| 12 | Robot UB150R30 and UB150R40 RivTac (10 spots R/L) | | | | | 58.6 | 20.0 | 78.6 | | | | | | | | | | | | | | | | | | | | | | | | | | | | | | | | | | | | | | |
| 13 | Robot UB150R30 and UB150R40 change Rivtac Gun to Gripper | | | | | 78.6 | 15.0 | 93.6 | | | | | | | | | | | | | | | | | | | | | | | | | | | | | | | | | | | | | | |
| 14 | Tool Opens | | | | | 109.7 | 3.0 | 112.7 | | | | | | | | | | | | | | | | | | | | | | | | | | | | | | | | | | | | | | |
| Station Cycle Time | | | | | | | 191.0 | 191.0 | | | | | | | | | | | | | | | | | | | | | | | | | | | | | | | | | | | | | | |
| Walk Summary (linear feet) | | 0 | | | | | | | | | | | | | | | | | | | | | | | | | | | | | | | | | | | | | | | | | | | | |
| Glue Summary (linear mm) | | 5690 | | | | | | | | | | | | | | | | | | | | | | | | | | | | | | | | | | | | | | | | | | | | |
| Friction Stir Summary | | 0 | | | | | | | | | | | | | | | | | | | | | | | | | | | | | | | | | | | | | | | | | | | | |
| Hem Summary (linear mm) | | 0 | | | | | | | | | | | | | | | | | | | | | | | | | | | | | | | | | | | | | | | | | | | | |
| MIG Summary (linear mm) | | 0 | | | | | | | | | | | | | | | | | | | | | | | | | | | | | | | | | | | | | | | | | | | | |

Table 2.3.x: Station UB160 timing sheet

| Description | Walk (feet) | Glue (mm) | FSJ | HEM (mm) | MIG (mm) | start | time (sec) | | seconds | | | | | | | | | | | | | | | | | | | | | | | | | | | | | | | | | | | | | |
|--|------------------------------------|-----------|-----|----------|----------|-------|--------------|--------------|---------|----|----|----|----|----|----|----|----|----|----|----|----|----|----|----|----|----|----|-----|-----|-----|-----|-----|-----|-----|-----|-----|-----|-----|-----|-----|-----|-----|-----|-----|-----|-----|
| | | | | | | | Az. | sum | 5 | 10 | 15 | 20 | 25 | 30 | 35 | 40 | 45 | 50 | 55 | 60 | 65 | 70 | 75 | 80 | 85 | 90 | 95 | 100 | 105 | 110 | 115 | 120 | 125 | 130 | 135 | 140 | 145 | 150 | 155 | 160 | 165 | 170 | 175 | 180 | 185 | 190 |
| | | | | | | | | | | | | | | | | | | | | | | | | | | | | | | | | | | | | | | | | | | | | | | |
| <i>Underbody Sub Asm (Idle Station)</i> | | | | | | | | | | | | | | | | | | | | | | | | | | | | | | | | | | | | | | | | | | | | | | |
| <i>CYCLE (BELOW) STARTS WITH A COMPLETED CYCLE</i> | | | | | | | | | | | | | | | | | | | | | | | | | | | | | | | | | | | | | | | | | | | | | | |
| 1 | Transfer advances asm into Station | | | | | 0.0 | 13.0 | 13.0 | | | | | | | | | | | | | | | | | | | | | | | | | | | | | | | | | | | | | | |
| Station Cycle Time | | | | | | | 191.0 | 191.0 | | | | | | | | | | | | | | | | | | | | | | | | | | | | | | | | | | | | | | |
| Walk Summary (linear feet) | | 0 | | | | | | | | | | | | | | | | | | | | | | | | | | | | | | | | | | | | | | | | | | | | |
| Glue Summary (linear mm) | | 0 | | | | | | | | | | | | | | | | | | | | | | | | | | | | | | | | | | | | | | | | | | | | |
| Friction Stir Summary | | 0 | | | | | | | | | | | | | | | | | | | | | | | | | | | | | | | | | | | | | | | | | | | | |
| Hem Summary (linear mm) | | 0 | | | | | | | | | | | | | | | | | | | | | | | | | | | | | | | | | | | | | | | | | | | | |
| MIG Summary (linear mm) | | 0 | | | | | | | | | | | | | | | | | | | | | | | | | | | | | | | | | | | | | | | | | | | | |

Table 2.3.y: Station UB170 timing sheet

| Description | Walk (feet) | Glue (mm) | FSJ | HEM (mm) | MIG (mm) | start | time (sec) | | seconds | | | | | | | | | | | | | | | | | | | | | | | | | | | | | | | | | | | | | |
|---|---|-----------|------|----------|----------|-------|--------------|--------------|---------|----|----|----|----|----|----|----|----|----|----|----|----|----|----|----|----|----|----|-----|-----|-----|-----|-----|-----|-----|-----|-----|-----|-----|-----|-----|-----|-----|-----|-----|-----|-----|
| | | | | | | | Az. | sum | 5 | 10 | 15 | 20 | 25 | 30 | 35 | 40 | 45 | 50 | 55 | 60 | 65 | 70 | 75 | 80 | 85 | 90 | 95 | 100 | 105 | 110 | 115 | 120 | 125 | 130 | 135 | 140 | 145 | 150 | 155 | 160 | 165 | 170 | 175 | 180 | 185 | 190 |
| | | | | | | | | | | | | | | | | | | | | | | | | | | | | | | | | | | | | | | | | | | | | | | |
| <i>Underbody Sub Asm (Frt WH, Pnl Fir Ctr R/L and Pnl RR Closeout R/L Load)</i> | | | | | | | | | | | | | | | | | | | | | | | | | | | | | | | | | | | | | | | | | | | | | | |
| <i>CYCLE (BELOW) STARTS WITH A COMPLETED CYCLE</i> | | | | | | | | | | | | | | | | | | | | | | | | | | | | | | | | | | | | | | | | | | | | | | |
| 1 | Transfer advances asm into Station | | | | | 0.0 | 13.0 | 13.0 | | | | | | | | | | | | | | | | | | | | | | | | | | | | | | | | | | | | | | |
| 2 | Tool Closes | | | | | 13.0 | 3.0 | 16.0 | | | | | | | | | | | | | | | | | | | | | | | | | | | | | | | | | | | | | | |
| 3 | Robot UB170R30 and UB170R40 obtain and apply PED adhesive to Frt WH Asm | | 600 | | | 0.0 | 11.0 | 11.0 | | | | | | | | | | | | | | | | | | | | | | | | | | | | | | | | | | | | | | |
| 4 | Robot UB170R30 and UB170R40 load Frt WH to Body | | | | | 16.0 | 10.0 | 26.0 | | | | | | | | | | | | | | | | | | | | | | | | | | | | | | | | | | | | | | |
| 5 | Robot UB170R30 and UB170R40 change Gripper to Rivtac Gun | | | | | 26.0 | 15.0 | 41.0 | | | | | | | | | | | | | | | | | | | | | | | | | | | | | | | | | | | | | | |
| 6 | Robot UB170R30 and UB170R40 RivTac (37 spots R/L) | | | | | 41.0 | 74.0 | 115.0 | | | | | | | | | | | | | | | | | | | | | | | | | | | | | | | | | | | | | | |
| 7 | Robot UB170R30 and UB170R40 change Rivtac Gun to Gripper | | | | | 115.0 | 15.0 | 130.0 | | | | | | | | | | | | | | | | | | | | | | | | | | | | | | | | | | | | | | |
| 8 | Robot UB170R10 and UB170R20 obtain Pnl RR Closeout | | | | | 0.0 | 8.0 | 8.0 | | | | | | | | | | | | | | | | | | | | | | | | | | | | | | | | | | | | | | |
| 9 | Robot UB170R10 and UB170R20 apply Ped Adhesive to Pnl RR Closeout | | 1100 | | | 8.0 | 8.5 | 16.5 | | | | | | | | | | | | | | | | | | | | | | | | | | | | | | | | | | | | | | |
| 10 | Robot UB170R10 and UB170R20 load Pnl RR Closeout | | | | | 16.5 | 8.0 | 24.5 | | | | | | | | | | | | | | | | | | | | | | | | | | | | | | | | | | | | | | |
| 11 | Tool Closes | | | | | 24.5 | 3.0 | 27.5 | | | | | | | | | | | | | | | | | | | | | | | | | | | | | | | | | | | | | | |
| 12 | Robot UB170R10 and UB170R20 change Gripper to FSJ Gun | | | | | 24.5 | 20.0 | 44.5 | | | | | | | | | | | | | | | | | | | | | | | | | | | | | | | | | | | | | | |
| 13 | Robot UB170R10 and UB170R20 FSJ (12 spots R/L) | | | | | 44.5 | 36.0 | 80.5 | | | | | | | | | | | | | | | | | | | | | | | | | | | | | | | | | | | | | | |
| 14 | Tool Opens | | | | | 80.5 | 3.0 | 83.5 | | | | | | | | | | | | | | | | | | | | | | | | | | | | | | | | | | | | | | |
| 15 | Robot UB170R10 and UB170R20 change FSJ Gun to Gripper | | | | | 80.5 | 15.0 | 95.5 | | | | | | | | | | | | | | | | | | | | | | | | | | | | | | | | | | | | | | |
| 1 | Operators load (2) parts to Presentation fixtures | | | | | 8.0 | 16.0 | 24.0 | | | | | | | | | | | | | | | | | | | | | | | | | | | | | | | | | | | | | | |
| 2 | Operators depress palm button | | | | | 24.0 | 1.5 | 25.5 | | | | | | | | | | | | | | | | | | | | | | | | | | | | | | | | | | | | | | |
| Station Cycle Time | | | | | | | 191.0 | 191.0 | | | | | | | | | | | | | | | | | | | | | | | | | | | | | | | | | | | | | | |
| Walk Summary (linear feet) | | 0 | | | | | | | | | | | | | | | | | | | | | | | | | | | | | | | | | | | | | | | | | | | | |
| Glue Summary (linear mm) | | 3400 | | | | | | | | | | | | | | | | | | | | | | | | | | | | | | | | | | | | | | | | | | | | |
| Friction Stir Summary | | 0 | | | | | | | | | | | | | | | | | | | | | | | | | | | | | | | | | | | | | | | | | | | | |
| Hem Summary (linear mm) | | 0 | | | | | | | | | | | | | | | | | | | | | | | | | | | | | | | | | | | | | | | | | | | | |
| MIG Summary (linear mm) | | 0 | | | | | | | | | | | | | | | | | | | | | | | | | | | | | | | | | | | | | | | | | | | | |

Table 2.3.ab: Station UB200 timing sheet

| Description | Walk (feet) | Glue (mm) | FSJ | HEM (mm) | MIG (mm) | start | time [sec] | | seconds | | | | | | | | | | | | | | | | | | | | | | | | | | | | | | | | | | | |
|--|----------------|--------------|-----|-------------|-------------|-------|------------|-------|----------------------------|----|----|----|----|----|----|----|----|----|----|----|----|----|----|----|----|----|----|-----|-----|-----|-----|-----|-----|-----|-----|-----|-----|-----|-----|-----|-----|-----|-----|-----|
| | | | | | | | Az. | sum | 5 | 10 | 15 | 20 | 25 | 30 | 35 | 40 | 45 | 50 | 55 | 60 | 65 | 70 | 75 | 80 | 85 | 90 | 95 | 100 | 105 | 110 | 115 | 120 | 125 | 130 | 135 | 140 | 145 | 150 | 155 | 160 | 165 | 170 | 175 | 180 |
| Underbody Respot Station | | | | | | | | | | | | | | | | | | | | | | | | | | | | | | | | | | | | | | | | | | | | |
| <i>CYCLE (BELOW) STARTS WITH A COMPLETED CYCLE</i> | | | | | | | | | | | | | | | | | | | | | | | | | | | | | | | | | | | | | | | | | | | | |
| 1 Transfer advances asm into Station | | | | | | 0.0 | 13.0 | 13.0 | | | | | | | | | | | | | | | | | | | | | | | | | | | | | | | | | | | | |
| 2 Tool Closes | | | | | | 13.0 | 3.0 | 16.0 | | | | | | | | | | | | | | | | | | | | | | | | | | | | | | | | | | | | |
| 3 Robot UB200R10 Respot (35 Spots) | | | | | | 16.0 | 105.0 | 121.0 | | | | | | | | | | | | | | | | | | | | | | | | | | | | | | | | | | | | |
| 4 Robot UB200R20 Respot (35 Spots) | | | | | | 16.0 | 105.0 | 121.0 | | | | | | | | | | | | | | | | | | | | | | | | | | | | | | | | | | | | |
| 5 Robot UB200R30 Respot (35 Spots) | | | | | | 16.0 | 105.0 | 121.0 | | | | | | | | | | | | | | | | | | | | | | | | | | | | | | | | | | | | |
| 6 Robot UB200R40 Respot (35 Spots) | | | | | | 16.0 | 105.0 | 121.0 | | | | | | | | | | | | | | | | | | | | | | | | | | | | | | | | | | | | |
| 7 Tool Opens | | | | | | 121.0 | 3.0 | 124.0 | | | | | | | | | | | | | | | | | | | | | | | | | | | | | | | | | | | | |
| Station Cycle Time | | | | | | 191.0 | 191.0 | | [Gantt bar from 0 to 191s] | | | | | | | | | | | | | | | | | | | | | | | | | | | | | | | | | | | |
| Walk Summary (linear feet) | 0 | | | | | | | | | | | | | | | | | | | | | | | | | | | | | | | | | | | | | | | | | | | |
| Glue Summary (linear mm) | | 0 | | | | | | | | | | | | | | | | | | | | | | | | | | | | | | | | | | | | | | | | | | |
| Friction Stir Summary | | | 0 | | | | | | | | | | | | | | | | | | | | | | | | | | | | | | | | | | | | | | | | | |
| Hem Summary (linear mm) | | | | 0 | | | | | | | | | | | | | | | | | | | | | | | | | | | | | | | | | | | | | | | | |
| MIG Summary (linear mm) | | | | | 0 | | | | | | | | | | | | | | | | | | | | | | | | | | | | | | | | | | | | | | | |

Table 2.3.ac: Station UB210 timing sheet

| Description | Walk (feet) | Glue (mm) | FSJ | HEM (mm) | MIG (mm) | start | time [sec] | | seconds | | | | | | | | | | | | | | | | | | | | | | | | | | | | | | | | | | | | |
|--|----------------|--------------|-----|-------------|-------------|-------|------------|-------|----------------------------|----|----|----|----|----|----|----|----|----|----|----|----|----|----|----|----|----|----|-----|-----|-----|-----|-----|-----|-----|-----|-----|-----|-----|-----|-----|-----|-----|-----|-----|-----|
| | | | | | | | Az. | sum | 5 | 10 | 15 | 20 | 25 | 30 | 35 | 40 | 45 | 50 | 55 | 60 | 65 | 70 | 75 | 80 | 85 | 90 | 95 | 100 | 105 | 110 | 115 | 120 | 125 | 130 | 135 | 140 | 145 | 150 | 155 | 160 | 165 | 170 | 175 | 180 | 185 |
| Underbody Stud Apply Station | | | | | | | | | | | | | | | | | | | | | | | | | | | | | | | | | | | | | | | | | | | | | |
| <i>CYCLE (BELOW) STARTS WITH A COMPLETED CYCLE</i> | | | | | | | | | | | | | | | | | | | | | | | | | | | | | | | | | | | | | | | | | | | | | |
| 1 Transfer advances asm into Station | | | | | | 0.0 | 13.0 | 13.0 | | | | | | | | | | | | | | | | | | | | | | | | | | | | | | | | | | | | | |
| 2 Tool Closes | | | | | | 13.0 | 3.0 | 16.0 | | | | | | | | | | | | | | | | | | | | | | | | | | | | | | | | | | | | | |
| 3 Robot UB210R10 Applies Studs (25 Spots) | | | | | | 16.0 | 125.0 | 141.0 | | | | | | | | | | | | | | | | | | | | | | | | | | | | | | | | | | | | | |
| 4 Robot UB210R20 Applies Studs (25 Spots) | | | | | | 16.0 | 125.0 | 141.0 | | | | | | | | | | | | | | | | | | | | | | | | | | | | | | | | | | | | | |
| 5 Robot UB210R30 Applies Studs (25 Spots) | | | | | | 16.0 | 125.0 | 141.0 | | | | | | | | | | | | | | | | | | | | | | | | | | | | | | | | | | | | | |
| 6 Robot UB210R40 Applies Studs (25 Spots) | | | | | | 16.0 | 125.0 | 141.0 | | | | | | | | | | | | | | | | | | | | | | | | | | | | | | | | | | | | | |
| 7 Tool Opens | | | | | | 141.0 | 3.0 | 144.0 | | | | | | | | | | | | | | | | | | | | | | | | | | | | | | | | | | | | | |
| Station Cycle Time | | | | | | 191.0 | 191.0 | | [Gantt bar from 0 to 191s] | | | | | | | | | | | | | | | | | | | | | | | | | | | | | | | | | | | | |
| Walk Summary (linear feet) | 0 | | | | | | | | | | | | | | | | | | | | | | | | | | | | | | | | | | | | | | | | | | | | |
| Glue Summary (linear mm) | | 0 | | | | | | | | | | | | | | | | | | | | | | | | | | | | | | | | | | | | | | | | | | | |
| Friction Stir Summary | | | 0 | | | | | | | | | | | | | | | | | | | | | | | | | | | | | | | | | | | | | | | | | | |
| Hem Summary (linear mm) | | | | 0 | | | | | | | | | | | | | | | | | | | | | | | | | | | | | | | | | | | | | | | | | |
| MIG Summary (linear mm) | | | | | 0 | | | | | | | | | | | | | | | | | | | | | | | | | | | | | | | | | | | | | | | | |

Table 2.3.ad: Station UB220 timing sheet

| Description | Walk (feet) | Glue (mm) | FSJ | HEM (mm) | MIG (mm) | start | time [sec] | | seconds | | | | | | | | | | | | | | | | | | | | | | | | | | | | | | | | | | | | |
|--|----------------|--------------|-----|-------------|-------------|-------|------------|-------|----------------------------|----|----|----|----|----|----|----|----|----|----|----|----|----|----|----|----|----|----|-----|-----|-----|-----|-----|-----|-----|-----|-----|-----|-----|-----|-----|-----|-----|-----|-----|-----|
| | | | | | | | Az. | sum | 5 | 10 | 15 | 20 | 25 | 30 | 35 | 40 | 45 | 50 | 55 | 60 | 65 | 70 | 75 | 80 | 85 | 90 | 95 | 100 | 105 | 110 | 115 | 120 | 125 | 130 | 135 | 140 | 145 | 150 | 155 | 160 | 165 | 170 | 175 | 180 | 185 |
| Underbody Vision Station | | | | | | | | | | | | | | | | | | | | | | | | | | | | | | | | | | | | | | | | | | | | | |
| <i>CYCLE (BELOW) STARTS WITH A COMPLETED CYCLE</i> | | | | | | | | | | | | | | | | | | | | | | | | | | | | | | | | | | | | | | | | | | | | | |
| 1 Transfer advances asm into Station | | | | | | 0.0 | 13.0 | 13.0 | | | | | | | | | | | | | | | | | | | | | | | | | | | | | | | | | | | | | |
| 2 Tool Closes | | | | | | 13.0 | 3.0 | 16.0 | | | | | | | | | | | | | | | | | | | | | | | | | | | | | | | | | | | | | |
| 3 Robot UB220R10 Vision Check (50 locations) | | | | | | 16.0 | 150.0 | 166.0 | | | | | | | | | | | | | | | | | | | | | | | | | | | | | | | | | | | | | |
| 4 Robot UB220R20 Vision Check (50 locations) | | | | | | 16.0 | 150.0 | 166.0 | | | | | | | | | | | | | | | | | | | | | | | | | | | | | | | | | | | | | |
| 5 Tool Opens | | | | | | 166.0 | 3.0 | 169.0 | | | | | | | | | | | | | | | | | | | | | | | | | | | | | | | | | | | | | |
| Station Cycle Time | | | | | | 191.0 | 191.0 | | [Gantt bar from 0 to 191s] | | | | | | | | | | | | | | | | | | | | | | | | | | | | | | | | | | | | |
| Walk Summary (linear feet) | 0 | | | | | | | | | | | | | | | | | | | | | | | | | | | | | | | | | | | | | | | | | | | | |
| Glue Summary (linear mm) | | 0 | | | | | | | | | | | | | | | | | | | | | | | | | | | | | | | | | | | | | | | | | | | |
| Friction Stir Summary | | | 0 | | | | | | | | | | | | | | | | | | | | | | | | | | | | | | | | | | | | | | | | | | |
| Hem Summary (linear mm) | | | | 0 | | | | | | | | | | | | | | | | | | | | | | | | | | | | | | | | | | | | | | | | | |
| MIG Summary (linear mm) | | | | | 0 | | | | | | | | | | | | | | | | | | | | | | | | | | | | | | | | | | | | | | | | |

Table 2.3.am: Station FR170 timing sheet

| Description | Walk (feet) | Glue (mm) | FSJ | HEM (mm) | MIG (mm) | start | time (sec) | | seconds | | | | | | | | | | | | | | | | | | | | | | | | | | | | | | | | | | | | | |
|--|-------------|-----------|-----|----------|----------|-------|------------|-------|--|----|----|----|----|----|----|----|----|----|----|----|----|----|----|----|----|----|----|-----|-----|-----|-----|-----|-----|-----|-----|-----|-----|-----|-----|-----|-----|-----|-----|-----|-----|-----|
| | | | | | | | Az. | sum | 5 | 10 | 15 | 20 | 25 | 30 | 35 | 40 | 45 | 50 | 55 | 60 | 65 | 70 | 75 | 80 | 85 | 90 | 95 | 100 | 105 | 110 | 115 | 120 | 125 | 130 | 135 | 140 | 145 | 150 | 155 | 160 | 165 | 170 | 175 | 180 | 185 | 190 |
| | | | | | | | | | | | | | | | | | | | | | | | | | | | | | | | | | | | | | | | | | | | | | | |
| Framing (Vision Station) | | | | | | | | | | | | | | | | | | | | | | | | | | | | | | | | | | | | | | | | | | | | | | |
| <i>CYCLE (BELOW) STARTS WITH A COMPLETED CYCLE</i> | | | | | | | | | | | | | | | | | | | | | | | | | | | | | | | | | | | | | | | | | | | | | | |
| 1 Transfer advances asm into Station | | | | | | 0.0 | 13.0 | 13.0 | [Bar chart showing activity from 0 to 13s] | | | | | | | | | | | | | | | | | | | | | | | | | | | | | | | | | | | | | |
| 2 Tool Closes | | | | | | 13.0 | 3.0 | 16.0 | [Bar chart showing activity from 13 to 16s] | | | | | | | | | | | | | | | | | | | | | | | | | | | | | | | | | | | | | |
| 3 Robot FR17010 Vision Check (50 locations) | | | | | | 16.0 | 150.0 | 166.0 | [Bar chart showing activity from 16 to 166s] | | | | | | | | | | | | | | | | | | | | | | | | | | | | | | | | | | | | | |
| 4 Robot FR17020 Vision Check (50 locations) | | | | | | 16.0 | 150.0 | 166.0 | [Bar chart showing activity from 16 to 166s] | | | | | | | | | | | | | | | | | | | | | | | | | | | | | | | | | | | | | |
| 5 Tool Opens | | | | | | 166.0 | 3.0 | 169.0 | [Bar chart showing activity from 166 to 169s] | | | | | | | | | | | | | | | | | | | | | | | | | | | | | | | | | | | | | |
| Station Cycle Time | | | | | | 191.0 | 191.0 | | [Bar chart showing total cycle from 0 to 191s] | | | | | | | | | | | | | | | | | | | | | | | | | | | | | | | | | | | | | |
| Walk Summary (linear feet) | 0 | | | | | | | | | | | | | | | | | | | | | | | | | | | | | | | | | | | | | | | | | | | | | |
| Glue Summary (linear mm) | | 0 | | | | | | | | | | | | | | | | | | | | | | | | | | | | | | | | | | | | | | | | | | | | |
| Friction Str Summary | | | 0 | | | | | | | | | | | | | | | | | | | | | | | | | | | | | | | | | | | | | | | | | | | |
| Hem Summary (linear mm) | | | | 0 | | | | | | | | | | | | | | | | | | | | | | | | | | | | | | | | | | | | | | | | | | |
| MIG Summary (linear mm) | | | | | 0 | | | | | | | | | | | | | | | | | | | | | | | | | | | | | | | | | | | | | | | | | |

Table 2.3.an: Station FR180 timing sheet

| Description | Walk (feet) | Glue (mm) | FSJ | HEM (mm) | MIG (mm) | start | time (sec) | | seconds | | | | | | | | | | | | | | | | | | | | | | | | | | | | | | | | | | | | | |
|--|-------------|-----------|-----|----------|----------|-------|------------|-------|---|----|----|----|----|----|----|----|----|----|----|----|----|----|----|----|----|----|----|-----|-----|-----|-----|-----|-----|-----|-----|-----|-----|-----|-----|-----|-----|-----|-----|-----|-----|-----|
| | | | | | | | Az. | sum | 5 | 10 | 15 | 20 | 25 | 30 | 35 | 40 | 45 | 50 | 55 | 60 | 65 | 70 | 75 | 80 | 85 | 90 | 95 | 100 | 105 | 110 | 115 | 120 | 125 | 130 | 135 | 140 | 145 | 150 | 155 | 160 | 165 | 170 | 175 | 180 | 185 | 190 |
| | | | | | | | | | | | | | | | | | | | | | | | | | | | | | | | | | | | | | | | | | | | | | | |
| Framing Bolt Up Station (FR/RR Bumper and Rad Supt) | | | | | | | | | | | | | | | | | | | | | | | | | | | | | | | | | | | | | | | | | | | | | | |
| <i>CYCLE (BELOW) STARTS WITH A COMPLETED CYCLE</i> | | | | | | | | | | | | | | | | | | | | | | | | | | | | | | | | | | | | | | | | | | | | | | |
| 1 Transfer advances assembly to next station | | | | | | 0.0 | 13.0 | 13.0 | [Bar chart showing activity from 0 to 13s] | | | | | | | | | | | | | | | | | | | | | | | | | | | | | | | | | | | | | |
| 2 Operators 1 & 2 load Front Bumper to Manipulator | | | | | | 0.0 | 6.0 | 6.0 | [Bar chart showing activity from 0 to 6s] | | | | | | | | | | | | | | | | | | | | | | | | | | | | | | | | | | | | | |
| 3 Operators 1 & 2 load Module Front to Manipulator | | | | | | 6.0 | 6.0 | 12.0 | [Bar chart showing activity from 6 to 12s] | | | | | | | | | | | | | | | | | | | | | | | | | | | | | | | | | | | | | |
| 4 Operators 1 & 2 position manipulator to Body | | | | | | 12.0 | 6.0 | 18.0 | [Bar chart showing activity from 12 to 18s] | | | | | | | | | | | | | | | | | | | | | | | | | | | | | | | | | | | | | |
| 5 Operators 1 & 2 run bolts to Module Front (4 R/L) | | | | | | 18.0 | 45.0 | 63.0 | [Bar chart showing activity from 18 to 63s] | | | | | | | | | | | | | | | | | | | | | | | | | | | | | | | | | | | | | |
| 6 Operators 1 & 2 run bolts to Front Bumper (4 R/L) | | | | | | 63.0 | 45.0 | 108.0 | [Bar chart showing activity from 63 to 108s] | | | | | | | | | | | | | | | | | | | | | | | | | | | | | | | | | | | | | |
| 7 Operators 1 & 2 remove manipulator | | | | | | 108.0 | 3.5 | 111.5 | [Bar chart showing activity from 108 to 111.5s] | | | | | | | | | | | | | | | | | | | | | | | | | | | | | | | | | | | | | |
| 8 Operators 1 & 2 walk to rear of body | | | | | | 111.5 | 6.0 | 117.5 | [Bar chart showing activity from 111.5 to 117.5s] | | | | | | | | | | | | | | | | | | | | | | | | | | | | | | | | | | | | | |
| 9 Operators 1 & 2 load Rear Bumper to manipulator | | | | | | 117.5 | 6.0 | 123.5 | [Bar chart showing activity from 117.5 to 123.5s] | | | | | | | | | | | | | | | | | | | | | | | | | | | | | | | | | | | | | |
| 10 Operators 1 & 2 position manipulator to Body | | | | | | 123.5 | 6.0 | 129.5 | [Bar chart showing activity from 123.5 to 129.5s] | | | | | | | | | | | | | | | | | | | | | | | | | | | | | | | | | | | | | |
| 11 Operators 1 & 2 run bolts to Rear Bumper (4 R/L) | | | | | | 129.5 | 45.0 | 174.5 | [Bar chart showing activity from 129.5 to 174.5s] | | | | | | | | | | | | | | | | | | | | | | | | | | | | | | | | | | | | | |
| 12 Operators 1 & 2 remove manipulator | | | | | | 174.5 | 3.5 | 178.0 | [Bar chart showing activity from 174.5 to 178s] | | | | | | | | | | | | | | | | | | | | | | | | | | | | | | | | | | | | | |
| 13 Operators 1 & 2 press button | | | | | | 178.0 | 1.5 | 179.5 | [Bar chart showing activity from 178 to 179.5s] | | | | | | | | | | | | | | | | | | | | | | | | | | | | | | | | | | | | | |
| Station Cycle Time | | | | | | 191.0 | 191.0 | | [Bar chart showing total cycle from 0 to 191s] | | | | | | | | | | | | | | | | | | | | | | | | | | | | | | | | | | | | | |
| Walk Summary (linear feet) | 0 | | | | | | | | | | | | | | | | | | | | | | | | | | | | | | | | | | | | | | | | | | | | | |
| Glue Summary (linear mm) | | 0 | | | | | | | | | | | | | | | | | | | | | | | | | | | | | | | | | | | | | | | | | | | | |
| Friction Str Summary | | | 0 | | | | | | | | | | | | | | | | | | | | | | | | | | | | | | | | | | | | | | | | | | | |
| Hem Summary (linear mm) | | | | 0 | | | | | | | | | | | | | | | | | | | | | | | | | | | | | | | | | | | | | | | | | | |
| MIG Summary (linear mm) | | | | | 0 | | | | | | | | | | | | | | | | | | | | | | | | | | | | | | | | | | | | | | | | | |

Table 2.3.ao: Station FR190 timing sheet

| Description | Walk (feet) | Glue (mm) | FSJ | HEM (mm) | MIG (mm) | start | time (sec) | | seconds | | | | | | | | | | | | | | | | | | | | | | | | | | | | | | | | | | | | | |
|--|-------------|-----------|-----|----------|----------|-------|------------|-------|--|----|----|----|----|----|----|----|----|----|----|----|----|----|----|----|----|----|----|-----|-----|-----|-----|-----|-----|-----|-----|-----|-----|-----|-----|-----|-----|-----|-----|-----|-----|-----|
| | | | | | | | Az. | sum | 5 | 10 | 15 | 20 | 25 | 30 | 35 | 40 | 45 | 50 | 55 | 60 | 65 | 70 | 75 | 80 | 85 | 90 | 95 | 100 | 105 | 110 | 115 | 120 | 125 | 130 | 135 | 140 | 145 | 150 | 155 | 160 | 165 | 170 | 175 | 180 | 185 | 190 |
| | | | | | | | | | | | | | | | | | | | | | | | | | | | | | | | | | | | | | | | | | | | | | | |
| Framing (Surface Finish Station) | | | | | | | | | | | | | | | | | | | | | | | | | | | | | | | | | | | | | | | | | | | | | | |
| <i>CYCLE (BELOW) STARTS WITH A COMPLETED CYCLE</i> | | | | | | | | | | | | | | | | | | | | | | | | | | | | | | | | | | | | | | | | | | | | | | |
| 1 Transfer advances asm into Station | | | | | | 0.0 | 13.0 | 13.0 | [Bar chart showing activity from 0 to 13s] | | | | | | | | | | | | | | | | | | | | | | | | | | | | | | | | | | | | | |
| 2 Operators inspect and repair | | | | | | 13.0 | 150.0 | 163.0 | [Bar chart showing activity from 13 to 163s] | | | | | | | | | | | | | | | | | | | | | | | | | | | | | | | | | | | | | |
| Station Cycle Time | | | | | | 191.0 | 191.0 | | [Bar chart showing total cycle from 0 to 191s] | | | | | | | | | | | | | | | | | | | | | | | | | | | | | | | | | | | | | |
| Walk Summary (linear feet) | 0 | | | | | | | | | | | | | | | | | | | | | | | | | | | | | | | | | | | | | | | | | | | | | |
| Glue Summary (linear mm) | | 0 | | | | | | | | | | | | | | | | | | | | | | | | | | | | | | | | | | | | | | | | | | | | |
| Friction Str Summary | | | 0 | | | | | | | | | | | | | | | | | | | | | | | | | | | | | | | | | | | | | | | | | | | |
| Hem Summary (linear mm) | | | | 0 | | | | | | | | | | | | | | | | | | | | | | | | | | | | | | | | | | | | | | | | | | |
| MIG Summary (linear mm) | | | | | 0 | | | | | | | | | | | | | | | | | | | | | | | | | | | | | | | | | | | | | | | | | |

Table 2.3.ap: Station FR200 timing sheet

| Description | Walk (feet) | Glue (mm) | FSJ | HEM (mm) | MIG (mm) | start | time (sec) | | seconds | | | | | | | | | | | | | | | | | | | | | | | | | | | | | | | | | | | | | |
|--|-------------|-----------|-----|----------|----------|-------|------------|------|--|----|----|----|----|----|----|----|----|----|----|----|----|----|----|----|----|----|----|-----|-----|-----|-----|-----|-----|-----|-----|-----|-----|-----|-----|-----|-----|-----|-----|-----|-----|-----|
| | | | | | | | Az. | sum | 5 | 10 | 15 | 20 | 25 | 30 | 35 | 40 | 45 | 50 | 55 | 60 | 65 | 70 | 75 | 80 | 85 | 90 | 95 | 100 | 105 | 110 | 115 | 120 | 125 | 130 | 135 | 140 | 145 | 150 | 155 | 160 | 165 | 170 | 175 | 180 | 185 | 190 |
| | | | | | | | | | | | | | | | | | | | | | | | | | | | | | | | | | | | | | | | | | | | | | | |
| Framing (Idle Station) | | | | | | | | | | | | | | | | | | | | | | | | | | | | | | | | | | | | | | | | | | | | | | |
| <i>CYCLE (BELOW) STARTS WITH A COMPLETED CYCLE</i> | | | | | | | | | | | | | | | | | | | | | | | | | | | | | | | | | | | | | | | | | | | | | | |
| 1 Transfer advances asm into Station | | | | | | 0.0 | 13.0 | 13.0 | [Bar chart showing activity from 0 to 13s] | | | | | | | | | | | | | | | | | | | | | | | | | | | | | | | | | | | | | |
| Station Cycle Time | | | | | | 191.0 | 191.0 | | [Bar chart showing total cycle from 0 to 191s] | | | | | | | | | | | | | | | | | | | | | | | | | | | | | | | | | | | | | |
| Walk Summary (linear feet) | 0 | | | | | | | | | | | | | | | | | | | | | | | | | | | | | | | | | | | | | | | | | | | | | |
| Glue Summary (linear mm) | | 0 | | | | | | | | | | | | | | | | | | | | | | | | | | | | | | | | | | | | | | | | | | | | |
| Friction Str Summary | | | 0 | | | | | | | | | | | | | | | | | | | | | | | | | | | | | | | | | | | | | | | | | | | |
| Hem Summary (linear mm) | | | | 0 | | | | | | | | | | | | | | | | | | | | | | | | | | | | | | | | | | | | | | | | | | |
| MIG Summary (linear mm) | | | | | 0 | | | | | | | | | | | | | | | | | | | | | | | | | | | | | | | | | | | | | | | | | |

2.4 Tool Content Per Station

In order to build the Phase 2 HD vehicle, a number of tools are required at each station ranging from the basic loose parts to advanced robots. The tools needed at each station are listed in Tables 2.4.a-2.4.ao below with a summary of all the necessary tools listed in Table 2.4.ap.

Table 2.4.a: Station SA05 tool content

| SA05 | | |
|---|-----------------|--------------------|
| Description | Quantity | Single Hand |
| Loose Parts Load | 10 | |
| Operators | 1 | |
| MIG Weld (value in millimeters) | 1952 | 976 |
| ROBOTS | | |
| 130 kg robot w/ riser, dress, and controller | 1 | |
| JOINING TECHNOLOGY | | |
| MIG head, feeder, and controller | 1 | |
| Power and interface panel -- single door | 1 | |
| 4' wide roll up door | 4 | |
| 4' wide hinged access door | 1 | |
| 60" long by 12" wide sheet metal chute | 2 | |
| Operator palm buttons | 2 | |
| Vent hood | 2 | |
| 4-post base 30" x 60" | 2 | |
| Part present switches | 28 | |
| Round 4-way locating pin w/ adjustment blocks | 8 | |
| Round 2-way locating pin w/ adjustment blocks | 8 | |
| Round 4-way retract locating pin w/ adjustment blocks | 2 | |
| Round 2-way retract locating pin w/ adjustment blocks | 2 | |
| Rectangular locating pin w/ adjustment blocks (inside tube) | 4 | |
| 200mm self-contained indexing slide | 2 | |
| Power clamp units (w/ riser, backup, finger & adjustment) | 16 | |
| Large weldments for slide mounting | 2 | |

| | | |
|----------------|----|--|
| Rough locators | 32 | |
|----------------|----|--|

Table 2.4.b: Station SA10 tool content

| SA10 | | |
|---|-----------------|--------------------|
| Description | Quantity | Single Hand |
| Loose Parts Load | 14 | |
| Operators | 1 | |
| MIG Weld (value in millimeters) | 1213 | 606.5 |
| ROBOTS | | |
| 130 kg robot w/ riser, dress, and controller | 1 | |
| JOINING TECHNOLOGY | | |
| MIG head, feeder, and controller | 1 | |
| Power and interface panel -- single door | 1 | |
| 4' wide roll up door | 4 | |
| 4' wide hinged access door | 1 | |
| 60" long by 12" wide sheet metal chute | 1 | |
| Operator palm buttons | 2 | |
| Perimeter guard (walls/fences) | 1 | |
| 4-post base 30" x 70" | 1 | |
| 4-post base 32" x 32" | 22 | |
| Part present switches | 18 | |
| Round 4-way locating pin w/ adjustment blocks | 6 | |
| Round 2-way locating pin w/ adjustment blocks | 2 | |
| Round 4-way retract locating pin w/ adjustment blocks | 2 | |
| Round 2-way retract locating pin w/ adjustment blocks | 2 | |
| 50mm self-contained indexing slide | 4 | |
| 200mm self-contained indexing slide | 20 | |
| Small weldments for slide mounting | 4 | |
| Large weldments for slide mounting | 38 | |
| 60" wide horizontal lightscreen | 1 | |
| Rest unit (w/ riser, rest blocks and adjustment) | 1 | |

Table 2.4.c: Station SA15 tool content

| SA15 | | |
|---|-----------------|--------------------|
| Description | Quantity | Single Hand |
| Loose Parts Load | 40 | 20 |
| Operators | 1 | |
| Adhesive (value in millimeters) | 4150 | 2075 |
| Self Piercing Rivet Spot | 46 | 23 |
| ROBOTS | | |
| 165 kg robot w/ riser, dress, and controller | 1 | |
| 130 kg robot w/ riser, dress, and controller | 1 | |
| JOINING TECHNOLOGY | | |
| Rivet Head, feeder, and controller | 1 | |
| Adhesive Nozzle, Pump, and Heater | 1 | |
| Power and interface panel -- double door | 1 | |
| 4' wide hinged gate | 1 | |
| Operator palm buttons | 1 | |
| 4-post base 48" x 60" | 4 | |
| Part present switches | 20 | |
| Round 4-way locating pin w/ adjustment blocks | 10 | |
| Round 2-way locating pin w/ adjustment blocks | 10 | |
| 200mm self-contained indexing slide | 4 | |
| Power clamp units (w/ riser, backup, finger & adjustment) | 14 | |
| Large weldments for slide mounting | 1 | |
| Rough locators | 28 | |
| 60" wide horizontal lightscreen | 1 | |
| 84" tall vertical lightscreen | 1 | |
| Large capacity rotate table | 1 | |
| Large frame (mounting to rotate table) | 1 | |
| Rest unit (w/ riser, rest blocks and adjustment) | 4 | |

Table 2.4.d: Station SA20 tool content

| SA20 | | |
|---|-----------------|--------------------|
| Description | Quantity | Single Hand |
| Loose Parts Load | 7 | |
| Operators | 1 | |
| Adhesive (value in millimeters) | 2715 | |
| Rivtac Spots | 28 | |
| ROBOTS | | |
| 165 kg robot w/ riser, dress, and controller | 1 | |
| Tool Changer (robot side) | 1 | |
| Tool Changer (tool side) | 2 | |
| JOINING TECHNOLOGY | | |
| Rivtac Unit, feeder, and controller | 1 | |
| Adhesive Nozzle, Pump, and Heater | 1 | |
| END EFFECTORS | | |
| End effector (medium) | 1 | |
| End effector storage stand | 2 | |
| Power and interface panel -- single door | 1 | |
| Operator palm buttons | 1 | |
| 4-post base 40" x 80" | 2 | |
| Part present switches | 16 | |
| Round 4-way locating pin w/ adjustment blocks | 2 | |
| Round 2-way locating pin w/ adjustment blocks | 1 | |
| Round 4-way retract locating pin w/ adjustment blocks | 2 | |
| Round 2-way retract locating pin w/ adjustment blocks | 2 | |
| Power clamp units (w/ riser, backup, finger & adjustment) | 8 | |
| Rough locators | 30 | |
| 60" wide horizontal lightscreen | 1 | |
| 84" tall vertical lightscreen | 1 | |

Table 2.4.e: Station SA25 tool content

| SA25 | | |
|---|-----------------|--------------------|
| Description | Quantity | Single Hand |
| Loose Parts Load | 32 | |
| Friction Stir Joining | 38 | |
| Operators | 1 | |
| Rivtac Spots | 16 | |
| ROBOTS | | |
| 165 kg robot w/ riser, dress, and controller | 2 | |
| Tool Changer (robot side) | 1 | |
| Tool Changer (tool side) | 2 | |
| JOINING TECHNOLOGY | | |
| FSJ unit with controller | 1 | |
| Rivtac Unit, feeder, and controller | 1 | |
| END EFFECTORS | | |
| End effector (large) | 1 | |
| End effector storage stand | 2 | |
| Operator palm buttons | | |
| Operator palm buttons | 1 | |
| 4-post base 48" x 60" | 1 | |
| Part present switches | 36 | |
| Round 4-way locating pin w/ adjustment blocks | 2 | |
| Round 2-way locating pin w/ adjustment blocks | 2 | |
| Power clamp units (w/ riser, backup, finger & adjustment) | 22 | |
| Rough locators | 36 | |
| 60" wide horizontal lightscreen | | |
| 60" wide horizontal lightscreen | 1 | |
| 84" tall vertical lightscreen | | |
| 84" tall vertical lightscreen | 1 | |
| Staging Table | 1 | |
| Nut runner | 2 | |

Table 2.4.f: Station SA30 tool content

| SA30 | | |
|---|-----------------|--------------------|
| Description | Quantity | Single Hand |
| Loose Parts Load | 4 | |
| Operators | 2 | |
| Operator palm buttons | | |
| Operator palm buttons | 2 | |
| 4-post base 48" x 60" | 1 | |
| Part present switches | 13 | |
| Round 4-way locating pin w/ adjustment blocks | 2 | |
| Round 2-way locating pin w/ adjustment blocks | 2 | |
| Power clamp units (w/ riser, backup, finger & adjustment) | 14 | |
| Rough locators | 16 | |
| 60" wide horizontal lightscreen | | |
| 60" wide horizontal lightscreen | 1 | |
| 84" tall vertical lightscreen | | |
| 84" tall vertical lightscreen | 1 | |
| Rest unit (w/ riser, rest blocks and adjustment) | 8 | |
| Frame for adhesive nozzle mount (pad) | 2 | |
| Nut runner | 2 | |

Table 2.4.g: Station SA35 tool content

| SA35 | | |
|--|-----------------|--------------------|
| Description | Quantity | Single Hand |
| Loose Parts Load | 5 | |
| Friction Stir Joining | 30 | |
| Operators | SHARE | |
| Adhesive (value in millimeters) | 3700 | |
| ROBOTS | | |
| 165 kg robot w/ riser, dress, and controller | 1 | |
| Tool Changer (robot side) | 1 | |
| Tool Changer (tool side) | 2 | |
| JOINING TECHNOLOGY | | |
| FSJ unit with controller | 1 | |

| | | |
|---|----|--|
| Adhesive Nozzle, Pump, and Heater | 1 | |
| END EFFECTORS | | |
| End effector (large) | 1 | |
| End effector storage stand | 2 | |
| Power and interface panel -- single door | | |
| Power and interface panel -- single door | 1 | |
| Operator palm buttons | 1 | |
| 4-post base 40" x 80" | 1 | |
| Part present switches | 8 | |
| Round 4-way locating pin w/ adjustment blocks | 3 | |
| Round 2-way locating pin w/ adjustment blocks | 3 | |
| Round 4-way retract locating pin w/ adjustment blocks | 1 | |
| Round 2-way retract locating pin w/ adjustment blocks | 1 | |
| Power clamp units (w/ riser, backup, finger & adjustment) | 7 | |
| Rough locators | 12 | |
| 60" wide horizontal lightscreen | | |
| 60" wide horizontal lightscreen | 1 | |
| 84" tall vertical lightscreen | | |
| 84" tall vertical lightscreen | 1 | |
| Large frame (mounting to rotate table) | | |
| Large frame (mounting to rotate table) | 1 | |
| Rest unit (w/ riser, rest blocks and adjustment) | | |
| Rest unit (w/ riser, rest blocks and adjustment) | 4 | |
| Pivoting dump (w/ mtg bracket, shocks, stops & cylinder) | | |
| Pivoting dump (w/ mtg bracket, shocks, stops & cylinder) | 1 | |

Table 2.4.h: Station SA40 tool content

| SA40 | | |
|--|-----------------|--------------------|
| Description | Quantity | Single Hand |
| Loose Parts Load | 14 | 7 |
| Operators | 2 | 1 |
| Adhesive (value in millimeters) | 9060 | 4530 |
| Rivtac Spots | 50 | 25 |
| ROBOTS | | |
| 130 kg robot w/ riser, dress, and controller | 4 | |
| JOINING TECHNOLOGY | | |
| Rivtac Unit, feeder, and controller | 2 | |

| | | |
|---|----|--|
| Adhesive Nozzle, Pump, and Heater | 1 | |
| END EFFECTORS | | |
| End effector (large) | 1 | |
| Operator palm buttons | | |
| Operator palm buttons | 1 | |
| Part present switches | 10 | |
| Round 4-way locating pin w/ adjustment blocks | 3 | |
| Round 2-way locating pin w/ adjustment blocks | 3 | |
| Round 4-way retract locating pin w/ adjustment blocks | 4 | |
| Round 2-way retract locating pin w/ adjustment blocks | 4 | |
| 50mm self-contained indexing slide | 4 | |
| 200mm self-contained indexing slide | | |
| Power clamp units (w/ riser, backup, finger & adjustment) | 8 | |
| Small weldments for slide mounting | 4 | |
| Large weldments for slide mounting | | |
| Rough locators | 28 | |
| 60" wide horizontal lightscreen | | |
| 60" wide horizontal lightscreen | 1 | |
| 84" tall vertical lightscreen | | |
| 84" tall vertical lightscreen | 1 | |
| Rest unit (w/ riser, rest blocks and adjustment) | 2 | |
| Large base 70" x 180" | 1 | |
| Pivoting dump (w/ mtg bracket, shocks, stops & cylinder) | 4 | |

Table 2.4.i: Station SA45 tool content

| SA45 | | |
|--|-----------------|--------------------|
| Description | Quantity | Single Hand |
| Loose Parts Load | 8 | 4 |
| Friction Stir Joining | 60 | 30 |
| Operators | 2 | 1 |
| Adhesive (value in millimeters) | 3600 | 1800 |
| ROBOTS | | |
| 165 kg robot w/ riser, dress, and controller | 1 | |
| Tool Changer (robot side) | 1 | |
| Tool Changer (tool side) | 2 | |

| JOINING TECHNOLOGY | | |
|---|----|--|
| FSJ unit with controller | 1 | |
| Adhesive Nozzle, Pump, and Heater | 1 | |
| END EFFECTORS | | |
| End effector (large) | 1 | |
| End effector storage stand | 2 | |
| Power and interface panel -- single door | | |
| Power and interface panel -- single door | 1 | |
| Operator palm buttons | 1 | |
| 4-post base 40" x 80" | 1 | |
| Part present switches | 14 | |
| Round 4-way locating pin w/ adjustment blocks | 1 | |
| Round 2-way locating pin w/ adjustment blocks | 1 | |
| Round 4-way retract locating pin w/ adjustment blocks | 3 | |
| Round 2-way retract locating pin w/ adjustment blocks | 3 | |
| Power clamp units (w/ riser, backup, finger & adjustment) | 8 | |
| Rough locators | 12 | |
| 84" tall vertical lightscreen | | |
| 84" tall vertical lightscreen | 1 | |
| Rest unit (w/ riser, rest blocks and adjustment) | 8 | |
| Frame for adhesive nozzle mount (pad) | 1 | |
| Conveyor (W/pins locators and rests) | 1 | |
| Pivoting dump (w/ mtg bracket, shocks, stops & cylinder) | 1 | |

Table 2.4.j: Station SA50 tool content

| SA50 | | |
|--|-----------------|--------------------|
| Description | Quantity | Single Hand |
| Loose Parts Load | 3 | |
| Operators | SHARE | |
| Adhesive (value in millimeters) | 1710 | |
| Self Piercing Rivet Spot | 22 | |
| ROBOTS | | |
| 165 kg robot w/ riser, dress, and controller | 2 | |
| Tool Changer (robot side) | 1 | |

| | | |
|---|---|--|
| Tool Changer (tool side) | 2 | |
| JOINING TECHNOLOGY | | |
| Rivet Head, feeder, and controller | 2 | |
| Adhesive Nozzle, Pump, and Heater | 1 | |
| END EFFECTORS | | |
| End effector (large) | 1 | |
| End effector storage stand | 2 | |
| Operator palm buttons | 1 | |
| 4-post base 40" x 80" | 1 | |
| Part present switches | 6 | |
| Round 4-way locating pin w/ adjustment blocks | 1 | |
| Round 2-way locating pin w/ adjustment blocks | 1 | |
| Round 4-way retract locating pin w/ adjustment blocks | 2 | |
| Round 2-way retract locating pin w/ adjustment blocks | 2 | |
| Power clamp units (w/ riser, backup, finger & adjustment) | 8 | |
| Rough locators | 8 | |
| 60" wide horizontal lightscreen | 1 | |
| 84" tall vertical lightscreen | 1 | |
| Rest unit (w/ riser, rest blocks and adjustment) | 4 | |
| Frame for adhesive nozzle mount (pad) | 1 | |

Table 2.4.k: Station SA55 tool content

| SA55 | | |
|---------------------------------|-----------------|--------------------|
| Description | Quantity | Single Hand |
| Loose Parts Load | 3 | |
| Operators | SHARE | |
| Adhesive (value in millimeters) | 3600 | |
| Self Piercing Rivet Spot | 46 | |
| Operator palm buttons | 1 | |
| 4-post base 40" x 80" | 1 | |
| Part present switches | 6 | |

| | | |
|---|----|--|
| Round 4-way locating pin w/ adjustment blocks | 2 | |
| Round 2-way locating pin w/ adjustment blocks | 2 | |
| Round 4-way retract locating pin w/ adjustment blocks | 1 | |
| Round 2-way retract locating pin w/ adjustment blocks | 1 | |
| Power clamp units (w/ riser, backup, finger & adjustment) | 8 | |
| Rough locators | 12 | |
| | | |
| Rest unit (w/ riser, rest blocks and adjustment) | 6 | |

Table 2.4.I: Station SA60 tool content

| SA60 | | |
|---|-----------------|--------------------|
| Description | Quantity | Single Hand |
| Loose Parts Load | 6 | |
| Friction Stir Joining | 62 | |
| Operators | 1 | |
| Adhesive (value in millimeters) | 2715 | |
| | | |
| ROBOTS | | |
| 165 kg robot w/ riser, dress, and controller | 2 | |
| Tool Changer (robot side) | 2 | |
| Tool Changer (tool side) | 4 | |
| | | |
| JOINING TECHNOLOGY | | |
| FSJ unit with controller | 2 | |
| Adhesive Nozzle, Pump, and Heater | 1 | |
| | | |
| END EFFECTORS | | |
| End effector (medium) | 2 | |
| End effector storage stand | 4 | |
| | | |
| Operator palm buttons | 1 | |
| 4-post base 48" x 60" | 1 | |
| 4-post base 40" x 80" | 1 | |
| Part present switches | 18 | |
| Round 4-way locating pin w/ adjustment blocks | 6 | |
| Round 2-way locating pin w/ adjustment blocks | 6 | |

| | | |
|---|----|--|
| Power clamp units (w/ riser, backup, finger & adjustment) | 15 | |
| Rough locators | 22 | |
| | | |
| 60" wide horizontal lightscreen | 2 | |
| 84" tall vertical lightscreen | 2 | |
| Rest unit (w/ riser, rest blocks and adjustment) | 8 | |
| Frame for adhesive nozzle mount (pad) | 1 | |
| Conveyor (W/pins locators and rests) | 1 | |

Table 2.4.m: Station SA65 tool content

| SA65 | | |
|--|-----------------|--------------------|
| Description | Quantity | Single Hand |
| Loose Parts Load | 6 | 3 |
| Operators | 2 | 1 |
| Adhesive (value in millimeters) | 2200 | 1100 |
| Self Piercing Rivet Spot | 42 | 21 |
| | | |
| ROBOTS | | |
| 165 kg robot w/ riser, dress, and controller | 1 | |
| Tool Changer (robot side) | 1 | |
| Tool Changer (tool side) | 3 | |
| | | |
| JOINING TECHNOLOGY | | |
| Rivet Head, feeder, and controller | 1 | |
| Adhesive Nozzle, Pump, and Heater | 1 | |
| | | |
| END EFFECTORS | | |
| End effector (small) | | |
| End effector (medium) | 2 | |
| End effector storage stand | 3 | |
| | | |
| Power and interface panel -- single door | 1 | |
| Operator palm buttons | 1 | |
| 4-post base 48" x 60" | 2 | |
| 4-post base 30" x 60" | 1 | |
| Part present switches | 10 | |

| | | |
|---|----|--|
| Round 4-way locating pin w/ adjustment blocks | 1 | |
| Round 2-way locating pin w/ adjustment blocks | 1 | |
| Round 4-way retract locating pin w/ adjustment blocks | 2 | |
| Round 2-way retract locating pin w/ adjustment blocks | 2 | |
| Power clamp units (w/ riser, backup, finger & adjustment) | 8 | |
| Rough locators | 22 | |
| | | |
| 84" tall vertical lightscreen | 1 | |
| Rest unit (w/ riser, rest blocks and adjustment) | 16 | |

Table 2.4.n: Station SA70 tool content

| SA70 | | |
|--|-----------------|--------------------|
| Description | Quantity | Single Hand |
| Loose Parts Load | 18 | 9 |
| Friction Stir Joining | 132 | 66 |
| Operators | 2 | 1 |
| Adhesive (value in millimeters) | 6800 | 3400 |
| Resistance Weld Spots | 76 | 38 |
| | | |
| ROBOTS | | |
| 165 kg robot w/ riser, dress, and controller | 12 | |
| Tool Changer (robot side) | 6 | |
| Tool Changer (tool side) | 12 | |
| | | |
| JOINING TECHNOLOGY | | |
| FSJ unit with controller | 4 | |
| Weld Gun, Weld Timer, Water Saver | 2 | |
| Adhesive Nozzle, Pump, and Heater | 4 | |
| | | |
| END EFFECTORS | | |
| End effector (large) | 6 | |
| End effector storage stand | 12 | |
| | | |
| Power and interface panel -- double door | 4 | |
| 4' wide hinged gate | 4 | |
| Operator palm buttons | 6 | |

| | | |
|--|----|--|
| 4-post base 60" x 120" | 6 | |
| 4-post base 48" x 60" | 6 | |
| Part present switches | 52 | |
| Round 4-way locating pin w/ adjustment blocks | 12 | |
| Round 2-way locating pin w/ adjustment blocks | 12 | |
| Round 4-way retract locating pin w/ adjustment blocks | 14 | |
| Round 2-way retract locating pin w/ adjustment blocks | 14 | |
| Power clamp units (w/ riser, backup, finger & adjustment) | 72 | |
| Rough locators | 84 | |
| | | |
| 60" wide horizontal lightscreen | 8 | |
| 84" tall vertical lightscreen | 10 | |
| Rest unit (w/ riser, rest blocks and adjustment) | 68 | |
| Frame for adhesive nozzle mount (pad) | 4 | |
| Robot mounted camera inspection equipment, with controller | 4 | |
| Overhead rails with balancer | 2 | |

Table 2.4.o: Station SA75 tool content

| SA75 | | |
|--|-----------------|--------------------|
| Description | Quantity | Single Hand |
| Loose Parts Load | 12 | 6 |
| Friction Stir Joining | 46 | 23 |
| Operators | SHARE | 1 |
| Adhesive (value in millimeters) | 1630 | 815 |
| | | |
| ROBOTS | | |
| 130 kg robot w/ riser, dress, and controller | 1 | |
| Tool Changer (robot side) | 2 | |
| Tool Changer (tool side) | 4 | |
| | | |
| JOINING TECHNOLOGY | | |
| FSJ unit with controller | 2 | |
| Adhesive Nozzle, Pump, and Heater | 1 | |
| | | |
| END EFFECTORS | | |
| End effector (medium) | 2 | |

| | | |
|---|----|--|
| End effector storage stand | 4 | |
| | | |
| Operator palm buttons | 1 | |
| 4-post base 30" x 60" | 2 | |
| Part present switches | 10 | |
| Round 4-way locating pin w/ adjustment blocks | 5 | |
| Round 2-way locating pin w/ adjustment blocks | 5 | |
| Power clamp units (w/ riser, backup, finger & adjustment) | 5 | |
| Rough locators | 12 | |
| | | |
| 60" wide horizontal lightscreen | 1 | |
| 84" tall vertical lightscreen | 1 | |
| Rest unit (w/ riser, rest blocks and adjustment) | 8 | |
| Frame for adhesive nozzle mount (pad) | 1 | |

Table 2.4.p: Station SA80 tool content

| SA80 | | |
|--|-----------------|--------------------|
| Description | Quantity | Single Hand |
| Loose Parts Load | 10 | 5 |
| Friction Stir Joining | 24 | 12 |
| Operators | 1 | 1 |
| Adhesive (value in millimeters) | 1742 | 871 |
| | | |
| ROBOTS | | |
| 165 kg robot w/ riser, dress, and controller | 1 | |
| Tool Changer (robot side) | 1 | |
| Tool Changer (tool side) | 2 | |
| | | |
| JOINING TECHNOLOGY | | |
| FSJ unit with controller | 1 | |
| Adhesive Nozzle, Pump, and Heater | 1 | |
| | | |
| END EFFECTORS | | |
| End effector (medium) | 1 | |
| End effector (large) | 1 | |
| End effector storage stand | 2 | |

| | | |
|---|----|--|
| Power and interface panel -- single door | 1 | |
| Operator palm buttons | 1 | |
| 4-post base 48" x 60" | 2 | |
| 4-post base 30" x 60" | 1 | |
| Part present switches | 8 | |
| Round 4-way locating pin w/ adjustment blocks | 1 | |
| Round 2-way locating pin w/ adjustment blocks | 1 | |
| Round 4-way retract locating pin w/ adjustment blocks | 3 | |
| Round 2-way retract locating pin w/ adjustment blocks | 3 | |
| 50mm self-contained indexing slide | 2 | |
| 200mm self-contained indexing slide | 1 | |
| Power clamp units (w/ riser, backup, finger & adjustment) | 8 | |
| Rough locators | 22 | |
| | | |
| 84" tall vertical lightscreen | 1 | |
| Rest unit (w/ riser, rest blocks and adjustment) | 16 | |
| Frame for adhesive nozzle mount (pad) | 1 | |
| Conveyor (W/pins locators and rests) | 1 | |

Table 2.4.q: Station SA85 tool content

| SA85 | | |
|--|-----------------|--------------------|
| Description | Quantity | Single Hand |
| Loose Parts Load | 8 | 4 |
| Operators | 1 | |
| Resistance Weld Spots | 32 | 16 |
| | | |
| ROBOTS | | |
| 165 kg robot w/ riser, dress, and controller | 1 | |
| | | |
| JOINING TECHNOLOGY | | |
| Weld Gun, Weld Timer, Water Saver | 1 | |
| | | |
| Power and interface panel -- single door | 1 | |
| 4' wide hinged gate | 1 | |
| Operator palm buttons | 1 | |

| | | |
|---|----|--|
| 4-post base 30" x 60" | 1 | |
| Part present switches | 8 | |
| Round 4-way locating pin w/ adjustment blocks | 4 | |
| Round 2-way locating pin w/ adjustment blocks | 4 | |
| Power clamp units (w/ riser, backup, finger & adjustment) | 8 | |
| Rough locators | 16 | |
| | | |
| 60" wide horizontal lightscreen | 1 | |
| 84" tall vertical lightscreen | 1 | |
| Rest unit (w/ riser, rest blocks and adjustment) | 4 | |

Table 2.4.r: Station UB100 tool content

| UB100 | | |
|---|-----------------|--------------------|
| Description | Quantity | Single Hand |
| Loose Parts Load | 5 | |
| Operators | SHARE | |
| | | |
| ROBOTS | | |
| 165 kg robot w/ riser, dress, and controller | 1 | |
| Robot 7th Axis Slide | 1 | |
| | | |
| JOINING TECHNOLOGY | | |
| End effector (large) | 2 | |
| | | |
| Operator palm buttons | 1 | |
| Part present switches | 10 | |
| Round 4-way locating pin w/ adjustment blocks | 2 | |
| Round 2-way locating pin w/ adjustment blocks | 2 | |
| Round 4-way retract locating pin w/ adjustment blocks | 3 | |
| Round 2-way retract locating pin w/ adjustment blocks | 3 | |
| Power clamp units (w/ riser, backup, finger & adjustment) | 16 | |
| Large weldments for slide mounting | 4 | |
| Rough locators | 16 | |
| | | |
| Rest unit (w/ riser, rest blocks and adjustment) | 16 | |
| Large base 70" x 180" | 1 | |

| | | |
|--|---|--|
| Pivoting dump (w/ mtg bracket, shocks, stops & cylinder) | 2 | |
|--|---|--|

Table 2.4.s: Station UB110 tool content

| UB110 | | |
|---|-----------------|--------------------|
| Description | Quantity | Single Hand |
| Operators | 0 | |
| Friction Stir Joining | 36 | |
| Adhesive (value in millimeters) | 2650 | |
| ROBOTS | | |
| 165 kg robot w/ riser, dress, and controller | 4 | |
| Tool Changer (robot side) | 2 | |
| Tool Changer (tool side) | 4 | |
| JOINING TECHNOLOGY | | |
| Rivet Head, feeder, and controller | 2 | |
| FSJ unit with controller | 1 | |
| Adhesive Nozzle, Pump, and Heater | 1 | |
| END EFFECTORS | | |
| End effector (small) | | |
| End effector (medium) | 3 | |
| End effector (large) | | |
| End effector storage stand | 4 | |
| Power and interface panel -- double door | 1 | |
| Part present switches | 10 | |
| Round 4-way locating pin w/ adjustment blocks | 5 | |
| Round 2-way locating pin w/ adjustment blocks | 5 | |
| Power clamp units (w/ riser, backup, finger & adjustment) | 22 | |
| Rest unit (w/ riser, rest blocks and adjustment) | 6 | |
| Large base 70" x 180" | 1 | |

Table 2.4.t: Station UB120 tool content

| UB 120 | | |
|---|-----------------|--------------------|
| Description | Quantity | Single Hand |
| Loose Parts Load | 5 | |
| Operators | 0 | |
| Friction Stir Joining | 40 | |
| Adhesive (value in millimeters) | 11300 | |
| Rivtac Spots | 14 | |
| Self Piercing Rivet Spot | 60 | |
| ROBOTS | | |
| 165 kg robot w/ riser, dress, and controller | 4 | |
| Tool Changer (robot side) | 4 | |
| Tool Changer (tool side) | 8 | |
| JOINING TECHNOLOGY | | |
| Rivet Head, feeder, and controller | 2 | |
| FSJ unit with controller | 2 | |
| Adhesive Nozzle, Pump, and Heater | 2 | |
| END EFFECTORS | | |
| End effector (medium) | 4 | |
| End effector storage stand | 8 | |
| Part Presenters | | |
| Part present switches | 12 | |
| Round 4-way locating pin w/ adjustment blocks | 3 | |
| Round 2-way locating pin w/ adjustment blocks | 3 | |
| Round 4-way retract locating pin w/ adjustment blocks | 3 | |
| Round 2-way retract locating pin w/ adjustment blocks | 3 | |
| Power clamp units (w/ riser, backup, finger & adjustment) | 26 | |
| Other Equipment | | |
| 84" tall vertical lightscreen | 1 | |
| Rest unit (w/ riser, rest blocks and adjustment) | 8 | |
| Large base 70" x 180" | 1 | |

Table 2.4.u: Station UB130 tool content

| UB130 | | |
|---|-----------------|--------------------|
| Description | Quantity | Single Hand |
| Operators | 0 | |
| Part present switches | 2 | |
| Round 4-way locating pin w/ adjustment blocks | 1 | |
| Round 2-way locating pin w/ adjustment blocks | 1 | |
| Power clamp units (w/ riser, backup, finger & adjustment) | 4 | |
| Rough locators | 6 | |
| | | |
| Large base 70" x 180" | 1 | |

Table 2.4.v: Station UB140 tool content

| UB140 | | |
|---|-----------------|--------------------|
| Description | Quantity | Single Hand |
| Operators | 0 | |
| Friction Stir Joining | 140 | 70 |
| | | |
| ROBOTS | | |
| 165 kg robot w/ riser, dress, and controller | 4 | |
| | | |
| JOINING TECHNOLOGY | | |
| FSJ unit with controller | 4 | |
| | | |
| Part present switches | 2 | |
| Round 4-way locating pin w/ adjustment blocks | 1 | |
| Round 2-way locating pin w/ adjustment blocks | 1 | |
| Power clamp units (w/ riser, backup, finger & adjustment) | 4 | |
| Rough locators | 6 | |
| | | |
| Large base 70" x 180" | 1 | |

Table 2.4.w: Station UB150 tool content

| UB150 | | |
|---|-----------------|--------------------|
| Description | Quantity | Single Hand |
| Loose Parts Load | 3 | |
| Operators | 0 | |
| Friction Stir Joining | 52 | 26 |
| Adhesive (value in millimeters) | 5850 | |
| Rivtac Spots | 44 | 22 |
| ROBOTS | | |
| 165 kg robot w/ riser, dress, and controller | 4 | |
| Tool Changer (robot side) | 2 | |
| Tool Changer (tool side) | 6 | |
| JOINING TECHNOLOGY | | |
| Rivet Head, feeder, and controller | 2 | |
| FSJ unit with controller | 2 | |
| Adhesive Nozzle, Pump, and Heater | 2 | |
| END EFFECTORS | | |
| End effector (medium) | 3 | |
| End effector storage stand | 6 | |
| Part present switches | 8 | |
| Round 4-way locating pin w/ adjustment blocks | 3 | |
| Round 2-way locating pin w/ adjustment blocks | 3 | |
| Round 4-way retract locating pin w/ adjustment blocks | 2 | |
| Round 2-way retract locating pin w/ adjustment blocks | 2 | |
| Power clamp units (w/ riser, backup, finger & adjustment) | 27 | |
| Rest unit (w/ riser, rest blocks and adjustment) | 2 | |
| Large base 70" x 180" | 1 | |

Table 2.4.x: Station UB160 tool content

| UB160 | | |
|---|-----------------|--------------------|
| Description | Quantity | Single Hand |
| Operators | 0 | |
| Part present switches | 2 | |
| Round 4-way locating pin w/ adjustment blocks | 1 | |
| Round 2-way locating pin w/ adjustment blocks | 1 | |
| Power clamp units (w/ riser, backup, finger & adjustment) | 4 | |
| Rough locators | 6 | |
| | | |
| Large base 70" x 180" | 1 | |

Table 2.4.y: Station UB170 tool content

| UB170 | | |
|--|-----------------|--------------------|
| Description | Quantity | Single Hand |
| Loose Parts Load | 6 | |
| Operators | 0 | |
| Friction Stir Joining | 76 | |
| Adhesive (value in millimeters) | 16500 | |
| | | |
| ROBOTS | | |
| 165 kg robot w/ riser, dress, and controller | 4 | |
| Tool Changer (robot side) | 4 | |
| Tool Changer (tool side) | 9 | |
| | | |
| JOINING TECHNOLOGY | | |
| Rivet Head, feeder, and controller | 2 | |
| FSJ unit with controller | 2 | |
| Adhesive Nozzle, Pump, and Heater | 2 | |
| | | |
| END EFFECTORS | | |
| End effector (small) | 2 | |
| End effector (medium) | 2 | |
| End effector storage stand | 9 | |
| | | |

| | | |
|---|----|--|
| Part present switches | 14 | |
| Round 4-way locating pin w/ adjustment blocks | 5 | |
| Round 2-way locating pin w/ adjustment blocks | 5 | |
| Round 4-way retract locating pin w/ adjustment blocks | 2 | |
| Round 2-way retract locating pin w/ adjustment blocks | 2 | |
| Power clamp units (w/ riser, backup, finger & adjustment) | 32 | |
| | | |
| Rest unit (w/ riser, rest blocks and adjustment) | 10 | |
| Large base 70" x 180" | 1 | |
| Pivoting dump (w/ mtg bracket, shocks, stops & cylinder | 4 | |

Table 2.4.z: Station UB180 tool content

| UB180 | | |
|---|-----------------|--------------------|
| Description | Quantity | Single Hand |
| Loose Parts Load | 2 | |
| Operators | 0 | |
| Adhesive (value in millimeters) | 6600 | |
| Flow Screw | 8 | |
| | | |
| ROBOTS | | |
| 165 kg robot w/ riser, dress, and controller | 1 | |
| 130 kg robot w/ riser, dress, and controller | 1 | |
| | | |
| JOINING TECHNOLOGY | | |
| Adhesive Nozzle, Pump, and Heater | 1 | |
| | | |
| END EFFECTORS | | |
| End effector (large) | 1 | |
| | | |
| Part present switches | 6 | |
| Round 4-way locating pin w/ adjustment blocks | 3 | |
| Round 2-way locating pin w/ adjustment blocks | 3 | |
| Round 4-way retract locating pin w/ adjustment blocks | 2 | |
| Round 2-way retract locating pin w/ adjustment blocks | 2 | |
| Power clamp units (w/ riser, backup, finger & adjustment) | 20 | |

| | | |
|---|---|--|
| Rest unit (w/ riser, rest blocks and adjustment) | 2 | |
| Large base 70" x 180" | 1 | |
| Pivoting dump (w/ mtg bracket, shocks, stops & cylinder) | 6 | |
| Robot mounted screw head driver, with feeder and controller | 1 | |

Table 2.4.aa: Station UB190 tool content

| UB190 | | |
|---|-----------------|--------------------|
| Description | Quantity | Single Hand |
| Loose Parts Load | 4 | |
| Friction Stir Joining | 42 | |
| Operators | 0 | |
| Adhesive (value in millimeters) | 9800 | |
| Rivtac Spots | 44 | |
| ROBOTS | | |
| 165 kg robot w/ riser, dress, and controller | 4 | |
| Tool Changer (robot side) | 4 | |
| Tool Changer (tool side) | 8 | |
| JOINING TECHNOLOGY | | |
| FSJ unit with controller | 2 | |
| Rivtac Unit, feeder, and controller | 2 | |
| Adhesive Nozzle, Pump, and Heater | 2 | |
| END EFFECTORS | | |
| End effector (small) | 2 | |
| End effector (medium) | 1 | |
| End effector storage stand | 8 | |
| Part present switches | 10 | |
| Round 4-way locating pin w/ adjustment blocks | 3 | |
| Round 2-way locating pin w/ adjustment blocks | 3 | |
| Round 4-way retract locating pin w/ adjustment blocks | 2 | |
| Round 2-way retract locating pin w/ adjustment blocks | 2 | |

| | | |
|---|----|--|
| Power clamp units (w/ riser, backup, finger & adjustment) | 20 | |
| | | |
| Rest unit (w/ riser, rest blocks and adjustment) | 2 | |
| Large base 70" x 180" | 1 | |
| Pivoting dump (w/ mtg bracket, shocks, stops & cylinder) | 6 | |

Table 2.4.ab: Station UB200 tool content

| UB200 | | |
|---|-----------------|--------------------|
| Description | Quantity | Single Hand |
| Friction Stir Joining | 140 | 70 |
| Operators | 0 | |
| | | |
| ROBOTS | | |
| 165 kg robot w/ riser, dress, and controller | 4 | |
| | | |
| JOINING TECHNOLOGY | | |
| FSJ unit with controller | 4 | |
| | | |
| 4-post base 60" x 120" | 1 | |
| Part present switches | 2 | |
| Round 4-way locating pin w/ adjustment blocks | 1 | |
| Round 2-way locating pin w/ adjustment blocks | 1 | |
| Power clamp units (w/ riser, backup, finger & adjustment) | 4 | |
| Rough locators | 6 | |

Table 2.4.ac: Station UB210 tool content

| UB210 | | |
|--|-----------------|--------------------|
| Description | Quantity | Single Hand |
| Operators | 0 | |
| Clinch Studs | 100 | |
| | | |
| ROBOTS | | |
| 130 kg robot w/ riser, dress, and controller | 4 | |
| | | |
| 4-post base 60" x 120" | 1 | |

| | | |
|---|---|--|
| Part present switches | 2 | |
| Round 4-way locating pin w/ adjustment blocks | 1 | |
| Round 2-way locating pin w/ adjustment blocks | 1 | |
| Power clamp units (w/ riser, backup, finger & adjustment) | 4 | |
| Rough locators | 6 | |
| | | |
| Clinch Stud Head, Feeder and Controller | 4 | |

Table 2.4.ad: Station UB220 tool content

| UB220 | | |
|--|-----------------|--------------------|
| Description | Quantity | Single Hand |
| Operators | 0 | |
| Camera Inspection Points | 100 | 50 |
| | | |
| ROBOTS | | |
| 130 kg robot w/ riser, dress, and controller | 2 | |
| | | |
| Part present switches | 2 | |
| Round 4-way locating pin w/ adjustment blocks | 1 | |
| Round 2-way locating pin w/ adjustment blocks | 1 | |
| Power clamp units (w/ riser, backup, finger & adjustment) | 4 | |
| Rough locators | 6 | |
| | | |
| Large base 70" x 180" | 1 | |
| Robot mounted camera inspection equipment, with controller | 2 | |

Table 2.4.ae: Station FR100 tool content

| FR100 | | |
|---|-----------------|--------------------|
| Description | Quantity | Single Hand |
| Operators | 0 | |
| Part present switches | 2 | |
| Round 4-way locating pin w/ adjustment blocks | 1 | |
| Round 2-way locating pin w/ adjustment blocks | 1 | |
| Power clamp units (w/ riser, backup, finger & adjustment) | 4 | |
| Rough locators | 6 | |

| | | |
|-----------------------|---|--|
| | | |
| Large base 70" x 180" | 1 | |

Table 2.4.af: Station FR110 tool content

| FR110 | | |
|---|-----------------|--------------------|
| Description | Quantity | Single Hand |
| Loose Parts Load | 5 | |
| Friction Stir Joining | 100 | 50 |
| Operators | 1 | |
| Adhesive (value in millimeters) | 7000 | 3500 |
| Rivtac Spots | 50 | 25 |
| ROBOTS | | |
| 165 kg robot w/ riser, dress, and controller | 8 | |
| Tool Changer (robot side) | 1 | |
| Tool Changer (tool side) | 2 | |
| Robot 7th Axis Slide | 2 | |
| JOINING TECHNOLOGY | | |
| FSJ unit with controller | 4 | |
| Rivtac Unit, feeder, and controller | 2 | |
| Adhesive Nozzle, Pump, and Heater | 2 | |
| END EFFECTORS | | |
| End effector (large) | 2 | |
| End effector storage stand | 4 | |
| | | |
| Part present switches | 12 | |
| Round 4-way locating pin w/ adjustment blocks | 4 | |
| Round 2-way locating pin w/ adjustment blocks | 4 | |
| Round 4-way retract locating pin w/ adjustment blocks | 2 | |
| Round 2-way retract locating pin w/ adjustment blocks | 2 | |
| 200mm self-contained indexing slide | 6 | |
| Power clamp units (w/ riser, backup, finger & adjustment) | 35 | |
| Rough locators | 12 | |

| | | |
|--|----|--|
| Rest unit (w/ riser, rest blocks and adjustment) | 12 | |
| Frame for adhesive nozzle mount (pad) | 2 | |
| Large base 70" x 180" | 1 | |
| Pivoting dump (w/ mtg bracket, shocks, stops & cylinder) | 6 | |

Table 2.4.ag: Station FR120 tool content

| FR120 | | |
|---|-----------------|--------------------|
| Description | Quantity | Single Hand |
| Friction Stir Joining | 100 | 50 |
| Operators | 0 | |
| ROBOTS | | |
| 165 kg robot w/ riser, dress, and controller | 4 | |
| JOINING TECHNOLOGY | | |
| FSJ unit with controller | 4 | |
| Part present switches | 2 | |
| Round 4-way locating pin w/ adjustment blocks | 1 | |
| Round 2-way locating pin w/ adjustment blocks | 1 | |
| Power clamp units (w/ riser, backup, finger & adjustment) | 4 | |
| Rough locators | 6 | |
| Large base 70" x 180" | 1 | |

Table 2.4.ah: Station FR130 tool content

| FR130 | | |
|--|-----------------|--------------------|
| Description | Quantity | Single Hand |
| Operators | 0 | |
| Clinch Studs | 100 | 50 |
| ROBOTS | | |
| 130 kg robot w/ riser, dress, and controller | 4 | |

| | | |
|---|---|--|
| 4-post base 60" x 120" | 1 | |
| Part present switches | 2 | |
| Round 4-way locating pin w/ adjustment blocks | 1 | |
| Round 2-way locating pin w/ adjustment blocks | 1 | |
| Power clamp units (w/ riser, backup, finger & adjustment) | 4 | |
| Rough locators | 6 | |
| | | |
| Clinch Stud Head, Feeder and Controller | 4 | |

Table 2.4.ai: Station FR140 tool content

| FR140 | | |
|---|-----------------|--------------------|
| Description | Quantity | Single Hand |
| Loose Parts Load | 2 | |
| Friction Stir Joining | 100 | 50 |
| Operators | 0 | |
| Adhesive (value in millimeters) | 4400 | 2200 |
| | | |
| ROBOTS | | |
| 165 kg robot w/ riser, dress, and controller | 6 | |
| Robot 7th Axis Slide | 2 | |
| | | |
| JOINING TECHNOLOGY | | |
| FSJ unit with controller | 4 | |
| Adhesive Nozzle, Pump, and Heater | 2 | |
| | | |
| END EFFECTORS | | |
| End effector (large) | 2 | |
| | | |
| Part present switches | 6 | |
| Round 4-way locating pin w/ adjustment blocks | 1 | |
| Round 2-way locating pin w/ adjustment blocks | 1 | |
| Round 4-way retract locating pin w/ adjustment blocks | 2 | |
| Round 2-way retract locating pin w/ adjustment blocks | 2 | |
| Power clamp units (w/ riser, backup, finger & adjustment) | 28 | |
| | | |

| | | |
|--|---|--|
| Rest unit (w/ riser, rest blocks and adjustment) | 6 | |
| Frame for adhesive nozzle mount (pad) | 2 | |
| Large base 70" x 180" | 1 | |
| Pivoting dump (w/ mtg bracket, shocks, stops & cylinder) | 6 | |

Table 2.4.aj: Station FR150 tool content

| FR150 | | |
|---|-----------------|--------------------|
| Description | Quantity | Single Hand |
| Loose Parts Load | 4 | |
| Friction Stir Joining | 94 | 47 |
| Operators | 1 | |
| Adhesive (value in millimeters) | 16816 | |
| Self Piercing Rivet Spot | 70 | 35 |
| ROBOTS | | |
| 165 kg robot w/ riser, dress, and controller | 5 | |
| Robot 7th Axis Slide | 1 | |
| JOINING TECHNOLOGY | | |
| Rivet Head, feeder, and controller | 2 | |
| FSJ unit with controller | 2 | |
| Adhesive Nozzle, Pump, and Heater | 2 | |
| END EFFECTORS | | |
| End effector (large) | 1 | |
| Part present switches | 8 | |
| Round 4-way locating pin w/ adjustment blocks | 1 | |
| Round 2-way locating pin w/ adjustment blocks | 1 | |
| Round 4-way retract locating pin w/ adjustment blocks | 3 | |
| Round 2-way retract locating pin w/ adjustment blocks | 3 | |
| Power clamp units (w/ riser, backup, finger & adjustment) | 35 | |
| Rest unit (w/ riser, rest blocks and adjustment) | 5 | |
| Frame for adhesive nozzle mount (pad) | 2 | |
| Large base 70" x 180" | 1 | |

| | | |
|---|---|--|
| Pivoting dump (w/ mtg bracket, shocks, stops & cylinder | 6 | |
|---|---|--|

Table 2.4.ak: Station FR160 tool content

| FR160 | | |
|---|-----------------|--------------------|
| Description | Quantity | Single Hand |
| Friction Stir Joining | 140 | 70 |
| Operators | 0 | |
| ROBOTS | | |
| 165 kg robot w/ riser, dress, and controller | 4 | |
| JOINING TECHNOLOGY | | |
| FSJ unit with controller | 4 | |
| Part present switches | 2 | |
| Round 4-way locating pin w/ adjustment blocks | 1 | |
| Round 2-way locating pin w/ adjustment blocks | 1 | |
| Power clamp units (w/ riser, backup, finger & adjustment) | 4 | |
| Rough locators | 6 | |
| Large base 70" x 180" | 1 | |

Table 2.4.al: Station FR170 tool content

| FR170 | | |
|---|-----------------|--------------------|
| Description | Quantity | Single Hand |
| Operators | 0 | |
| Camera Inspection Points | 100 | 50 |
| ROBOTS | | |
| 130 kg robot w/ riser, dress, and controller | 2 | |
| Part present switches | 2 | |
| Round 4-way locating pin w/ adjustment blocks | 1 | |
| Round 2-way locating pin w/ adjustment blocks | 1 | |
| Power clamp units (w/ riser, backup, finger & adjustment) | 4 | |

| | | |
|--|---|--|
| Rough locators | 6 | |
| | | |
| Large base 70" x 180" | 1 | |
| Robot mounted camera inspection equipment, with controller | 2 | |

Table 2.4.am: Station FR180 tool content

| FR180 | | |
|---|-----------------|--------------------|
| Description | Quantity | Single Hand |
| Loose Parts Load | 3 | |
| Operators | 2 | |
| | | |
| Operator palm buttons | 2 | |
| Part present switches | 2 | |
| Round 4-way locating pin w/ adjustment blocks | 1 | |
| Round 2-way locating pin w/ adjustment blocks | 1 | |
| Power clamp units (w/ riser, backup, finger & adjustment) | 4 | |
| Rough locators | 12 | |
| | | |
| Large base 70" x 180" | 1 | |
| Nut runner | 4 | |
| Load Assist | 2 | |
| Operator Platform (10' x 20') | 2 | |
| Overhead rails with balancer | 2 | |

Table 2.4.an: Station FR190 tool content

| FR190 | | |
|---|-----------------|--------------------|
| Description | Quantity | Single Hand |
| Operators | 2 | |
| | | |
| Part present switches | 2 | |
| Round 4-way locating pin w/ adjustment blocks | 1 | |
| Round 2-way locating pin w/ adjustment blocks | 1 | |
| Power clamp units (w/ riser, backup, finger & adjustment) | 4 | |
| Rough locators | 6 | |
| | | |

| | | |
|-------------------------------|---|--|
| Large base 70" x 180" | 1 | |
| Operator Platform (10' x 20') | 2 | |

Table 2.4.ao: Station FR200 tool content

| FR200 | | |
|---|-----------------|--------------------|
| Description | Quantity | Single Hand |
| Operators | 0 | |
| Part present switches | 2 | |
| Round 4-way locating pin w/ adjustment blocks | 1 | |
| Round 2-way locating pin w/ adjustment blocks | 1 | |
| Power clamp units (w/ riser, backup, finger & adjustment) | 4 | |
| Rough locators | 6 | |
| Large base 70" x 180" | 1 | |

Table 2.4.ap: Total station tool content

| Total | |
|--|-----------------|
| Description | Quantity |
| Loose Parts Load | 239 |
| Friction Stir Joining | 1452 |
| Operators | 24 |
| Adhesive (value in millimeters) | 124538 |
| Clinch Studs | 200 |
| Resistance Weld Spots | 108 |
| Rivtac Spots | 246 |
| Self Piercing Rivet Spot | 286 |
| Flow Screw | 8 |
| MIG Weld (value in millimeters) | 3165 |
| Camera Inspection Points | 200 |
| ROBOTS | |
| 165 kg robot w/ riser, dress, and controller | 82 |
| 130 kg robot w/ riser, dress, and controller | 21 |
| Tool Changer (robot side) | 34 |
| Tool Changer (tool side) | 72 |
| Robot 7th Axis Slide | 6 |

| JOINING TECHNOLOGY | |
|---|-----|
| Rivet Head, feeder, and controller | 14 |
| FSJ unit with controller | 47 |
| Rivtac Unit, feeder, and controller | 8 |
| MIG head, feeder, and controller | 2 |
| Weld Gun, Weld Timer, Water Saver | 3 |
| Adhesive Nozzle, Pump, and Heater | 30 |
| END EFFECTORS | |
| End effector (small) | 4 |
| End effector (medium) | 21 |
| End effector (large) | 20 |
| End effector storage stand | 74 |
| Power and interface panel -- single door | 8 |
| Power and interface panel -- double door | 6 |
| 4' wide roll up door | 8 |
| 4' wide hinged access door | 2 |
| 4' wide hinged gate | 6 |
| 60" long by 12" wide sheet metal chute | 3 |
| Operator palm buttons | 28 |
| Perimeter guard (walls/fences) | 1 |
| Vent hood | 2 |
| 4-post base 60" x 120" | 9 |
| 4-post base 48" x 60" | 17 |
| 4-post base 40" x 80" | 7 |
| 4-post base 30" x 60" | 7 |
| 4-post base 30" x 70" | 1 |
| 4-post base 32" x 32" | 22 |
| Part present switches | 405 |
| Round 4-way locating pin w/ adjustment blocks | 113 |
| Round 2-way locating pin w/ adjustment blocks | 108 |
| Round 4-way retract locating pin w/ adjustment blocks | 57 |
| Round 2-way retract locating pin w/ adjustment blocks | 57 |
| Rectangular locating pin w/ adjustment blocks (inside tube) | 4 |
| 50mm self-contained indexing slide | 10 |
| 200mm self-contained indexing slide | 33 |

| | |
|---|-----|
| Power clamp units (w/ riser, backup, finger & adjustment) | 546 |
| Small weldments for slide mounting | 8 |
| Large weldments for slide mounting | 45 |
| Rough locators | 510 |
| | |
| 60" wide horizontal lightscreen | 20 |
| 84" tall vertical lightscreen | 25 |
| Large capacity rotate table | 1 |
| Large frame (mounting to rotate table) | 2 |
| Rest unit (w/ riser, rest blocks and adjustment) | 226 |
| Staging Table | 1 |
| Frame for adhesive nozzle mount (pad) | 17 |
| Conveyor (W/pins locators and rests) | 3 |
| Large base 70" x 180" | 22 |
| Pivoting dump (w/ mtg bracket, shocks, stops & cylinder) | 42 |
| Nut runner | 8 |
| Load Assist | 2 |
| Clinch Stud Head, Feeder and Controller | 8 |
| Operator Platform (10' x 20') | 4 |
| Robot mounted camera inspection equipment, with controller | 8 |
| Overhead rails with balancer | 4 |
| Robot mounted screw head driver, with feeder and controller | 1 |

2.5 Conveyor Concept

There are a total of five different conveyors in the factory – one each for the sub-assemblies, underbody line, the cross transport, framing line, and after the framing line, which isn't included in this study.

2.5.1 Sub-Assemblies

There are two methods of transport on the sub-assembly conveyor line. The parts are loaded onto the actual conveyor belt by robots or human operators. Once on the assembly line, the parts are handled by robots.

2.5.2 Underbody Line

Like the sub-assembly line, there are two methods of transport on the underbody line. Parts are loaded onto the line by robots and transferred by forklifts.

2.5.3 Cross Transport

One primary method of transportation will be used to transport the fully-built underbodies to the framing line. The underbodies will be loaded onto pallets and transported on a conveyor belt to the framing line (2.5.4 below). These pallets are used on the framing line as well. An elevator and overhead return recycle the pallets and are further discussed in 2.5.4 below.

2.5.4 Framing Line

The underbodies remain on the pallets used in the cross transport process and are moved along the framing line by power rollers. A total of 50 pallets are used in the system. Once framing is complete, the assembled frames are removed and the pallets are lifted up to an overhead return line by an elevator. A second elevator just before the cross transport line lowers the pallets back to the cross transport line.

2.5.5 After Framing Line

After the framing line, there is an elevator to raise the fully-built BIWs to an electric motorized system for further vehicle buildup. This was not included in the scope of this manufacturing study.

2.6 Buffer Concept

In order to help prevent assembly line delays, each of the main lines will be disconnected with buffers. A maximum buffer of 10 parts, roughly 32 minutes worth of production, will help to prevent any delays. The buffer is designed to be approximately half full on average as this allows the worker to fill the buffer up when production after the buffer halts and to empty it when production prior to the buffer stops.

2.7 Station Layouts

This section provides a detailed layout of each assembly station at the plant in Figures 2.7.a-2.7.as with a full plant overview in Figure 2.7.at. All the necessary bins, racks, parts, machinery, conveyors, and workers are shown.

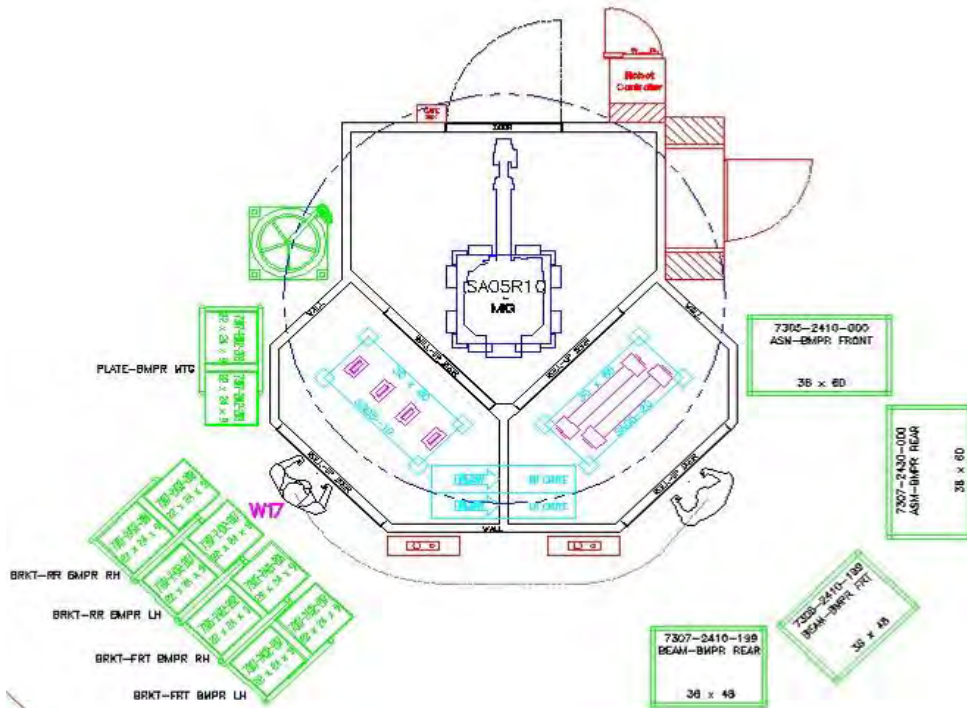

Figure 2.7.a: Station SA05 layout

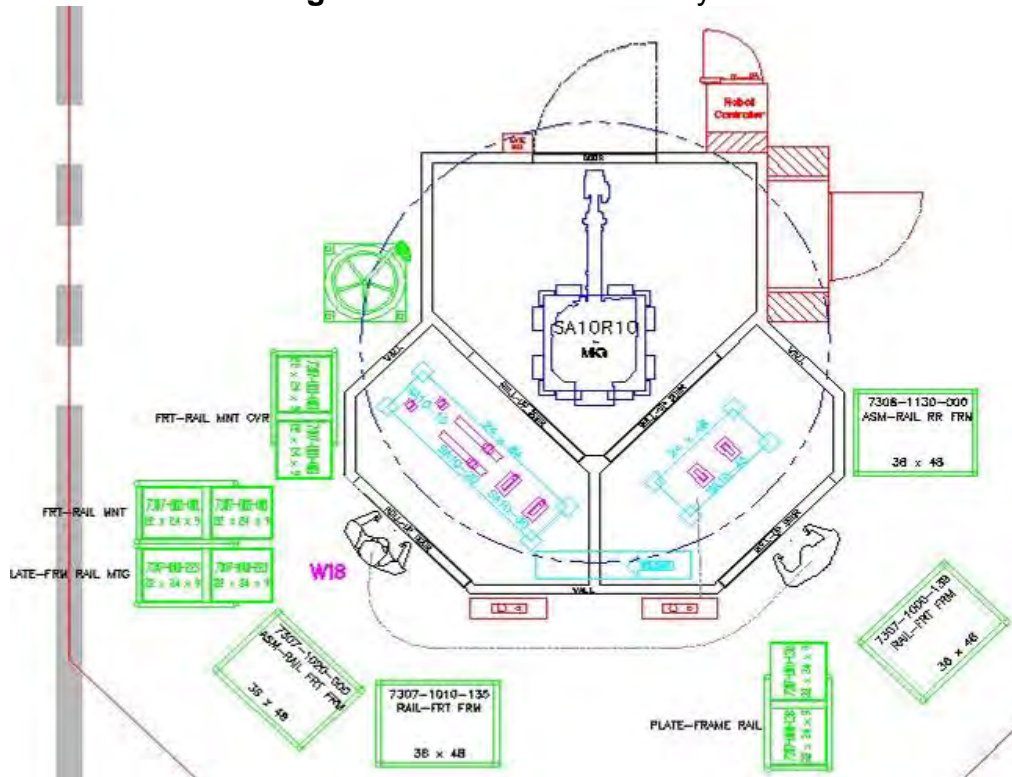

Figure 2.7.b: Station SA 10 layout

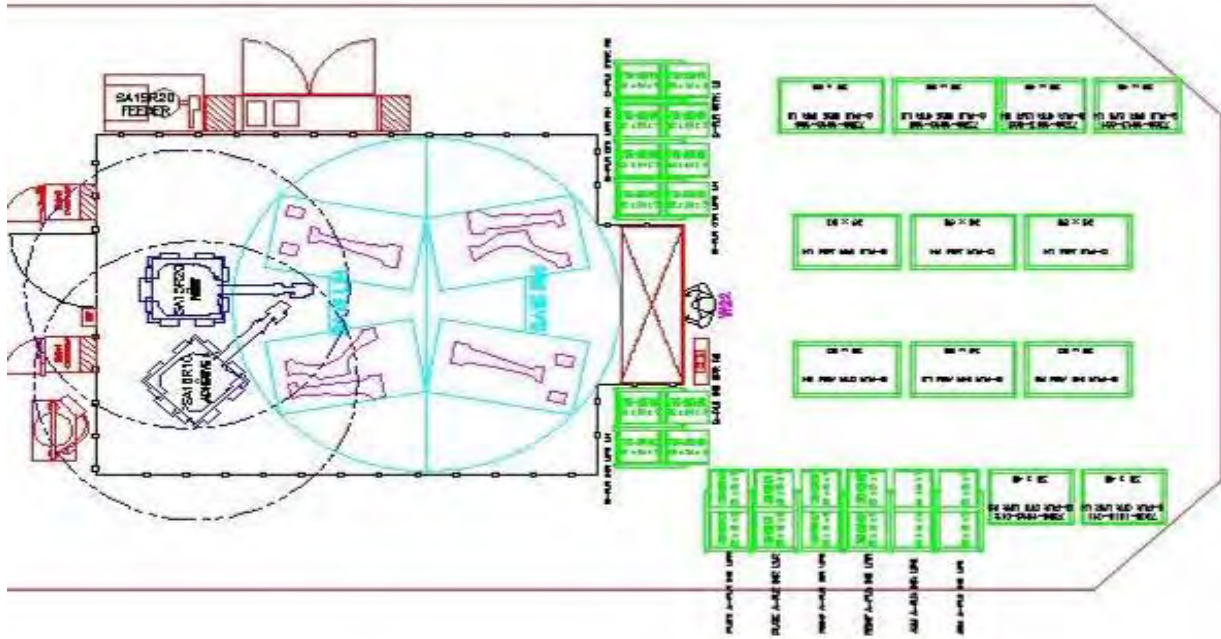

Figure 2.7.c: Station SA15 layout

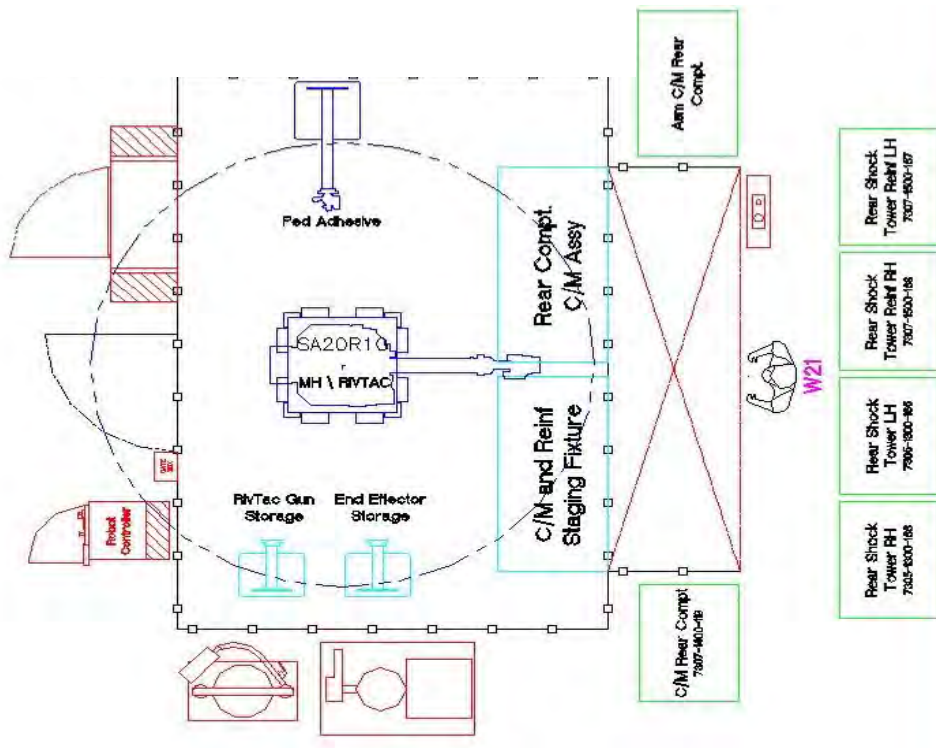

Figure 2.7.d: Station SA20 layout

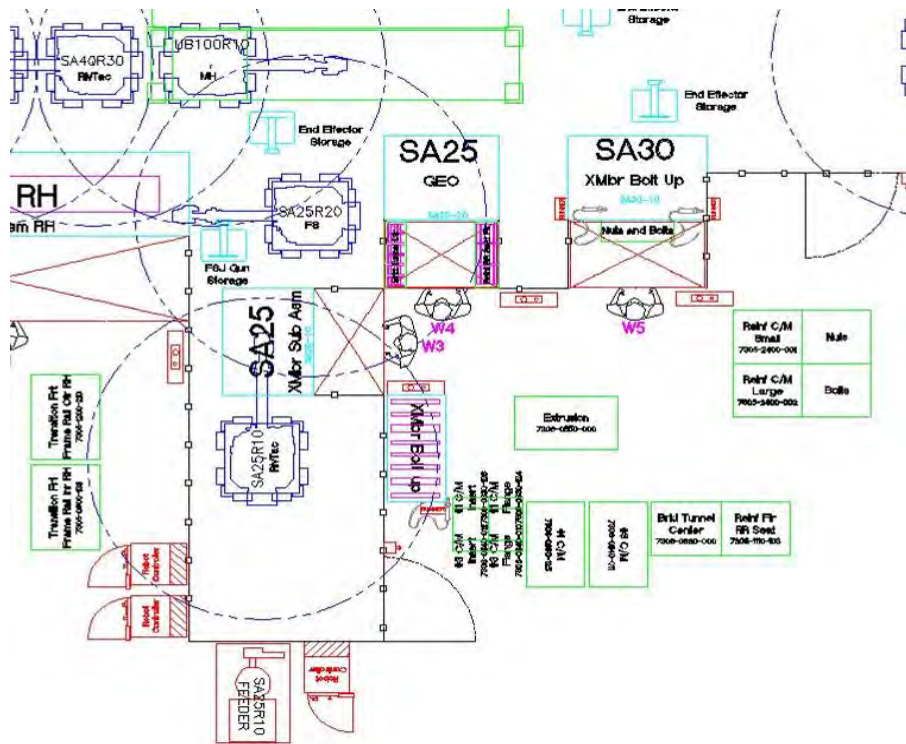

Figure 2.7.e: Stations SA25, SA30 layout

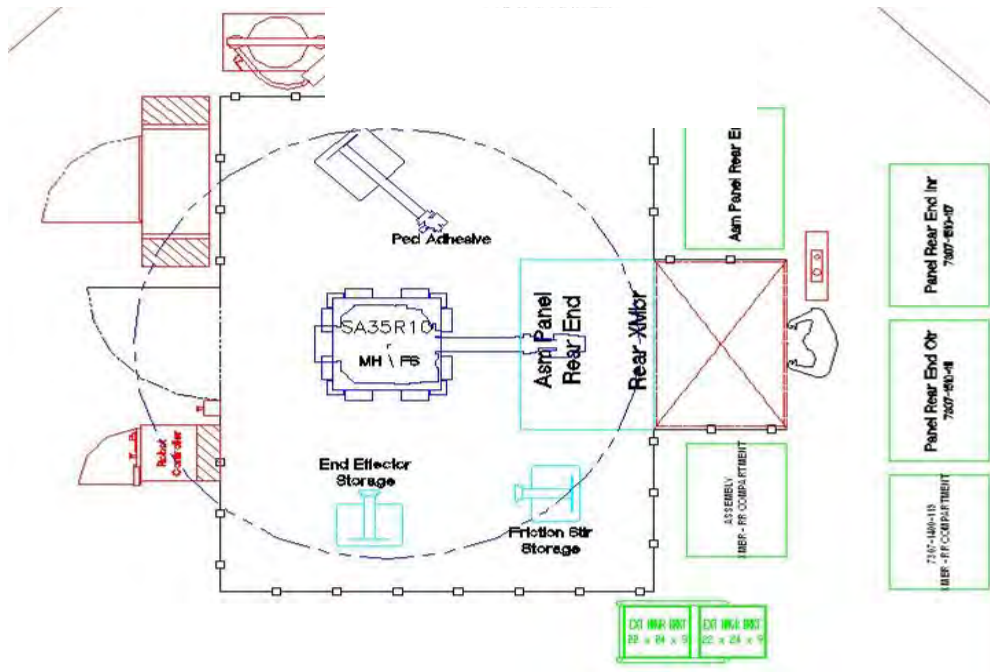

Figure 2.7.f: Station SA35 layout

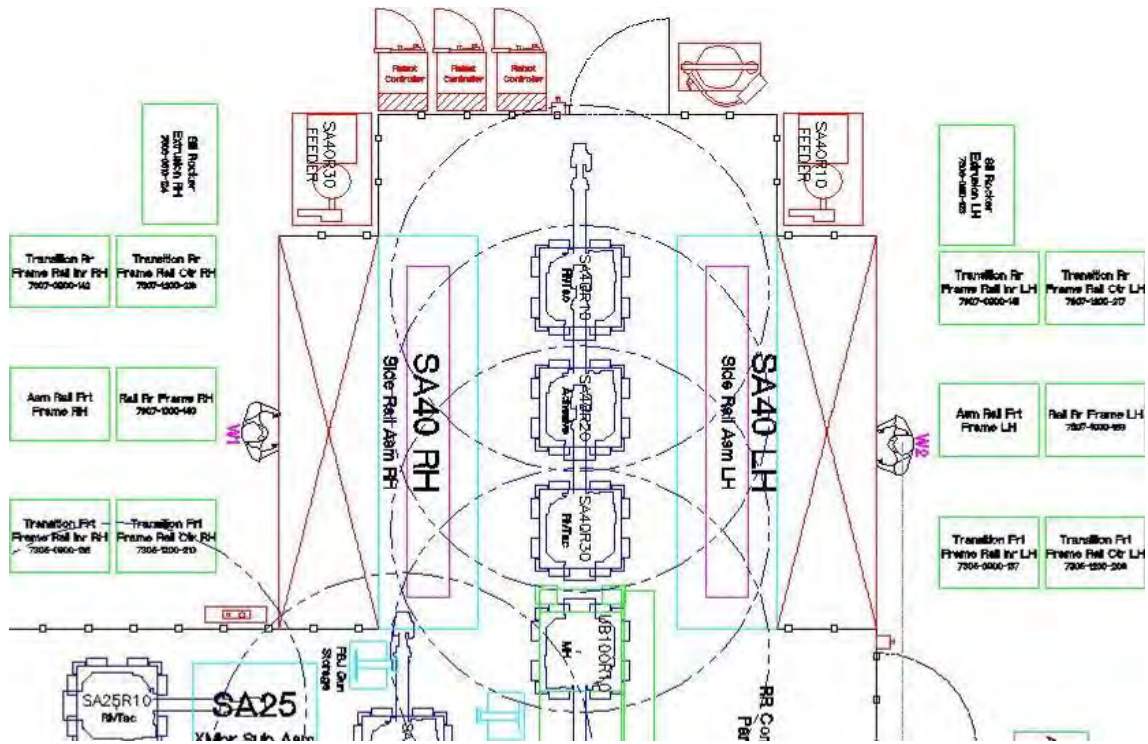

Figure 2.7.g: Station SA40 layout

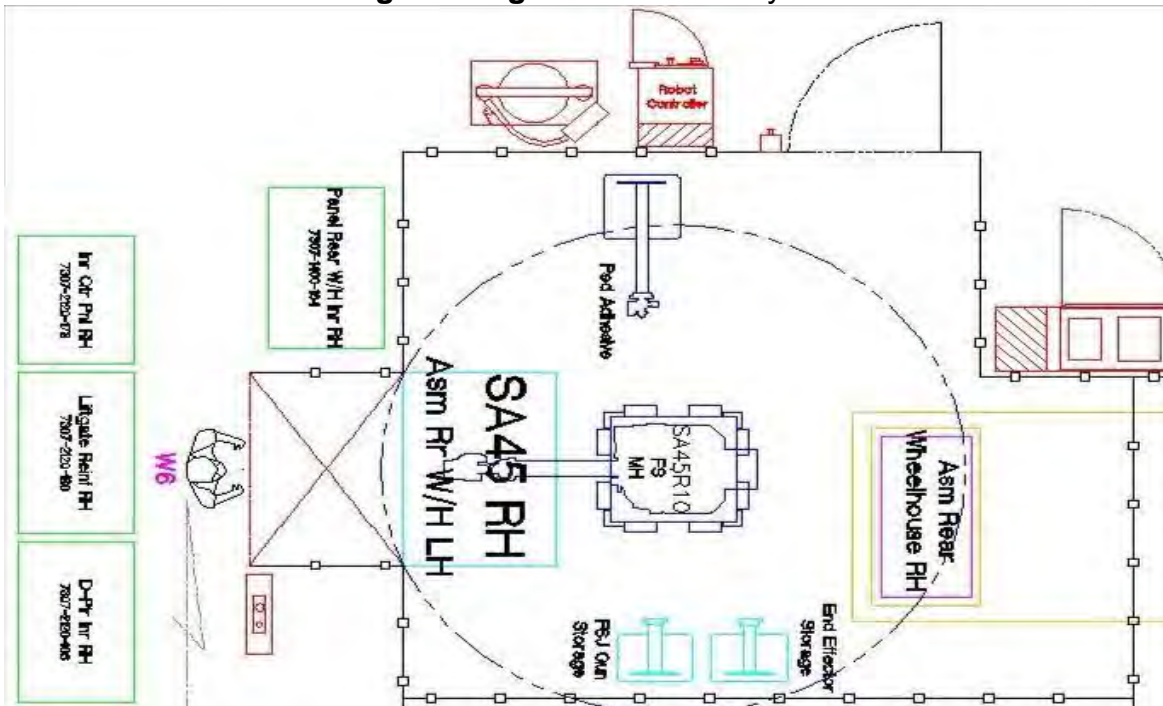

Figure 2.7.h: Station SA45, right-side assembly layout

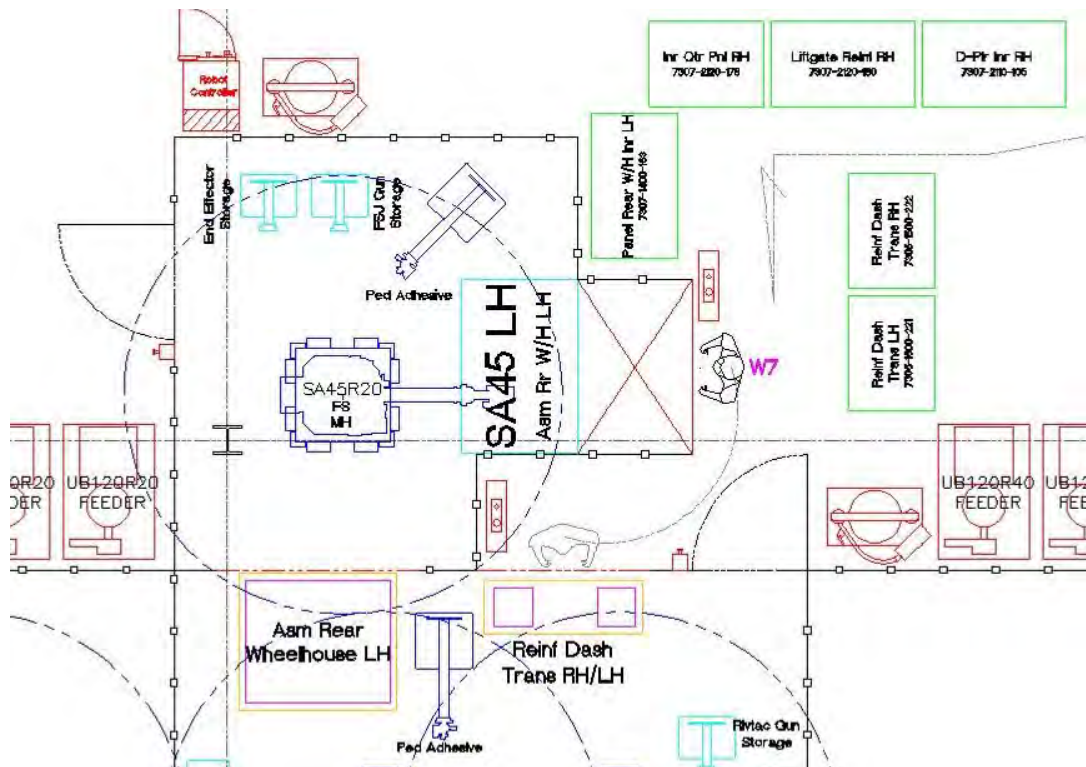

Figure 2.7.i: Station SA45, left-side assembly layout

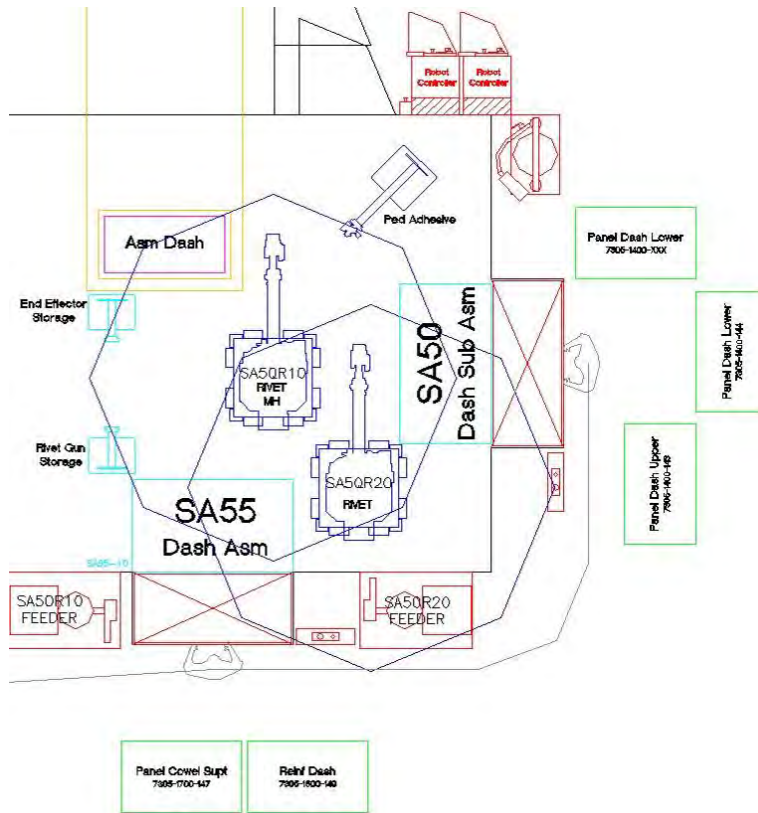

Figure 2.7.j: Stations SA50, SA55 layout

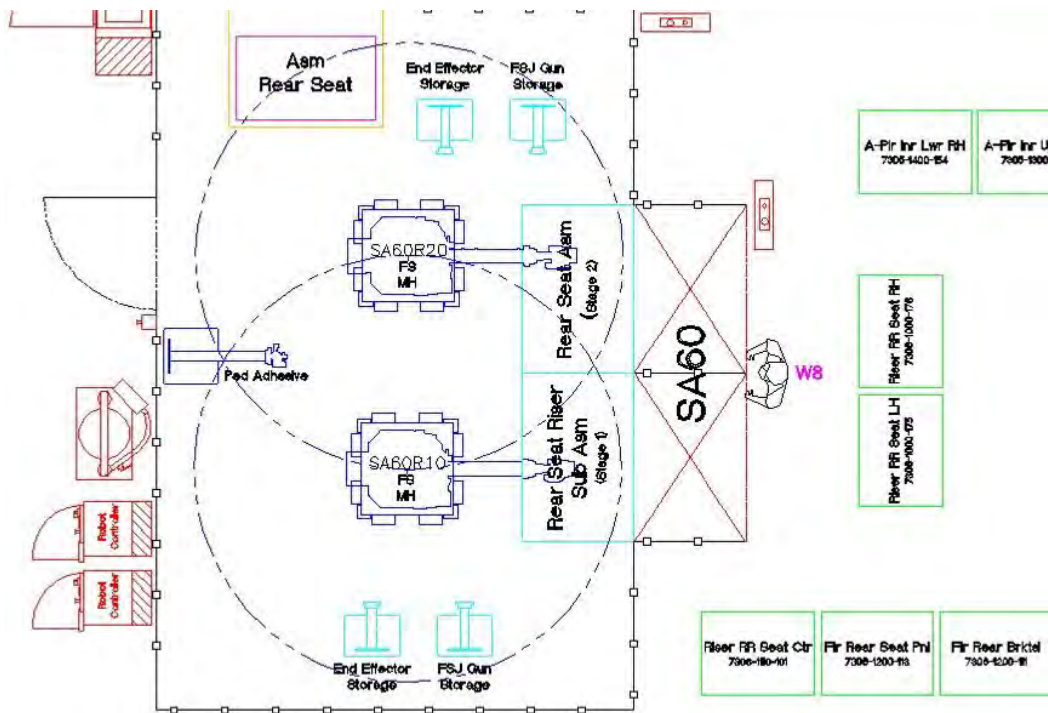

Figure 2.7.k: Station SA60 layout

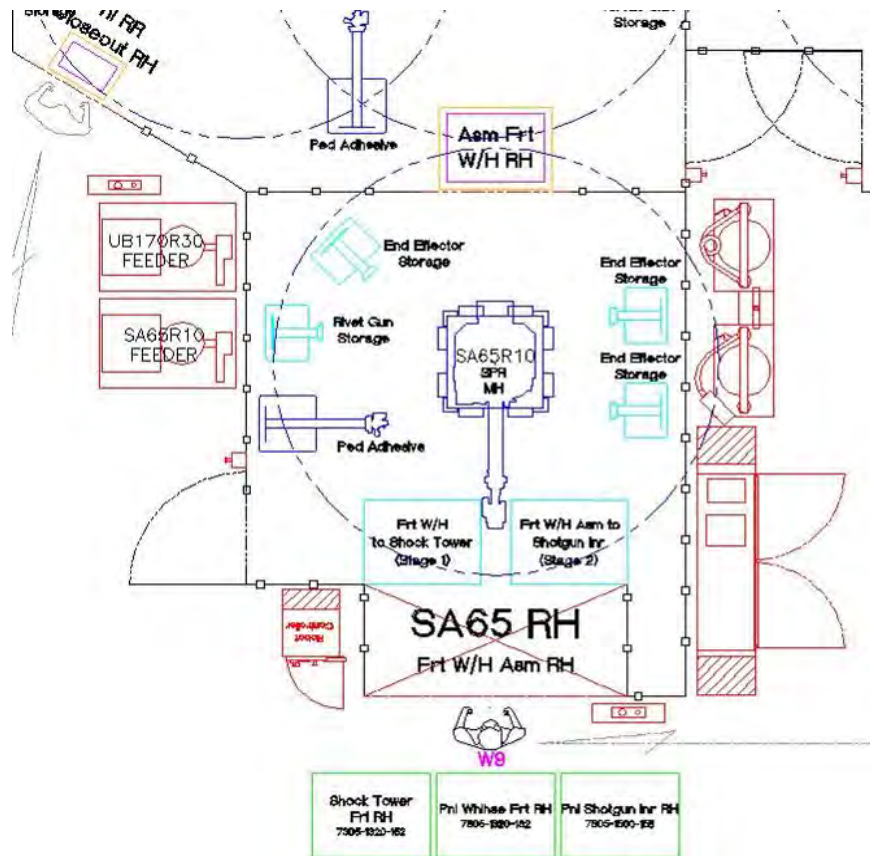

Figure 2.7.I: Station SA65, right-side assembly layout

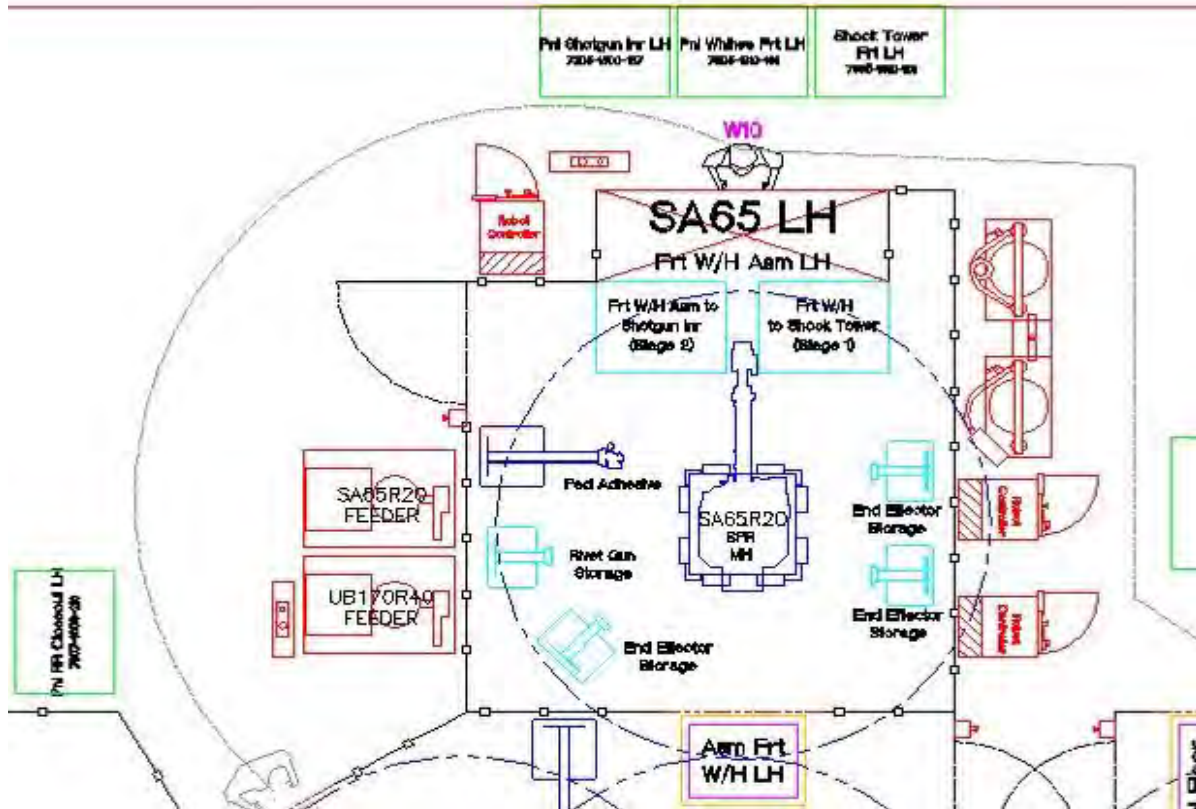

Figure 2.7.m: Station SA65, left-side assembly layout

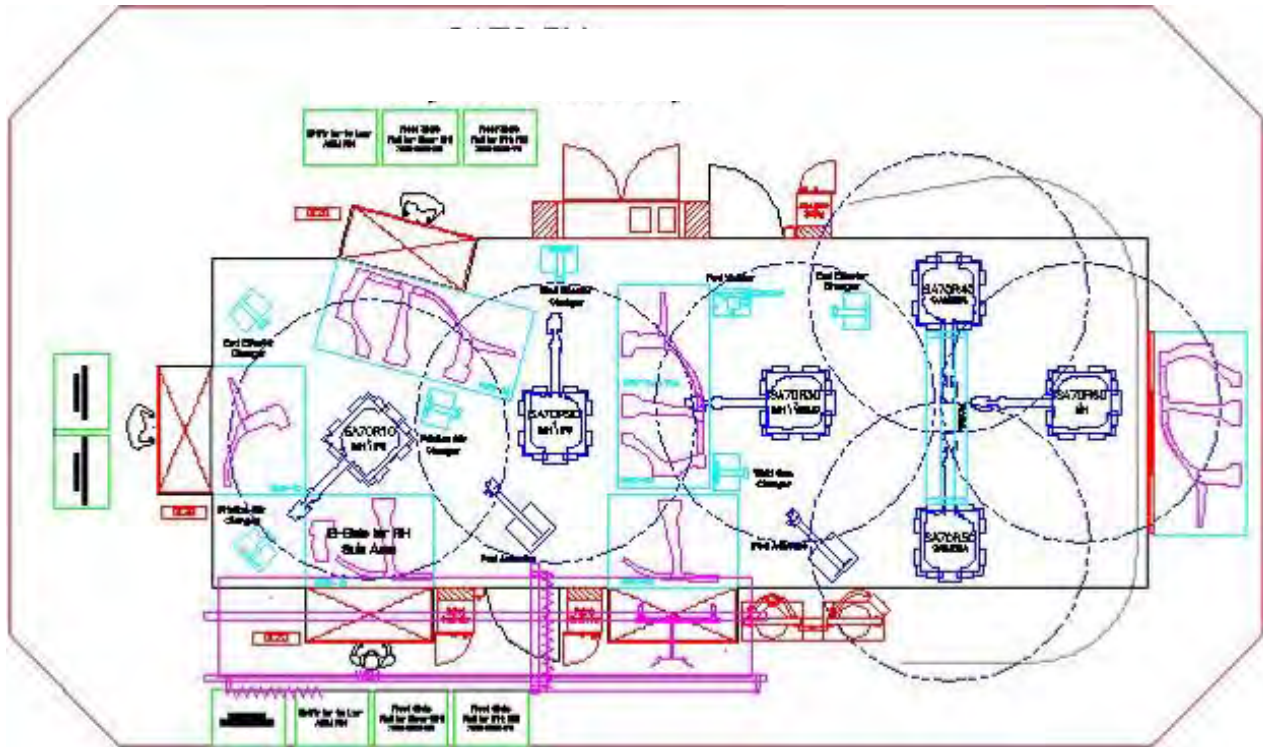

Figure 2.7.n: Station SA70, right-side assembly layout

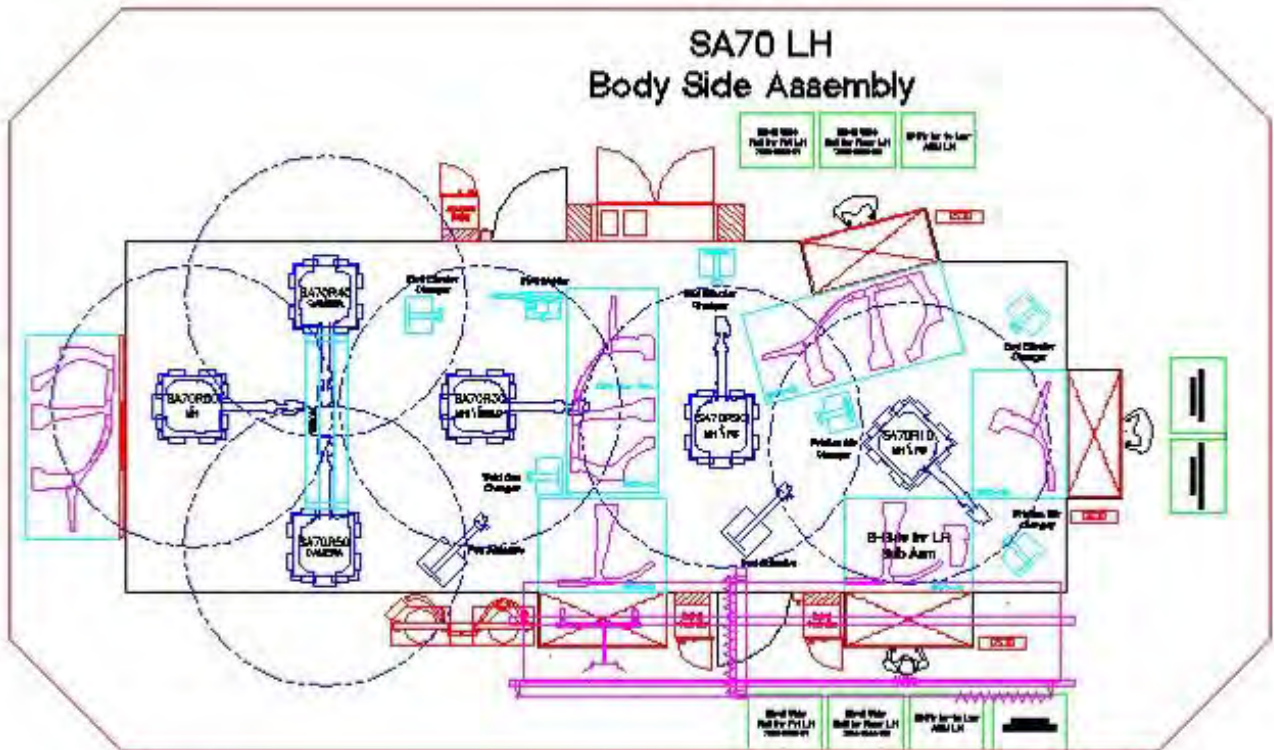

Figure 2.7.o: Station SA70, left-side assembly layout

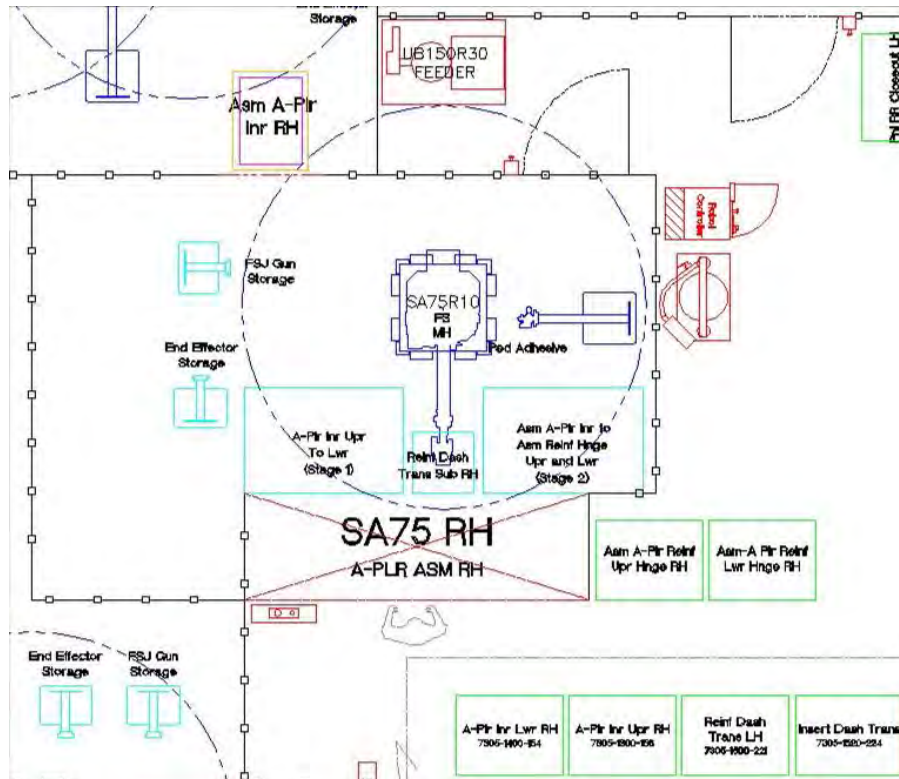

Figure 2.7.p: Station SA75, right-side assembly layout

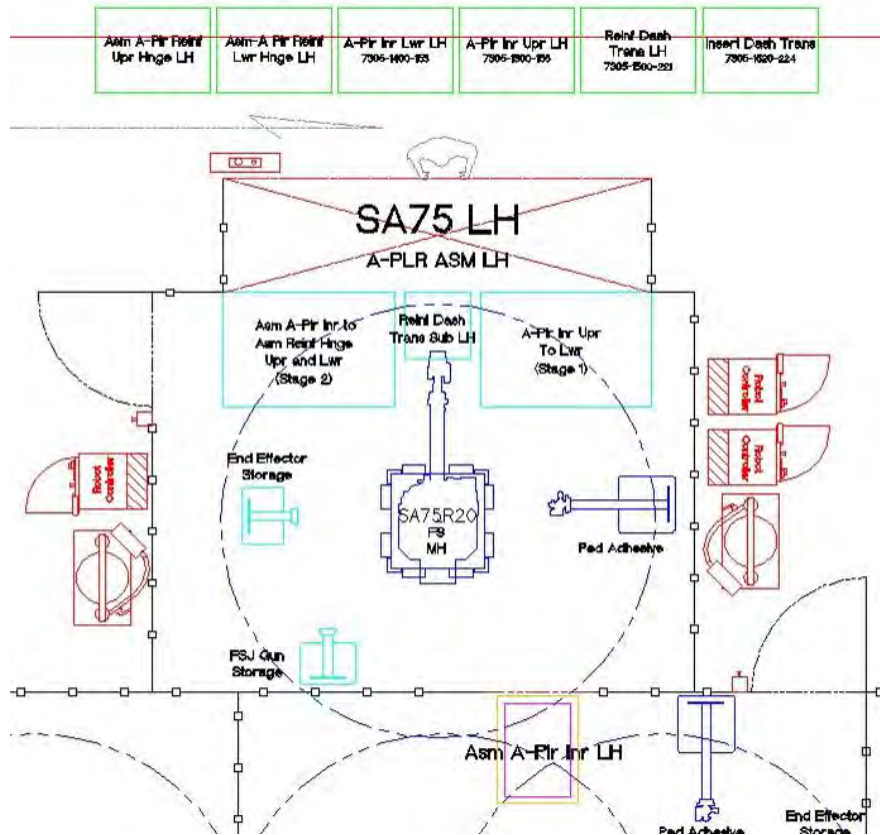

Figure 2.7.q: Station SA75, left-side assembly

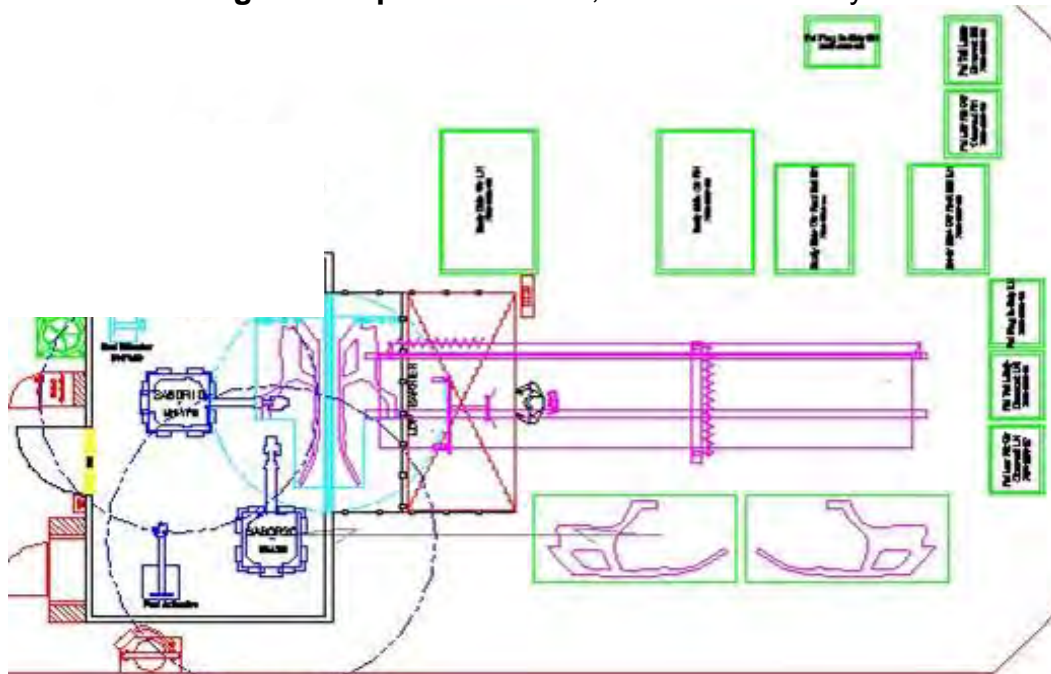

Figure 2.7.r: Station SA80 assembly layout

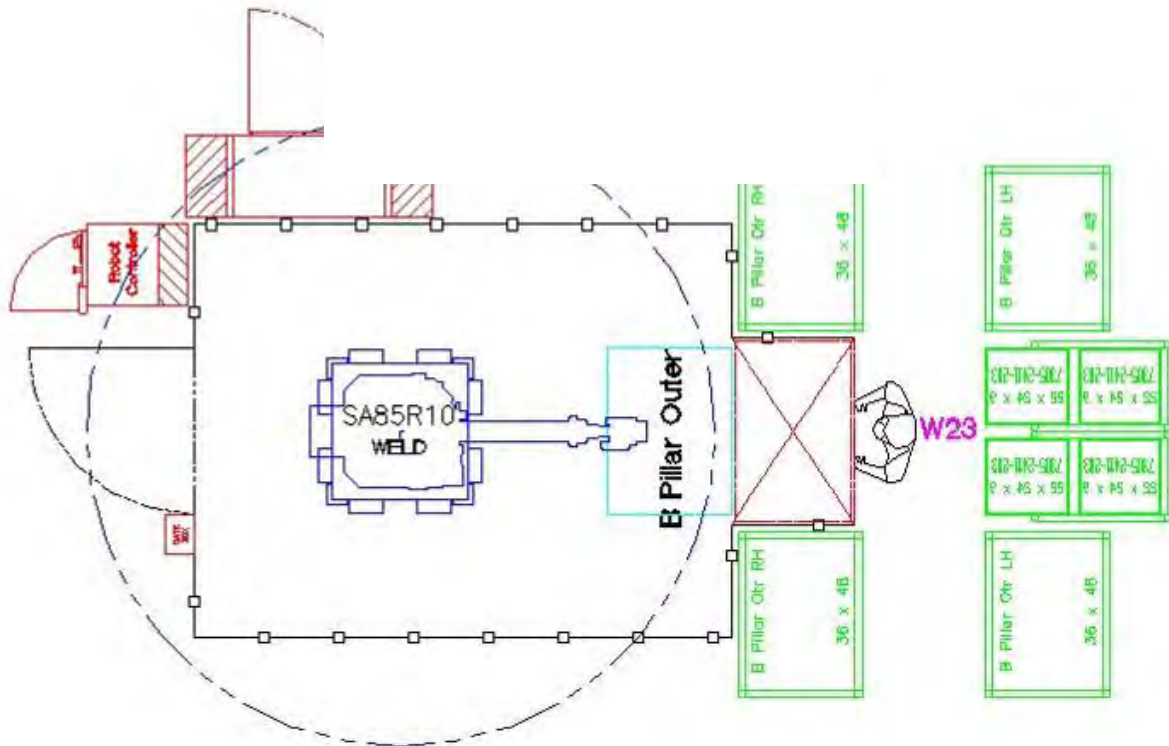

Figure 2.7.s: Station SA85 assembly layout

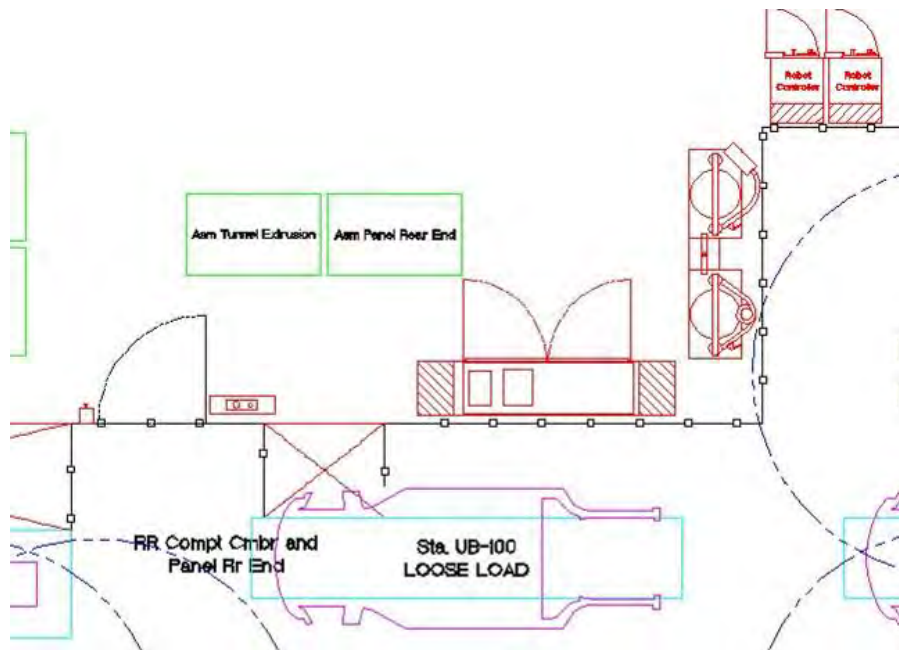

Figure 2.7.t: Station UB100 assembly layout

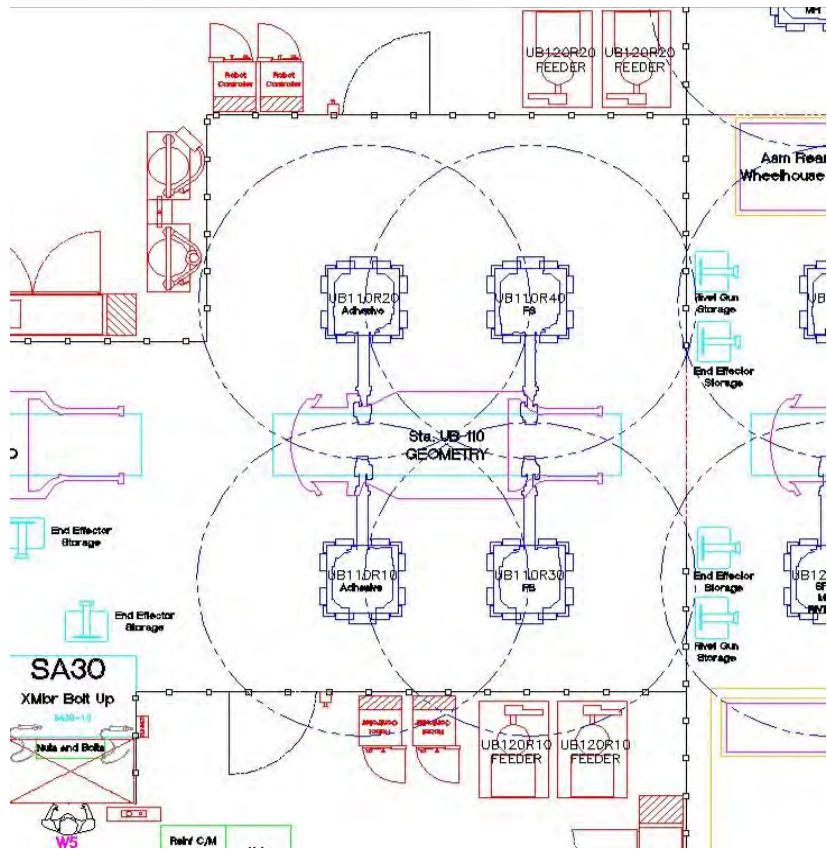

Figure 2.7.u: Station UB110 assembly layout

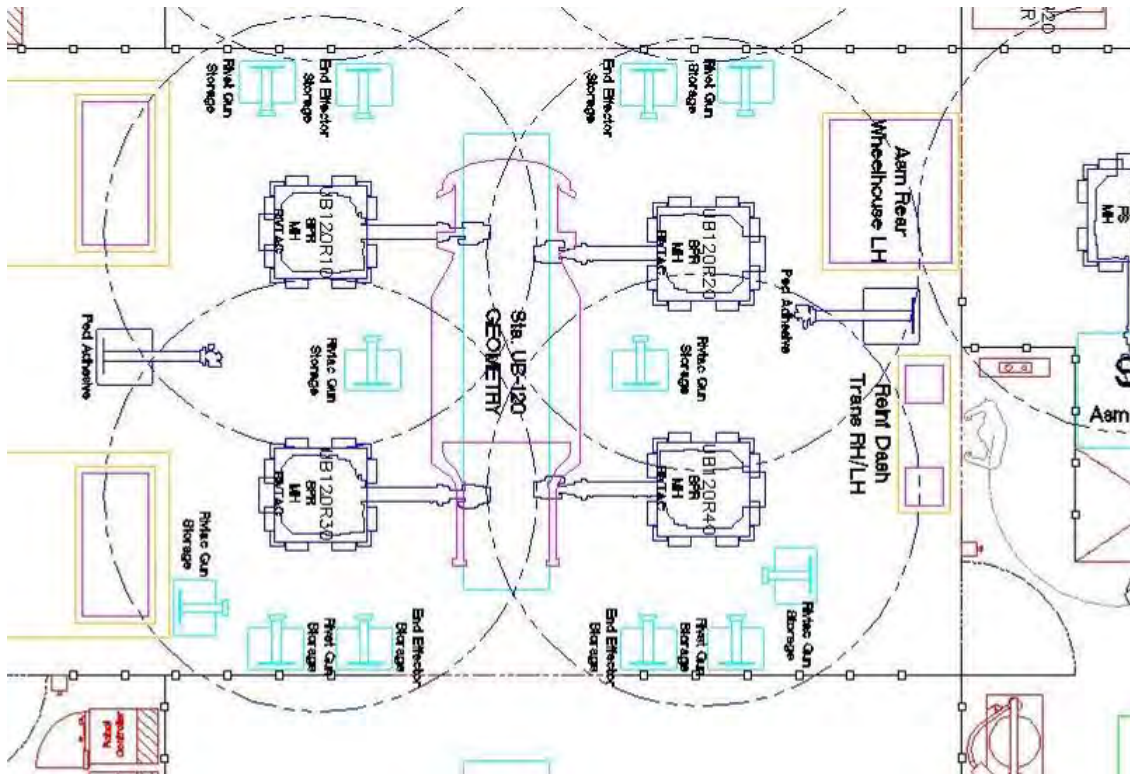

Figure 2.7.v: Station UB120 assembly layout

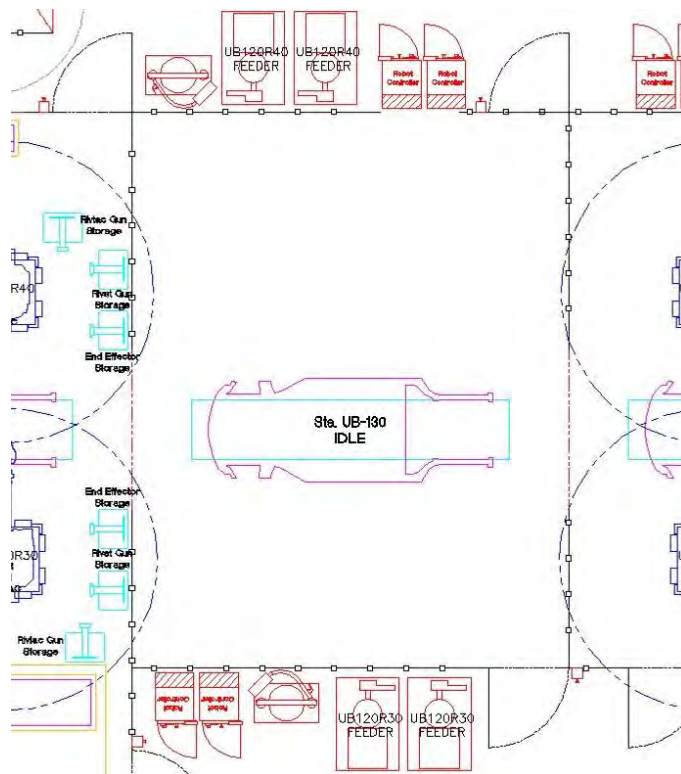

Figure 2.7.w: Station UB130 assembly layout

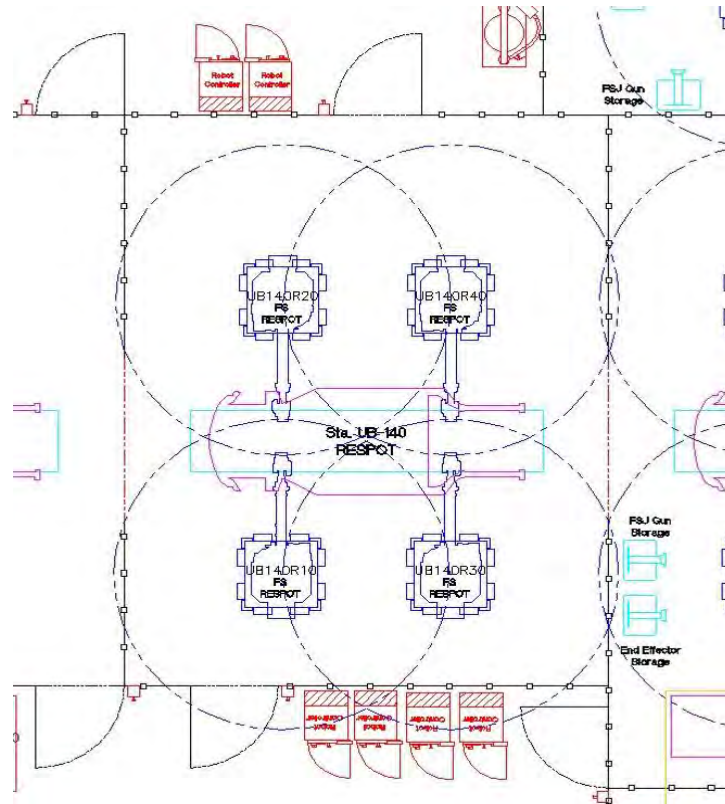

Figure 2.7.x: Station UB140 assembly layout

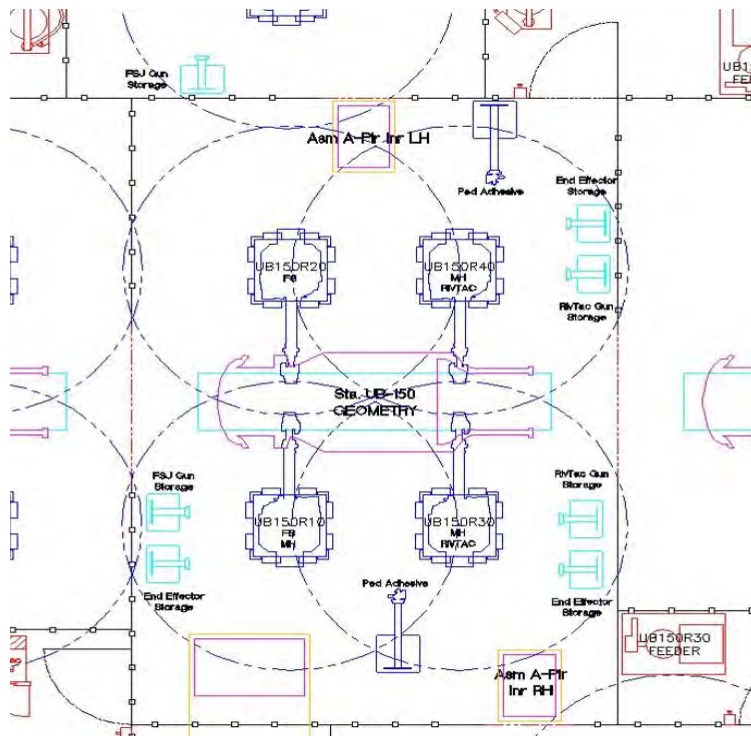

Figure 2.7.y: Station UB150 assembly layout

Figure 2.7.z: Station UB160 assembly layout

Figure 2.7.aa: Station UB170 assembly layout

Figure 2.7.ab: Station UB180 assembly layout

Figure 2.7.ac: Station UB190 assembly layout

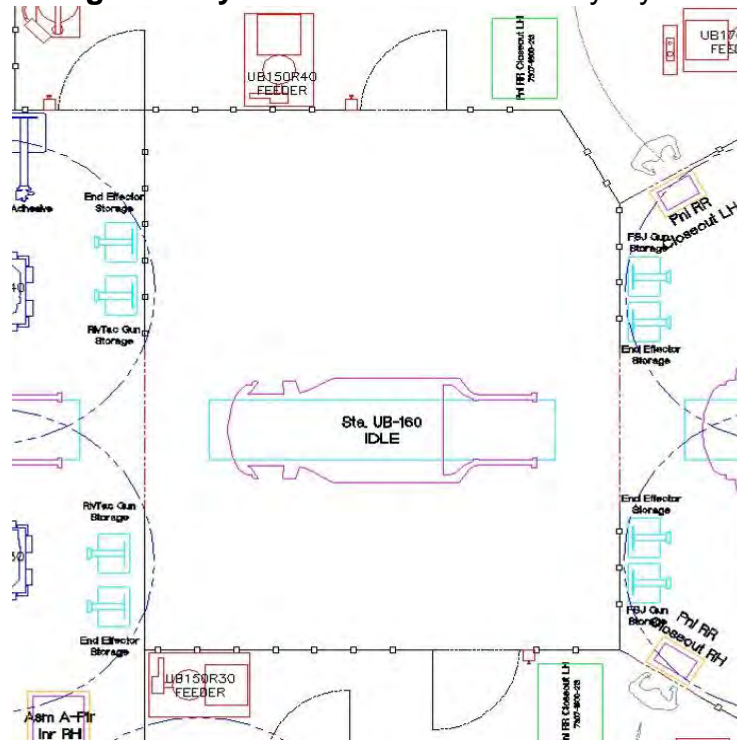
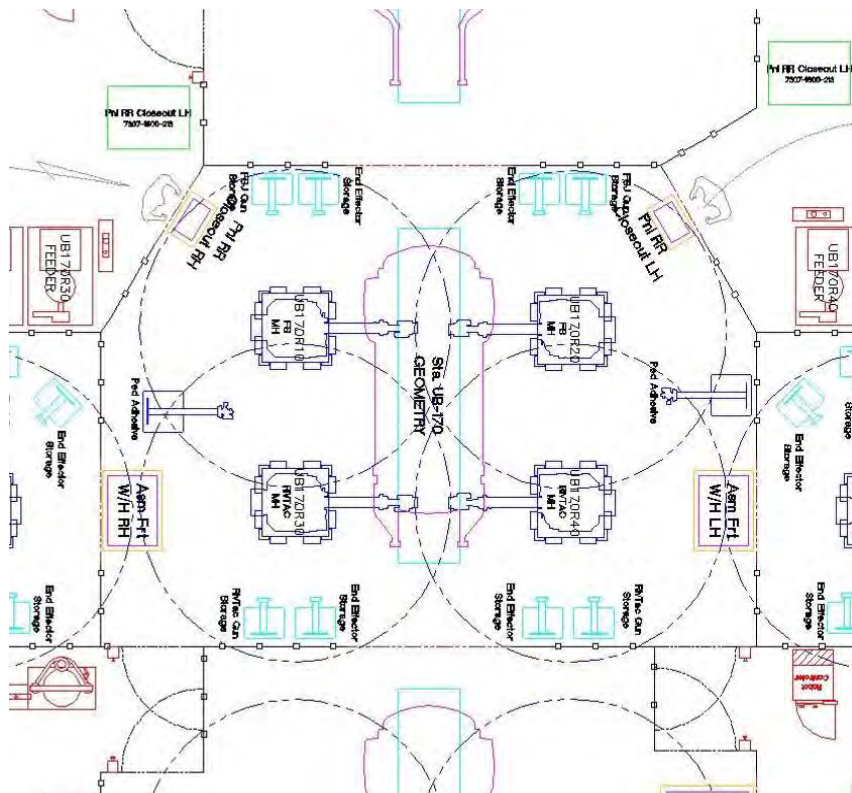
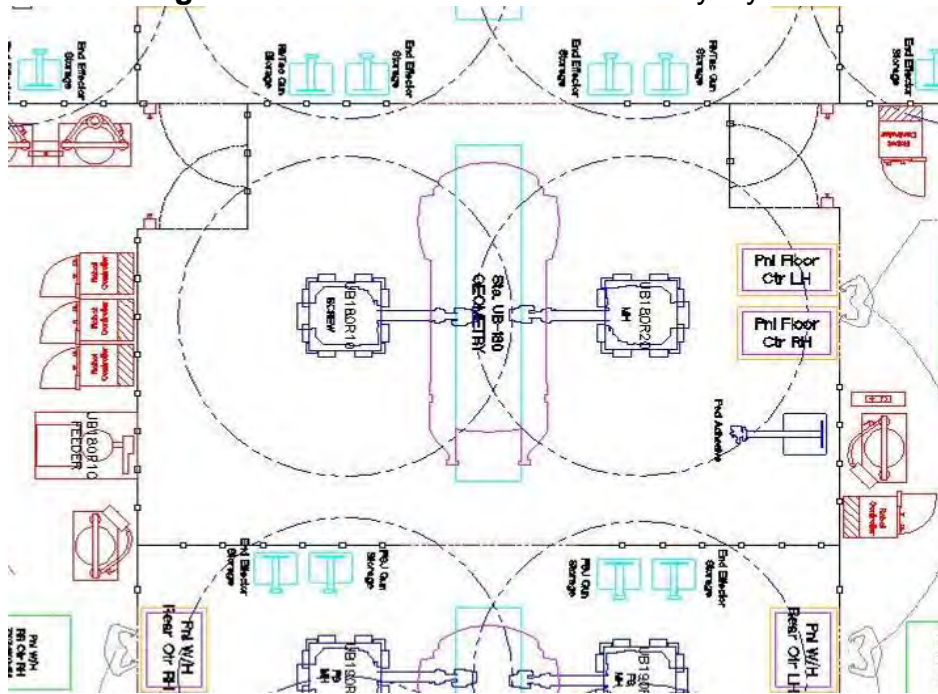
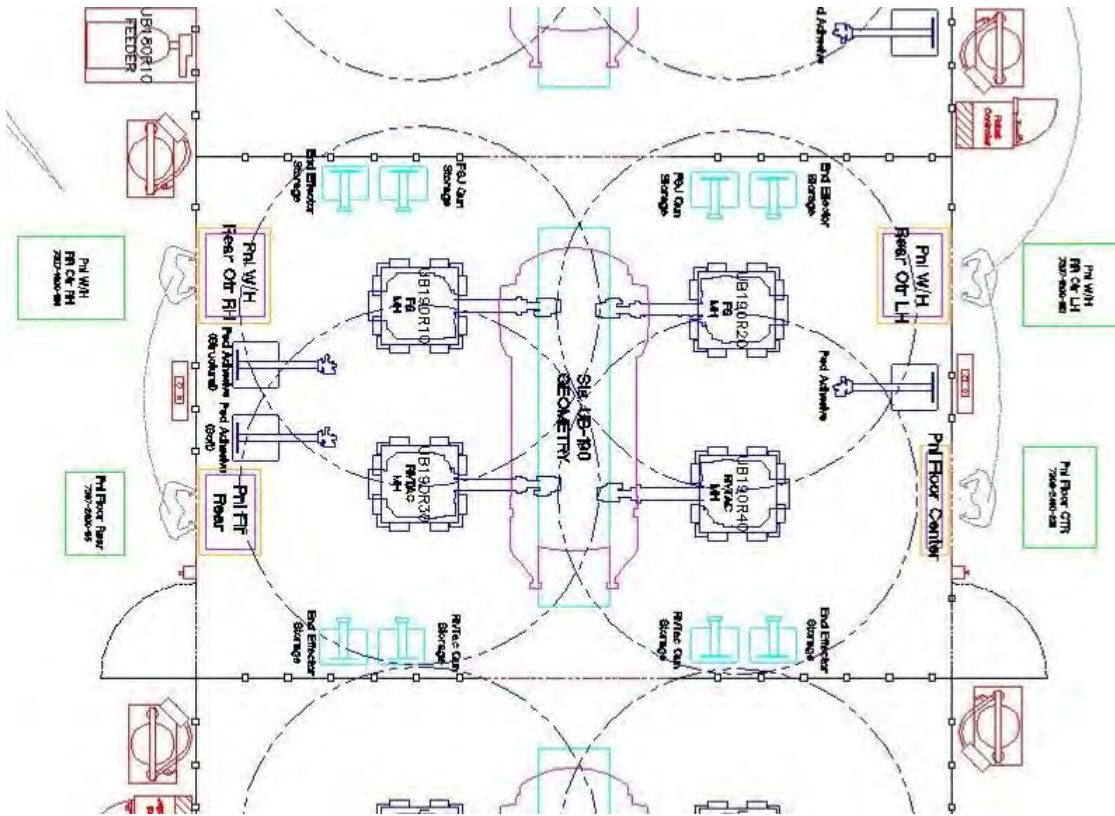
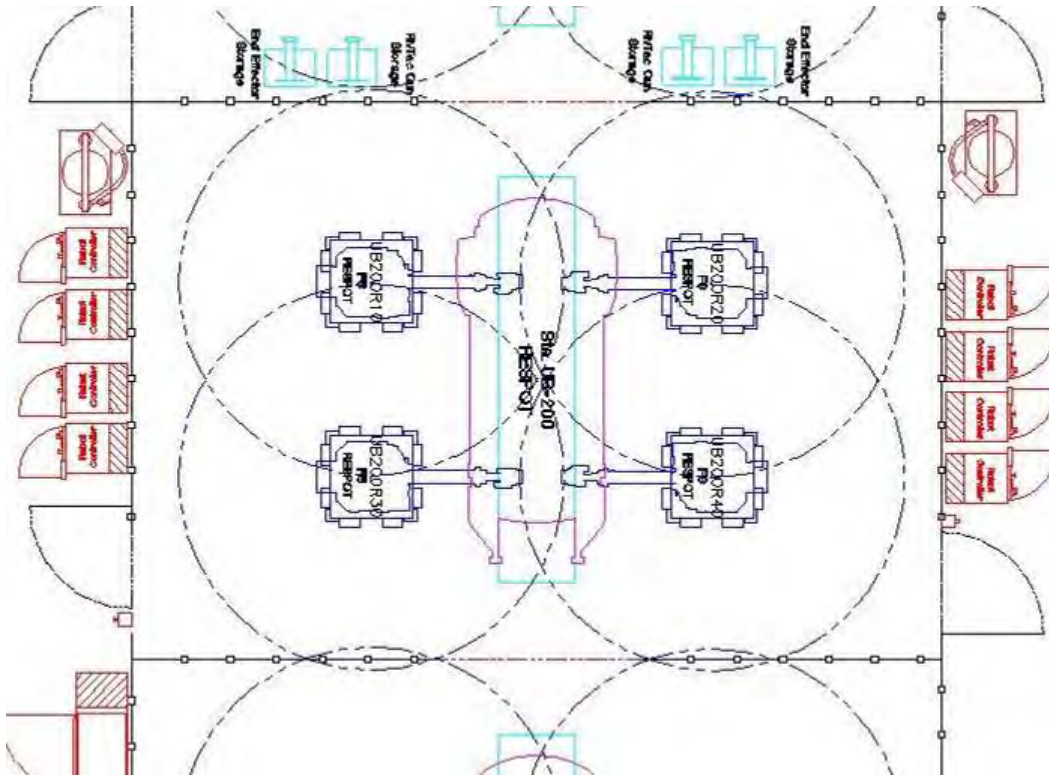

Figure 2.7.ad: Station UB200 assembly layout

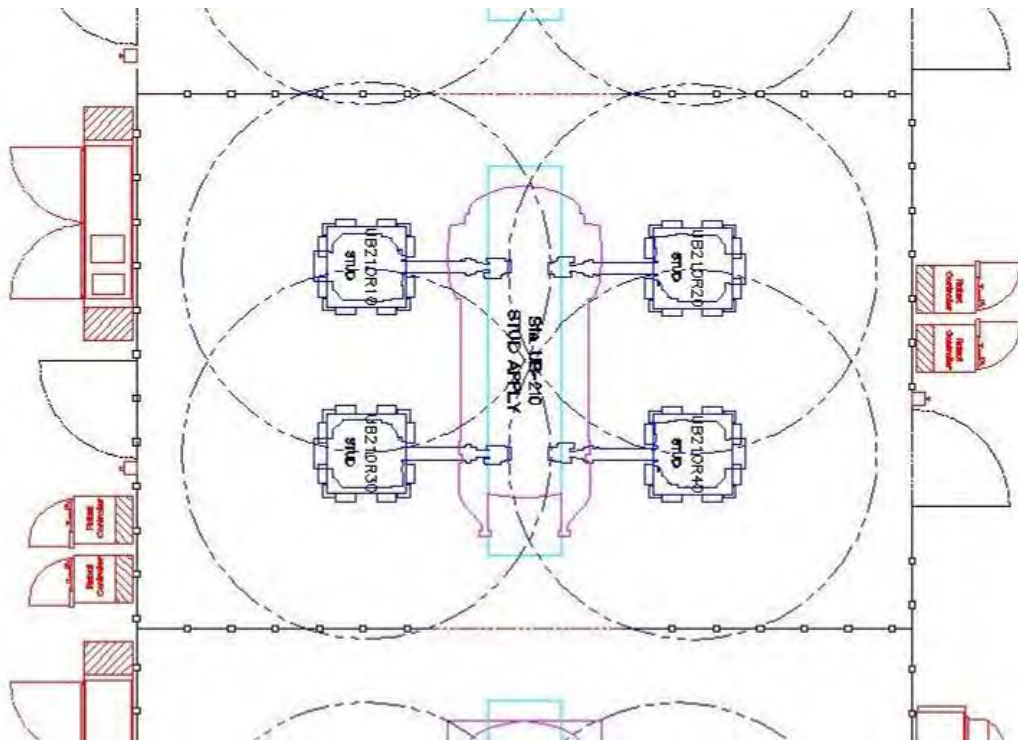

Figure 2.7.ae: Station UB210 assembly layout

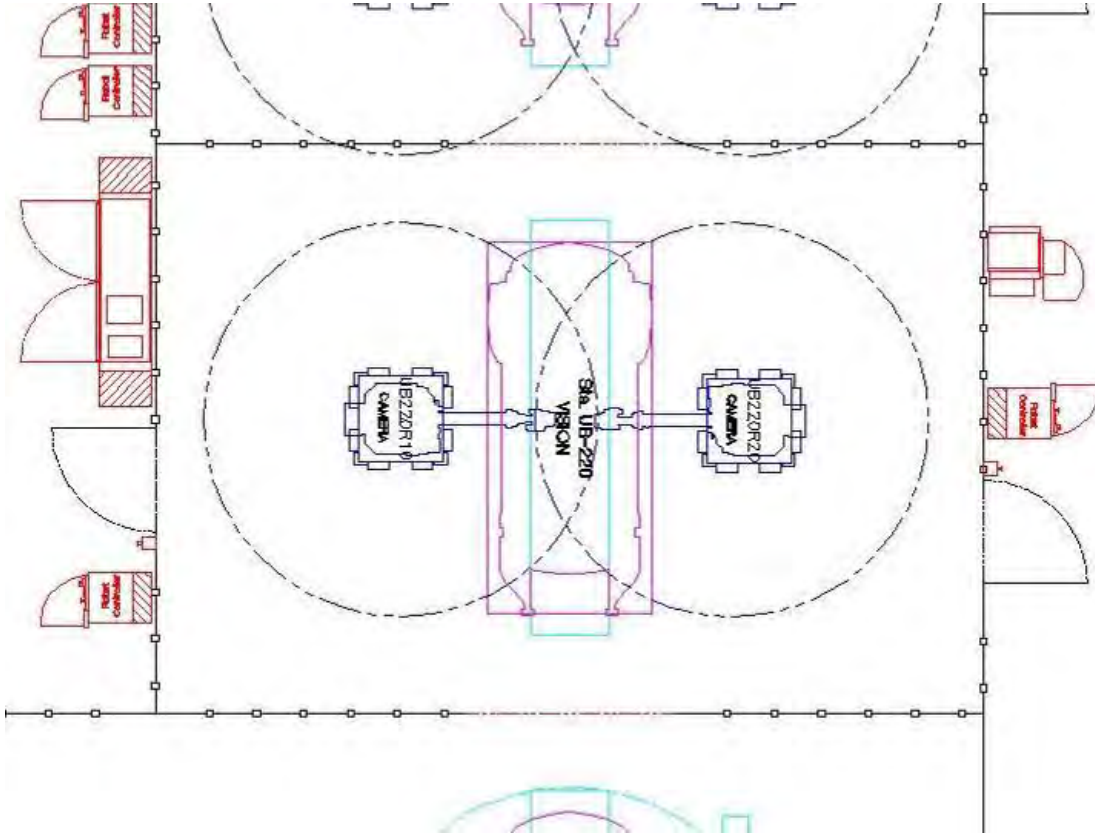

Figure 2.7.af: Station UB220 assembly layout

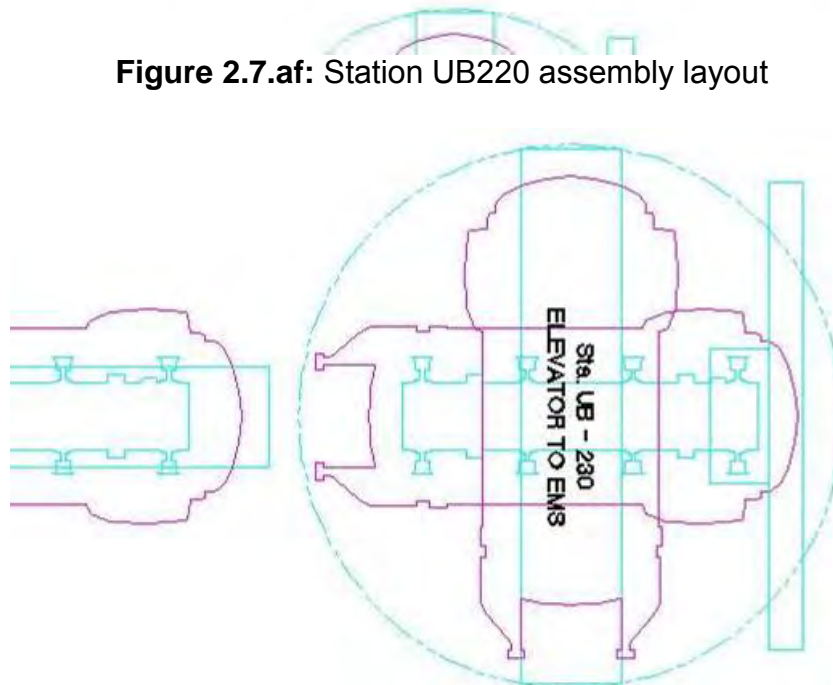

Figure 2.7.ag: Station UB230 assembly layout

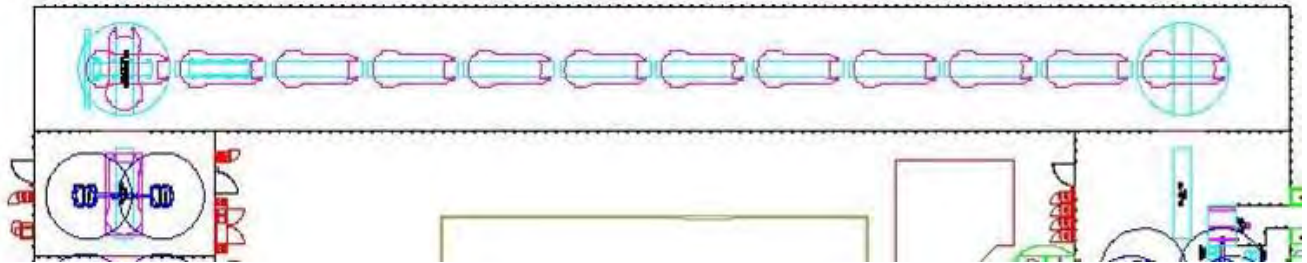

Figure 2.7.ah: Cross transport

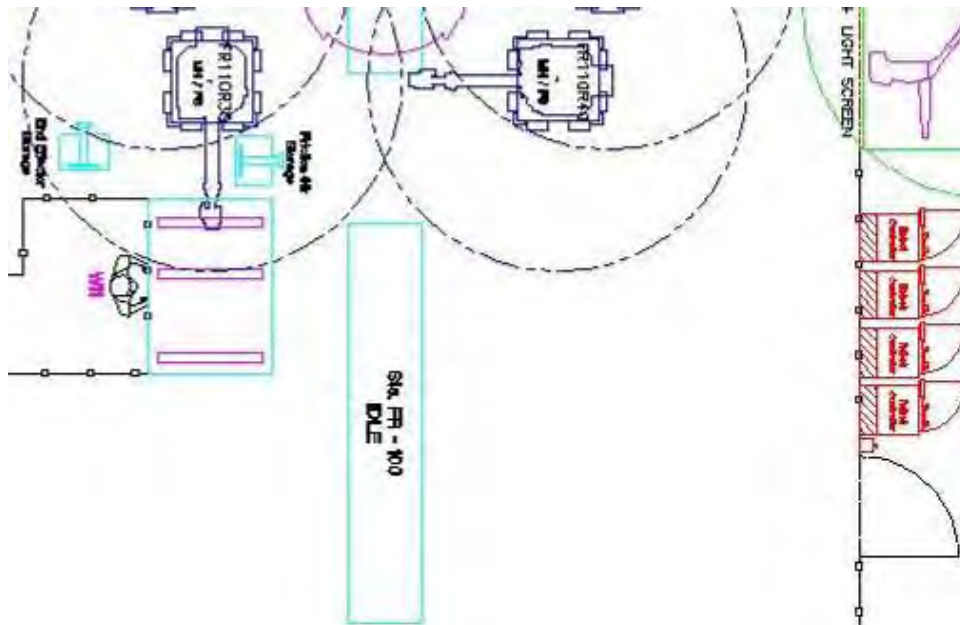

Figure 2.7.ai: Station FR100 assembly layout

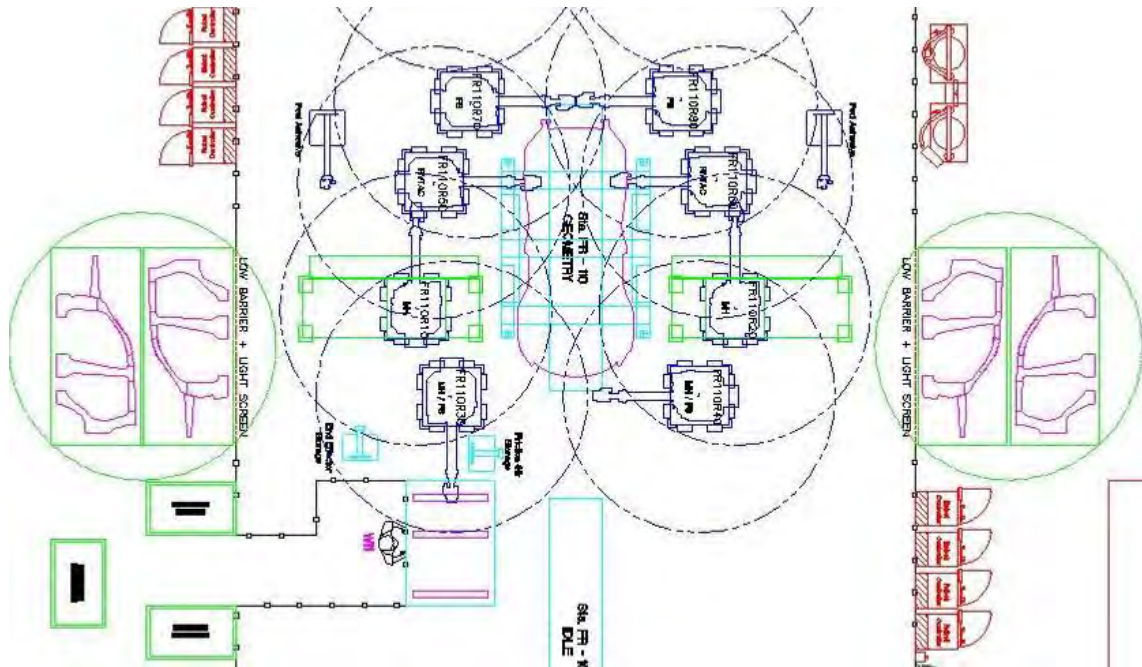

Figure 2.7.aj: Station FR110 assembly layout

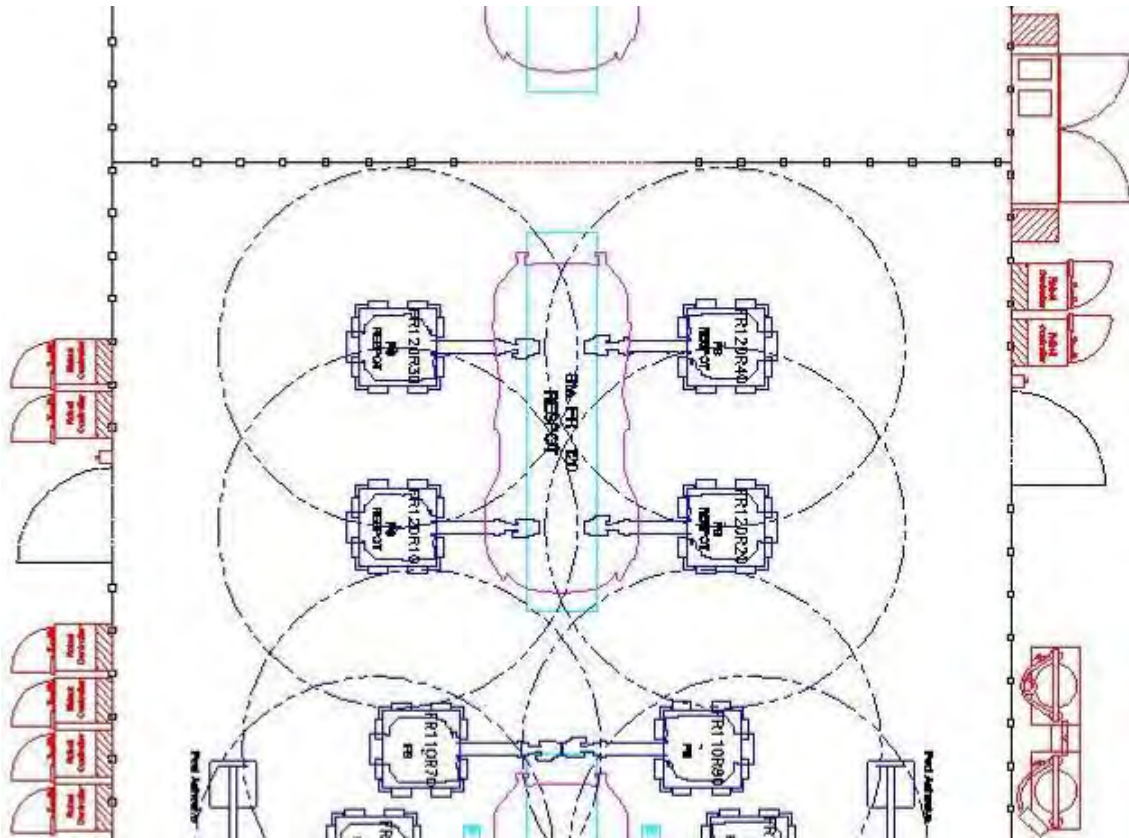

Figure 2.7.ak: Station FR120 assembly layout

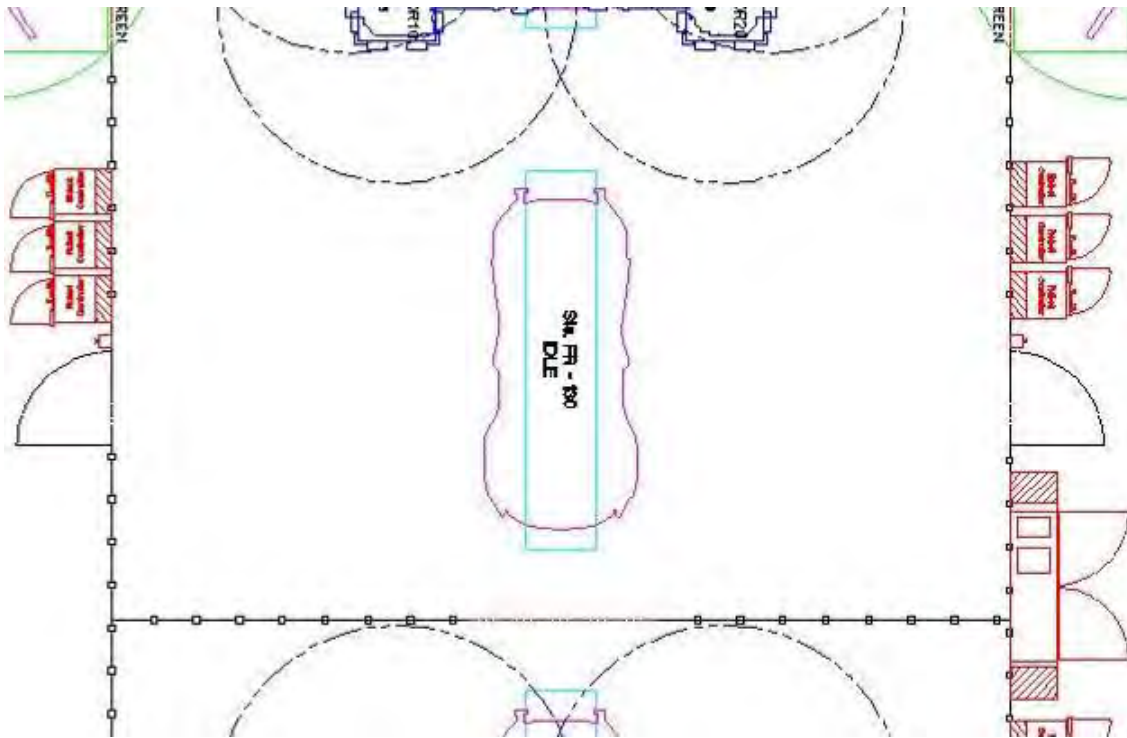

Figure 2.7.aI: Station FR130 assembly layout

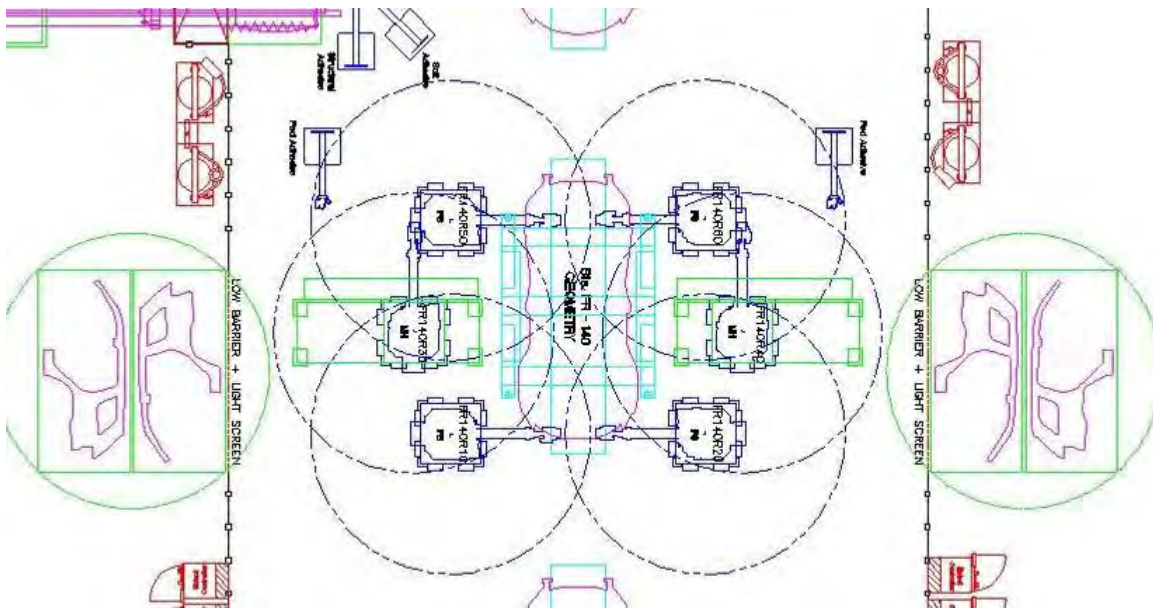

Figure 2.7.am: Station FR140 assembly layout

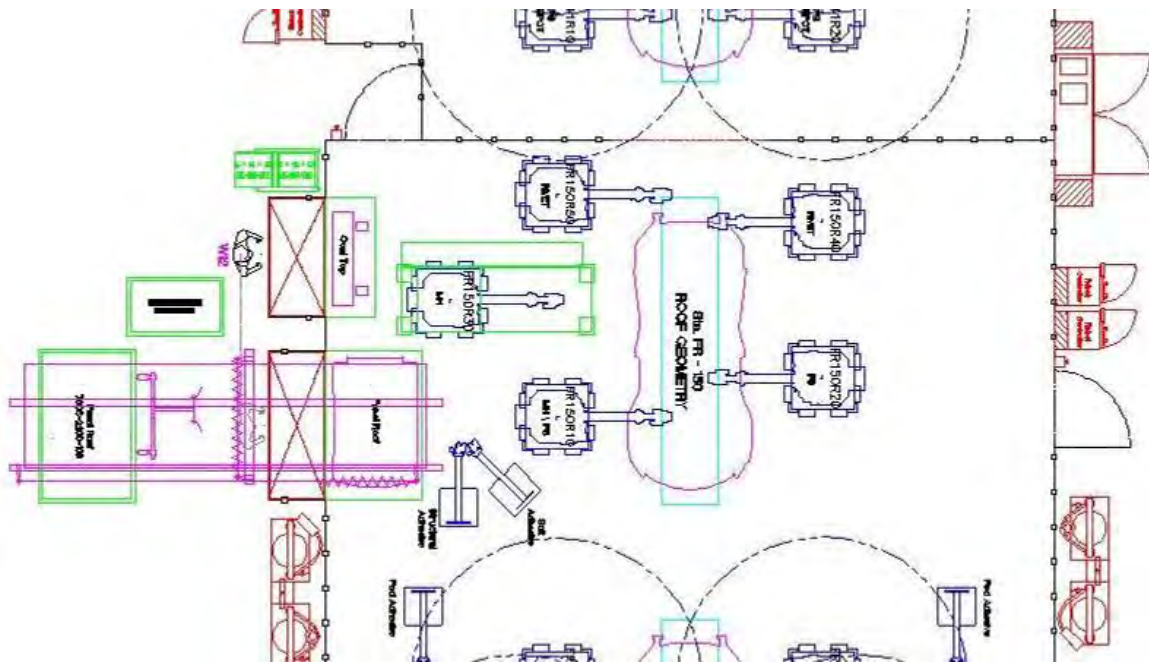

Figure 2.7.an: Station FR150 assembly layout

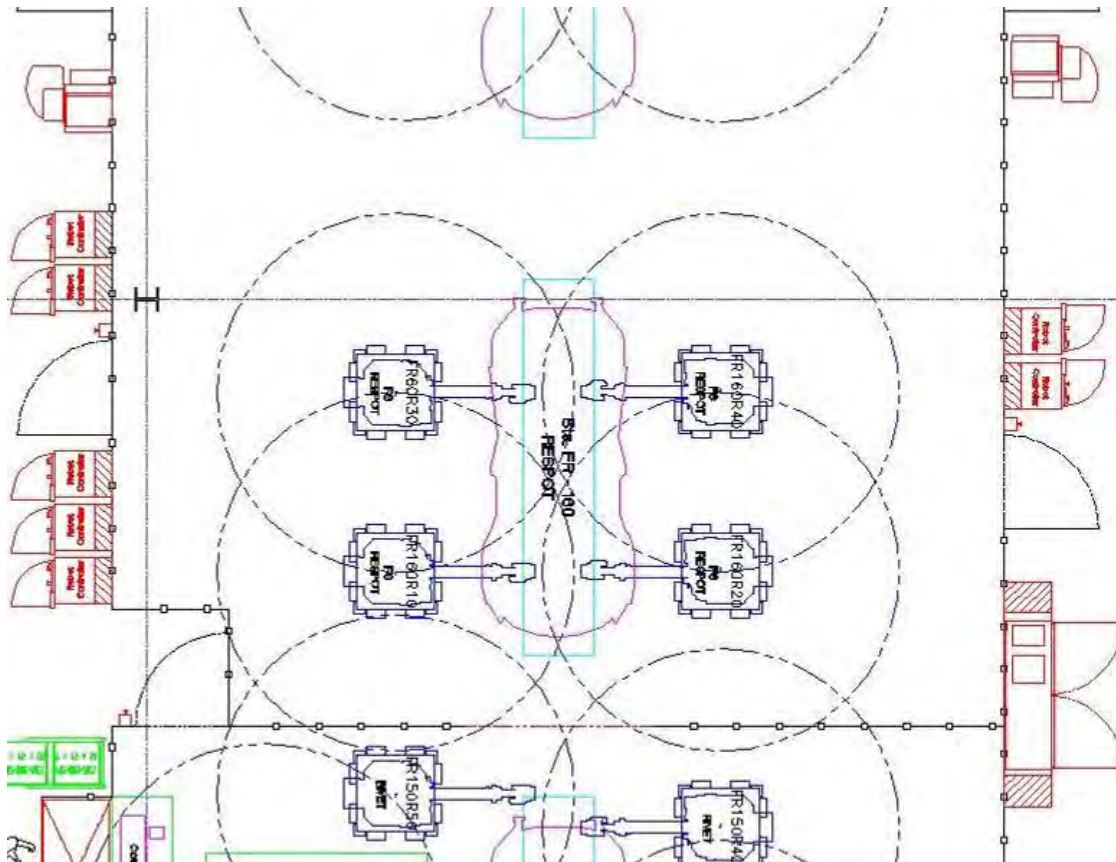

Figure 2.7.ao: Station FR160 assembly layout

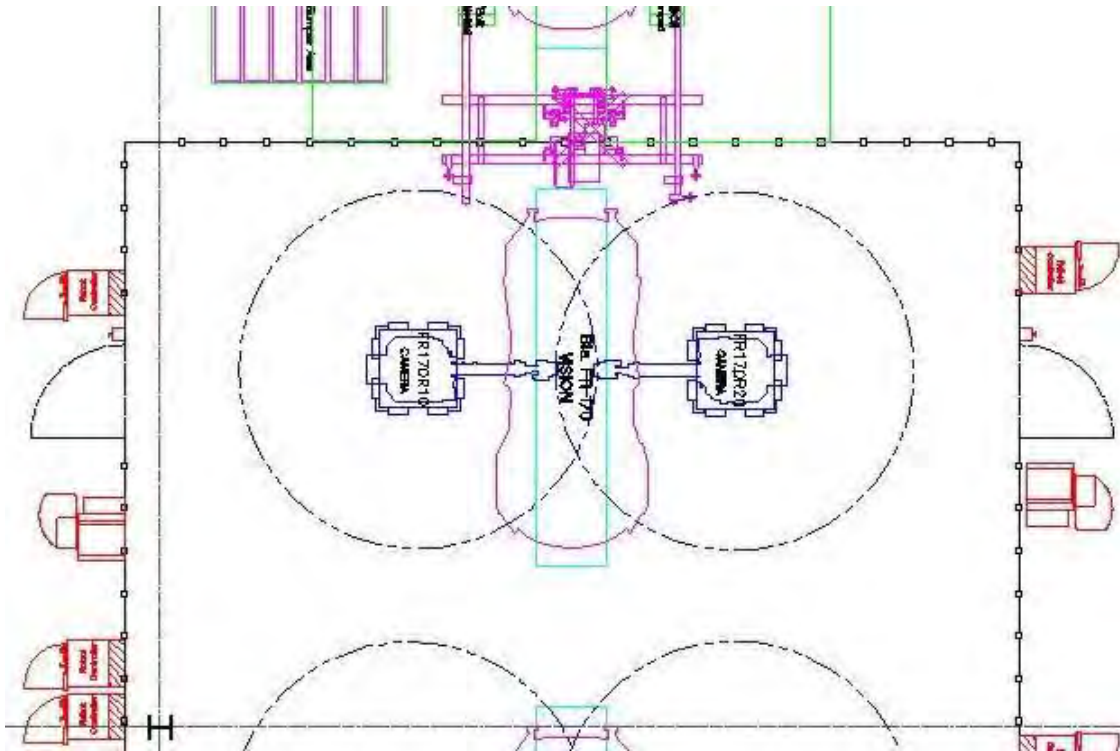

Figure 2.7.ap: Station FR170 assembly layout

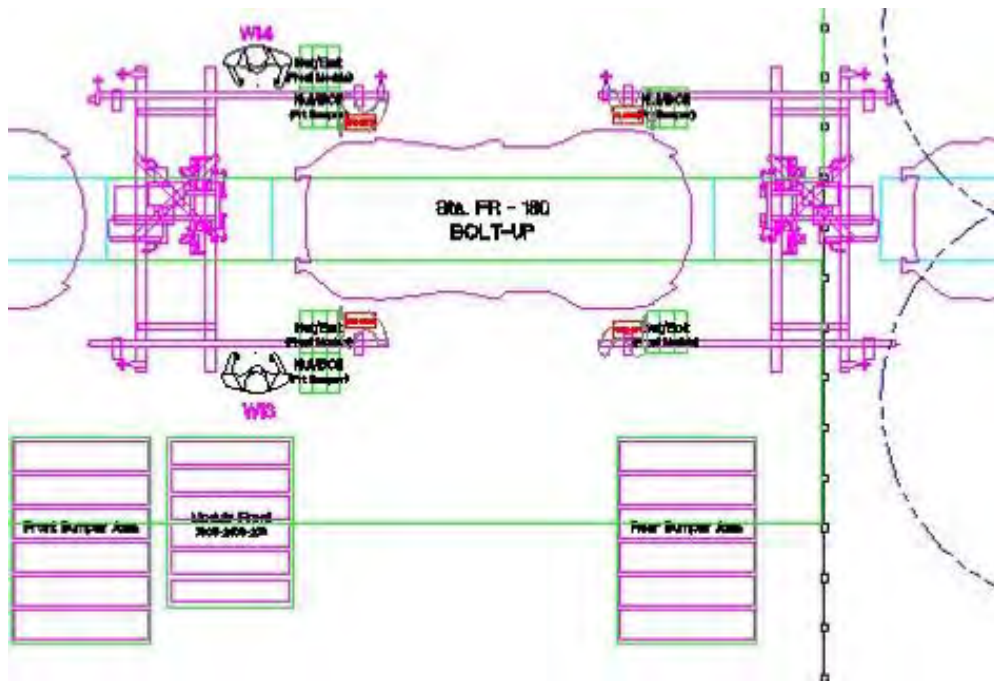

Figure 2.7.aq: Station FR180 assembly layout

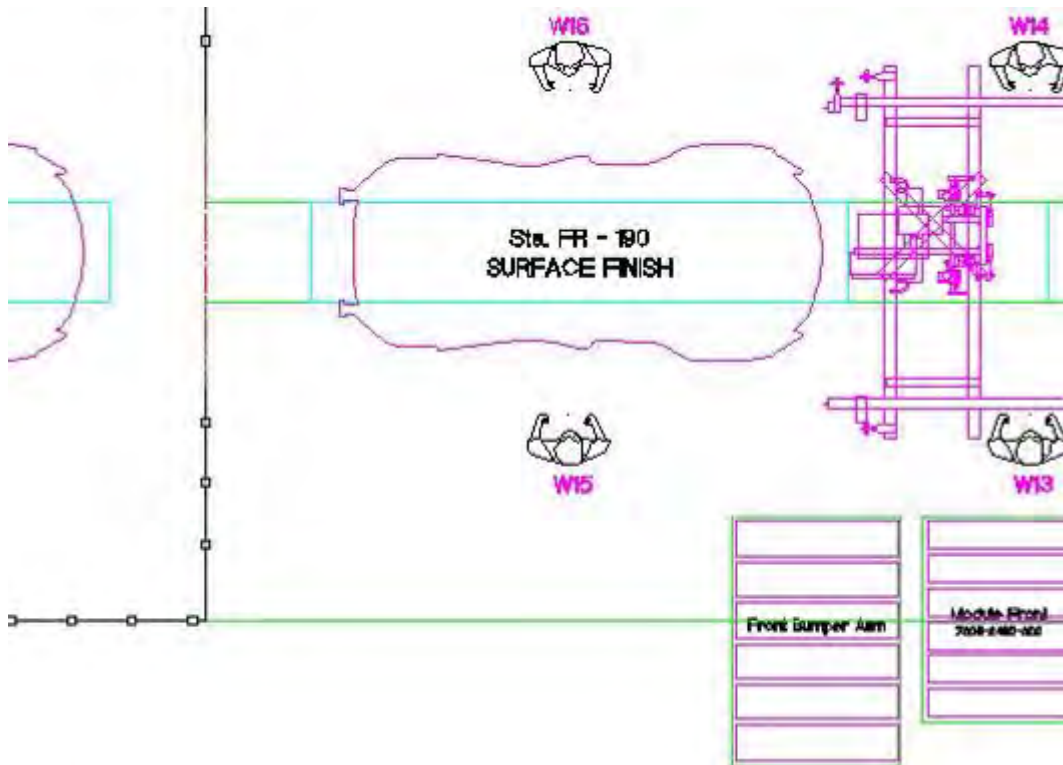

Figure 2.7.ar: Station FR190 assembly layout

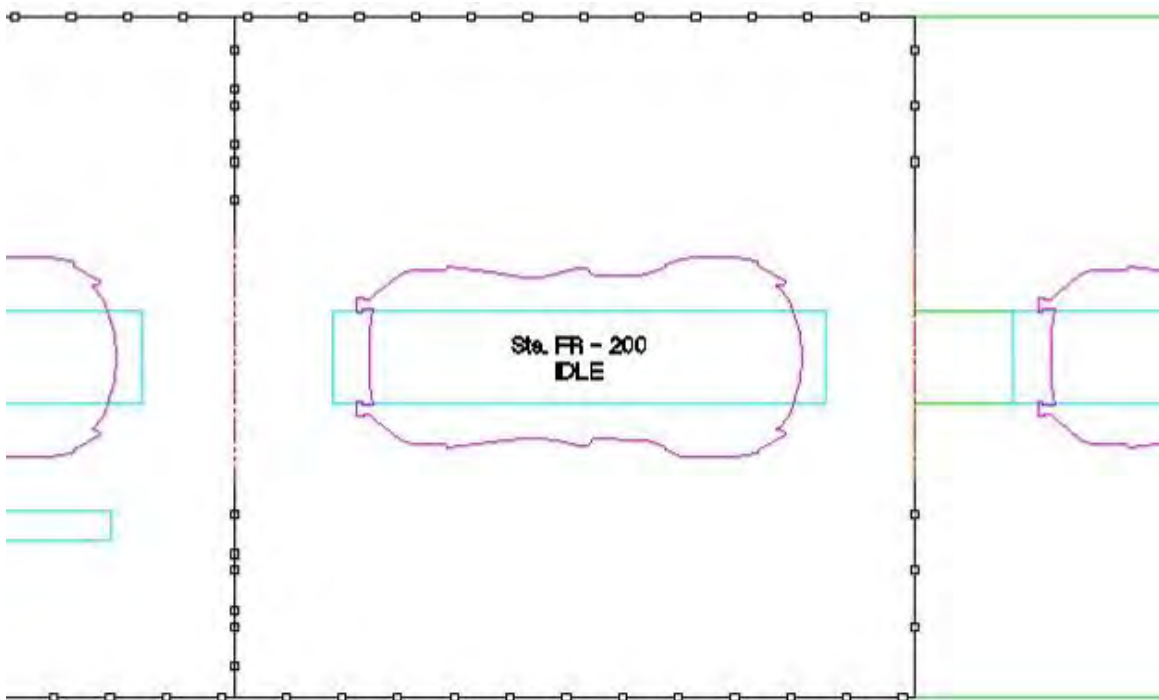

Figure 2.7.ar: Station FR200 assembly layout

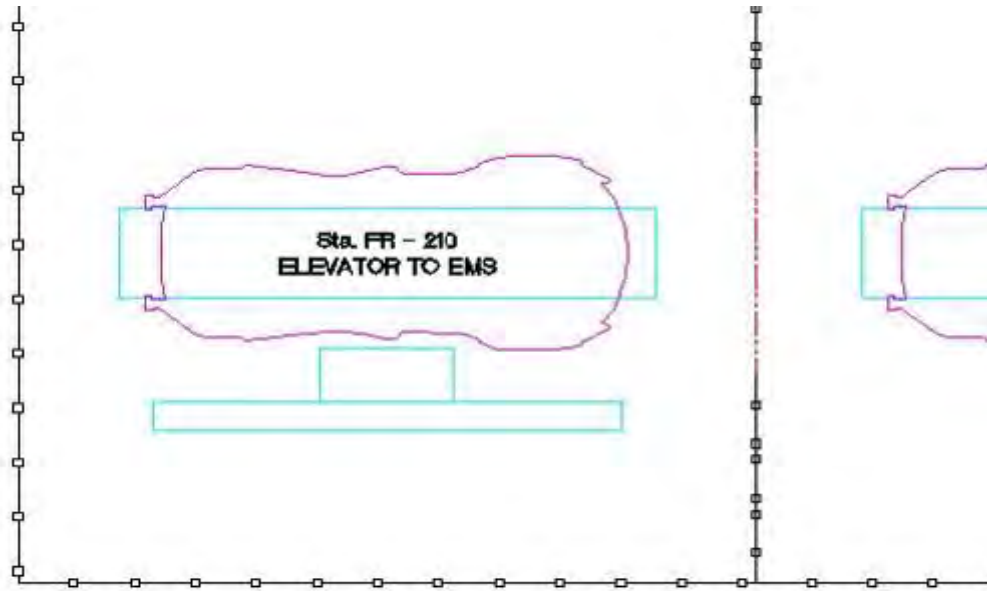

Figure 2.7.as: Station FR210 assembly layout

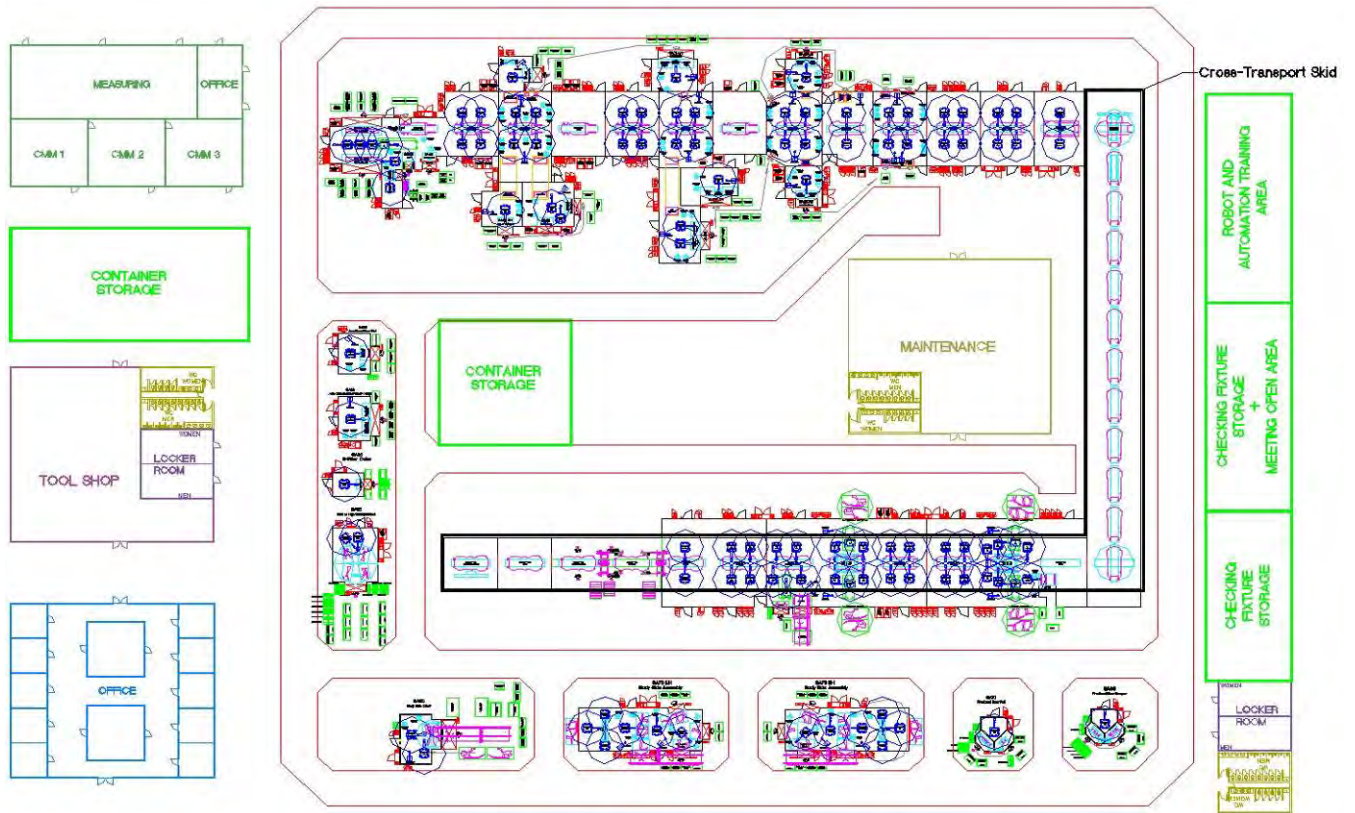

Figure 2.7.at: Overall body shop assembly layout

3.0 Facility

The total area required for the body shop is 190,000 ft², divided up into areas with different functions. A room will be allocated in the body shop to house the coordinate-measuring machine (CMM). The CMM is a specialized device that measures the geometric characteristics of an object and is used to test the dimensions of parts against their design intent. Other areas include a break room, locker room and restrooms, maintenance area, tool shop for repairs, and a logistic preparation area.

4.0 Labor Requirements

The body shop will require a well-trained work force to operate. This work force is categorized into direct and indirect workers. Direct workers handle assembly line tasks and other jobs directly linked to manufacturing. The body shop will require 24 direct workers per shift.

Indirect workers will also be required. They will perform tasks such as maintenance (10 workers per shift), logistics work (12 workers per shift), and there will be one CMM operator per shift.

A total of 47 workers will be required per shift.

5.0 Logistic Concept

This section will discuss the basic logistics of the plant. These logistics need to be factored in to prepare the plant to operate smoothly.

5.1 Main Features

All part bins and racks will be sized according to the size of the parts stored helping to ensure parts are stored in the proper location and maximizing usable space. There will be enough part bins to store parts for one week of production – approximately 1200 parts. This includes a two-day supply in the plant, two days for transportation, and one day at the supplier's plant.

Table 5.1.a below shows the total bins and racks necessary for storage and gives the total cost.

Table 5.1.a: Total bins and racks

| Part Number | Part Name | Length (mm) | Width (mm) | Height (mm) | Rack Vol. (m3) | Price/Rack | Rack/1200 Units | Price of Racks |
|---------------|--|-------------|------------|-------------|----------------|------------|-----------------|----------------|
| 7305-0900-137 | L, inner front frame rail transition | 803 | 223 | 344 | 0.062 | \$360 | 50 | \$18,000 |
| 7305-0900-138 | R, inner front frame rail transition | 803 | 223 | 344 | 0.062 | \$360 | 50 | \$18,000 |
| 7305-1100-220 | R, upper dash reinforcement | 398 | 270 | 382 | 0.041 | \$360 | 33 | \$11,880 |
| 7305-1100-221 | L, upper dash reinforcement | 398 | 270 | 382 | 0.041 | \$360 | 33 | \$11,880 |
| 7305-1110-101 | Center, rear seat riser | 1,423 | 93 | 208 | 0.027 | \$530 | 39 | \$20,670 |
| 7305-1130-145 | Cowl panel | 1,577 | 135 | 327 | 0.070 | \$270 | 57 | \$15,390 |
| 7305-1130-147 | Cowl panel reinforcement | 1,578 | 216 | 280 | 0.096 | \$360 | 80 | \$28,800 |
| 7305-1200-209 | L, outer front frame rail transition | 854 | 191 | 309 | 0.050 | \$530 | 71 | \$37,630 |
| 7305-1200-210 | R, outer front frame rail transition | 854 | 191 | 309 | 0.050 | \$530 | 71 | \$37,630 |
| 7305-1300-155 | L, upper, A-pillar inner panel | 551 | 70 | 524 | 0.020 | \$270 | 36 | \$9,720 |
| 7305-1300-156 | R, upper, A-pillar inner panel | 551 | 70 | 524 | 0.020 | \$270 | 36 | \$9,720 |
| 7305-1300-165 | L, rear shock tower | 486 | 302 | 325 | 0.048 | \$360 | 39 | \$14,040 |
| 7305-1300-166 | R, rear shock tower | 486 | 302 | 325 | 0.048 | \$360 | 39 | \$14,040 |
| 7305-1310-151 | L, front shock tower | 366 | 278 | 281 | 0.029 | \$270 | 50 | \$13,500 |
| 7305-1310-152 | R, front shock tower | 366 | 278 | 281 | 0.029 | \$270 | 50 | \$13,500 |
| 7305-1310-161 | L, front wheelhouse panel | 444 | 255 | 308 | 0.035 | \$530 | 50 | \$26,500 |
| 7305-1310-162 | R, front wheelhouse panel | 444 | 255 | 308 | 0.035 | \$530 | 50 | \$26,500 |
| 7305-1400-153 | L, lower A-pillar outer panel | 362 | 187 | 245 | 0.017 | \$270 | 29 | \$7,830 |
| 7305-1400-154 | R, lower A-pillar outer panel | 362 | 187 | 245 | 0.017 | \$270 | 29 | \$7,830 |
| 7305-1500-157 | L, shotgun inner panel | 885 | 53 | 369 | 0.017 | \$270 | 31 | \$8,370 |
| 7305-1500-158 | R, shotgun inner panel | 885 | 53 | 369 | 0.017 | \$270 | 31 | \$8,370 |
| 7305-1500-197 | L, upper, A-pillar inner reinforcement bracket | 152 | 81 | 144 | 0.020 | \$270 | 3 | \$810 |
| 7305-1500-198 | R, upper, A-pillar inner reinforcement bracket | 152 | 81 | 144 | 0.020 | \$270 | 3 | \$810 |
| 7305-1500-227 | L, lower, A-pillar inner reinforcement bracket | 143 | 96 | 100 | 0.010 | \$270 | 2 | \$540 |
| 7305-1500-228 | R, lower, A-pillar inner reinforcement bracket | 143 | 96 | 100 | 0.010 | \$270 | 2 | \$540 |
| 7305-1600-149 | Dash panel reinforcement | 1,464 | 306 | 611 | 0.274 | \$530 | 80 | \$42,400 |
| 7305-1600-183 | L, rear outer wheelhouse panel | 1,059 | 350 | 723 | 0.268 | \$530 | 80 | \$42,400 |
| 7305-1600-184 | R, rear outer wheelhouse panel | 1,059 | 350 | 723 | 0.268 | \$530 | 80 | \$42,400 |
| 7305-1900-159 | L, shotgun closeout panel | 102 | 3 | 90 | 0.000 | \$50 | 2 | \$100 |
| 7305-1900-160 | R, shotgun closeout panel | 102 | 3 | 90 | 0.000 | \$50 | 2 | \$100 |
| 7305-1930-169 | L, shotgun outer panel | 866 | 301 | 369 | 0.096 | \$360 | 80 | \$28,800 |
| 7305-1930-170 | R, shotgun outer panel | 866 | 301 | 369 | 0.096 | \$360 | 80 | \$28,800 |
| 7305-2100-104 | Rear roof header | 889 | 99 | 259 | 0.023 | \$530 | 32 | \$16,960 |
| 7305-2200-109 | Roof panel | 2,031 | 186 | 1,370 | 0.517 | \$660 | 100 | \$66,000 |
| 7306-0810-123 | L, rocker sill extrusion | 1,563 | 132 | 178 | 0.037 | \$530 | 11 | \$5,830 |
| 7306-0820-124 | R, rocker sill extrusion | 1,563 | 132 | 178 | 0.037 | \$530 | 11 | \$5,830 |
| 7306-0830-124 | R, front floor bracket | 90 | 57 | 53 | 0.000 | \$65 | 8 | \$522 |
| 7306-0830-124 | L, front floor bracket | 90 | 57 | 53 | 0.000 | \$65 | 8 | \$522 |
| 7306-0830-124 | R, floor bracket | 90 | 57 | 53 | 0.000 | \$65 | 8 | \$522 |
| 7306-0830-124 | L, floor bracket | 90 | 57 | 53 | 0.000 | \$65 | 8 | \$522 |



LOTUS ARB LWV PROGRAM

| | | | | | | | | |
|---------------|--|-------|-----|-------|-------|-------|-----|-----------|
| 7306-0830-125 | L, front floor X-member | 603 | 51 | 51 | 0.002 | \$65 | 44 | \$2,873 |
| 7306-0830-125 | R, front floor X-member | 603 | 51 | 51 | 0.002 | \$65 | 44 | \$2,873 |
| 7306-0830-125 | L, rear floor X-member | 603 | 51 | 51 | 0.002 | \$65 | 44 | \$2,873 |
| 7306-0830-125 | R, rear floor X-member | 603 | 51 | 51 | 0.002 | \$65 | 44 | \$2,873 |
| 7306-0830-126 | Front floor X-member transition | 274 | 45 | 100 | 0.001 | \$65 | 34 | \$2,220 |
| 7306-0830-126 | Rear floor X-member transition | 274 | 45 | 100 | 0.001 | \$65 | 34 | \$2,220 |
| 7306-0840-010 | L, mid floor bracket | 200 | 62 | 53 | 0.001 | \$50 | 57 | \$2,850 |
| 7306-0840-010 | R, mid floor bracket | 200 | 62 | 53 | 0.001 | \$50 | 57 | \$2,850 |
| 7306-0840-011 | L, mid floor X-member | 602 | 51 | 152 | 0.005 | \$360 | 4 | \$1,440 |
| 7306-0840-011 | R, mid floor X-member | 602 | 51 | 152 | 0.005 | \$360 | 4 | \$1,440 |
| 7306-0840-012 | Mid floor transition X-member | 276 | 146 | 100 | 0.004 | \$360 | 3 | \$1,080 |
| 7306-1000-175 | L, rear seat riser | 768 | 94 | 148 | 0.011 | \$200 | 11 | \$2,200 |
| 7306-1000-176 | R, rear seat riser | 768 | 94 | 148 | 0.011 | \$200 | 11 | \$2,200 |
| 7306-1110-103 | L, rear seat floor reinforcement | 350 | 44 | 97 | 0.001 | \$200 | 1 | \$200 |
| 7306-1110-104 | R, rear seat floor reinforcement | 350 | 44 | 97 | 0.001 | \$200 | 1 | \$200 |
| 7306-1130-143 | Dash panel | 1,501 | 587 | 785 | 0.692 | \$660 | 133 | \$87,780 |
| 7306-1200-113 | Rear seat floor panel | 1,396 | 68 | 815 | 0.077 | \$360 | 63 | \$22,680 |
| 7306-1910-189 | L, upper, A-pillar outer panel | 1,255 | 60 | 511 | 0.039 | \$200 | 39 | \$7,800 |
| 7306-1910-190 | R, upper, A-pillar outer panel | 1,255 | 60 | 511 | 0.039 | \$200 | 39 | \$7,800 |
| 7306-1910-195 | L, C-pillar outer | 1,392 | 163 | 863 | 0.196 | \$530 | 60 | \$31,800 |
| 7306-1910-196 | R, C-pillar outer | 1,392 | 163 | 863 | 0.196 | \$530 | 60 | \$31,800 |
| 7306-1913-001 | L, B-pillar quarter panel | 1,306 | 69 | 197 | 0.018 | \$200 | 18 | \$3,600 |
| 7306-1920-191 | L, roof side rail outer panel | 963 | 129 | 143 | 0.018 | \$200 | 18 | \$3,600 |
| 7306-1920-192 | R, roof side rail outer panel | 963 | 129 | 143 | 0.018 | \$200 | 18 | \$3,600 |
| 7306-1924-002 | R, B-pillar quarter panel | 1,306 | 69 | 197 | 0.018 | \$200 | 18 | \$3,600 |
| 7306-2000-171 | L, roof side rail inner panel | 1,203 | 48 | 470 | 0.027 | \$530 | 22 | \$11,660 |
| 7306-2000-172 | R, roof side rail inner panel | 1,203 | 48 | 470 | 0.027 | \$360 | 22 | \$7,920 |
| 7306-2000-215 | L, rear roof side rail inner panel | 951 | 155 | 186 | 0.027 | \$360 | 22 | \$7,920 |
| 7306-2000-216 | R, rear roof side rail inner panel | 951 | 155 | 186 | 0.027 | \$360 | 36 | \$12,960 |
| 7306-2100-101 | Front header panel | 1,344 | 179 | 183 | 0.044 | \$530 | 13 | \$6,890 |
| 7306-2100-103 | Center roof header | 1,154 | 59 | 162 | 0.011 | \$200 | 11 | \$2,200 |
| 7306-2300-185 | L, body side outer panel | 3,289 | 380 | 1,340 | 1.675 | \$790 | 240 | \$189,600 |
| 7306-2300-186 | R, body side outer panel | 3,289 | 380 | 1,340 | 1.675 | \$790 | 240 | \$189,600 |
| 7306-2300-187 | L, rear quarter panel closeout | 292 | 143 | 247 | 0.010 | \$200 | 10 | \$2,000 |
| 7306-2300-188 | R, rear quarter panel closeout | 292 | 143 | 247 | 0.010 | \$200 | 10 | \$2,000 |
| 7306-2300-189 | L, outer liftgate flange channel to body | 610 | 79 | 96 | 0.005 | \$200 | 5 | \$1,000 |
| 7306-2300-190 | R, outer liftgate flange channel to body | 610 | 79 | 96 | 0.005 | \$200 | 5 | \$1,000 |
| 7306-2300-191 | L, rear body taillamp closeout | 173 | 97 | 127 | 0.002 | \$270 | 4 | \$1,080 |
| 7306-2300-192 | R, rear body taillamp closeout | 173 | 97 | 127 | 0.002 | \$270 | 4 | \$1,080 |
| 7306-2400-229 | L, center floor panel | 1,252 | 710 | 60 | 0.053 | \$530 | 16 | \$8,480 |
| 7306-2400-230 | R, center floor panel | 1,252 | 710 | 60 | 0.053 | \$530 | 16 | \$8,480 |
| 7306-2400-231 | Rear X-member component | 934 | 185 | 155 | 0.027 | \$360 | 22 | \$7,920 |
| 7307-0900-141 | L, rear frame rail inner transition | 1,006 | 182 | 290 | 0.053 | \$530 | 16 | \$8,480 |
| 7307-0900-142 | R, rear frame rail inner transition | 1,006 | 182 | 290 | 0.053 | \$530 | 16 | \$8,480 |



LOTUS ARB LWV PROGRAM

| | | | | | | | | |
|------------------|-------------------------------------|-------|-----|-----|-------|-------|--------------|--------------------|
| 7307-1000-139 | L, rear frame rail | 700 | 70 | 129 | 0.006 | \$270 | 11 | \$2,970 |
| 7307-1000-140 | R, rear frame rail | 700 | 70 | 129 | 0.006 | \$270 | 11 | \$2,970 |
| 7307-1020-135 | L, front frame rail | 574 | 70 | 133 | 0.005 | \$270 | 9 | \$2,430 |
| 7307-1020-136 | R, front frame rail | 574 | 70 | 133 | 0.005 | \$270 | 9 | \$2,430 |
| 7307-1020-223 | L, frame rail mounting plate | 236 | 20 | 134 | 0.001 | \$65 | 17 | \$1,110 |
| 7307-1020-224 | R, frame rail mounting plate | 236 | 20 | 134 | 0.001 | \$65 | 17 | \$1,110 |
| 7307-1200-217 | L, rear frame rail outer transition | 1,006 | 198 | 273 | 0.054 | \$530 | 16 | \$8,480 |
| 7307-1200-218 | R, rear frame rail outer transition | 1,006 | 198 | 273 | 0.054 | \$530 | 16 | \$8,480 |
| 7307-1400-163 | L, rear inner wheelhouse panel | 1,378 | 240 | 697 | 0.231 | \$530 | 71 | \$37,630 |
| 7307-1400-164 | R, rear inner wheelhouse panel | 1,378 | 240 | 697 | 0.231 | \$530 | 71 | \$37,630 |
| 7307-1500-111 | Rear end outer panel | 1,396 | 290 | 405 | 0.164 | \$530 | 50 | \$26,500 |
| 7307-1500-167 | L, rear shock tower reinforcement | 277 | 126 | 262 | 0.009 | \$200 | 9 | \$1,800 |
| 7307-1500-168 | R, rear shock tower reinforcement | 277 | 126 | 262 | 0.009 | \$200 | 9 | \$1,800 |
| 7307-1510-117 | Rear end panel | 1,495 | 367 | 398 | 0.218 | \$660 | 41 | \$27,060 |
| 7307-1600-213 | L, rear wheelhouse inner panel | 529 | 20 | 300 | 0.003 | \$200 | 3 | \$600 |
| 7307-2110-105 | L, D-pillar inner panel | 984 | 89 | 326 | 0.028 | \$360 | 23 | \$8,280 |
| 7307-2110-106 | R, D-pillar inner panel | 984 | 89 | 326 | 0.028 | \$360 | 23 | \$8,280 |
| 7307-2110-177 | L, D-pillar quarter panel inner | 516 | 220 | 331 | 0.038 | \$360 | 31 | \$11,160 |
| 7307-2110-179 | L, liftgate reinforcement panel | 653 | 151 | 364 | 0.036 | \$360 | 29 | \$10,440 |
| 7307-2110-180 | R, liftgate reinforcement panel | 653 | 151 | 364 | 0.036 | \$360 | 29 | \$10,440 |
| 7307-2120-178 | R, D-pillar quarter panel inner | 516 | 220 | 331 | 0.038 | \$360 | 31 | \$11,160 |
| | L, B-pillar reinforcement | 450 | 73 | 139 | 0.005 | \$200 | 5 | \$1,000 |
| | R, B-pillar reinforcement | 450 | 73 | 139 | 0.005 | \$200 | 5 | \$1,000 |
| | L, B-pillar upper brace | 354 | 165 | 224 | 0.013 | \$360 | 11 | \$3,960 |
| | R, B-pillar upper brace | 354 | 165 | 224 | 0.013 | \$360 | 11 | \$3,960 |
| | L, B-pillar bracket inner | 193 | 89 | 129 | 0.002 | \$270 | 4 | \$1,080 |
| | R, B-pillar bracket inner | 193 | 89 | 129 | 0.002 | \$270 | 4 | \$1,080 |
| | L, B-pillar inner panel | 1,152 | 130 | 504 | 0.076 | \$530 | 23 | \$12,190 |
| | R, B-pillar inner panel | 1,152 | 130 | 504 | 0.076 | \$530 | 23 | \$12,190 |
| | Rear floor panel | 932 | 126 | 714 | 0.084 | \$530 | 25 | \$13,250 |
| | R, rear wheelhouse inner panel | 529 | 20 | 300 | 0.003 | \$270 | 6 | \$1,620 |
| | L, rear shock tower reinforcement | 348 | 129 | 277 | 0.012 | \$200 | 13 | \$2,600 |
| | R, rear shock tower reinforcement | 348 | 129 | 277 | 0.012 | \$200 | 13 | \$2,600 |
| 7305-2400-209 | Front module | 1,200 | 507 | 250 | 0.152 | \$530 | 46 | \$24,380 |
| 7305-2410-000 | Front bumper | 1,630 | 300 | 300 | 0.147 | \$530 | 44 | \$23,320 |
| 7305-2430-000 | Rear bumper | 1,630 | 300 | 300 | 0.147 | \$530 | 44 | \$23,320 |
| Sub-Total | | | | | | | 3,946 | \$1,707,720 |
| Contingency | | | | | | | 20% | \$341,544 |
| Forklift | | | | | | | | \$200,000 |
| Other | | | | | | | | \$50,000 |
| Total | | | | | | | | \$2,299,264 |

The preparation area will be located close to the assembly line and will provide a connection from the line to the warehouse. Aisles in the plant will be organized and sized to fit their function. Main aisles will be 15 feet wide, logistic aisles will be 12 feet wide, and maintenance aisles will be 6.5 feet wide. All aisles will be two-way to ensure more efficient traffic flow.

Figure 5.1.a below shows the forklifts necessary in the factory.

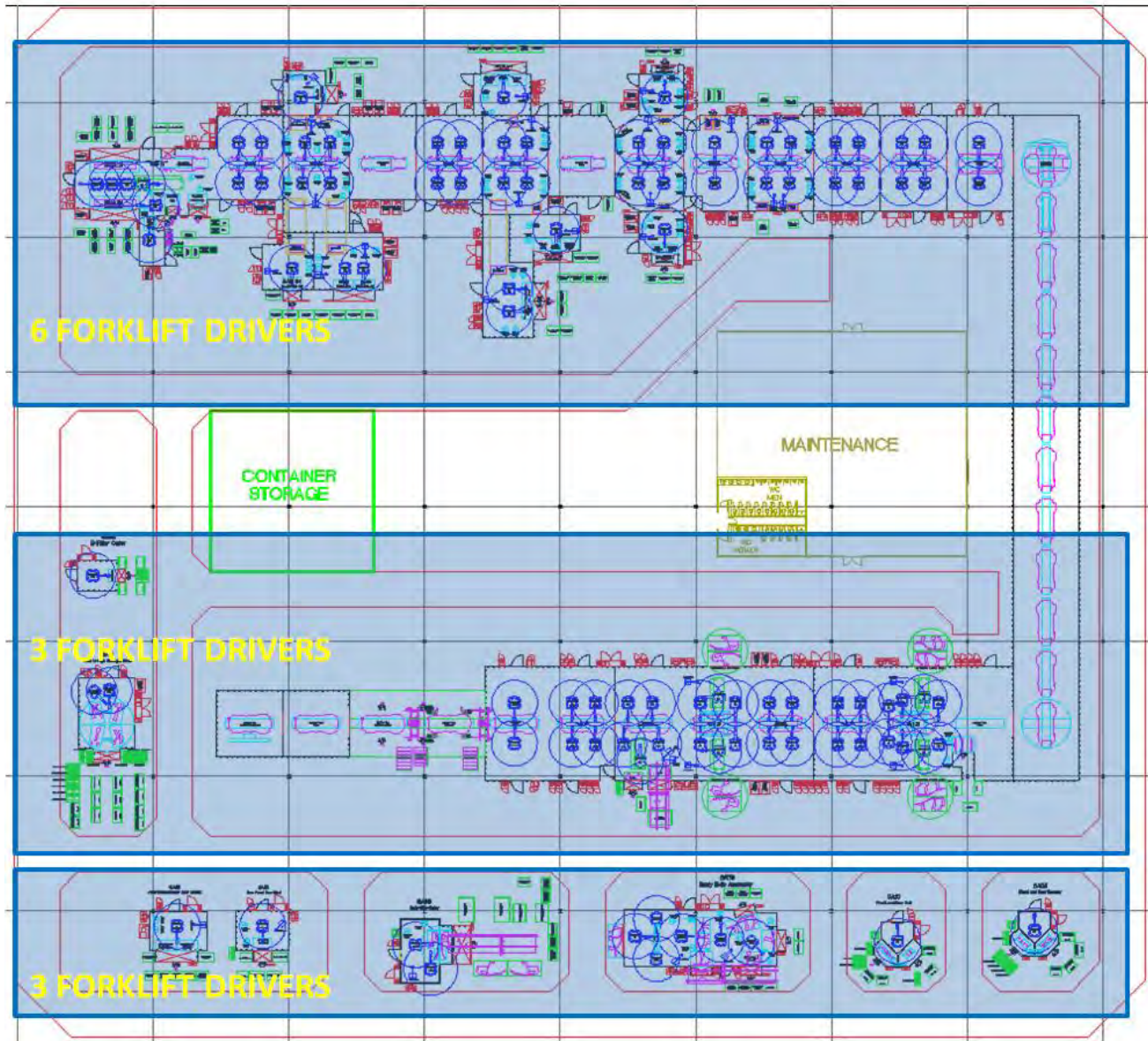

Figure 5.1.a: Forklift factory scope

Other logistic concepts include shooter technology employed for small parts and forklifts used for transportation.



Figure 5.1.b: Shoot technology used to transport small parts

5.2 Staff Needed

The staff requirement has been incorporated into the labor requirements section of this report (section 4.0). The total number of workers needed for logistics work is 12 forklift drivers per shift.

6.0 Quality Concept

6.1 Philosophy

Ensuring quality products isn't relegated to a sole person, but rather, it's the responsibility of everyone at the plant. Each team member working at the plant is responsible for maintaining quality work in order to build the highest quality product. Team members are responsible for stopping the assembly line when a defect is noticed and must report the defect for quality measurement and analysis.

There will be a quality control team that analyzes the product to determine quality, defines methods to improve quality, and trains the factory workers on how to build vehicles that

meet the defined quality. All of the reported defects will be documented for analysis and further quality refinement.

Figure 6.1.a below shows the quality management concept and responsibilities of each team member.



Figure 6.1.a: Plant quality management concept

6.2 Quality Assurance Methods

In order to measure and assess product quality, there will be two different quality checks. One check will be performed 'in-line' as the vehicles are moving down the assembly line and the other will be performed 'off-line' once the vehicle or part is assembled.

6.2.1 In-Line Quality Check

There will be four in-line vision stations equipped with cameras to provide quality data and monitor processes. Each vision station is equipped with two cameras attached to robotic arms to increase the visible area. A single camera can track 50 different locations on the

part at each station, giving the capability to track 100 different locations per station simultaneously.

Table 6.2.1.a below gives the names of each station, the location, and the part of the vehicle being monitored.

Table 6.2.1.a: Vision quality stations, location, and part monitored

| Station Name | Location | Vehicle Part Monitored |
|---------------------|---------------------------------|-------------------------------|
| UB-220 | End of underbody line | Underbody |
| SA-70L | End of left-hand bodyside line | Left-hand bodyside |
| SA-70R | End of right-hand bodyside line | Right-hand bodyside |
| FR-170 | End of framing line | Vehicle frame |

6.2.2 Off-Line Quality Check

In order to analyze and improve the manufacturing quality and overall quality of the end product, the body shop is equipped with a coordinate-measuring-machine room. The room contains three coordinate measuring machines (CMM) – two with one ten-foot robotic arm and the third has two, 20-foot arms. The CMMs take measurements along the X, Y, and Z axes of the part and are accurate to around one micron, ensuring a high degree of accuracy. These extremely accurate measurements are then used to determine the precision of the manufacturing process and quality of the parts. A method such as Six Sigma can then be used to further refine and improve the precision of the manufacturing process.

These off-line quality checks will be performed on one underbody per shift (two inspections per day) and on one full BIW per two shifts (one per day).

7.0 Maintenance Concept

As with any maintenance concept, the idea is to perform preventative maintenance to ensure as much uptime as possible in the plant to increase output and avoid costly delays. Preventative maintenance also helps to ensure better quality products as it will keep the machines and tools in optimum operating condition. Preventative maintenance can also help reduce overall maintenance costs as it can help reduce breakdowns and emergency maintenance.

Maintenance schedules will initially be determined using historical data to project the lifespan, wear rate, and mis-calibration rate of machinery and tools. Based on the historical data, daily, weekly, monthly, quarterly, and yearly maintenance schedules will be determined. As the plant becomes operational and runs, data will be collected to refine the maintenance schedules in a continuous improvement process. The data will be collected by examining the machines in person and with the proper analytical tools if necessary. This way, damaged areas or areas of faster or slower wear can be determined and the maintenance schedules adjust accordingly. Through these examinations, remaining tool and machine lifetimes can be determined and planned for financially and with expected plant downtime.

Electronic problems will be minimized using diagnostic tools and debugging software to find and eliminate problems as they occur.

There will of course be unexpected maintenance necessary when a machine or tool fails unexpectedly and these situations will be handled accordingly.

Figure 7.0.a below shows the plant layout and anticipated maintenance personnel necessary and the specific areas of the plant they would be responsible for.

Figure 7.0.a: Maintenance personnel and coverage

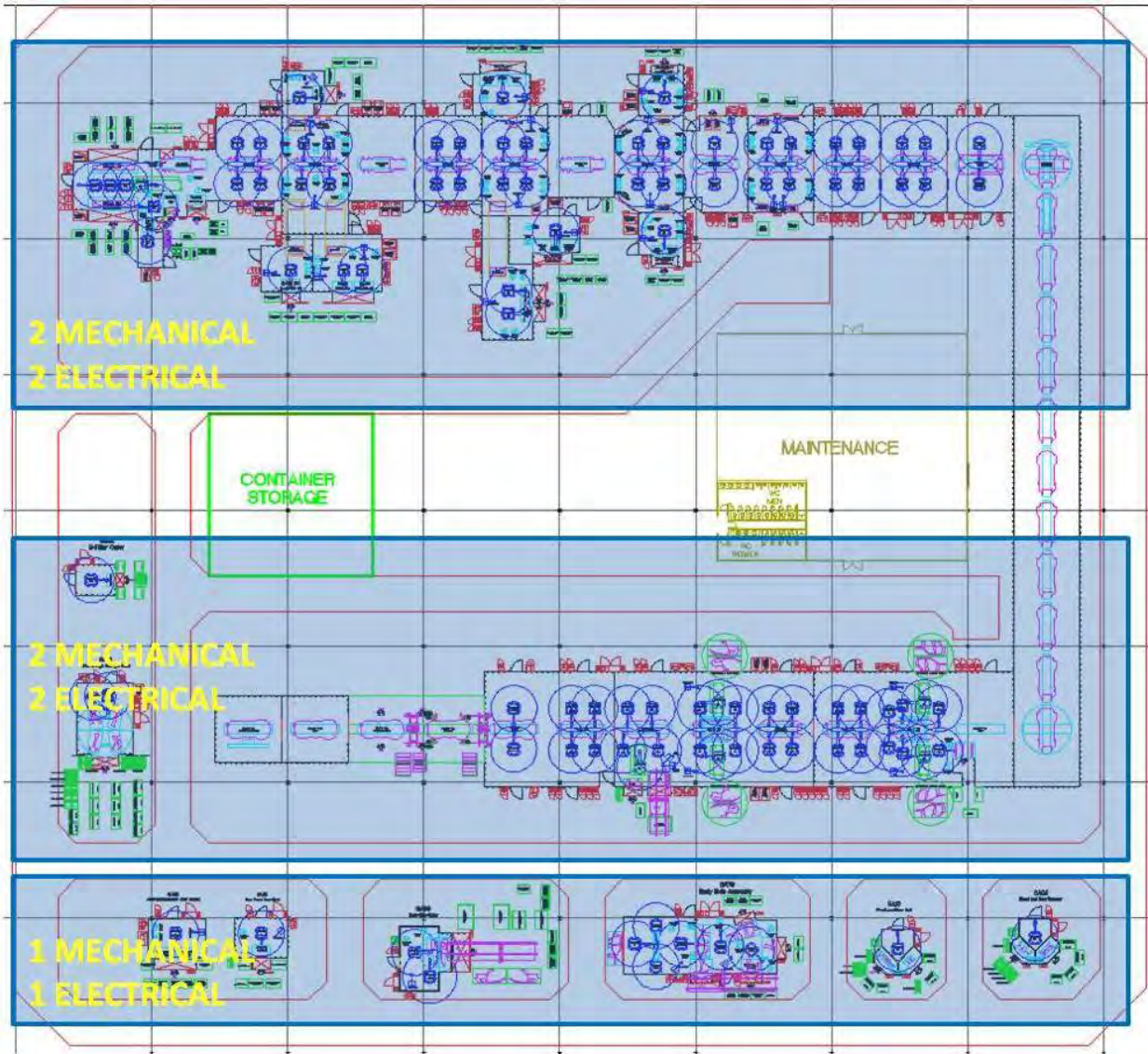

8.0 Environmental Assumptions

In keeping with the environmentally friendly idea behind the lightweight Phase 2 HD vehicle, the plant was designed to minimize the impact on the environment. Some of the concepts noted here are already being implemented, including on a number of EBZ-designed plants in Europe. Subaru's manufacturing facility in Indiana is also a noteworthy environmentally friendly automotive plant that creates electrical power (through burning) or recycles all waste. This section explains several of the environmentally friendly designs chosen for the plant. These options however, were not used in the cost portion of the analysis; rather, current widely available energy sources were used to provide a direct comparison.

8.1 Solar Panels

Solar panels are a great way for automotive manufacturing plants to produce their own energy as the panels can easily be integrated into the plant's large roof structure. This means that the solar panels require no additional land for installation and instead make use of a normally vacant space. With the correct location, the solar panels will receive regular exposure to the sunlight for optimum performance, which allows for freedom in plant location as it can be more remotely situated due to its in-house power supply. Once the initial investment on the solar panels is paid off, they will provide nearly free energy as they require little maintenance.

There are however, a number of disadvantages to using solar panels such as the high initial investment. A number of States, along with the Federal Government however, will refund the entire cost of purchasing and installing solar panels, and with solar renewable energy credits and the possible positive impact on the electrical grid (sell energy back to the utility companies), solar panels are highly desired. As the solar panels require sun to gather energy, they do not operate at night and their performance can be reduced by air pollution and cloud cover which means a high-energy battery or capacitor would be required in the event of such situations or the plant would pull energy from the grid.

8.2 Wind Turbines

Another clean way of producing power is using wind turbines, which like the solar panels, can be installed on the roof of the manufacturing facility, maximizing usable space and eliminating the need for extra land. The wind turbines to be installed on the plant's roof however, must be small scale in order for the plant to support them.

Like the solar panels, wind turbines have a few disadvantages. They do not operate with no wind (the plant's location should minimize this) and require a high initial investment. This however, will be refunded by the state of Washington through taxes and the possible positive energy impact could make them profitable.

8.3 Biomass Power

Rather than disposing of biomass and shipping it to a landfill, employees will be instructed to dispose of it in designated receptacles. The contents of these receptacles will then be burned for power generation, eliminating some of the waste normally destined for landfills and generating power as well.

8.4 Water Recycle

Rain water normally goes unused and is returned to the ground, but this essentially free water can be very useful and help to reduce costs if captured. The plant will utilize a rain water recycle where the water is captured on the roof of the plant along with other various structures and locations on site and then used for cooling and in toilets. Gray water (used sink water, drinking fountains, etc.) is typically sent to a water treatment plant and treated, but this water is partially clean and fit for reuse in toilets.

8.5 Lighting

In order to reduce energy consumption at the plant, the lighting will all be LEDs. Using LEDs will decrease lighting energy costs and will also decrease maintenance costs as high-quality LEDs have a lifespan of over 100,000 hours. These LED lighting fixtures will last for over 25 years operating 16 hours per day and 250 days per year.

8.6 Recycling, Reusables, and Returnables

There will be designated recycling and returnable bins for employees and nearly every material in the plant will either be recycled or reused to further reduce the amount of waste generated. Glass, plastic, metal, and paper recycling bins will be available for employees to recycle their own materials.

Materials and components in the plant itself will be reused wherever possible. This includes items as large as recycling normally scrap steel and plastic to make other components to items as small as saving protective plastic covers on items like air conditioning compressors. Covers like those – along with styrofoam protective pieces – will

be saved and shipped back to suppliers for reuse. After the parts have been reused a certain number of times and reached their usable life, they will be recycled.

The pallets used in the manufacturing process will be reused and rebuilt if damaged. If the part isn't salvageable, it will be shredded and turned into mulch.

8.7 Living Roof

The roof of the Phase 2 HD vehicle plant will be a 'living roof,' where sedum plants are installed on the roof to help insulate the building. The energy-generating solar panels and wind turbines will be installed around the sedum plants. In addition to helping insulate the plant, the sedum plants will scrub carbon dioxide from the air and emit oxygen, improving the atmosphere. These roofs are already in use on plants such as Ford's Rouge River Plant and Rolls-Royce's Goodwood facility.

8.8 Solvent Recovery

Solvent recovery both saves the environment and saves the plant from dealing with toxic waste disposal, which will recover the initial investment over a number of years. This system captures and breaks down all paint solvents into basic components, which are then reused.

8.9 Plant Surroundings

The Phase 2 HD vehicle plant will be built around the existing natural habitat rather than flattening hundreds of acres to build the plant. Some land will have to be cleared to construct the factory, but a wildlife conservation area will be built up after the factory is constructed to replace any of the habitat displaced and to redevelop previously deforested land.

9.0 Investment/Costs

All of the necessary costs to get the factory up and running, build the BIWs, and operate the factory on a daily basis are covered in this section. These costs include capital costs, labor costs, utilities, SG&A, interest payments, and freight. The initial BIW cost analysis is done assuming production of 60,000 vehicles per year, but a sensitivity analysis was conducted based on production of 100,000, 200,000, and 400,000 vehicles per year.

9.1 Capital Costs

Capital costs for the Phase 2 HD BIW plant are broken up into seven main areas – sub-assembly line, underbody line, framing line, tool shop, transport conveyors, storage bins and racks, and the coordinate measuring machine. Tables 9.1.a-9.1.p below detail the investment necessary for the assembly lines and tool shop. The investment for bins and racks was detailed in section 6.1 and is a total of \$2.3 million, transport conveyors cost \$3.5 million, and the CMM is \$2.4 million. All of these investments are amortized over 5 years except the CMM, which is amortized over 7 years.

Table 9.1.a: Sub-assembly tooling costs

| Tooling | | | | | | | |
|---------------|------------------|------------------|----------------------|--------------------|-------------------------|------------------|--------------------|
| Station | Mechanical Costs | Controller Costs | Purchased Items Cost | Construction Labor | Controller Installation | Testing | Total |
| SA05 | \$18,270 | \$4,140 | \$28,200 | \$64,800 | \$10,500 | \$6,000 | \$131,910 |
| SA10 | \$16,620 | \$4,140 | \$24,000 | \$50,460 | \$8,460 | \$5,400 | \$109,080 |
| SA15 | \$30,360 | \$8,100 | \$58,500 | \$86,550 | \$22,200 | \$12,000 | \$217,710 |
| SA20 | \$23,100 | \$4,200 | \$21,000 | \$33,300 | \$13,500 | \$5,700 | \$100,800 |
| SA25 | \$33,720 | \$9,600 | \$53,000 | \$87,600 | \$19,500 | \$9,000 | \$212,420 |
| SA30 | \$21,000 | \$10,500 | \$20,000 | \$38,280 | \$16,300 | \$4,200 | \$110,280 |
| SA35 | \$24,900 | \$7,200 | \$27,000 | \$60,000 | \$20,700 | \$10,500 | \$150,300 |
| SA40-R | \$35,100 | \$5,700 | \$38,700 | \$79,140 | \$25,200 | \$14,100 | \$197,940 |
| SA40-L | | | \$38,700 | \$79,140 | \$25,200 | \$14,100 | \$157,140 |
| SA45 | \$26,400 | \$5,400 | \$32,000 | \$68,400 | \$14,940 | \$7,800 | \$154,940 |
| SA50-55 | \$42,000 | \$6,600 | \$36,000 | \$102,900 | \$29,700 | \$12,900 | \$230,100 |
| SA60 | \$37,800 | \$10,200 | \$41,000 | \$115,920 | \$29,400 | \$12,600 | \$246,920 |
| SA65-R | \$34,300 | \$6,750 | \$55,200 | \$88,500 | \$19,500 | \$10,400 | \$214,650 |
| SA65-L | | | \$55,200 | \$88,500 | \$19,500 | \$10,400 | \$173,600 |
| SA70-R | \$121,800 | \$19,800 | \$190,000 | \$281,040 | \$108,000 | \$68,000 | \$788,640 |
| SA70-L | | | \$190,000 | \$281,040 | \$108,000 | \$68,000 | \$647,040 |
| SA75-R | \$22,800 | \$5,100 | \$39,200 | \$75,420 | \$21,000 | \$11,500 | \$175,020 |
| SA75-L | | | \$39,200 | \$75,420 | \$21,000 | \$11,500 | \$147,120 |
| SA80 | \$27,000 | \$6,240 | \$73,000 | \$136,020 | \$31,500 | \$17,100 | \$290,860 |
| SA85 | \$16,500 | \$5,500 | \$18,500 | \$44,500 | \$8,500 | \$8,000 | \$101,500 |
| Totals | \$531,670 | \$119,170 | \$1,078,400 | \$1,936,930 | \$572,600 | \$319,200 | \$4,557,970 |

Table 9.1.b: Sub-assembly capital tooling costs

| Capital Tooling | | | | | |
|--|------------------|------------------|----------------------|--------------------|--------------------|
| Description | Mechanical Costs | Controller Costs | Purchased Items Cost | Construction Labor | Total |
| Safety fence, gates, curtains | \$55,600 | \$19,800 | \$281,200 | \$136,130 | \$492,730 |
| Robot simulation, programming, dress | \$197,100 | \$306,400 | \$115,500 | \$42,280 | \$661,280 |
| System layout and installation drawing | \$67,200 | | | | \$67,200 |
| Weld controllers | | | \$49,500 | \$1,080 | \$50,580 |
| Weld guns | | | \$55,500 | \$2,340 | \$57,840 |
| E/E changers | | | \$629,350 | \$68,880 | \$698,230 |
| Tip dresser/torch cleaner | \$1,800 | | \$17,500 | \$7,500 | \$26,800 |
| Air/water headers and valves | | | \$229,720 | \$46,800 | \$276,520 |
| Electronics and cables for operation | | \$329,000 | \$502,000 | \$188,000 | \$1,019,000 |
| Dispensing equipment | | | \$1,200,000 | \$51,200 | \$1,251,200 |
| Gravity conveyors | | | \$6,600 | \$900 | \$7,500 |
| Balconies and overhead structure | | | | | \$0 |
| Transfer system | | | \$72,000 | \$27,000 | \$99,000 |
| Welding robots (mig/braze) | | | \$204,000 | \$6,300 | \$210,300 |
| Materials handling robots | | | \$1,650,000 | \$62,700 | \$1,712,700 |
| Spir units | | | \$90,000 | \$1,200 | \$91,200 |
| Dispensing robots | | | \$80,000 | \$4,200 | \$84,200 |
| Tri-axis trunnion units | | | \$18,000 | \$3,500 | \$21,500 |
| Rivtac system | | | \$700,000 | \$8,400 | \$708,400 |
| Manipulators/load assists | \$30,400 | | \$39,400 | \$32,000 | \$101,800 |
| FSJ system | | | \$1,200,000 | \$10,800 | \$1,210,800 |
| DC nut runners B/UP style | | | \$112,000 | \$6,000 | \$118,000 |
| Vision system | | | \$600,000 | \$20,000 | \$620,000 |
| System lighting | | | \$82,000 | \$50,700 | \$132,700 |
| Index tables | \$16,000 | | \$112,000 | \$46,000 | \$174,000 |
| Pedestal welders | | | \$60,000 | \$4,500 | \$64,500 |
| Total | \$368,100 | \$655,200 | \$8,106,270 | \$828,410 | \$9,957,980 |

Table 9.1.c: Sub-assembly miscellaneous costs

| Miscellaneous Costs | | |
|-----------------------------------|--------------------|---|
| Description | Cost | Remarks |
| Crating and loading | \$71,500 | |
| Freight | \$200,000 | |
| Training @ EBZ USA | | One, eight-hour training day included. More time quoted on request |
| Operation and maintenance manuals | \$38,500 | |
| 20-hour test run | \$36,500 | |
| 30-piece capability study | \$550,000 | Dependent on product availability. Includes dimensional assemblies and weld integrity testing |
| 300-piece test-part buy-off | \$234,000 | Dependent on product availability |
| 12-month warranty | Included | |
| Installation | \$731,000 | Complete system integration in customer plant using EBZ personnel |
| Installation supervision | \$58,000 | Supervision only using EBZ personnel |
| Startup assistance | \$386,000 | Includes two weeks with EBZ personnel, excluding expenses |
| Design Processing | | Cycle charts, weld studies, and miscellaneous process activities |
| Total | \$2,305,500 | |

Table 9.1.d: Grand total sub-assembly investment

| | |
|-------------------------------|---------------------|
| Total tooling cost | \$4,557,970 |
| Total capital tooling cost | \$9,957,980 |
| Total miscellaneous item cost | \$2,305,500 |
| Grand total | \$16,821,450 |

Table 9.1.e: Underbody tooling costs

| Tooling | | | | | | | |
|---------------|------------------|------------------|----------------------|--------------------|-------------------------|------------------|--------------------|
| Station | Mechanical Costs | Controller Costs | Purchased Items Cost | Construction Labor | Controller Installation | Testing | Total |
| UB100 | \$14,160 | \$3,900 | \$6,500 | \$58,500 | \$6,300 | \$8,700 | \$98,060 |
| UB110 | \$54,000 | \$7,500 | \$80,500 | \$123,900 | \$33,660 | \$17,100 | \$316,660 |
| UB120 | \$76,200 | \$17,400 | \$98,400 | \$196,740 | \$61,800 | \$20,160 | \$470,700 |
| UB130 | \$4,500 | \$2,500 | \$6,500 | \$17,500 | \$3,200 | \$4,400 | \$38,600 |
| UB140 | \$27,000 | \$3,750 | \$31,000 | \$47,500 | \$13,500 | \$12,500 | \$135,250 |
| UB150 | \$50,290 | \$11,500 | \$64,900 | \$129,400 | \$41,000 | \$14,000 | \$311,090 |
| UB160 | \$4,500 | \$2,500 | \$6,500 | \$17,500 | \$3,200 | \$4,400 | \$38,600 |
| UB170 | \$62,100 | \$14,100 | \$82,000 | \$156,000 | \$50,700 | \$16,500 | \$381,400 |
| UB180 | \$26,400 | \$4,500 | \$18,500 | \$43,080 | \$18,720 | \$9,600 | \$120,800 |
| UB190 | \$67,800 | \$14,400 | \$93,000 | \$174,000 | \$52,980 | \$18,000 | \$420,180 |
| UB200 | \$27,000 | \$3,750 | \$31,000 | \$47,500 | \$13,500 | \$12,500 | \$135,250 |
| UB210 | \$27,000 | \$3,750 | \$31,000 | \$47,500 | \$13,500 | \$12,500 | \$135,250 |
| UB220 | \$18,000 | \$3,750 | \$31,000 | \$47,500 | \$13,500 | \$12,500 | \$126,250 |
| Totals | \$458,950 | \$93,300 | \$580,800 | \$1,106,620 | \$325,560 | \$162,860 | \$2,728,090 |

Table 9.1.f: Underbody capital tooling costs

| Capital Tooling | | | | | |
|--|------------------|------------------|----------------------|--------------------|--------------------|
| Description | Mechanical Costs | Controller Costs | Purchased Items Cost | Construction Labor | Total |
| Safety fence, gates, curtains | \$52,200 | \$17,500 | \$235,000 | \$105,000 | \$409,700 |
| Robot simulation, programming, dress | \$207,900 | \$323,400 | \$126,000 | \$49,680 | \$706,980 |
| System layout and installation drawing | \$58,800 | | | | \$58,800 |
| Weld controllers | | | | | \$0 |
| Weld guns | | | | | \$0 |
| E/E changers | | | \$506,550 | \$55,440 | \$561,990 |
| Tip dresser/torch cleaner | | | | | \$0 |
| Air/water headers and valves | | | \$129,250 | \$157,000 | \$286,250 |
| Electronics and cables for operation | | \$166,000 | \$242,000 | \$79,200 | \$487,200 |
| Dispensing equipment | | | \$675,000 | \$28,000 | \$703,000 |
| Gravity conveyors | | | | | \$0 |
| Balconies and overhead structure | | | | | \$0 |
| Transfer system | \$31,500 | \$5,500 | \$143,000 | \$206,700 | \$386,700 |
| Welding robots (mig/braze) | | | | | \$0 |
| Materials handling robots | | | \$1,980,000 | \$75,600 | \$2,055,600 |
| Spir units | | | \$360,000 | \$4,800 | \$364,800 |
| Dispensing robots | | | | | \$0 |
| Seventh axis units | | | \$81,000 | \$5,100 | \$86,100 |
| Rivtac system | | | \$400,000 | \$4,800 | \$404,800 |
| Manipulators/load assists | | | | | \$0 |

| | | | | | |
|---------------------------|------------------|------------------|--------------------|------------------|--------------------|
| FSJ system | | | \$2,400,000 | \$21,600 | \$2,421,600 |
| DC nut runners B/UP style | | | | | \$0 |
| Vision system | | | \$300,000 | \$10,000 | \$310,000 |
| System lighting | | | \$31,000 | \$20,000 | \$51,000 |
| Index tables | | | | | \$0 |
| Pedestal welders | | | | | \$0 |
| Flow screw drive units | | | \$35,500 | \$6,500 | \$42,000 |
| Stud insertion units | | | \$125,000 | \$16,000 | \$141,000 |
| Totals | \$350,400 | \$512,400 | \$7,769,300 | \$845,420 | \$9,477,520 |

Table 9.1.g: Underbody miscellaneous costs

| Miscellaneous Costs | | |
|-----------------------------------|--------------------|---|
| Description | Cost | Remarks |
| Crating and loading | \$46,800 | |
| Freight | \$78,000 | |
| Training @ EBZ USA | | One, eight-hour training day included. More time quoted on request |
| Operation and maintenance manuals | \$25,000 | |
| 20-hour test run | \$14,500 | |
| 30-piece capability study | \$345,000 | Dependent on product availability. Includes dimensional assemblies and weld integrity testing |
| 300-piece test-part buy-off | \$155,000 | Dependent on product availability |
| 12-month warranty | Included | |
| Installation | \$485,000 | Complete system integration in customer plant using EBZ personnel |
| Installation supervision | \$45,000 | Supervision only using EBZ personnel |
| Startup assistance | \$125,000 | Includes two weeks with EBZ personnel, excluding expenses |
| Design Processing | | Cycle charts, weld studies, and miscellaneous process activities |
| Total | \$1,319,300 | |

Table 9.1.h: Grand total underbody investment

| | |
|--------------------------------------|---------------------|
| Total tooling cost | \$2,728,090 |
| Total capital tooling cost | \$9,477,520 |
| Total miscellaneous item cost | \$1,319,300 |
| Grand total | \$13,524,910 |

Table 9.1.i: Framing tooling costs

| Tooling | | | | | | | |
|---------------|------------------|------------------|----------------------|--------------------|-------------------------|------------------|--------------------|
| Station | Mechanical Costs | Controller Costs | Purchased Items Cost | Construction Labor | Controller Installation | Testing | Total |
| FR100 | \$1,800 | \$1,200 | \$4,500 | \$3,200 | \$2,400 | \$1,800 | \$14,900 |
| FR110 | \$91,140 | \$20,160 | \$187,200 | \$205,000 | \$84,600 | \$28,500 | \$616,600 |
| FR120 | \$18,000 | \$3,750 | \$31,000 | \$47,500 | \$13,500 | \$12,500 | \$126,250 |
| FR130 | \$27,000 | \$3,750 | \$31,000 | \$47,500 | \$13,500 | \$12,500 | \$135,250 |
| FR140 | \$59,220 | \$13,080 | \$103,000 | \$139,320 | \$54,900 | \$21,000 | \$390,520 |
| FR150 | \$43,800 | \$8,400 | \$84,000 | \$132,000 | \$35,520 | \$21,600 | \$325,320 |
| FR160 | \$18,000 | \$3,750 | \$31,000 | \$47,500 | \$13,500 | \$12,500 | \$126,250 |
| FR170 | \$18,000 | \$3,750 | \$31,000 | \$47,500 | \$13,500 | \$12,500 | \$126,250 |
| FR180 | \$21,000 | \$10,500 | \$20,000 | \$38,280 | \$16,300 | \$4,200 | \$110,280 |
| FR190 | \$15,600 | \$2,400 | \$36,000 | \$57,600 | \$8,500 | \$3,600 | \$123,700 |
| FR200 | \$1,800 | \$1,200 | \$4,500 | \$3,200 | \$2,400 | \$1,800 | \$14,900 |
| Totals | \$315,360 | \$71,940 | \$563,200 | \$768,600 | \$258,620 | \$132,500 | \$2,110,220 |

Table 9.1.j: Framing capital tooling costs

| Capital Tooling | | | | | |
|--|------------------|------------------|----------------------|--------------------|--------------------|
| Description | Mechanical Costs | Controller Costs | Purchased Items Cost | Construction Labor | Total |
| Safety fence, gates, curtains | \$25,200 | \$8,500 | \$114,000 | \$51,000 | \$198,700 |
| Robot simulation, programming, dress | \$102,600 | \$159,600 | \$115,500 | \$44,800 | \$422,500 |
| System layout and installation drawing | \$46,000 | | | | \$46,000 |
| Weld controllers | | | | | \$0 |
| Weld guns | | | | | \$0 |
| E/E changers | | | \$30,700 | \$3,360 | \$34,060 |
| Tip dresser/torch cleaner | | | | | \$0 |
| Air/water headers and valves | | | \$86,000 | \$103,000 | \$189,000 |
| Electronics and cables for operation | | \$135,000 | \$198,000 | \$64,250 | \$397,250 |
| Dispensing equipment | | | \$375,000 | \$15,500 | \$390,500 |
| Dispensing equipment - mastic | | | \$57,500 | \$3,200 | \$60,700 |
| Gravity conveyors | | | | | \$0 |
| Balconies and overhead structure | | | | | \$0 |
| Transfer system | | | | | \$0 |
| Welding robots (mig/braze) | | | | | \$0 |
| Materials handling robots | | | \$1,815,000 | \$69,300 | \$1,884,300 |
| Spir units | | | \$180,000 | \$2,400 | \$182,400 |
| Dispensing robots | | | | | \$0 |
| Seventh axis units | | | \$405,000 | \$25,500 | \$430,500 |
| Rivtac system | | | \$200,000 | \$2,400 | \$202,400 |
| Manipulators/load assists | \$21,600 | | \$26,400 | \$24,000 | \$72,000 |
| FSJ system | | | \$1,800,000 | \$16,200 | \$1,816,200 |
| DC nut runners B/UP style | | | \$112,000 | \$6,000 | \$118,000 |
| Vision system | | | \$300,000 | \$10,000 | \$310,000 |
| System lighting | | | \$29,000 | \$18,000 | \$47,000 |
| Inexable dunnage systems | | | \$120,000 | \$10,800 | \$130,800 |
| Stud insertion units | | | \$125,000 | \$16,000 | \$141,000 |
| Surface buffers | | | \$14,000 | \$8,000 | \$22,000 |
| Hi-lite lamps | | | \$28,050 | \$10,890 | \$38,940 |
| Totals | \$195,400 | \$303,100 | \$6,131,150 | \$504,600 | \$7,134,250 |

Table 9.1.k: Framing miscellaneous costs

| Miscellaneous Costs | | |
|-----------------------------------|-----------|---|
| Description | Cost | Remarks |
| Crating and loading | \$62,000 | |
| Freight | \$102,000 | |
| Training @ EBZ USA | | One, eight-hour training day included. More time quoted on request |
| Operation and maintenance manuals | \$33,000 | |
| 20-hour test run | \$21,000 | |
| 30-piece capability study | \$460,000 | Dependent on product availability. Includes dimensional assemblies and weld integrity testing |
| 300-piece test-part buy-off | \$202,000 | Dependent on product availability |
| 12-month warranty | Included | |
| Installation | \$626,000 | Complete system integration in customer plant using EBZ personnel |
| Installation supervision | \$59,000 | Supervision only using EBZ personnel |
| Startup assistance | \$155,000 | Includes two weeks with EBZ personnel, excluding expenses |

| | | |
|-------------------|--------------------|--|
| Design Processing | | Cycle charts, weld studies, and miscellaneous process activities |
| Total | \$1,720,000 | |

Table 9.1.l: Grand total framing investment

| | |
|-------------------------------|---------------------|
| Total tooling cost | \$2,110,220 |
| Total capital tooling cost | \$7,134,250 |
| Total miscellaneous item cost | \$1,720,000 |
| Grand total | \$10,964,470 |

Table 9.1.m: Tool shop tooling

| Tooling | | | | | | | |
|--------------------------------|------------------|------------------|----------------------|--------------------|-------------------------|------------|------------------|
| Description | Mechanical Costs | Controller Costs | Purchased Items Cost | Construction Labor | Controller Installation | Testing | Total |
| Perishable tooling quality | | | \$53,500 | | | | \$53,500 |
| Perishable tooling maintenance | | | \$115,000 | | | | \$115,000 |
| Totals | \$0 | \$0 | \$168,500 | \$0 | \$0 | \$0 | \$168,500 |

Table 9.1.n: Tool shop capital tooling

| Capital Tooling | | | | | |
|---------------------------------------|------------------|------------------|----------------------|--------------------|--------------------|
| Description | Mechanical Costs | Controller Costs | Purchased Items Cost | Construction Labor | Total |
| CMM DCC 20-foot dual arm | | | \$600,000 | | \$600,000 |
| CMM DCC 10-foot single arm | | | \$800,000 | | \$800,000 |
| System layout | \$3,500 | | | | \$3,500 |
| Miscellaneous quality-check equipment | | | \$45,000 | | \$45,000 |
| Boring mill | | | \$165,000 | | \$165,000 |
| Vertical bridgeport | | | \$40,000 | | \$40,000 |
| Surface grinder | | | \$15,000 | | \$15,000 |
| Welders | | | \$26,500 | | \$26,500 |
| Saws | | | \$15,000 | | \$15,000 |
| Drill/insertion press | | | \$15,000 | | \$15,000 |
| Tables | | | \$15,000 | | \$15,000 |
| Granite tables | | | \$15,000 | | \$15,000 |
| CNC milling center | | | \$105,000 | | \$105,000 |
| Miscellaneous | | | \$65,000 | | \$65,000 |
| Totals | \$3,500 | \$0 | \$1,921,500 | \$0 | \$1,925,000 |

Table 9.1.o: Tool shop miscellaneous tooling

| Miscellaneous Costs | | |
|-----------------------------------|----------|---|
| Description | Cost | Remarks |
| Crating and loading | | |
| Freight | \$45,000 | |
| Training @ EBZ USA | | One, eight-hour training day included. More time quoted on request |
| Operation and maintenance manuals | | |
| 20-hour test run | | |
| 30-piece capability study | | Dependent on product availability. Includes dimensional assemblies and weld integrity testing |
| 300-piece test-part buy-off | | Dependent on product availability |
| 12-month warranty | Included | |

| | | |
|--------------------------|------------------|---|
| Installation | \$280,000 | Complete system integration in customer plant using EBZ personnel |
| Installation supervision | \$15,000 | Supervision only using EBZ personnel |
| Startup assistance | | Includes two weeks with EBZ personnel, excluding expenses |
| Design Processing | | Cycle charts, weld studies, and miscellaneous process activities |
| Total | \$340,000 | |

Table 9.1.p: Grand total tool shop investment

| | |
|-------------------------------|--------------------|
| Total tooling cost | \$168,500 |
| Total capital tooling cost | \$1,925,000 |
| Total miscellaneous item cost | \$340,000 |
| Grand total | \$2,433,500 |

Table 9.1.q below gives the total capital investment required for the Phase 2 HD BIW plant.

Table 9.1.q: Total capital investment

| Category | Amount |
|----------------|---------------------|
| Sub-assembly | \$16,821,450 |
| Underbody | \$13,524,910 |
| Framing | \$10,964,470 |
| Conveyors | \$3,548,000 |
| Tool shop | \$2,433,500 |
| CMM | \$2,432,500 |
| Bins and racks | \$2,300,000 |
| Maintenance | \$743,870 |
| Total | \$52,768,700 |

Breaking the capital investment into per annum costs requires looking at the amortization schedule. All of the capital costs except the CMM and maintenance costs are amortized over five years while the CMM is amortized over seven and maintenance is per year. The CMM is amortized over seven years as it's not dependent on vehicle life cycle and can simply recalibrated for a different vehicle body. The plant must be retooled to produce a new body.

The amortized costs are shown in Table 9.1.r below per year and BIW. Year eight represents the cost of annual maintenance supplies only. Eight years however exceeds the typical vehicle life cycle.

Table 9.1.r: Per BIW and year amortized capital costs

| | Year 1 | Year 2 | Year 3 | Year 4 | Year 5 | Year 6 | Year 7 | Year 8 |
|----------------|--------------|--------------|--------------|--------------|--------------|-------------|-------------|-----------|
| Annual | \$11,009,836 | \$11,009,836 | \$11,009,837 | \$11,009,837 | \$11,009,838 | \$1,091,370 | \$1,091,370 | \$743,870 |
| Per BIW | \$183 | \$183 | \$183 | \$183 | \$183 | \$18 | \$18 | \$12 |

In addition to EBZ's recommended amortization schedule, two others were evaluated – straight three and five year amortizations. Like the EBZ recommended schedule, neither is depreciated. The major change by using a straight depreciation schedule is a constant

BIW cost over the amortization period. There is also a slight cost increase due to the condensed time frame. Both the three and five year amortized capital costs are shown below in Table 9.1.s.

Table 9.1.s: Capital costs amortized over three and five years

| | |
|---------------------------------|--------------|
| Capital cost total | \$52,768,700 |
| 3 year amortization annual cost | \$18,085,480 |
| 3 year amortization BIW cost | \$301 |
| 5 year amortization annual cost | \$11,148,836 |
| 5 year amortization BIW cost | \$186 |

9.2 Labor Costs

Labor costs for the Phase 2 HD BIW plant include the assembly, maintenance, and logistics workers that operate the factory on a daily basis to produce vehicles. These workers receive an hourly pay, with a 30-minute lunch break as well as benefits. Table 9.2.a below details the labor costs for the plant.

Table 9.2.a: Phase 2 HD BIW plant labor costs

| Assembly Workers | |
|-----------------------------------|--------------------|
| Number | \$24 |
| Wage | \$22 |
| Cost per shift | \$4,224 |
| Benefits (40% of wages) | \$1,690 |
| Total cost per shift | \$5,914 |
| Annual cost | \$2,956,800 |
| Maintenance Workers | |
| Number | \$11 |
| Wage | \$35 |
| Cost per shift | \$3,080 |
| Benefits (40% of wages) | \$1,232 |
| Total cost per shift | \$4,312 |
| Annual cost | \$2,156,000 |
| Logistics Workers | |
| Number | \$12 |
| Wage | \$18 |
| Cost per shift | \$1,728 |
| Benefits (60% of wages) | \$1,037 |
| Total cost per shift | \$2,765 |
| Annual cost | \$1,382,400 |
| Total labor cost per shift | \$12,990 |
| Annual labor cost | \$6,495,200 |

Table 4.5.6.2.b below shows the estimated cost increase per vehicle if the workers receive 3-percent annual raises. By the eighth year (the last year used in the financial analysis), this adds a total of \$17.30 to the cost of each vehicle.

Table 4.5.6.2.b: Phase 2 HD BIW estimated labor cost increases with 3% annual raises

Error! Not a valid link.

These wages are in line with current industry trends towards lower labor costs, with GM targeting a 40-percent reduction in labor costs by 2020. VW is already approaching these labor costs in the U.S. at its assembly plant in Chattanooga, Tennessee (<http://www.gminsidenews.com/forums/f12/how-small-car-helping-rewrite-labor-costs-u-s-plant-104321/>).

9.3 Utilities

Utilities are part of normal plant operation and include various water and electricity requirements, both for standard operations such as lighting and toilets as well as production equipment. Table 9.3.a below details the utility costs per assembly station.

Table 9.3.a: Utility costs by assembly station

| Station | High Pressure Flow Rate (dm3/s) | Low Pressure Flow Rate (dm3/s) | Cooling Water Flow Rate (dm3/s) | Welding Power Requirement (kW) | Indoor Power Requirement (kW) | Production Equipment Power Requirement (kW) | Inert Gas Consumption (dm3/s) |
|---------------------|---------------------------------|--------------------------------|---------------------------------|--------------------------------|-------------------------------|---|-------------------------------|
| SA05 | 0.00 | 7.91 | 0.24 | 0.00 | 0.00 | 1.10 | 0.68 |
| SA10 | 0.00 | 11.16 | 0.24 | 0.00 | 0.00 | 1.10 | 0.42 |
| SA15 | 0.00 | 15.27 | 0.48 | 0.00 | 0.00 | 3.30 | 0.00 |
| SA20 | 11.17 | 10.52 | 0.40 | 0.00 | 0.00 | 11.55 | 0.00 |
| SA25 | 0.00 | 0.29 | 0.48 | 0.00 | 0.00 | 0.55 | 0.00 |
| SA30 | 11.17 | 10.36 | 0.16 | 0.00 | 0.00 | 1.65 | 0.00 |
| SA35 | 11.17 | 2.30 | 0.40 | 0.00 | 0.00 | 12.10 | 0.00 |
| SA40 | 0.00 | 24.91 | 0.72 | 0.00 | 0.00 | 23.10 | 0.00 |
| SA45 | 11.17 | 6.90 | 0.40 | 0.00 | 0.00 | 12.10 | 0.00 |
| SA50 | 11.17 | 5.57 | 0.64 | 0.00 | 0.00 | 14.30 | 0.00 |
| SA55 | 0.00 | 6.28 | 0.00 | 0.00 | 0.00 | 0.00 | 0.00 |
| SA60 | 22.34 | 12.59 | 0.80 | 0.00 | 0.00 | 23.65 | 0.00 |
| SA65 | 11.17 | 8.12 | 0.40 | 0.00 | 0.00 | 14.30 | 0.00 |
| SA70-10 | 22.34 | 5.29 | 0.80 | 0.00 | 0.00 | 28.60 | 0.00 |
| SA70-20 | 22.34 | 15.11 | 0.56 | 0.00 | 0.00 | 28.60 | 0.00 |
| SA70-30 | 22.34 | 8.13 | 0.80 | 0.00 | 0.00 | 28.60 | 0.00 |
| SA75 | 22.34 | 15.11 | 0.56 | 0.00 | 0.00 | 28.60 | 0.00 |
| SA80 | 22.34 | 8.13 | 0.80 | 0.00 | 0.00 | 28.60 | 0.00 |
| SA85 | 22.34 | 9.25 | 0.56 | 0.00 | 0.00 | 24.20 | 0.00 |
| SA sub-total | 223.40 | 183.20 | 9.44 | 0.00 | 0.00 | 286.00 | 1.10 |
| SA cost | \$0.011 | \$0.009 | \$0.006 | \$0.000 | \$0.000 | \$0.060 | \$0.033 |

| | | | | | | | |
|------------------------------|----------------|----------------|----------------|----------------|----------------|-------------------------------|-----------------------|
| UB100 | 22.34 | 24.67 | 0.32 | 0.00 | 0.00 | 5.50 | 0.00 |
| UB110 | 44.68 | 5.67 | 1.60 | 0.00 | 0.00 | 20.35 | 0.00 |
| UB120 | 44.68 | 24.14 | 1.60 | 0.00 | 0.00 | 11.00 | 0.00 |
| UB130 | 0.00 | 5.66 | 0.00 | 0.00 | 0.00 | 4.40 | 0.00 |
| UB140 | 44.68 | 17.83 | 1.60 | 0.00 | 0.00 | 32.45 | 0.00 |
| UB150 | 0.00 | 6.23 | 0.00 | 0.00 | 0.00 | 8.80 | 0.00 |
| UB160 | 44.68 | 0.06 | 1.60 | 0.00 | 0.00 | 28.60 | 0.00 |
| UB170 | 0.00 | 4.01 | 0.96 | 0.00 | 0.00 | 8.80 | 0.00 |
| UB180 | 0.00 | 19.09 | 1.12 | 0.00 | 0.00 | 33.00 | 0.00 |
| UB190 | 0.00 | 0.76 | 1.28 | 0.00 | 0.00 | 10.45 | 0.00 |
| UB200 | 0.00 | 0.00 | 1.60 | 0.00 | 0.00 | 8.80 | 0.00 |
| UB210 | 0.00 | 5.63 | 0.96 | 0.00 | 0.00 | 48.40 | 0.00 |
| UB220 | 0.00 | 0.00 | 0.48 | 0.00 | 0.00 | 8.80 | 0.00 |
| UB sub-total | 201.06 | 113.75 | 13.12 | 0.00 | 0.00 | 229.35 | 0.00 |
| UB cost | \$0.010 | \$0.006 | \$0.007 | \$0.000 | \$0.000 | \$0.034 | \$0.000 |
| FR100 | 0.00 | 5.66 | 0.00 | 0.00 | 0.00 | 4.40 | 0.00 |
| FR110 | 0.00 | 43.90 | 2.56 | 0.00 | 0.00 | 45.10 | 0.00 |
| FR120 | 0.00 | 5.69 | 1.60 | 0.00 | 0.00 | 33.00 | 0.00 |
| FR130 | 0.00 | 17.08 | 0.48 | 0.00 | 0.00 | 44.00 | 0.00 |
| FR140 | 0.00 | 16.70 | 1.60 | 0.00 | 0.00 | 61.60 | 0.00 |
| FR150 | 0.00 | 16.33 | 1.28 | 0.00 | 0.00 | 28.05 | 0.00 |
| FR160 | 0.00 | 19.50 | 1.60 | 0.00 | 0.00 | 48.40 | 0.00 |
| FR170 | 0.00 | 4.55 | 0.96 | 0.00 | 0.00 | 8.80 | 0.00 |
| FR180 | 0.00 | 4.55 | 0.00 | 0.00 | 0.00 | 7.70 | 0.00 |
| FR190 | 0.00 | 4.55 | 0.00 | 0.00 | 0.00 | 7.70 | 0.00 |
| FR200 | 0.00 | 1.11 | 0.00 | 0.00 | 0.00 | 4.40 | 0.00 |
| FR210 | 0.00 | 4.55 | 0.00 | 0.00 | 0.00 | 11.55 | 0.00 |
| FR sub-total | 0.00 | 144.17 | 10.08 | 0.00 | 0.00 | 304.70 | 0.00 |
| FR cost | \$0.000 | \$0.006 | \$0.007 | \$0.000 | \$0.000 | \$0.055 | \$0.000 |
| Transport system | 0.00 | 0.00 | 0.00 | 0.00 | 0.00 | 41.80 | 0.00 |
| Transport system cost | \$0.000 | \$0.000 | \$0.000 | \$0.000 | \$0.000 | \$0.009 | \$0.000 |
| Grand total | 424.46 | 441.12 | 32.64 | 0.00 | 0.00 | 861.85 | 1.10 |
| Cost per second | \$0.02 | \$0.02 | \$0.02 | \$0.00 | \$0.00 | \$0.16 | \$0.03 |
| Cost per hour | \$75.60 | \$75.60 | \$72.00 | \$0.00 | \$0.00 | \$568.80 | \$118.80 |
| | | | | | | Utility costs per hour | \$910.80 |
| | | | | | | Utility costs per day | \$13,662.00 |
| | | | | | | Utility costs per year | \$3,415,500.00 |
| | | | | | | Utility costs per BIW | \$56.93 |

9.4 Investment Summary

This section presents a total overview of the necessary investment for the Phase 2 HD BIW plant. The costs are broken down annually and per BIW. Table 9.4.a below lists the annual and per BIW in white costs associated with the plant and manufacturing based on the first year of production only as capital costs vary per year, shown in Table 9.1.r.

Table 9.4.a: Investment summary per annum and BIW

| 60k per Year (First Year Only) | | |
|--------------------------------|--|---------------------|
| Category | Type | Amount |
| Capital | Sub-assembly capital tooling | \$9,957,980 |
| | Underbody capital tooling | \$9,477,520 |
| | Framing capital tooling | \$7,134,250 |
| | Sub-assembly tooling | \$4,557,970 |
| | Conveyors | \$3,548,000 |
| | Underbody tooling | \$2,728,090 |
| | Coordinate measuring machine | \$2,432,500 |
| | Miscellaneous sub-assembly | \$2,305,500 |
| | Bins and racks | \$2,300,000 |
| | Framing tooling | \$2,110,220 |
| | Tool shop capital tooling | \$1,925,000 |
| | Miscellaneous framing | \$1,720,000 |
| | Miscellaneous underbody | \$1,319,300 |
| | Maintenance | \$743,870 |
| | Miscellaneous tool shop | \$340,000 |
| | Tool shop tooling | \$168,500 |
| Capital sub-total | | \$52,768,700 |
| Amortized annual capital cost | | \$11,009,836 |
| Per BIW | | \$183 |
| Annual Labor | | |
| Annual Labor | Assembly workers | \$2,957,000 |
| | Maintenance workers | \$2,156,000 |
| | Logistics workers | \$1,382,500 |
| Annual labor sub-total | | \$6,495,500 |
| Labor per BIW | | \$108 |
| Annual Utilities | | |
| Annual Utilities | | \$2,937,600 |
| Utilities per BIW | | \$49 |
| Annual Interest | | |
| Annual Interest | | \$2,520,000 |
| Interest per BIW | | \$42 |
| Annual Freight | | |
| Annual Freight | | \$1,500,000 |
| Freight per BIW | | \$25 |
| Annual SG&A | | |
| Annual SG&A | Estimated as 7% of costs less freight and interest | \$1,431,006 |
| SG&A per BIW | | \$24 |
| Annual Total | | \$25,893,942 |
| Total per BIW | | \$432 |

Table 9.4.b below shows the costs to produce the parts needed per BIW broken up into various sub-categories such as variable, fixed, and direct costs per Intellicosting.

Table 9.4.b: Intellicosting BIW costs

| Cost Summary | |
|--------------|-------------------|
| Material | \$1,260.63 |
| Variable | \$135.63 |
| Fixed | \$138.62 |
| Direct | \$37.71 |
| Profit | \$125.81 |
| SG&A | \$78.63 |
| Freight | \$25.01 |
| Total | \$1,802.01 |

9.5 Sensitivity Analysis

A sensitivity analysis was conducted as part of the manufacturing study to determine the effect producing more vehicles – 100,000, 200,000, and 400,000 units per year – has on BIW cost. Increasing production to 100,000 units per year from 60,000 only requires the addition of a third shift with no changes to the plant. Increasing production to 100,000 units per year decreases the cost per BIW by 24 percent, around \$105. Table 9.5.a below details the effect of increasing BIW production by 40,000 units per year.

Table 9.5.a: Cost for producing 100,000 Phase 2 HD BIWs per year

| 100k per Year (First Year Only) | | |
|---------------------------------|------------------------------|--------------|
| Category | Type | Amount |
| Capital | Sub-assembly capital tooling | \$9,957,980 |
| | Underbody capital tooling | \$9,477,520 |
| | Framing capital tooling | \$7,134,250 |
| | Sub-assembly tooling | \$4,557,970 |
| | Conveyors | \$3,548,000 |
| | Underbody tooling | \$2,728,090 |
| | Coordinate measuring machine | \$2,432,500 |
| | Miscellaneous sub-assembly | \$2,305,500 |
| | Bins and racks | \$2,300,000 |
| | Framing tooling | \$2,110,220 |
| | Tool shop capital tooling | \$1,925,000 |
| | Miscellaneous framing | \$1,720,000 |
| | Miscellaneous underbody | \$1,319,300 |
| | Maintenance | \$743,870 |
| | Miscellaneous tool shop | \$340,000 |
| | Tool shop tooling | \$168,500 |
| Capital sub-total | | \$52,768,700 |
| Amortized annual capital cost | | \$11,009,836 |
| Per BIW | | \$110 |

| | | |
|------------------------|--|---------------------|
| | | |
| Annual Labor | Assembly workers | \$4,435,200 |
| | Maintenance workers | \$3,234,000 |
| | Logistics workers | \$2,073,600 |
| Annual labor sub-total | | \$9,742,800 |
| Labor per BIW | | \$97 |
| | | |
| Annual Utilities | | \$5,123,250 |
| Utilities per BIW | | \$51 |
| | | |
| Annual Interest | | \$2,520,000 |
| Interest per BIW | | \$25 |
| | | |
| Annual Freight | | \$2,500,000 |
| Freight per BIW | | \$25 |
| | | |
| Annual SG&A | Estimated as 7% of costs less freight and interest | \$1,811,312 |
| SG&A per BIW | | \$18 |
| | | |
| Annual Total | | \$32,707,198 |
| Total per BIW | | \$327 |
| Cost decrease | | 24% |

Table 9.5.b below compares the annual capital, annual total manufacturing, and per BIW manufacturing costs for production of 60,000 and 100,000 BIWs per year. This includes the amortized capital costs and affected SG&A costs. Year eight represents only paying the annual maintenance capital costs.

Table 9.5.b: Manufacturing cost comparison, 60,000 vs. 100,000 BIWs

| Production | Category | Year 1 | Year 2 | Year 3 | Year 4 | Year 5 | Year 6 | Year 7 | Year 8 |
|------------|----------------------------|----------------|----------------|----------------|----------------|----------------|----------------|----------------|----------------|
| 60k | Capital costs (mils) | \$11.01 | \$11.01 | \$11.01 | \$11.01 | \$11.01 | \$1.09 | \$1.09 | \$0.74 |
| | Labor (mils) | \$6.50 | \$6.50 | \$6.50 | \$6.50 | \$6.50 | \$6.50 | \$6.50 | \$6.50 |
| | Utilities (mils) | \$2.94 | \$2.94 | \$2.94 | \$2.94 | \$2.94 | \$2.94 | \$2.94 | \$2.94 |
| | Interest (mils) | \$2.52 | \$2.52 | \$2.52 | \$2.52 | \$2.52 | \$2.52 | \$2.52 | \$2.52 |
| | Freight (mils) | \$1.50 | \$1.50 | \$1.50 | \$1.50 | \$1.50 | \$1.50 | \$1.50 | \$1.50 |
| | SG&A (mils) | \$1.43 | \$1.43 | \$1.43 | \$1.43 | \$1.43 | \$0.74 | \$0.74 | \$0.71 |
| | Annual Total (mils) | \$25.89 | \$25.89 | \$25.89 | \$25.89 | \$25.89 | \$15.28 | \$15.28 | \$14.91 |
| | BIW Total | \$432 | \$432 | \$432 | \$432 | \$432 | \$255 | \$255 | \$248 |
| 100k | Capital costs (mils) | \$11.01 | \$11.01 | \$11.01 | \$11.01 | \$11.01 | \$1.09 | \$1.09 | \$0.74 |
| | Labor (mils) | \$9.74 | \$9.74 | \$9.74 | \$9.74 | \$9.74 | \$9.74 | \$9.74 | \$9.74 |
| | Utilities (mils) | \$5.12 | \$5.12 | \$5.12 | \$5.12 | \$5.12 | \$5.12 | \$5.12 | \$5.12 |
| | Interest (mils) | \$2.52 | \$2.52 | \$2.52 | \$2.52 | \$2.52 | \$2.52 | \$2.52 | \$2.52 |
| | Freight (mils) | \$2.50 | \$2.50 | \$2.50 | \$2.50 | \$2.50 | \$2.50 | \$2.50 | \$2.50 |
| | SG&A (mils) | \$1.81 | \$1.81 | \$1.81 | \$1.81 | \$1.81 | \$1.12 | \$1.12 | \$1.09 |
| | Annual Total (mils) | \$32.71 | \$32.71 | \$32.71 | \$32.71 | \$32.71 | \$22.09 | \$22.09 | \$21.72 |



LOTUS ARB LWV PROGRAM

| | | | | | | | | |
|----------------------|--------------|--------------|--------------|--------------|--------------|--------------|--------------|--------------|
| BIW Total | \$327 | \$327 | \$327 | \$327 | \$327 | \$221 | \$221 | \$217 |
| Cost Decrease | 24% | 24% | 24% | 24% | 24% | 13% | 13% | 12% |

9.6 Tooling Costs

There are costs associated with purchasing the tooling to produce the individual parts used in the manufacturing process. Table 9.6.a below details these tooling costs, which total approximately \$28.1 million for the Phase 2 HD BIW. Tooling for a similar Toyota Venza BIW costs around \$70 million according to Intellicosting (estimate based on low volume tooling to support 60,000 units/yr.).

Table 9.6.a: Phase 2 HD BIW tooling costs

| Part Number | Part Name | Process | Tool Type | Tool Cost | Tool Count | Inspection Cost | Fixture Count |
|--------------------------------|--|----------|--|-----------|------------|-----------------|---------------|
| Front End | | | | | | | |
| 7305-2400-001 | Small crossmember reinforcement | Stamping | Complete progressive die | \$104,559 | 1 | \$1,500 | 1 |
| 7305-2400-002 | Large crossmember reinforcement | Stamping | Complete progressive die | \$114,797 | 1 | \$1,700 | 1 |
| Bodyside Outer Assembly | | | | | | | |
| 7306-2300-185 | Left, outer bodyside panel | Stamping | Transfer dies | | | \$77,900 | 1 |
| | | | Rough blank (through) | \$78,788 | 1 | | |
| | | | Draw (toggle) | \$221,338 | 1 | | |
| | | | Trim and developed trim | \$179,543 | 1 | | |
| | | | Trim and developed trim | \$170,360 | 1 | | |
| | | | Finish form, flange, and restrike | \$221,641 | 1 | | |
| | | | Cam finish form, finish trim, flange, and restrike | \$323,575 | 1 | | |
| | | | End of arm tooling | \$20,000 | | | |
| 7306-2300-186 | Right, outer bodyside panel | Stamping | Transfer dies | | | \$77,900 | 1 |
| | | | Rough blank (through) | \$78,788 | 1 | | |
| | | | Draw (toggle) | \$221,338 | 1 | | |
| | | | Trim and developed trim | \$179,543 | 1 | | |
| | | | Trim and developed trim | \$170,360 | 1 | | |
| | | | Finish form, flange, and restrike | \$221,641 | 1 | | |
| | | | Cam finish form, finish trim, flange, and restrike | \$323,575 | 1 | | |
| | | | End of arm tooling | \$20,000 | | | |
| 7306-2300-187 | Lower, left rear quarter closeout panel | Stamping | Line dies on common shoe (hand transfer) | | | \$11,500 | 1 |
| 7306-2300-188 | Lower, right rear quarter closeout panel | | Form (double attached) | \$48,094 | 1 | \$11,500 | 1 |
| | | | Trim and developed trim | \$54,449 | 1 | | |
| | | | Finish form and flange (double pad) | \$64,348 | 1 | | |
| | | | Finish trim and separate | \$42,106 | 1 | | |
| | | | Flange and restrike (double pad and double unattached) | \$62,632 | 1 | | |



LOTUS ARB LWV PROGRAM

| | | | | | | | |
|---------------|----------------------------------|----------|--|-----------|---|----------|---|
| | | | Common Shoe | \$19,984 | | | |
| 7306-2300-189 | Left flange to body | Stamping | Complete progressive die (2 out, 1 left and 1 right) | \$195,951 | 1 | \$18,000 | 1 |
| 7306-2300-190 | Right flange to body | | | | | \$18,000 | 1 |
| 7306-2300-191 | Left tail lamp closeout panel | Stamping | Complete progressive die (2 out, 1 left and 1 right) | \$80,703 | 1 | | |
| 7306-2300-192 | Right tail lamp closeout panel | | | | | | |
| 7306-2300-XXX | Left, upper rear closeout panel | Stamping | Progressive blank die (2 out, 1 left and 1 right) | \$92,887 | 1 | \$3,500 | 1 |
| 7306-2300-XXX | Right, upper rear closeout panel | | Form and flange (double pad) | \$43,265 | 1 | \$3,500 | 1 |
| | | | Restrike and cam flange | \$36,986 | 1 | | |
| | | | Common shoe | \$10,378 | | | |
| Roof | | | | | | | |
| 7306-2200-109 | Roof panel | Stamping | Lines with robotic transfer | | | \$77,500 | 1 |
| | | | Draw | \$173,807 | 1 | | |
| | | | Trim and developed trim | \$198,072 | 1 | | |
| | | | Finish form, flange, and restrike | \$208,060 | 1 | | |
| | | | End of arm tooling | \$9,000 | | | |
| 7306-2100-101 | Front header (bow 1) | Stamping | Coil fed transfer die | | | \$14,800 | 1 |
| | | | Cutoff and draw | \$57,820 | 1 | | |
| | | | Trim | \$64,302 | 1 | | |
| | | | Finish form and flange | \$65,305 | 1 | | |
| | | | Finish trim | \$60,365 | 1 | | |
| | | | Restrike | \$64,736 | 1 | | |
| | | | Master shoes | \$47,361 | | | |
| | | | End of arm tooling | \$12,500 | | | |
| 7306-2100-103 | Center header (bow 2) | Stamping | Complete progressive die | \$127,928 | 1 | \$6,500 | 1 |
| 7307-2100-104 | Rear header (bow 3) | Stamping | Transfer dies | | | \$27,500 | 1 |
| | | | Draw | \$52,969 | 1 | | |
| | | | Form | \$51,038 | 1 | | |
| | | | Form | \$51,038 | 1 | | |
| | | | Trim and pierce | \$70,184 | 1 | | |
| | | | Finish form, flange, and restrike | \$55,997 | 1 | | |
| | | | Common shoes | \$40,773 | | | |
| | | | End of arm tooling | \$15,000 | | | |
| 7306-2000-215 | Left, rear roof side rail inner | Stamping | Transfer dies | | | \$19,400 | 1 |
| 7306-2000-216 | Right, rear roof side rail inner | | Draw (double attached) | \$77,254 | 1 | \$19,400 | 1 |
| | | | Trim, developed trim, and partial separate | \$101,937 | 1 | | |
| | | | Finish form, flange, and restrike | \$115,242 | 1 | | |
| | | | Finish trim and separate | \$70,324 | 1 | | |



LOTUS ARB LWV PROGRAM

| | | | | | | | |
|--------------------------|-----------------------------------|----------|--|-----------|---|----------|---|
| | | | Common shoes | \$59,758 | | | |
| | | | End of arm tooling | \$12,800 | | | |
| 7306-2000-171 | Left, front roof side rail inner | Stamping | Transfer dies | | | \$20,500 | 1 |
| 7306-2000-172 | Right, front roof side rail inner | | Rough developed blank | \$75,651 | 1 | \$20,500 | 1 |
| | | | Form (double attached) | \$86,347 | 1 | | |
| | | | Trim, developed trim, and partial separate | \$114,175 | 1 | | |
| | | | Finish form, flange, and restrike | \$129,433 | 1 | | |
| | | | Finish trim and separate | \$97,949 | 1 | | |
| | | | Master shoes | \$40,671 | | | |
| | | | End of arm tooling | \$16,000 | | | |
| 7305-1900-159 | Left shotgun closeout | Stamping | Complete progressive die | \$37,190 | 1 | \$600 | 1 |
| 7305-1900-160 | Right shotgun closeout | | | | | \$600 | 1 |
| D-pillar Assembly | | | | | | | |
| 7307-2110-179 | Left liftgate reinforcement | Stamping | Line dies on common shoe (hand transfer) | | | \$6,800 | 1 |
| 7307-2120-180 | Right liftgate reinforcement | | Form (double attached) | \$52,567 | 1 | \$6,800 | 1 |
| | | | Trim and developed trim | \$64,216 | 1 | | |
| | | | Trim and developed trim | \$63,082 | 1 | | |
| | | | Finish form and flange (double pad) | \$73,414 | 1 | | |
| | | | Restrike and separate | \$69,770 | 1 | | |
| | | | Common shoe | \$27,234 | | | |
| 7307-2110-105 | Left D-pillar inner | Stamping | Transfer dies | | | \$18,900 | 1 |
| 7307-2120-106 | Right D-pillar inner | | Rough blank | \$56,788 | 1 | \$18,900 | 1 |
| | | | Draw (double attached) | \$81,398 | 1 | | |
| | | | Redraw | \$82,579 | 1 | | |
| | | | Trim and developed trim | \$91,616 | 1 | | |
| | | | Trim, developed trim, and separate | \$85,274 | 1 | | |
| | | | Finish form and restrike (double unattached) | \$93,307 | 1 | | |
| | | | Master shoes | \$62,202 | | | |
| | | | End of arm tooling | | | | |
| 7307-2110-177 | Left quarter panel inner | Stamping | Transfer dies | | | \$6,200 | |
| 7307-2120-178 | Right quarter panel inner | | Draw (double attached) | \$72,014 | 1 | \$6,200 | |
| | | | Trim and developed trim | \$73,368 | 1 | | |
| | | | Trim and developed trim | \$69,069 | 1 | | |
| | | | Finish form, flange, and restrike (double pad) | \$75,455 | 1 | | |
| | | | Cam trim, trim, and separate | \$81,170 | 1 | | |
| | | | Master shoes | \$49,982 | | | |
| | | | End of arm tooling | \$10,500 | | | |
| A-pillar Assembly | | | | | | | |



LOTUS ARB LWV PROGRAM

| | | | | | | | |
|-------------------------------|--|----------|---|-----------|---|----------|---|
| 7305-1930-169 | Left shotgun outer panel | Stamping | Transfer dies | | | \$22,500 | 1 |
| 7305-1940-170 | Right shotgun outer panel | | Rough blank die (2 out, 1 left and 1 right) | \$127,161 | 1 | \$22,500 | 1 |
| | | | Form | \$77,416 | 1 | | |
| | | | Finish form and flange | \$112,533 | 1 | | |
| | | | Trim | \$124,796 | 1 | | |
| | | | Flange and restrike | \$74,492 | 1 | | |
| | | | Master shoes | \$45,023 | | | |
| | | | End of arm tooling | \$14,400 | | | |
| 7305-1930-187 | Left, lower A-pillar outer | Stamping | Line dies with robotic transfer | | | \$16,000 | 1 |
| 7305-1940-188 | Right, lower A-pillar outer | | Blank (flip/flop left/right) | \$102,114 | 1 | \$16,000 | 1 |
| | | | Form (double unattached) | \$115,352 | 1 | | |
| | | | Trim and developed trim | \$105,079 | 1 | | |
| | | | Trim and developed trim | \$118,609 | 1 | | |
| | | | Finish form and flange | \$80,009 | 1 | | |
| | | | Restrike | \$131,158 | 1 | | |
| | | | End of arm tooling | \$7,500 | | | |
| 7305-1930-171 | Left, A-pillar, upper hinge reinforcement | Stamping | Complete progressive die | \$13,902 | 1 | \$350 | 1 |
| 7305-1940-184 | Right, A-pillar, upper hinge reinforcement | | | | | \$350 | 1 |
| 7305-1930-173 | Left, A-pillar, lower hinge reinforcement | Stamping | Complete progressive die | \$13,596 | 1 | \$350 | 1 |
| 7305-1940-186 | Right, A-pillar, lower hinge reinforcement | | | | | \$350 | 1 |
| 7305-1500-227 | Left, lower, A-pillar reinforcement | Stamping | Complete progressive die | \$54,462 | 1 | \$900 | 1 |
| 7305-1500-228 | Right, lower, A-pillar reinforcement | | | | | | |
| 7305-1400-153 | Left, lower A-pillar inner | Stamping | Line dies on common shoe (hand transfer) | | | \$4,400 | 1 |
| 7305-1400-154 | Right, lower A-pillar inner | | Draw | \$55,162 | 1 | \$4,400 | 1 |
| | | | Restrike | \$58,268 | 1 | | |
| | | | Trim and partial separate | \$51,334 | 1 | | |
| | | | Cam trim, trim, and separate | \$66,797 | 1 | | |
| | | | Common shoe | \$18,367 | | | |
| 7305-1300-155 | Left, upper A-pillar inner | Stamping | Line dies on common shoe (hand transfer) | | | \$28,000 | 1 |
| 7305-1300-156 | Right, upper A-pillar inner | | Progressive developed blank (double attached) | \$139,832 | 1 | \$28,000 | 1 |
| | | | Form and flange | \$67,679 | 1 | | |
| | | | Flange and restrike (double pad) | \$68,126 | 1 | | |
| | | | Extrude and separate | \$55,145 | 1 | | |
| | | | Common shoe | \$16,962 | | | |
| Door Aperture Assembly | | | | | | | |

| | | | | | | | |
|---------------|---------------------------------------|----------|--|-----------|---|----------|---|
| 7306-1910-189 | Left, A-pillar outer upper | Stamping | Transfer dies | | | \$19,500 | 1 |
| 7306-1920-190 | Right, A-pillar outer upper | | Draw (double attached) | \$105,668 | 1 | \$19,500 | 1 |
| | | | Trim, developed trim, and partial separate | \$128,641 | 1 | | |
| | | | Finish form, flange, and restrike | \$135,645 | 1 | | |
| | | | Finish trim and separate | \$97,420 | 1 | | |
| | | | Master shoes | \$40,392 | | | |
| | | | End of arm tooling | \$12,000 | | | |
| 7306-1910-191 | Left, roof side rail outer | Stamping | Transfer dies | | | \$16,000 | 1 |
| 7306-1920-192 | Right, roof side rail outer | | Draw (double attached) | \$79,668 | 1 | \$16,000 | 1 |
| | | | Trim, developed trim, and partial separate | \$105,077 | 1 | | |
| | | | Finish form, flange, and restrike | \$105,767 | 1 | | |
| | | | Finish trim and separate | \$89,247 | 1 | | |
| | | | Master shoes | \$41,042 | | | |
| | | | End of arm tooling | \$16,000 | | | |
| 7306-1910-193 | Left, C-pillar striker reinforcement | Stamping | Complete progressive die (2 out, 1 left and 1 right) | \$34,332 | 1 | \$650 | 1 |
| 7306-1920-194 | Right, C-pillar striker reinforcement | | | | | \$650 | 1 |
| 7306-1910-195 | Left C-pillar outer | Stamping | Line dies with robotic transfer | | | \$39,000 | 1 |
| 7306-1920-196 | Right C-pillar outer | | Rough blank (double attached) | \$93,644 | 1 | \$39,000 | 1 |
| | | | Draw (double attached) | \$151,092 | 1 | | |
| | | | Trim and developed trim | \$167,760 | 1 | | |
| | | | Trim and developed trim | \$165,870 | 1 | | |
| | | | Finish form, flange, and restrike (double pad) | \$205,755 | 1 | | |
| | | | Separate and cam set flanges | \$144,189 | 1 | | |
| | | | End of arm tooling | \$15,000 | | | |
| 7306-1913-001 | Left, lower B-pillar outer | Stamping | Line dies with robotic transfer | | | \$32,500 | 1 |
| 7306-1924-002 | Right, lower B-pillar outer | | Rough blank (flip/flop left/right) | \$101,111 | 1 | \$32,500 | 1 |
| | | | Draw (double unattached) | \$149,138 | 1 | | |
| | | | Redraw | \$152,991 | 1 | | |
| | | | Trim and pierce | \$174,868 | 1 | | |
| | | | Trim and pierce | \$167,712 | 1 | | |
| | | | Finish form, flange, and restrike | \$179,334 | 1 | | |
| | | | End of arm tooling | \$15,000 | | | |
| 7306-1913-003 | Left, upper B-pillar outer | Stamping | Transfer dies | | | \$5,900 | 1 |
| 7306-1924-004 | Right, upper B-pillar outer | | Draw (double attached) | \$46,469 | 1 | \$5,900 | |
| | | | Rough trim and developed trim | \$50,711 | 1 | | |

| | | | | | | | |
|--------------------------------|---|----------------|--|-----------|---|----------|---|
| | | | Rough trim and developed trim | \$48,596 | 1 | | |
| | | | Finish form, flange, and restrike | \$55,535 | 1 | | |
| | | | Cam trim, trim, and separate | \$75,051 | 1 | | |
| | | | Master shoes | \$29,621 | | | |
| | | | End of arm tooling | \$12,000 | | | |
| 7306-1913-005 | Left, upper, B-pillar inner reinforcement | Stamping | Complete progressive die (2 out, 1 left and 1 right) | \$72,875 | 1 | \$1,250 | 1 |
| 7306-1924-006 | Right, upper, B-pillar inner reinforcement | | | | | \$1,250 | 1 |
| 7306-1913-007 | Left, middle, B-pillar inner reinforcement | Stamping | Complete progressive die (2 out, 1 left and 1 right) | \$32,508 | 1 | \$600 | 1 |
| 7306-1924-008 | Right, middle, B-pillar inner reinforcement | | | | | \$600 | 1 |
| 7306-1913-009 | Left, lower, B-pillar inner reinforcement | Stamping | Complete progressive die (2 out, 1 left and 1 right) | \$81,191 | 1 | \$950 | 1 |
| 7306-1924-010 | Right, lower, B-pillar inner reinforcement | | | | | \$950 | 1 |
| 7306-1915-011 | Left, lower B-pillar inner | Stamping | Line dies with robotic transfer | | | \$15,500 | 1 |
| 7306-1926-012 | Right, lower B-pillar inner | | Rough blank (flip/flop left/right) | \$891,730 | 1 | \$15,500 | 1 |
| | | | Draw (double unattached) | \$85,677 | 1 | | |
| | | | Trim and pierce | \$119,560 | 1 | | |
| | | | Trim and pierce | \$119,560 | 1 | | |
| | | | Finish form, extrude, and restrike (double pad) | \$99,233 | 1 | | |
| | | | End of arm tooling | \$16,000 | | | |
| 7306-1915-001 | Left/right B-pillar beltline reinforcement | Stamping | Complete progressive die | \$16,934 | 1 | \$500 | 1 |
| 7306-1915-013 | Left, upper B-pillar inner | Stamping | Complete progressive die (2 out, 1 left and 1 right) | \$97,237 | 1 | \$3,300 | 1 |
| 7306-1926-014 | Right, upper B-pillar inner | | | | | \$3,300 | 1 |
| Dash and Cowl Structure | | | | | | | |
| 7305-1800-145 | Upper cowl panel | Cast magnesium | Casting mold | \$141,000 | 1 | \$23,400 | 1 |
| | | | Trim die | \$60,561 | 1 | | |
| 7305-1700-147 | Cowl panel support | Stamping | Transfer dies | | | \$18,500 | 1 |
| | | | Draw | \$74,731 | 1 | | |
| | | | Trim and developed trim | \$92,078 | 1 | | |
| | | | Trim, developed trim, and cam trim | \$112,671 | 1 | | |
| | | | Finish form, flange, and restrike | \$95,243 | 1 | | |
| | | | Common shoes | \$20,631 | | | |
| | | | End of arm tooling | \$10,000 | | | |
| 7305-1600-149 | Dash panel reinforcement | Cast magnesium | Casting mold | \$216,000 | 1 | \$31,600 | 1 |

| | | | | | | | |
|---------------|--|----------------|--|-----------|---|----------|---|
| | | | Trim die | \$132,513 | 1 | | |
| 7307-1600-183 | Left, rear wheelhouse outer panel | Cast magnesium | Casting mold | \$250,000 | 1 | \$43,800 | 1 |
| | | | Trim die | \$142,164 | 1 | | |
| 7307-1600-184 | Right, rear wheelhouse outer panel | Cast magnesium | Casting mold | \$240,000 | 1 | \$41,400 | 1 |
| | | | Trim die | \$138,966 | 1 | | |
| 7307-1600-213 | Left, rear closeout panel | Stamping | Complete progressive die (2 out, 1 left and 1 right) | \$192,307 | 1 | \$9,600 | 1 |
| 7307-1600-214 | Right, rear closeout panel | | | | | \$9,600 | 1 |
| 7305-1500-157 | Left, shotgun panel inner | Stamping | Transfer dies | | | \$28,500 | 1 |
| 7305-1500-158 | Right, shotgun panel inner | | Rough blank die (2 out, 1 left and 1 right) | \$133,440 | 1 | \$28,500 | 1 |
| | | | Form | \$87,170 | 1 | | |
| | | | Finish form and flange | \$117,563 | 1 | | |
| | | | Trim | \$132,094 | 1 | | |
| | | | Flange and restrike | \$77,572 | 1 | | |
| | | | Master shoes | \$48,895 | | | |
| | | | End of arm tooling | \$14,400 | | | |
| 7305-1500-197 | Left, upper A-pillar reinforcement | Stamping | Complete progressive die (2 out, 1 left and 1 right) | \$137,042 | 1 | \$2,250 | 1 |
| 7305-1500-198 | Right, upper A-pillar reinforcement | | | | | \$2,250 | 1 |
| 7305-1530-221 | Left, dash transmission reinforcement | Stamping | Line dies (hand transfer) | | | \$21,500 | 1 |
| 7305-1530-222 | Right, dash transmission reinforcement | | Draw (double unattached) | \$93,191 | 1 | \$21,500 | 1 |
| | | | Second draw | \$96,656 | 1 | | |
| | | | Rough trim and developed trim | \$88,494 | 1 | | |
| | | | Developed trim and cam developed trim | \$87,500 | 1 | | |
| | | | Form and flange | \$88,188 | 1 | | |
| | | | Form and flange | \$82,126 | 1 | | |
| | | | Finish trim, pierce, and cam pierce | \$93,594 | 1 | | |
| | | | Cam flange and restrike | \$81,087 | 1 | | |
| 7305-1530-223 | Left, dash transmission insert | Stamping | Complete progressive die (2 out, 1 left and 1 right) | \$62,424 | 1 | \$950 | 1 |
| 7305-1520-224 | Right, dash transmission insert | | | | | \$950 | 1 |
| 7305-1400-143 | Upper dash panel | Cast magnesium | Casting mold | \$206,000 | 1 | \$52,700 | 1 |
| | | | Trim die | \$129,768 | 1 | | |

| | | | | | | | |
|-----------------|---------------------------------------|----------------|--|-----------|---|----------|---|
| 7305-1400-144 | Left lower dash panel | Cast magnesium | Casting mold | \$317,000 | 1 | \$36,000 | 1 |
| 7305-1400-145 | Right lower dash panel | | Trim die | \$230,467 | 1 | \$36,000 | 1 |
| Rear End | | | | | | | |
| 7307-1510-111 | Rear end outer panel | Stamping | Line dies with robotic transfer | | | \$43,500 | 1 |
| | | | Draw | \$74,912 | 1 | | |
| | | | Trim and developed trim | \$81,087 | 1 | | |
| | | | Trim and developed trim | \$81,016 | 1 | | |
| | | | Finish form and flange | \$83,914 | 1 | | |
| | | | Finish form, flange, and restrike | \$85,112 | 1 | | |
| | | | Finish trim and pierce | \$82,672 | 1 | | |
| | | | End of arm tooling | \$18,000 | | | |
| 7307-1510-117 | Rear end inner panel | Stamping | Line dies with robotic transfer | | | \$39,500 | 1 |
| | | | Draw | \$84,640 | 1 | | |
| | | | Rough trim and developed trim | \$92,852 | 1 | | |
| | | | Redraw | \$80,037 | 1 | | |
| | | | Developed trim | \$89,698 | 1 | | |
| | | | Developed trim and pierce | \$91,062 | 1 | | |
| | | | Finish form, flange, and restrike (double pad) | \$95,070 | 1 | | |
| | | | End of arm tooling | \$18,000 | | | |
| 7307-1400-119 | Rear compartment crossmember | Extrude | Extrusion tooling | \$49,416 | 2 | \$12,000 | 1 |
| | | | Trim jig | \$3,115 | 1 | | |
| 7307-1410-120 | Extrusion hangar bracket | Extrude | Extrusion tooling | \$49,986 | 2 | \$1,250 | 1 |
| | | | Trim jig | \$2,041 | 1 | | |
| 7307-1400-163 | Left, rear wheelhouse inner panel | Stamping | Line dies with robotic transfer | | | \$38,500 | 1 |
| 7307-1400-164 | Right, rear wheelhouse inner panel | | Draw (double attached) | \$146,206 | 1 | \$38,500 | 1 |
| | | | Trim and developed trim | \$163,555 | 1 | | |
| | | | Trim and developed trim | \$163,555 | 1 | | |
| | | | Finish form, flange, and restrike (double pad) | \$238,243 | 1 | | |
| | | | Finish trim and separate | \$117,380 | 1 | | |
| | | | End of arm tooling | \$15,000 | | | |
| 7307-1500-167 | Left, rear shock tower reinforcement | Stamping | Line dies on common shoes (hand transfer) | | | \$3,100 | 1 |
| 7307-1500-168 | Right, rear shock tower reinforcement | | Draw (double attached) | \$38,164 | 1 | \$3,100 | 1 |
| | | | Trim and rough trim | \$44,667 | 1 | | |
| | | | Developed trim | \$39,082 | 1 | | |
| | | | Cam developed trim | \$56,093 | 1 | | |
| | | | Finish form and flange | \$42,219 | 1 | | |
| | | | Aerial cam flange | \$64,149 | 1 | | |
| | | | Separate and restrike | \$42,620 | 1 | | |

| | | | | | | | |
|-------------------------|--|----------------|------------------------------------|-----------|---|----------|---|
| | | | Common shoes | \$28,685 | | | |
| 7305-1300-165 | Left, rear shock tower | Die cast | Casting mold | \$126,000 | 1 | \$26,000 | 1 |
| | | | Trim die | \$75,977 | 1 | | |
| 7305-1300-166 | Right, rear shock tower | Die cast | Casting mold | \$132,000 | 1 | \$26,000 | 1 |
| | | | Trim die | \$75,977 | 1 | | |
| Front Wheelhouse | | | | | | | |
| 7305-1310-151 | Left front shock tower | Die cast | Casting mold | \$119,000 | 1 | \$27,500 | 1 |
| | | | Trim die | \$79,812 | 1 | | |
| 7305-1320-152 | Right front shock tower | Die cast | Casting mold | \$125,000 | 1 | \$27,500 | 1 |
| | | | Trim die | \$79,812 | 1 | | |
| 7305-1310-161 | Left front wheelhouse panel | Cast magnesium | Casting mold | \$141,000 | 1 | \$21,900 | 1 |
| | | | Trim die | \$80,095 | 1 | | |
| 7305-1320-162 | Right front wheelhouse panel | Cast magnesium | Casting mold | \$148,000 | 1 | \$21,900 | 1 |
| | | | Trim die | \$80,095 | 1 | | |
| Rear Seat | | | | | | | |
| 7306-1200-113 | Rear seat floor panel | Stamping | Line dies with robotic transfer | | | \$33,800 | 1 |
| | | | Draw | \$93,535 | 1 | | |
| | | | Trim | \$114,717 | 1 | | |
| | | | Finish form and restrike | \$77,468 | 1 | | |
| | | | End of arm tooling | \$9,000 | | | |
| 7306-1200-111 | Rear seatbelt anchorage plate | Stamping | Complete progressive die | \$26,206 | 1 | \$650 | 1 |
| 7307-1200-217 | Left, rear, outer frame rail transition | Die cast | Casting mold | \$192,000 | 1 | \$28,500 | 1 |
| | | | Trim die | \$116,537 | 1 | | |
| 7307-1200-218 | Right, rear, outer frame rail transition | Die cast | Casting mold | \$199,000 | 1 | \$28,500 | 1 |
| | | | Trim die | \$116,537 | 1 | | |
| 7306-1110-101 | Center rear seat riser | Stamping | Complete progressive die | \$216,500 | 1 | \$29,800 | 1 |
| 7306-1110-103 | Left, rear seat floor reinforcement | Stamping | Complete progressive die | \$58,424 | 1 | \$2,600 | 1 |
| 7306-1000-175 | Left rear seat riser | Stamping | Line dies with robotic transfer | | | \$21,500 | 1 |
| 7306-1000-176 | Right rear seat riser | | Rough blank (flip/flop left/right) | \$53,598 | 1 | \$21,500 | 1 |
| | | | Form (double unattached) | \$61,333 | 1 | | |
| | | | Trim and developed trim | \$80,561 | 1 | | |
| | | | Trim and developed trim | \$80,561 | 1 | | |
| | | | Finish form and flange | \$97,654 | 1 | | |



LOTUS ARB LWV PROGRAM

| | | | | | | | |
|--------------------|---|----------|----------------------------------|-----------|---|----------|---|
| | | | Restrike | \$91,442 | 1 | | |
| | | | End of arm tooling | \$16,000 | | | |
| Frame Rails | | | | | | | |
| 7307-1000-139 | Right/left rear frame rail | Extrude | Extrusion tooling | \$46,850 | 2 | \$8,600 | 1 |
| | | | Trim jig | \$2,918 | 1 | | |
| 7307-1000-138 | Right/left rear frame rail mounting plate | Stamping | Complete progressive die | \$36,086 | 1 | \$650 | 1 |
| 7307-1020-135 | Left front frame rail | Extrude | Extrusion tooling | \$46,850 | 2 | \$6,500 | 1 |
| 7307-1020-136 | Right front frame rail | | Trim jig | \$2,506 | 1 | | |
| 7307-1020-223 | Left frame rail mounting plate | Stamping | Complete progressive die | \$43,803 | 1 | \$850 | 1 |
| 7307-1020-224 | Right frame rail mounting plate | | | | | | |
| 7307-1011-001 | Left/right front rail mounting | Stamping | Complete progressive die | \$43,627 | 1 | \$1,450 | 1 |
| 7307-1011-003 | Left/right front rail mounting cover | Stamping | Complete progressive die (2 out) | \$59,154 | 1 | \$1,250 | 1 |
| 7305-0900-137 | Left, front, inner frame rail transition | Die cast | Casting mold | \$184,000 | 1 | \$25,500 | 1 |
| | | | Trim die | \$113,428 | 1 | | |
| 7305-0900-138 | Right, front, inner frame rail transition | Die cast | Casting mold | \$190,000 | 1 | \$25,500 | 1 |
| | | | Trim die | \$113,428 | 1 | | |
| 7307-0900-141 | Left, rear, inner frame rail transition | Die cast | Casting mold | \$195,000 | 1 | \$28,500 | 1 |
| | | | Trim die | \$117,447 | 1 | | |
| 7307-0900-142 | Right, rear, inner frame rail transition | Die cast | Casting mold | \$201,000 | 1 | \$28,500 | 1 |
| | | | Trim die | \$117,447 | 1 | | |
| 7306-0810-123 | Left rocker sill extrusion | Extrude | Extrusion tooling | \$51,412 | 2 | \$31,750 | 1 |
| 7306-0810-124 | Right rocker sill extrusion | | Trim jig | \$3,655 | 1 | | |
| 7305-1200-209 | Left front frame rail outer transition | Die cast | Casting mold | \$179,000 | 1 | \$25,500 | 1 |
| | | | Trim die | \$111,602 | 1 | | |
| 7305-1200-210 | Right front frame rail outer transition | Die cast | Casting mold | \$185,000 | 1 | \$25,500 | 1 |
| | | | Trim die | \$111,602 | 1 | | |
| Floor | | | | | | | |
| 7306-0830-124 | Left/right, small outer floor extrusion | Extrude | Extrusion tooling | \$53,122 | 2 | \$1,500 | 1 |



LOTUS ARB LWV PROGRAM

| | | | | | | | |
|---|---|----------|--------------------------|-------------------------|------------|------------------------|------------|
| 7306-0840-010 | Left/right, large outer floor extrusion | | Trim jig | \$2,363 | 1 | \$1,600 | 1 |
| 7306-0830-125 | Left/right, small floor crossmember | Extrude | Extrusion tooling | \$46,280 | 2 | \$15,900 | 1 |
| | | | Trim jig | \$3,115 | 1 | | |
| 7306-0830-126 | Left/right, small inner floor extrusion | Extrude | Extrusion tooling | \$53,122 | 2 | \$1,600 | 1 |
| 7306-0840-012 | Left/right, large inner floor extrusion | | Trim jig | \$2,041 | 1 | \$1,750 | 1 |
| 7306-0840-011 | Left/right, large floor crossmember | Extrude | Extrusion tooling | \$47,134 | 2 | \$17,300 | 1 |
| | | | Trim jig | \$3,331 | 1 | | |
| 7306-0850-000 | Left/right, fore/aft floor extrusions | Extrude | Extrusion tooling | \$44,854 | 2 | \$17,600 | 1 |
| | | | Trim jig | \$3,223 | 1 | | |
| 7306-0860-000 | Center tunnel bracket | Stamping | Complete progressive die | \$25,733 | 1 | \$650 | 1 |
| Totals | | | | \$ 26,017,503.00 | 253 | \$ 2,102,900.00 | 121 |
| Annual (amortized over 3 years) | | | | | | \$9,373,468 | |
| Per BIW (amortized over 3 years) | | | | | | \$156 | |
| Annual (amortized over 5 years) | | | | | | \$5,624,081 | |
| Per BIW (amortized over 5 years) | | | | | | \$94 | |

7.1.1 Closures Manufacturing Report

A study was done to investigate the impact of higher volumes on the manufacturing cost of the low mass multi-material body. The volume was increased from 60,000 units per year to 400,000 units per year. The results of this study, including the complete plant layout and financial assessments, are detailed in the following sections. The general findings are summarized below.

The per unit cost of amortizing the required new BIW manufacturing facility over a five year time period dropped from \$176 per unit (\$52,768,700 BIW plant cost amortized over 5 years of production @ 60,000 units/year) to \$85 per unit (\$171,653,707 for two 200,000 units/year BIW plants amortized over 5 years of production @ 400,000 units per year). The labor cost is \$116 per unit for the 400,000 units per year volume (listed in section 8.1.4.) vs. \$108 per unit for the 60,000 units per year volume (\$6,495,200 from Table 9.2.a divided by 60,000 units per year). The cycle time to build one body in white decreased from 190 seconds (60,000 units/year) to 70 seconds (400,000 units/year). The higher labor cost was due to the proportionally greater number of employees (> 190/70 cycle time ratio) required to support the increased capacity plant.

The full study can be found below.

Purpose of Study:

This study provides an overview about the characteristics of a Body Shop to build annually 400,000 units/year of the LWV (Light Weight Vehicle).

Due to the premature stage of the program we will not enter into the level of detail as typically done. In areas of uncertainty we will make assumptions and/or suggestions.

The assumption was made that it is advisable to split the 400,000 annual volume into two separate identical plants:

Plant A 200,000/yr
Plant B 200,000/yr

In the following we list the advantages of such “fractional” split production:

- Higher feasibility
 - Respond to change in demand by slowing down one plant only
- Easier model change

- Rebuild plant A, phase out Plant B →no interruption
- Local advantages
 - US West Coast – East Coast
 - US – Mexico
 - US – China
 - US – Europe
 - Under one roof (same facility)
- Downtime risk reduction
 - Strike, power outage, storm

In the following we display results and findings based on:

Plant A = 200,000 units/year

In the summary section, pages XX-YY, we summarize all published figures to their volume for:

Plants A&B = 400,000 units/year



Mike Leslie

October 17, 2011

Supervisor Process & Simulation

EBZ Engineering, Inc.

110 South Blvd. W, Suite 100

Rochester Hills, MI 48307

(248) 299-0500

A G E N D A

1. General Assumptions
 2. Process & Layout
 - 2.1. Efficiencies
 - 2.2. Timing Sheets
 - 2.3. Tool Content
 - 2.4. Conveyor Concept
 - 2.5. Buffer Concept
 - 2.6. Station Layouts
 - 2.7. Body Shop Layout
 - 2.8. Body Shop Layout
 3. Facility
 4. Labor Requirements
 5. Logistic Concept
 6. Quality Concept
 7. Maintenance Concept
 8. Investment/Costs
- D. 2-Plant Layout

Attachments

- A. Tool Content
Station_Tool_Content_02-28-11.xls
- B. Station Layouts
Lotus_ARB_LWV_Station_Layout_02-28-11.ppt
- C. System Layout
Lotus_LWV_Layout_02-28-11.dxf

1. General Assumptions

- Two identical Green Field Plants in USA, each producing 200,000 units/year
- 2-shift operation, 10 hr/shift
- Highly automated production system
- Single model, no derivatives
- New bonding technology FSB (FRICTION STIR BONDING)
- Materials aluminum, magnesium, High Strength Steel, composites
- No closures considered in study, BIW only
- Cycle time is 70.4 seconds at 85% body shop efficiency
- Transportation time is 13 seconds (Underbody Line, Framing Line)
- Planned SOP: 2020

2. Process & Layout

2.1. Efficiencies – 3 main factors drive assembly plant efficiency

2.1.1. Technical equipment generally has an efficiency factor of 99% or higher

(a worker is considered 100%)

- Combined in a complex manufacturing system of up to 20 connected stations, the efficiency factor goes down to 95%

2.1.2. Further downtimes occur due to organizational problems caused by logistics, environment, or political (strike) events

- Total reduction: 5% → 90%

2.1.3. Overall system related downtimes (interaction of the different zones)

- Reduce total efficiency factors by additional 5%
- Total bodyshop efficiency: 85%

2.1. Total Efficiency

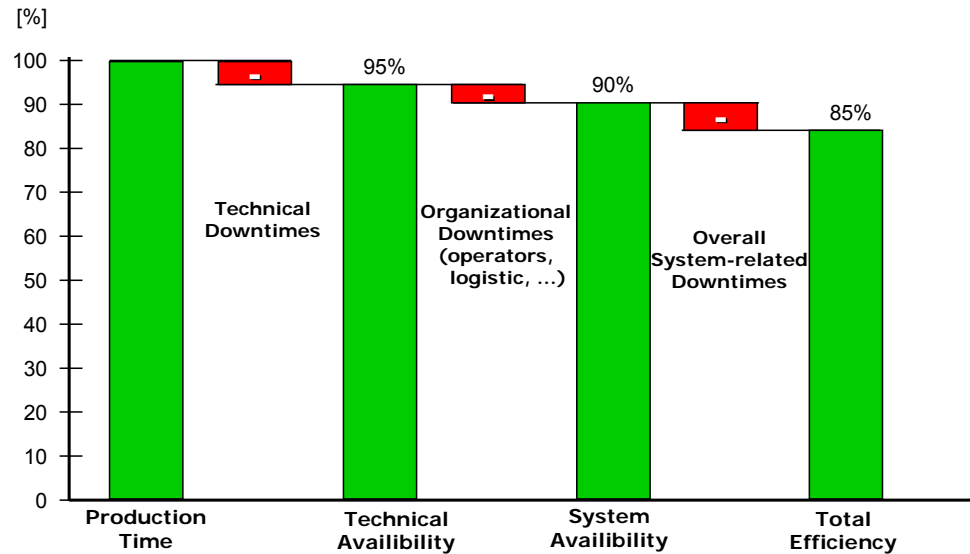

2.2. Timing Sheets Per Station

2.2.1. Cycle Time

- Cycle time: 70.4 seconds

2.2.1. Cycle Time Computation

Plants A & B

200K Assemblies Annually – 5 day production

| | | |
|--------------------|---------|-------------|
| Net Parts per Year | 200,000 | Enter |
| Shifts per day | 2 | Enter |
| Hours per shift | 9.5 | Enter |
| Days per Year | 242 | Enter |
| Days per week | 5 | Enter |
| Efficiency | 85% | Enter |
| Hours per Day | 19 | Calculation |
| Hours per Year | 4598 | Calculation |
| Net Parts per Day | 826 | Calculation |



| | | |
|-------------------------------|--------------|-------------|
| Net Parts per Week (ref only) | 4132 | Calculation |
| Net Parts per Hours | 43 | Calculation |
| Net Cycle Time Seconds | 82.76 | Calculation |
| Gross Parts per Year | 235,294 | Calculation |
| Gross Parts per Hour | 51 | Calculation |
| Gross Cycle Time Seconds | 70.35 | Calculation |

2.3. Tool Content Sheets Per Station

- Detailed Tool Content illustrated for each station, see file
- *02 Process and Layout / 2.4 Tool Content*

2.4. Conveyor Concept

2.4.1. Sub Assemblies

- Part loading by operator or robot
- Part handling by robot

2.4.2. Under Body Line

- Part loading by robot
- Transfer by lift-and-carry

2.4.3. Cross Transport

- Skid transport on belt conveyor
- Skid return overhead
- 2 elevators

2.4.4. Framing Line

- Skid transport on power rollers
- Same skids as 2.4.3
- Total 110 skids + 2 cross transfers in system

2.4.5. After Framing Line

- Elevator to overhead Electric Motorized System (EMS)
- Not included in this study

2.5. Buffer Concept

- Main lines disconnected with buffers
- Buffer sizes: 10 parts equals 12 min
- Buffers half full:
 - Fill up buffer when production line after buffer comes to a halt
 - Discharge buffer when production line in front of buffer stops

2.6. Station Layouts

- Station Layouts describe:
 - Parts loaded
 - Workers
 - Bins
 - Equipment
 - Conveyor system

See file: *02 Process and Layout / 2.6 Station Layouts*

2.7. Body Shop Layout

- Detailed System Layout

See file: *02 Process and Layout / 2.7 System Layout*

2.8. Body Shop Layout

See file: *02 Process and Layout / 2.8 2-Bodyshop Layout*

3. Facility

- The total space required for body shop (one plant) is 363,282 sq. ft.
- This includes:
 - CMM Room
 - Break room
 - Locker/restroom
 - Maintenance Area
 - Tool shop (repair)
 - Logistic preparation area

4. Labor Requirements

- The labor force follows a special revolving shift model:
 - Operators work 10 hrs x 4 days = 40 hrs/wk
 - Total system operating time:
 - 5 days x 2 shifts x 10 hrs = 100 hrs/wk
 - People needed for each manual workplace:
 - $100 \div 40 = 2.5/\text{wk}$
- The following labor force is required to run the body shop per shift:
 - Direct workers: 61
 - Indirect workers:
 - Maintenance 35
 - Logistics 40

5. Logistic Concept

5.1. Main Features

- All bins and racks according to part size
- Number of part bins for (1) week production (8260 parts for 2 plants)
 - (2) days supply in plant
 - (2) days transportation
 - (1) day at supplier's plant
- Shooter technology for small parts
- Fork truck transportation
- Preparation area close to line to connect assembly line to warehouse
- Aisle widths:
 - Main aisles 15 ft.
 - Logistic aisles 12 ft.
 - Maintenance aisles 6 ½ ft.
 - No one-way traffic

5.2. Staff needed: 40 forklift drivers/shift

Shooter Technology

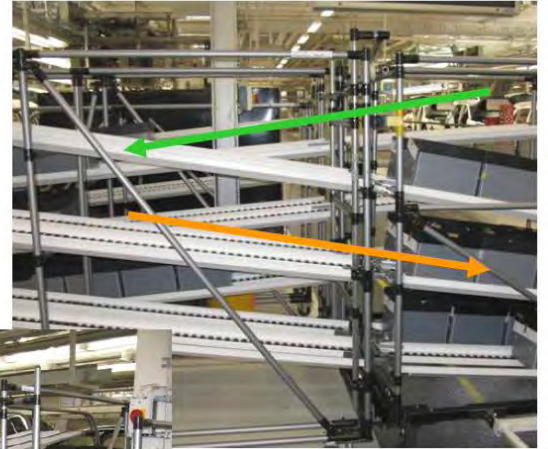

6. Quality Concept

6.1. Philosophy

- Keeping up quality is the responsibility of each worker and member working in the plant
- See Chart (Quality Management Concept)

6.2. (2) Quality Assurance Methods

a. In-line Quality Check

- (4) in line vision stations provide quality data:
 - Station UB-280 End of Underbody Line
 - Station SA-70L End of LH Body Side Line
 - Station SA-70R End of RH Body Side Line
 - Station FR-260A/B End of Framing Line
- Each station is equipped with (2) vision cameras attached to robot arms
- Each camera can shoot up to $178/3.5 = 50$ different spots which is 100 per station

b. Off-line Quality Check

- A CMM room is attached to the body shop which is equipped with (1) 2-arm 20 ft CMM machine and (2) 1-arm 10 ft CMM machines
- We recommend to check (1) underbody per shift and (1) full BIW per 2 shifts (one day)

6.1. Quality Management Concept

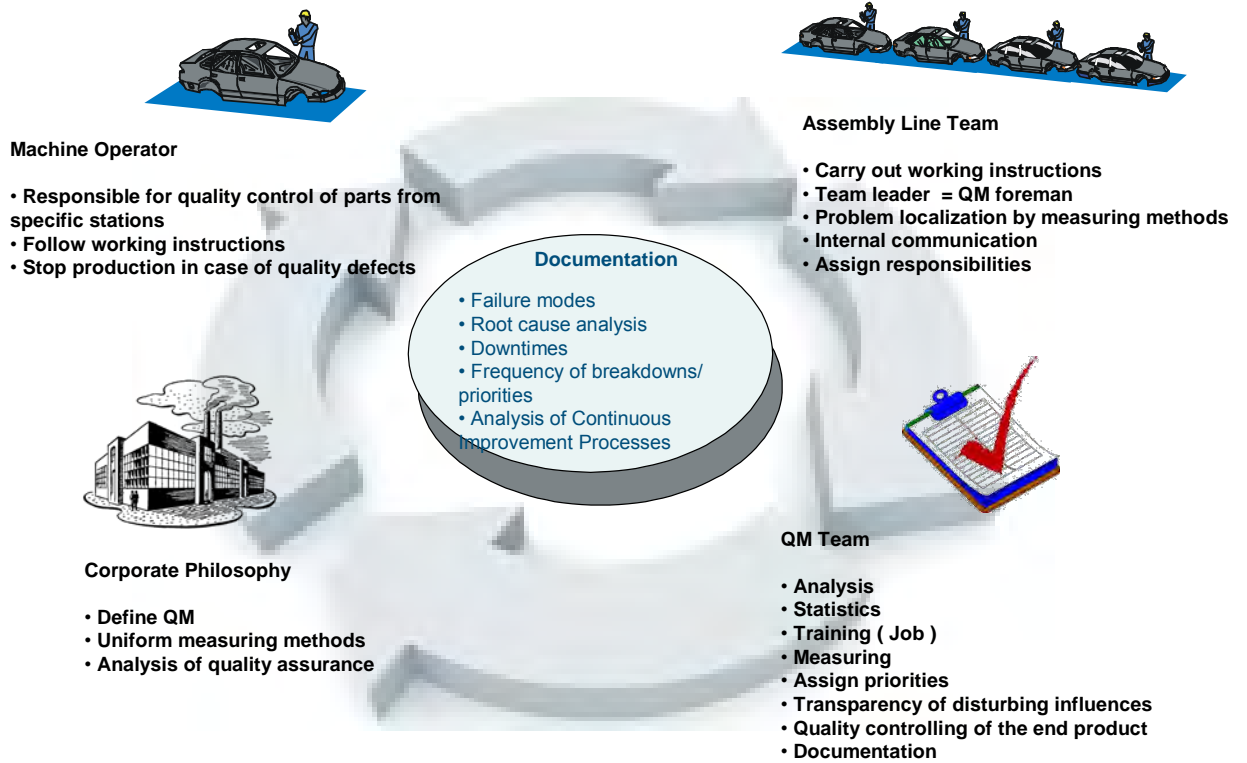

7. Maintenance Concept

- 3 Main Goals:
 - a. High quality product
 - b. High uptime
 - c. Reduction maintenance costs

- Key element is the preventive maintenance:
AVOID THE PROBLEM INSTEAD OF FIXING IT

7. Maintenance Concept

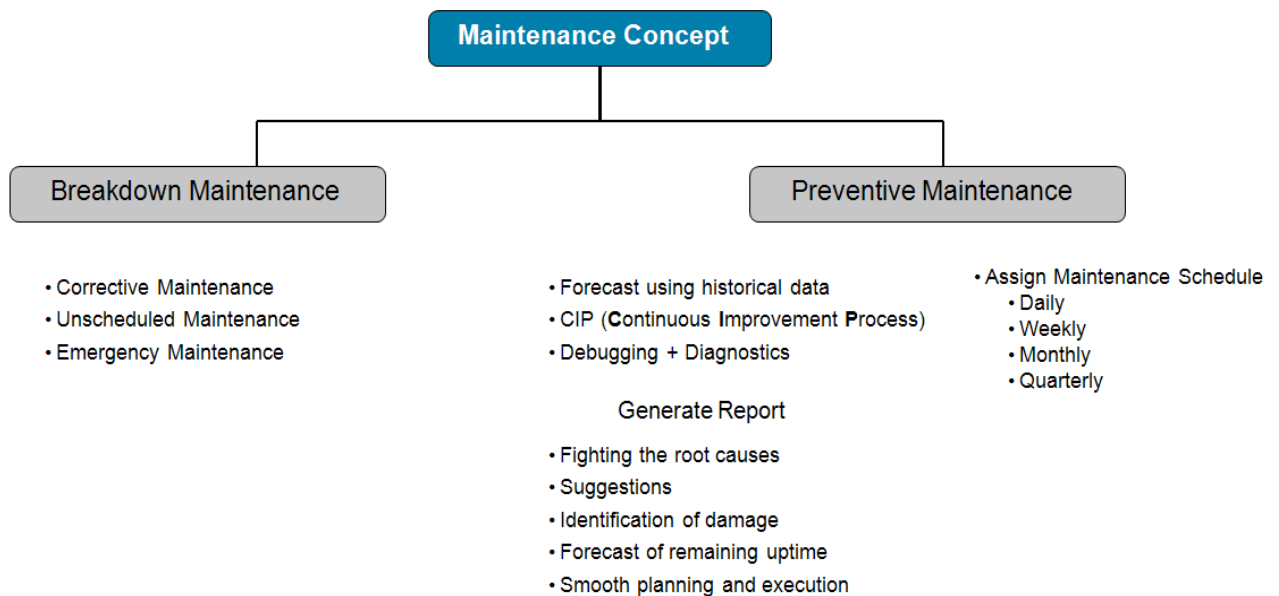

8. Investment/Costs

| | | | |
|------------------------------------|-----------------------|-----------|----|
| 8.1. Labor Cost per Shift | | | |
| Plant A | | | |
| Plants A&B | | | |
| 8.1.1. Assembly Workers | | | |
| • 10 hrs x 61 workers x \$22.00 = | \$ 13,420 | | |
| • Fringe benefits: 40% = | \$ 5,368 | | |
| | | | |
| • Total labor: | | \$ 18,788 | \$ |
| 8.1.2. Maintenance | | | |
| • 10 hrs x 35 workers x \$35.00 = | \$ 12,250 | | |
| • Fringe benefits: 40% = | \$ 4,900 | | |
| | | | |
| • Total maintenance: | | \$ 17,150 | \$ |
| 8.1.3. Logistic | | | |
| • 10 hrs x 40 workers x \$18.00 = | \$ 7,200 | | |
| • Fringe benefits: 60% = | \$ 4,320 | | |
| | | | |
| • Total logistic: | | \$ 11,520 | \$ |
| 8.1.4. Total Labor Cost per Unit | | | |
| | | | |
| • Total cost per shift: | | \$ 47,458 | \$ |
| ÷ 413 units per shift (Plant A) | | | |
| ÷ 826 units per shift (Plants A&B) | | | |
| • Total labor cost per unit: | | \$ | \$ |
| <u>115.91/unit</u> | <u>\$ 115.91/unit</u> | | |

| 8.2. Capital Equipment Plants A&B | | | Plant A | Plant B |
|--------------------------------------|------------------|--------------------|---------------|--------------|
| | | Amortization (yrs) | | |
| 8.2.1. | Subassembly Line | 5 | \$ 30,811,000 | \$28,461,600 |
| | | | | |
| | | | | \$60,272,560 |
| 8.2.2. | Underbody Line | 5 | \$ 25,361,400 | \$23,601,400 |
| | | | | |
| | | | | \$48,962,800 |
| 8.2.3. | Framing Line | 5 | \$ 20,389,000 | \$19,258,100 |
| | | | | |
| | | | | \$39,647,100 |
| 8.2.4. | Conveyors | 5 | \$ 6,089,000 | \$6,089,000 |
| | | | | |
| | | | | \$12,178,000 |
| 8.2.5. | Bins & Racks | 5 | \$ 4,028,000 | \$ 4,028,000 |
| | | | | |
| | | | | \$ 8,056,000 |
| TOTAL | | | | |
| Maintenance w/o Labor 1.5%/yr | | | | |
| <u>\$ 2,536,747</u> | | | | |
| TOTAL (÷ 2,000,000) | | | | |
| \$171,653,707 | | | | \$85.83 |
| CMM Equipment / Tool Shop 7 | | | \$ 5,700,000 | \$5,700,000 |
| <u>\$11,400,000</u> | | | | |

Maintenance w/o Labor 1.5%/yr
\$150,000

TOTAL (÷ 2,800,000)
 \$11,550,000 \$ 4.13

TOTAL CAPITAL EQUIPMENT COST
\$ 92.14

8.3. Utility Costs
 \$ 186.00

8.4. Cost Summary

| \$/Unit | | (estimate) | \$ |
|-------------------|-----------|------------|------------------|
| Material | | | |
| 2,100 | | | |
| | Scrap: 1% | | <u>\$</u> |
| <u>210</u> | | | |
| | | | \$ 2,310.00 |
| Labor | | | |
| | | | \$ 115.91 |
| Capital Equipment | | | |
| | | | \$ 92.14 |
| Utilities | | | |
| <u> </u> | | | <u>\$ 186.00</u> |
| TOTAL COST | | | |
| | | | \$ 2,704.05 |



LOTUS ARB LWV PROGRAM

S,G&A: 7%
\$ 189.28

Interest: 5% \$46,848,848
\$ 135.20

GRAND TOTAL COST PER BIW

\$ 3,028.53



LOTUS ARB LWV PROGRAM

9.2.1. Cost Breakdown: Sub Assembly

Proposal No.
Date: 170C11

PROPOSAL BREAKDOWN
SHEET

EBZ USA

| CUSTOMER: LOTUS | | PROJECT DESCRIPTION: ARB LWV ASSEMBLY BODY SHOP SYSTEM | | | | | | CYCLE TIME: JPH | | | | | | | |
|--------------------|-------------------------|--|---------------|--------------|--------------|--------------|-----------|-----------------------|--------|-------------------------------|---------------|--------------|--------------|-------------|----------|
| CUSTOMER RFQ # N/A | | 400,000/Y | | | | | | *** SUB ASSEMBLES *** | | | | | | | |
| OP # | DESCRIPTION | TOOLING | | | | | | REMARKS | LEADER | CAPITAL TOOLING | | | | | |
| | | MECH. DESIGN | CONTR. DESIGN | PURCH. ITEMS | CONST. LABOR | CONTR. LABOR | TRYOUT | | | MECH. DESIGN | CONTR. DESIGN | PURCH. ITEMS | CONST. LABOR | REMARKS | |
| SA-5 | FRONT AND REAR BUMPER | \$18,700 | \$6,200 | \$31,500 | \$96,000 | \$11,200 | \$8,000 | 2-STATION | G | SAFETY FENCE, GATES, CURTAINS | \$62,000 | \$21,000 | \$265,000 | \$158,000 | |
| SA-10 | FRONT/REAR RAIL ASSY | \$28,750 | \$7,500 | \$41,500 | \$78,800 | \$17,500 | \$12,000 | 2-STATION | H | ROBOT SIMUL., PROG. & DRESS | \$225,000 | \$358,000 | \$120,000 | \$55,000 | |
| SA-15 | AMB PLR QTR DRR/LWR | \$86,000 | \$21,500 | \$135,000 | \$188,000 | \$45,000 | \$27,000 | 2-STATION | I | SYSTEM LAYOUT & INSTAL. DWG. | \$50,000 | | | | |
| SA-20 | REAR COMPT CM ASSY | \$24,500 | \$4,500 | \$29,000 | \$57,500 | \$16,000 | \$7,500 | 2-STATION | J | WELD CONTROLLERS | N/A | N/A | \$56,000 | \$2,500 | 4-REQD |
| SA-25 | CMBR LADDER BLD PHASE-1 | \$49,000 | \$15,500 | \$69,000 | \$110,000 | \$39,000 | \$15,500 | DUAL SET | K | WELD GUNS | N/A | N/A | \$85,000 | \$2,700 | 4-REQD |
| SA-30 | CMBR SEQ SET PHASE 2 | \$31,000 | \$10,500 | \$20,000 | \$38,280 | \$10,300 | \$4,200 | | K | E/E CHANGERS | N/A | N/A | \$80,000 | \$18,000 | 14-REQD |
| SA-35 | ASM PANEL REAR END | \$24,900 | \$7,200 | \$27,000 | \$60,000 | \$20,700 | \$10,500 | 2-STAGE | M | TIP DRESSERS/TORCH CLEANERS | \$3,200 | N/A | \$36,000 | \$16,000 | 10-REQD |
| SA-40R | SIDE RAIL ASM-RH | \$46,700 | \$13,700 | \$69,000 | \$122,000 | \$41,500 | \$18,000 | | N | AIR / WATER HEADERS & VALVES | N/A | N/A | \$400,000 | \$90,000 | |
| SA-40L | SIDE RAIL ASM-LH | N/C | N/C | \$69,000 | \$122,000 | \$41,500 | \$18,000 | | O | P.L.C. PANEL VIEW, HMI & ENCL | N/A | \$375,000 | \$550,000 | \$225,000 | 33-REQD |
| SA-45 | ASM WHL HSE RH/LH | \$31,500 | \$6,800 | \$62,000 | \$115,000 | \$28,000 | \$16,000 | | P | DISPENSING EQUIPMENT | N/A | N/A | \$2,000,000 | \$80,000 | 27-REQD |
| SA-50-S | ASM DASH | \$46,000 | \$8,000 | \$58,000 | \$118,000 | \$35,000 | \$145,000 | | R | 7TH AXIS SLIDE SYSTEM | \$5,000 | N/A | \$80,000 | \$8,800 | 1-REQD |
| SA-60 | REAR SEAT ASSY | \$38,500 | \$11,000 | \$44,000 | \$177,000 | \$31,000 | \$14,000 | 2-STAGE | S | CONVEYOR-GRAVITY | N/A | N/A | N/A | N/A | |
| SA-65H | PRT WH ASM-RH | \$35,000 | \$8,200 | \$55,200 | \$88,500 | \$19,500 | \$10,400 | | S | BALCONIES & G-HEAD STRUCT | \$15,000 | N/A | \$50,000 | \$22,000 | 4-REQD |
| SA-68L | PRT WH ASM-LH | N/C | N/C | \$55,200 | \$88,500 | \$19,500 | \$10,400 | | S | SHUTTLE SYSTEMS 2-STA | N/A | N/A | N/A | N/A | |
| SA-70R | BODY SIDE IN/OTR-RH | \$130,000 | \$26,000 | \$225,000 | \$310,000 | \$122,000 | \$74,000 | COMPLETE CELL | U | ROBOTS-WELDING MIG/BRAZE | N/A | N/A | \$550,000 | \$13,000 | 8-REQD |
| SA-70L | BODY SIDE IN/OTR-LH | N/C | N/C | \$225,000 | \$310,000 | \$122,000 | \$74,000 | COMPLETE CELL | V | ROBOTS-MAT HANDLING | N/A | N/A | \$6,900,000 | \$245,000 | 116-REQD |
| SA-75R | A PLR/DASH TRANS | \$22,800 | \$5,100 | \$45,000 | \$80,000 | \$25,000 | \$11,500 | | U | SPIR UNITS | N/A | N/A | \$400,000 | \$5,000 | 4-REQD |
| SA-79L | A PLR/DASH TRANS | N/C | N/C | \$45,000 | \$80,000 | \$25,000 | \$11,500 | | U | ROBOTS DISPENSING | N/A | N/A | N/A | N/A | |
| SA-80 | BODY SIDE OTR RH/H | \$27,000 | \$6,200 | \$73,000 | \$136,020 | \$31,500 | \$7,100 | 2-STA | U | TRUCKS TECH INDU UNITS | N/A | N/A | \$80,000 | \$18,000 | 4-REQD |
| SA-85 | B-PILLAR OTR RH/H | \$16,500 | \$3,500 | \$18,500 | \$44,500 | \$9,500 | \$9,000 | SINGLE CELL | U | PLC-TAP SYSTEM | N/A | N/A | \$2,300,000 | \$35,000 | 33-REQD |
| | | | | | | | | | U | MANIPULATOR/LOAD ASSIST | \$15,000 | N/A | \$18,000 | \$15,000 | 4-REQD |
| | | | | | | | | | U | FSJ SYSTEM | N/A | N/A | \$4,900,000 | \$85,000 | 49-REQD |
| | | | | | | | | | U | CONUT RUNNERS BUMP STYLE | N/A | N/A | \$150,000 | \$8,000 | 5-REQD |
| | | | | | | | | | U | VISION SYSTEM | N/A | N/A | N/A | N/A | |
| | | | | | | | | | U | SYSTEM LIGHTING | N/A | N/A | \$90,000 | \$80,000 | |
| | | | | | | | | | U | INDEX TABLES | N/A | N/A | N/A | N/A | |
| | | | | | | | | | U | PEDESTAL WELDER | N/A | N/A | N/A | N/A | |
| TOTALS: | | \$627,850 | \$182,540 | \$1,464,900 | \$2,370,100 | \$714,700 | \$508,600 | | | TOTALS: | \$405,200 | \$731,000 | \$19,280,000 | \$1,122,000 | |

| LEGENDS | | MISCELLANEOUS COSTS | | |
|---------|---|---------------------|--|--|
| A | Mech. Design Costs (ie customer specifications supplied for this system) | AA | Tear Down & Crating for shipping | |
| B | Controls Design Costs (ie customer specifications applied to this system) | AB | Transportation Charges | |
| C | Purchased Component Cost - Tooling | AC | Training at EBZ USA (*) eight hour/day included | |
| D | Construction Labor - Fab, Machine, Assembly & Coat | AD | Operation & Maintenance Manuals | |
| E | Controls Labor - Pipe Wire related to specific tooling | AE | 20 Hour City run to verify system operation | |
| F | Cost for Mechanical Controls Dwg- including product 15-fig | AF | Includes dimensional layout of (2) assemblies & (3) for Weld Integrity (destructive testing) | |
| G | Safety Fence, Gates, Light Screens, Mks & Guards | AG | System compliance (dual/consecutive operation) | |
| H | Robot Simul., Programming and Dress | AH | EBZ USA standard one year warranty is included per EBZ USA Specification | |
| I | System Layout and Installation Drawings | AI | Complete system integration in customer plant utilizing EBZ USA personnel. All PDP and utility areas supplied by the customer. | |
| J | Weld Controller Installation | AJ | Supervision employing EBZ USA personnel | |
| K | Weld Guns including trim/controls/setting and setup | AK | (2) weeks EBZ USA Technicians provided-not including expenses | |
| L | Welding feedback system (if applicable) | AL | Cycle Charts, Weld Studies & Misc. Process Activities | |
| M | Tip Dressers and/or Torch Cleaners | AM | | |
| N | Air & Water Headers, Pipes and Valves | AN | | |
| O | Processors, Panel View, HMI, Power sources, Cable Tray, and Panels | AO | | |
| P | Stainless and Adhesive Dispensing equipment | AP | | |
| Q | Complete reading system packages/installation | | | |
| R | Belt and Roller Conveyors, Power and Gravity Feed | | | |
| S | Balconies, Overhead Structures, Rails and Trusses | | | |
| T | Hydraulic Pump Units, Valves and Accessories | | | |
| U | Welding Robot-Mix systems including installation | | | |
| V | Robots MH including mechanical installation | | | |
| X | | | | |
| Y | | | | |
| Z | | | | |

| Hourly Costs (E Change Rates) | | Hourly Rate |
|-------------------------------|--------------------------------|--------------------|
| AI | Customer Trades Person | \$60.00 + Expenses |
| AI | Customer Designer / Technician | \$60.00 + Expenses |
| AI | EBZ USA Trades Person | \$60.00 |
| AI | EBZ USA Designer / Technician | \$60.00 |

| TOTALS: | | Plant A | Plant B |
|----------------------------|--|---------------------|---------------------|
| TOTAL TOOLING COST | | \$5,648,690 | \$5,295,700 |
| TOTAL CAPITAL TOOLING COST | | \$21,488,200 | \$20,692,900 |
| TOTAL MISC. ITEMS COST | | \$3,473,000 | \$3,473,000 |
| GRAND TOTAL | | \$30,610,890 | \$29,461,600 |

9.2.2. Cost Breakdown: Underbody Line

 Proposal No:
Date: 170C11

 PROPOSAL BREAKDOWN
SHEET

EBZ USA

| CUSTOMER: LOTUS | | PROJECT DESCRIPTION: ARB LWV ASSEMBLY BODY SHOP SYSTEM | | | | | | | CYCLE TIME: JPH: | | | | | | |
|-----------------|------------------------------|--|---------------|--------------|--------------|--------------|-----------|---------|------------------|-------------------------------|--------------|---------------|--------------|--------------|----------------------|
| CUSTOMER RFQ # | | TOOLING | | | | | | | CAPITAL TOOLING | | | | | | |
| OFF | DESCRIPTION | MECH. DESIGN | CONTR. DESIGN | PURCH. ITEMS | CONST. LABOR | CONTR. LABOR | TRYOUT | REMARKS | LEGB# | DESCRIPTION | MECH. DESIGN | CONTR. DESIGN | PURCH. ITEMS | CONST. LABOR | REMARKS |
| UB100 | LOAD STATION | \$6,500 | \$3,900 | \$6,500 | \$17,000 | \$5,200 | \$4,400 | | G | SAFETY FENCE, GATES, CURTAINS | \$66,000 | \$23,000 | \$41,000 | \$22,000 | |
| UB110 | LOAD CMBR | \$23,000 | \$6,500 | \$31,500 | \$68,000 | \$29,500 | \$21,000 | LOAD | H | ROBOT SIMUL. PROG. & DRESS | \$410,000 | \$650,000 | \$222,000 | \$100,000 | |
| UB120 | LOAD SIDE RAILS | \$26,000 | \$2,500 | \$33,000 | \$72,000 | \$31,000 | \$22,000 | LOAD | I | SYSTEM LAYOUT & INSTAL DWGS | \$68,000 | | | | |
| UB130 | IDLE | \$6,500 | \$3,900 | \$6,500 | \$17,000 | \$5,200 | \$4,400 | | J | WELD CONTROLLERS | N/A | N/A | N/A | N/A | |
| UB140 | GEO. SET CMBR FLOOR ASM | \$54,000 | \$17,500 | \$95,000 | \$135,000 | \$38,000 | \$28,000 | GEO SET | K | WELD GUNNS | N/A | N/A | N/A | N/A | |
| UB150 | DASH/WHL. HSERR-REFJ DASH | \$78,200 | \$28,800 | \$110,000 | \$285,000 | \$63,000 | \$28,000 | GEO SET | L | W/ CHANGERS | N/A | N/A | \$520,000 | \$85,000 | 35-REQD |
| UB160 | IDLE | \$4,500 | \$2,500 | \$6,500 | \$17,500 | \$5,200 | \$4,400 | | M | TIP DRESSER/TORCH CLEANERS | N/A | N/A | N/A | N/A | |
| UB170 | RESPOT | \$27,000 | \$4,000 | \$31,000 | \$47,500 | \$13,500 | \$12,500 | | N | AIR / WATER HEADERS & VALVES | N/A | N/A | \$260,000 | \$300,000 | |
| UB180 | RESPOT | \$27,000 | \$4,000 | \$31,000 | \$47,500 | \$13,500 | \$12,500 | | O | PLC PANEL VIEW, RMI & ENCL | N/A | N/A | \$320,000 | \$460,000 | 22-REQD |
| UB190 | RESPOT | \$31,500 | \$5,000 | \$38,500 | \$58,000 | \$18,000 | \$18,000 | | P | DISPENSING EQUIPMENT | N/A | N/A | \$1,100,000 | \$52,000 | 18-REQD |
| UB200 | REAR SEAT /A FLR R/L | \$55,000 | \$13,500 | \$72,000 | \$138,000 | \$33,000 | \$28,000 | GEO SET | P | DISPENSING EQUIPMENT | N/A | N/A | N/A | N/A | MASTIC |
| UB210 | IDLE | \$6,500 | \$3,900 | \$6,500 | \$17,000 | \$5,200 | \$4,400 | | R | CONVEYORS, GRAVITY | N/A | N/A | N/A | N/A | |
| UB220 | FRT WHL HSERL/ CLOSE OUTS | \$82,100 | \$14,100 | \$98,000 | \$156,000 | \$50,700 | \$18,500 | GEO SET | S | RAIL CONIS & OHHEAD STRUCT | N/A | N/A | N/A | N/A | |
| UB230 | RESPOT | \$27,000 | \$4,000 | \$31,000 | \$47,500 | \$13,500 | \$12,500 | | T | TRANSFER SYSTEM | \$65,000 | \$28,000 | \$330,000 | \$510,000 | 1-REQD (18-STATIONS) |
| UB240 | FINL CTR FLR R/L | \$26,400 | \$4,500 | \$18,500 | \$43,080 | \$18,720 | \$9,600 | GEO SET | U | ROBOTS-WELDING MIG | N/A | N/A | N/A | N/A | |
| UB250 | IDLE | \$6,500 | \$3,900 | \$6,500 | \$17,500 | \$5,200 | \$4,400 | | V | ROBOTS-MAT HANDLING | N/A | N/A | \$4,518,000 | \$145,000 | 82-REQD |
| UB260 | WHL HSER OTR R/L TUNL RR FLR | \$71,500 | \$18,000 | \$109,000 | \$188,000 | \$65,000 | \$27,000 | GEO SET | W | SPRZ UNITS | N/A | N/A | \$800,000 | \$18,000 | 8-REQD |
| UB270 | FINL CTR FLR R/L | \$26,400 | \$4,500 | \$18,500 | \$43,080 | \$18,720 | \$9,600 | GEO SET | X | ROBOTS-DISPENSING | N/A | N/A | N/A | N/A | |
| UB280 | IDLE | \$6,500 | \$3,900 | \$6,500 | \$17,500 | \$5,200 | \$4,400 | | Y | 7TH AXIS UNITS | N/A | N/A | N/A | N/A | |
| UB290 | RESPOT | \$27,000 | \$4,000 | \$31,000 | \$47,500 | \$13,500 | \$12,500 | | Z | RIV. TAC SYSTEM | N/A | N/A | \$2,000,000 | \$20,000 | 20-REQD |
| UB300 | RESPOT | \$27,000 | \$4,000 | \$31,000 | \$47,500 | \$13,500 | \$12,500 | | | MANIPULATORS LOAD ASSISTS | N/A | N/A | N/A | N/A | |
| UB310 | RESPOT | \$27,000 | \$4,000 | \$31,000 | \$47,500 | \$13,500 | \$12,500 | | | PS SYSTEM | N/A | N/A | \$3,700,000 | \$83,000 | 37-REQD |
| UB320 | EXT (D) APRL Y | \$31,000 | \$4,200 | \$31,000 | \$65,000 | \$23,000 | \$18,000 | | | PC NUT RUNNERS RUP STYLE | N/A | N/A | N/A | N/A | |
| UB330 | VISION INSPECTION | \$26,000 | \$5,500 | \$43,000 | \$66,000 | \$28,000 | \$17,000 | | | VISION SYSTEM | N/A | N/A | \$900,000 | \$30,000 | 6-REQD |
| | | | | | | | | | | SYSTEM LIGHTING | N/A | N/A | \$82,000 | \$4,000 | 22-REQD |
| | | | | | | | | | | INDEX TABLES | N/A | N/A | N/A | N/A | |
| | | | | | | | | | | PEDESTAL WELDER | N/A | N/A | N/A | N/A | |
| | | | | | | | | | | FLOW SCREW DRIVE UNITS | N/A | N/A | \$70,000 | \$13,000 | 2-REQD |
| | | | | | | | | | | STUD INSERTION UNITS | N/A | N/A | \$107,500 | \$33,000 | 6-REQD |
| TOTALS: | | \$710,100 | \$174,200 | \$902,500 | \$1,657,160 | \$536,840 | \$340,100 | | | TOTALS: | \$669,000 | \$1,021,000 | \$15,165,500 | \$1,515,000 | |

| LEGENDS | |
|---------|---|
| A | Mech. Design Costs to customer specifications supplied for this system |
| B | Customer Design Costs-to customer specifications applied to this system |
| C | Purchased component cost-Tooling |
| D | Construction Labor- Fan, Machine, Assembly & Cost |
| E | Contract Labor- Pipe Wre related to specific tooling |
| F | Cost for Mechanical Controls Design including production |
| G | Safety Fence, Gates, Light Screens, Mats & Curtains |
| H | Robot Simul. Programming and Dress |
| I | System Layouts and Installation Drawings |
| J | Weld Controls/Installation |
| K | Weld Cuts including transformers/cabling and setup |
| L | Welding feedback system (if applicable) |
| M | Tip Dresser and/or Torch Cleaners |
| N | Air & Water Headers, Pipe and valves |
| O | Processors, Panel View, RMI, Power sources and Panels |
| P | Sealant and Address Dispensing equipment |
| Q | Complete tooling system packages/installation |
| R | Belts and Roller Conveyors, Power and Gravity Feed |
| S | Balconies, Overhead Structures, Rais and Trolley |
| T | Hydraulic Pump Unit, Valves and Accessories |
| U | Welding Robotic-MIG systems including installation |
| V | Robotic MH including mechanical installation |
| W | |
| X | |
| Y | |
| Z | |

| MISCELLANEOUS COSTS | | |
|---------------------------------|-------------|-----------------------------------|
| DESCRIPTION | COST | REMARKS |
| AA CRATING & LOADING | \$67,000 | |
| AB FREIGHT | \$135,000 | |
| AC TRAINING @ EBZ USA | N/A | FDB CALIFORNIA-USA |
| AD OPPER /MAINT. MANUALS | \$31,000 | QUOTED ON REQUEST |
| AE 20 HR. RUN | \$37,000 | |
| AF 30 PECE CAPABILITY STUDY | \$675,000 | DEPENDENT ON PRODUCT AVAILABILITY |
| AG 300 PECE TRYOUT-PART BUY-OFF | \$330,000 | DEPENDENT ON PRODUCT AVAILABILITY |
| AH ONE YEAR (12) MONTH WARRANTY | N/A | EBZ |
| AI INSTALLATION | \$1,115,000 | PPDS INCLUDED |
| AJ INSTALLATION SUPERVISION | \$80,000 | |
| AK START UP ASSISTANCE | \$330,000 | |
| AL DESIGN PROCESSING | N/A | |
| AM | | |
| AN | | |
| AO | | |
| AP | | |
| TOTALS: | | \$2,710,000 |

| Hourly Costs (EC Change Rates) | Hourly Rate |
|-----------------------------------|--------------------|
| At Customer Trades Person | \$60.00 + Expenses |
| At Customer Designer / Technician | \$60.00 + Expenses |
| At EBZ USA Trades Person | \$60.00 |
| At EBZ USA Designer / Technician | \$60.00 |

| | Plant A | Plant B |
|-----------------------------------|--------------|--------------|
| TOTAL TOOLING COST | \$4,320,900 | \$3,701,900 |
| TOTAL CAPITAL TOOLING COST | \$18,330,500 | \$17,189,500 |
| TOTAL MISC. ITEMS COST | \$2,710,000 | \$2,710,000 |
| GRAND TOTAL | \$26,361,400 | \$23,601,400 |



LOTUS ARB LWV PROGRAM

9.2.3. Cost Breakdown: Framing Line

Proposal No.
Date: 17OC11

PROPOSAL BREAKDOWN
SHEET

EBZ USA

| CUSTOMER: LOTUS | | PROJECT DESCRIPTION: | | | | | | ARB LWV ASSEMBLY BODY SHOP SYSTEM | | 400,000yr | | | | CYCLE TIME: | | | |
|-----------------|---------------------------------|----------------------|---------------|--------------|--------------|--------------|----------|-----------------------------------|--------|-------------------------------|--------------|---------------|-----------------|--------------|-------------|--|--|
| CUSTOMER RFQ # | | N/A | | | | | | ***FRAMING LINE BODY SYSTEM*** | | | | | | JPH: | | | |
| TOOLING | | | | | | | | | | | | | CAPITAL TOOLING | | | | |
| OF # | DESCRIPTION | MECH. DESIGN | CONTR. DESIGN | PURCH. ITEMS | CONST. LABOR | CONTR. LABOR | TRYOUT | REMARKS | LEGEND | DESCRIPTION | MECH. DESIGN | CONTR. DESIGN | PURCH. ITEMS | CONST. LABOR | REMARKS | | |
| FR100 | IDLE | \$1,800 | \$1,200 | \$4,500 | \$3,200 | \$2,400 | \$1,800 | | G | SAFETY FENCE, GATES, CURTAINS | \$35,000 | \$12,000 | \$135,000 | \$88,000 | | | |
| FR110 | BODY FRAME STATION | \$96,000 | \$20,160 | \$187,200 | \$205,000 | \$84,600 | \$28,500 | GEO SET | H | ROBOT SIMUL., PROG. & DRESS | \$185,000 | \$276,000 | \$22,000 | \$80,000 | | | |
| FR120 | RES.POT | \$25,000 | \$3,750 | \$31,000 | \$47,500 | \$15,500 | \$12,500 | | I | SYSTEM LAYOUT & INSTAL. DWGS | \$61,000 | | | | | | |
| FR130 | RES.POT | \$25,000 | \$3,750 | \$31,000 | \$47,500 | \$15,500 | \$12,500 | | J | WELD CONTROLLERS | N/A | N/A | N/A | N/A | | | |
| FR140 | RES.POT | \$25,000 | \$3,750 | \$31,000 | \$47,500 | \$15,500 | \$12,500 | | K | WELD GUNS | N/A | N/A | N/A | N/A | | | |
| FR150 | STUD APPLY | \$34,000 | \$5,100 | \$45,000 | \$68,000 | \$23,000 | \$15,000 | | L | W/ DRESSERS/TORCH CLEANERS | N/A | N/A | \$95,000 | \$12,000 | 1-REQD | | |
| FR160 | STUD APPLY | \$34,000 | \$5,100 | \$45,000 | \$68,000 | \$23,000 | \$15,000 | | M | TP DRESSERS/TORCH CLEANERS | N/A | N/A | N/A | N/A | | | |
| FR170 | IDLE | \$1,800 | \$1,200 | \$4,500 | \$3,200 | \$2,400 | \$1,800 | | N | AIR/WATER HEADERS & VALVES | N/A | N/A | \$165,000 | \$190,000 | | | |
| FR180 | GEO SET B/SIDE | \$98,000 | \$27,000 | \$206,000 | \$28,000 | \$112,000 | \$41,000 | | O | P.L.C. PANEL VIEW, HMI & ENCL | N/A | \$225,000 | \$274,000 | \$90,000 | 13-REQD | | |
| FR190 | RES.POT | \$25,000 | \$3,750 | \$31,000 | \$47,500 | \$15,500 | \$12,500 | | P | DISPENSING EQUIPMENT | N/A | N/A | \$430,000 | \$18,500 | 8-REQD | | |
| FR200 | ADHESIVE APPLY | \$32,000 | \$4,500 | \$38,000 | \$51,000 | \$20,000 | \$15,500 | | P | DISPENSING EQUIPMENT-MASTIC | N/A | N/A | \$57,500 | \$3,200 | 1-REQD | | |
| FR210 | ROOF - GEO SET | \$65,000 | \$14,500 | \$80,000 | \$175,000 | \$45,000 | \$20,000 | | R | CONVEYORS-GRAVITY | N/A | N/A | N/A | N/A | | | |
| FR220 | IDLE | \$1,800 | \$1,200 | \$4,500 | \$3,200 | \$2,400 | \$1,800 | | S | BALCONIES & OVERHEAD STRUCT | \$25,000 | N/A | \$38,000 | \$18,000 | 1-REQD | | |
| FR230 | RES.POT | \$25,000 | \$3,750 | \$32,000 | \$94,000 | \$27,000 | \$25,000 | DUAL | U | TRANSFER SYSTEM | N/A | N/A | N/A | N/A | | | |
| FR240 | RES.POT | \$25,000 | \$3,750 | \$32,000 | \$94,000 | \$27,000 | \$25,000 | DUAL | V | ROBOTS-WELDING MIG | N/A | N/A | N/A | N/A | | | |
| FR250 | RES.POT | \$25,000 | \$3,750 | \$32,000 | \$94,000 | \$27,000 | \$25,000 | DUAL | U | ROBOTS-MAT HANDLING | N/A | N/A | \$2,600,000 | \$140,000 | 74-REQD | | |
| FR260 | VISION | \$18,000 | \$3,750 | \$62,000 | \$105,000 | \$27,000 | \$25,000 | DUAL | U | SPR UNITS | N/A | N/A | \$540,000 | \$12,000 | 6-REQD | | |
| FR270 | IDLE | \$1,800 | \$1,200 | \$4,500 | \$3,200 | \$2,400 | \$1,800 | | U | ROBOTS-DISPENSING | N/A | N/A | N/A | N/A | | | |
| FR280 | FRONT/REAR B.M.P.R. MODULE FR.T | \$21,000 | \$10,500 | \$40,000 | \$72,000 | \$32,000 | \$8,400 | BOLT ON GEO | U | 7TH AXIS UNITS | N/A | N/A | \$16,000 | \$12,000 | 2-REQD | | |
| FR290 | REWORK/FINISH VISUAL INSPECT | \$15,000 | \$2,400 | \$72,000 | \$105,000 | \$17,000 | \$7,300 | | U | RIV TAC SYSTEM | N/A | N/A | \$400,000 | \$5,000 | 4-REQD | | |
| FR300 | IDLE | \$1,800 | \$1,200 | \$4,500 | \$3,200 | \$2,400 | \$1,800 | | U | MANIPULATOR/LOAD ASSIST | \$21,000 | N/A | \$30,400 | \$24,000 | 5-REQD | | |
| | | | | | | | | | U | FSJ SYSTEM | N/A | N/A | \$4,400,000 | \$37,000 | 44-REQD | | |
| | | | | | | | | | U | DC NUT RUNNERS BLP-STYLE | N/A | N/A | \$165,000 | \$8,000 | 6-REQD | | |
| | | | | | | | | | U | VISION SYSTEM | N/A | N/A | \$600,000 | \$20,000 | 4-REQD | | |
| | | | | | | | | | U | SYSTEM LIGHTING | N/A | N/A | \$60,000 | \$40,000 | 20-REQD | | |
| | | | | | | | | | U | INDEXABLE DUNNAGE SYSTEMS | N/A | N/A | \$120,000 | \$10,800 | 4-REQD | | |
| | | | | | | | | | U | STUD INSERTION UNITS | N/A | N/A | \$448,000 | \$66,000 | 14-REQD | | |
| | | | | | | | | | U | SURFACE BUFFERS | N/A | N/A | \$30,000 | \$16,000 | 8-REQD | | |
| | | | | | | | | | U | HLITE LAMPS | N/A | N/A | \$28,050 | \$10,830 | 33-SUPPLIED | | |
| TOTALS: | | | | | | | | | | \$598,600 | \$176,660 | \$1,107,700 | \$1,345,000 | \$530,600 | \$317,800 | | |
| | | | | | | | | | | TOTALS: | \$327,600 | \$513,000 | \$11,850,950 | \$902,230 | | | |

| LEGENDS | |
|---------|--|
| A | Mech. Design Costs, to customer specifications supplied for this system |
| AB | Contractor Design Costs, to customer specifications applied to this system |
| C | Purchased component cost - Tooling |
| D | Construction Labor - Fab. Machine, Assembly & Cert. |
| E | Contractor Labor - Pipe Wires related to specific tooling |
| F | Cost for Mechanical/Controls De-bug including product fill-up |
| G | Safety Fence, Gates, Light Screens, Mats & Guards |
| H | Robot Simul. Programming and Dress |
| I | System Layouts and Installation Drawings |
| J | Cost for Mechanical/Controls De-bug including product fill-up |
| K | Weld Guns including transformer/cable and set-up |
| L | Welding feedback system (if applicable) |
| M | Tip Dressers and/or Torch Cleaners |
| N | Air & Water Headers, Pipe and Valves |
| O | Pressions, Panel View, HMI, Power sources and Panels |
| P | Sensors and Adhesive Dispensing equipment |
| Q | Combinic feeding system packages/installation |
| R | Belts and Roller Conveyors, Power and Gravity feed |
| S | Balconies, Overhead Structures, Rails and Trolleys |
| T | Hydraulic Pump Units, Valves and Accessories |
| U | Welding Robots-MIG systems including installation |
| V | Rebots MH including mechanical installation |
| W | |
| X | |
| Y | |
| Z | |

| LEGENDS | |
|---------|---|
| AA | Tear Down & Crating for shipping |
| AB | Transportation Charges |
| AC | Training at EBZ USA (1) eight hour day included |
| AD | Operation & Maintenance Manuals |
| AE | 20 Hour Dry run to verify system operation |
| AF | Includes dimensional layout of (30) assemblies & (3) for Vee'd Integrity (Destructive testing) |
| AG | System confidence buildoff representative operation |
| AH | EBZ USA standard one year warranty is included per EBZ USA Specification |
| AI | Complete System integration in customer plant utilizing EBZ USA personnel. All FDP and utility steps supplied by the customer |
| AJ | Supervision only utilizing EBZ USA personnel |
| AK | (2) weeks EBZ Technicians provided-not including expenses |
| AL | Cycle Charts, Weld Studies & Misc. Process Activities |
| AM | |
| AN | |
| AO | |
| AP | |

| MISCELLANEOUS COSTS | | |
|----------------------------------|-----------|-----------------------------------|
| DESCRIPTION | COST | REMARKS |
| AA CRATING & LOADING | \$90,000 | |
| AB FREIGHT | \$180,000 | FOB CALIFORNIA-USA |
| AC TRAINING @ EBZ USA | N/A | QUOTED ON REQUEST |
| AD OPER. MAINT. MANUALS | \$43,000 | |
| AE 20 HR. RUN | \$61,000 | |
| AF 50 PIECE CAPABILITY STUDY | \$900,000 | DEPENDENT ON PRODUCT AVAILABILITY |
| AG 300 PIECE TRYOUT-PART BUY-OFF | \$475,000 | DEPENDENT ON PRODUCT AVAILABILITY |
| AH ONE YEAR (12) MONTH WARRANTY | N/A | |
| AI INSTALLATION | \$870,000 | PDP'S INCLUDED |
| AJ INSTALLATION SUPERVISION | \$110,000 | |
| AK START-UP ASSISTANCE | \$190,000 | |
| AL DESIGN PROCESSING | N/A | |
| AM | | |
| AN | | |
| AO | | |
| AP | | |
| TOTALS: | | \$2,919,000 |

| Hourly Costs (EC Change Rates) | Hourly Rate |
|-----------------------------------|--------------------|
| At Customer Trades Person | \$60.00 + Expenses |
| At Customer Designer / Technician | \$60.00 + Expenses |
| At EBZ USA Trades Person | \$60.00 |
| At EBZ USA Designer / Technician | \$60.00 |

| | Plant A | Plant B |
|----------------------------|--------------|--------------|
| TOTAL TOOLING COST | \$4,076,360 | \$3,535,700 |
| TOTAL CAPITAL TOOLING COST | \$13,393,840 | \$12,805,400 |
| TOTAL MISC. ITEMS COST | \$2,919,000 | \$2,919,000 |
| GRAND TOTAL | \$20,389,200 | \$19,259,100 |



LOTUS ARB LWV PROGRAM

9.2.4. Cost Breakdown: Body Skid and Transportation Systems

Proposal No:
Date: 170C11

PROPOSAL BREAKDOWN
SHEET

EBZ USA

| CUSTOMER: LOTUS | | PROJECT DESCRIPTION: ARB LWV ASSEMBLY BODY SHOP SYSTEM | | | | | | | CYCLE TIME: 177 | | | | | | |
|-----------------|-------------|--|-----------------------|----------------------|----------------------|----------------------|-------------|-----------|-----------------|--|------------------|-----------------|-----------------|-----------|----------|
| CUSTOMER RFO # | | *** BODY SKID AND TRANSPORTATION SYSTEMS *** | | | | | | | JPH: 20.8 | | | | | | |
| | | TOOLING | | | | | | | CAPITAL TOOLING | | | | | | |
| OP # | DESCRIPTION | A MECH. DESIGN | B CONTR. DESIGN | C PURCH. ITEMS | D CONST. LABOR | E CONTR. LABOR | F TRYOUT | REMARKS | DESCRIPTION | MECH. DESIGN | CONTR. DESIGN | PURCH. ITEMS | CONST. LABOR | REMARKS | |
| | BODY SKIDS | \$28,000 | N/A | \$330,000 | \$475,000 | N/A | \$28,000 | 100 SKIDS | G | SAFETY FENCE, GATES, CURTAINS SYSTEM LAYOUT & INSTAL DWGS | \$18,000 | N/A | \$110,000 | \$90,000 | |
| | | | | | | | | | H | ROLLER BED CONVEYORS | \$32,000 | \$9,000 | \$650,000 | \$425,000 | 24 REQ'D |
| | | | | | | | | | I | OVERHEAD SKID CONVEYOR | N/A | N/A | \$990,000 | \$48,000 | 24 REQ'D |
| | | | | | | | | | J | SKID BODY BELT CONVEYOR | N/A | N/A | \$335,000 | \$87,000 | 1 REQ'D |
| | | | | | | | | | K | BALCONIES & ON FEED STRUCT | N/A | N/A | N/A | N/A | |
| | | | | | | | | | L | SKID LIFTERS (WORKING STAS) | \$28,000 | \$23,000 | \$235,000 | \$310,000 | 23 REQ'D |
| | | | | | | | | | M | BEAR ROLLER BED SYSTEMS | N/A | N/A | \$137,000 | \$16,000 | 24 REQ'D |
| | | | | | | | | | N | CONVEYORS GRAVITY | N/A | N/A | N/A | N/A | |
| | | | | | | | | | O | CROSS TRANSFER SYSTEM | \$58,000 | \$19,000 | \$195,000 | \$135,000 | 2 REQ'D |
| TOTALS: | | \$28,000 | \$0 | \$330,000 | \$475,000 | \$0 | \$28,000 | | TOTALS: | \$167,500 | \$49,000 | \$3,395,000 | \$1,364,000 | | |

| LEGENDS | | MISCELLANEOUS COSTS | |
|---------|--|---------------------|---|
| A | Mech. Design Costs, to customer specifications supplied for this system. | AA | Year Down & Crating for shipping |
| B | Controls Design Costs - to customer specifications applied to this system. | AB | Transportation Charges |
| C | Purchased component cost - Tooling | AC | Training at EBZ USA (1) eight hour day included |
| D | Construction Labor - Fab, Machine, Assembly & Cert. | AD | Operation & Maintenance Manuals |
| E | Controls Labor - Pipe wire related to specific tooling | AE | 20 Hour Dry run or verify system operation |
| F | Cost for Mechanical/Controls De-bug including product fix-up | AF | Includes dimensional layout of (30) assemblies & (3) for Weld Integrity (Destructive testing) |
| G | Safety Fences, Gates, Light Screens, Mats & Guards | AG | System confidence boost/conservative operation |
| H | Robot Sensor, Programming and Drives | AH | EBZ USA standard one year warranty on included per EBZ USA Specification |
| I | System Layouts and Installation Drawings | AI | Complete System integration in customer plant utilizing EBZ USA personnel. All PDP and utility items supplied by the customer |
| J | Weld control installation | AJ | Supervision only utilizing EBZ USA personnel |
| K | Weld Guns including transformer/cabling and set-up | AK | (2) weeks EBZ Technicians provided-not including expenses |
| L | Welding feedback system (if applicable) | AL | Cycle Charts, Weld Studies & Misc. Process Activities |
| M | Tie Drives and/or Touch Cleaners | AM | |
| N | 4" & Water Headers, Pipe and valves | AN | |
| O | Processors, Panel View, HMI, Power sources and Panels | AO | |
| P | Skid and Adhesive Dispensing equipment | AP | |
| Q | Complete loading system package installation | | |
| R | Roll and Roller Components, Flare and Gravity Feed | | |
| S | Balconies, Overhead Structures, Rails and Trolleys | | |
| T | Hydraulic Pump Units, Valves and Accessories | | |
| U | Welding Robots/MC systems including installation | | |
| V | Robots MH including mechanical installation | | |
| W | | | |
| X | | | |
| Y | | | |
| Z | | | |

| Hourly Costs (Ec Change Rates) | Hourly Rate |
|-----------------------------------|--------------------|
| At Customer Trades Person | \$60.00 - Expenses |
| At Customer Designer / Technician | \$60.00 - Expenses |
| At EBZ USA Trades Person | \$60.00 |
| At EBZ USA Designer / Technician | \$60.00 |

| TOTAL TOOLING COST | | Plant A | Plant B |
|----------------------------|--------------------|---------|--------------------|
| TOTAL TOOLING COST | \$601,000 | | \$633,000 |
| TOTAL CAPITAL TOOLING COST | \$4,875,500 | | \$9,659,000 |
| TOTAL MISC. ITEMS COST | \$362,500 | | \$0 |
| GRAND TOTAL | \$6,089,000 | | \$6,089,000 |

9.2.5. Bins & Rack Computation

| No. | Item | Amount/ car | length (mm) | width (mm) | height (mm) | rack vol. (m ³) | rack no. | price per rack | parts / rack | rack / 4132 units | costs of racks |
|-----|---|----------------|----------------|---------------|----------------|-----------------------------------|-------------|-------------------|--------------|----------------------|-------------------|
| 1 | 7305-0900-137 Transition-FRT Frame Rail-LH-Inr | 1 | 803 | 223 | 344 | 0.062 | 3 | \$360 | 24 | 172 | \$61,920 |
| 2 | 7305-0900-138 Transition-FRT Frame Rail-RH-Inr | 1 | 803 | 223 | 344 | 0.062 | 3 | \$360 | 24 | 172 | \$61,920 |
| 3 | 7305-1100-220 REINF-Dash Transition Upr RH | 1 | 398 | 270 | 382 | 0.041 | 3 | \$360 | 36 | 115 | \$41,400 |
| 4 | 7305-1100-221 REINF-Dash Transition Upr LH | 1 | 398 | 270 | 382 | 0.041 | 3 | \$360 | 36 | 115 | \$41,400 |
| 5 | 7305-1110-101 Riser-RR Seat -CTR | 1 | 1,423 | 93 | 208 | 0.027 | 2 | \$530 | 31 | 133 | \$70,490 |
| 6 | 7305-1130-145 PNL-Cowl -Top | 1 | 1,577 | 135 | 327 | 0.070 | 1 | \$270 | 21 | 197 | \$53,190 |
| 7 | 7305-1130-147 PNL-Cowl -Supt | 1 | 1,578 | 216 | 280 | 0.096 | 3 | \$360 | 15 | 275 | \$99,000 |
| 8 | 7305-1200-209 Transition-FRT Frame Rail-LH-Otr | 1 | 854 | 191 | 309 | 0.050 | 2 | \$530 | 17 | 243 | \$128,790 |
| 9 | 7305-1200-210 Transition-FRT Frame Rail-RH-Otr | 1 | 854 | 191 | 309 | 0.050 | 2 | \$530 | 17 | 243 | \$128,790 |
| 10 | 7305-1300-155 PNL-A PLR INR-UPR-LH | 1 | 551 | 70 | 524 | 0.020 | 1 | \$270 | 33 | 125 | \$33,750 |
| 11 | 7305-1300-156 PNL-A PLR INR-UPR-RH | 1 | 551 | 70 | 524 | 0.020 | 1 | \$270 | 33 | 125 | \$33,750 |
| 12 | 7305-1300-165 Shock Tower-RR-LH | 1 | 486 | 302 | 325 | 0.048 | 3 | \$360 | 31 | 133 | \$47,880 |
| 13 | 7305-1300-166 Shock Tower-RR-RH | 1 | 486 | 302 | 325 | 0.048 | 3 | \$360 | 31 | 133 | \$47,880 |
| 14 | 7305-1310-151 Shock Tower-FRT-LH | 1 | 366 | 278 | 281 | 0.029 | 1 | \$270 | 24 | 172 | \$46,440 |
| 15 | 7305-1310-152 Shock Tower-FRT-RH | 1 | 366 | 278 | 281 | 0.029 | 1 | \$270 | 24 | 172 | \$46,440 |
| 16 | 7305-1310-161 PNL Wheelhouse-FRT-LH | 1 | 444 | 255 | 308 | 0.035 | 2 | \$530 | 24 | 172 | \$91,160 |
| 17 | 7305-1310-162 PNL Wheelhouse-FRT-RH | 1 | 444 | 255 | 308 | 0.035 | 2 | \$530 | 24 | 172 | \$91,160 |
| 18 | 7305-1400-153 PNL-A PLR INR-LWR-LH | 1 | 362 | 187 | 245 | 0.017 | 1 | \$270 | 41 | 101 | \$27,270 |
| 19 | 7305-1400-154 PNL-A PLR INR-LWR-RH | 1 | 362 | 187 | 245 | 0.017 | 1 | \$270 | 41 | 101 | \$27,270 |
| 20 | 7305-1500-157 PNL-Shotgun INR-LH | 1 | 885 | 53 | 369 | 0.017 | 1 | \$270 | 39 | 106 | \$28,620 |
| 21 | 7305-1500-158 PNL-Shotgun INR-RH | 1 | 885 | 53 | 369 | 0.017 | 1 | \$270 | 39 | 106 | \$28,620 |
| 22 | 7305-1500-197 REINF-BRKT A PLR INR-UPR-LH | 1 | 152 | 81 | 144 | 0.002 | 1 | \$270 | 382 | 11 | \$2,970 |
| 23 | 7305-1500-198 REINF-BRKT A PLR INR-UPR-RH | 1 | 152 | 81 | 144 | 0.002 | 1 | \$270 | 382 | 11 | \$2,970 |
| 24 | 7305-1500-227 REINF-BRKT A PLR INR-LWR-LH | 1 | 143 | 96 | 100 | 0.001 | 1 | \$270 | 492 | 8 | \$2,160 |
| 25 | 7305-1500-228 REINF-BRKT A PLR INR-LWR-RH | 1 | 143 | 96 | 100 | 0.001 | 1 | \$270 | 492 | 8 | \$2,160 |
| 26 | 7305-1600-149 REINF Dash-PNL | 1 | 1,464 | 306 | 611 | 0.274 | 7 | \$530 | 15 | 275 | \$145,750 |
| 27 | 7305-1600-183 PNL-Wheelhouse-RR Otr LH | 1 | 1,059 | 350 | 723 | 0.268 | 7 | \$530 | 15 | 275 | \$145,750 |
| 28 | 7305-1600-184 PNL-Wheelhouse-RR Otr RH | 1 | 1,059 | 350 | 723 | 0.268 | 7 | \$530 | 15 | 275 | \$145,750 |
| 29 | 7305-1900-159 PNL-Shotgun Close-Out-LH | 1 | 102 | 3 | 90 | 0.000 | 9 | \$50 | 611 | 7 | \$350 |
| 30 | 7305-1900-160 PNL-Shotgun Close-Out-RH | 1 | 102 | 3 | 90 | 0.000 | 9 | \$50 | 611 | 7 | \$350 |
| 31 | 7305-1930-169 PNL-Shotgun-Otr-LH | 1 | 866 | 301 | 369 | 0.096 | 3 | \$360 | 15 | 275 | \$99,000 |
| 32 | 7305-1930-170 PNL-Shotgun-Otr-RH | 1 | 866 | 301 | 369 | 0.096 | 3 | \$360 | 15 | 275 | \$99,000 |
| 33 | 7305-2100-104 PNL-RR HDR | 1 | 889 | 99 | 259 | 0.023 | 2 | \$530 | 37 | 112 | \$59,360 |
| 34 | 7305-2200-109 PNL-Roof | 1 | 2,031 | 186 | 1,370 | 0.517 | 5 | \$660 | 12 | 344 | \$227,040 |
| 35 | 7306-0810-123 Sill-Rocker Extrusion-LH | 1 | 1,563 | 132 | 178 | 0.037 | 7 | \$530 | 109 | 38 | \$20,140 |
| 36 | 7306-0820-124 Sill-Rocker Extrusion-RH | 1 | 1,563 | 132 | 178 | 0.037 | 7 | \$530 | 109 | 38 | \$20,140 |
| 37 | 7306-0830-124 BRKT-Floor Extrusion-FRT RH | 1 | 90 | 57 | 53 | 0.000 | 8 | \$65 | 157 | 26 | \$1,698 |
| 38 | 7306-0830-124 BRKT-Floor Extrusion-FRT LH | 1 | 90 | 57 | 53 | 0.000 | 8 | \$65 | 157 | 26 | \$1,698 |
| 39 | 7306-0830-124 BRKT-Floor Extrusion-RR LH | 1 | 90 | 57 | 53 | 0.000 | 8 | \$65 | 157 | 26 | \$1,698 |
| 40 | 7306-0830-124 BRKT-Floor Extrusion-RR RH | 1 | 90 | 57 | 53 | 0.000 | 8 | \$65 | 157 | 26 | \$1,698 |
| 41 | 7306-0830-125 Extrusion-Crossmeber Floor FRT LH | 1 | 603 | 51 | 51 | 0.002 | 8 | \$65 | 27 | 153 | \$9,991 |
| 42 | 7306-0830-125 Extrusion-Crossmeber Floor FRT RH | 1 | 603 | 51 | 51 | 0.002 | 8 | \$65 | 27 | 153 | \$9,991 |
| 43 | 7306-0830-125 Extrusion-Crossmeber Floor RR LH | 1 | 603 | 51 | 51 | 0.002 | 8 | \$65 | 27 | 153 | \$9,991 |
| 44 | 7306-0830-125 Extrusion-Crossmeber Floor RR RH | 1 | 603 | 51 | 51 | 0.002 | 8 | \$65 | 27 | 153 | \$9,991 |
| 45 | 7306-0830-126 Transition-Crossmember Floor FRT | 1 | 274 | 45 | 100 | 0.001 | 8 | \$65 | 35 | 118 | \$7,705 |
| 46 | 7306-0830-126 Transition-Crossmember Floor RR | 1 | 274 | 45 | 100 | 0.001 | 8 | \$65 | 35 | 118 | \$7,705 |
| 47 | 7306-0840-010 BRKT-Floor Extrusion-MID LH | 1 | 200 | 62 | 53 | 0.001 | 9 | \$50 | 21 | 197 | \$9,850 |
| 48 | 7306-0840-010 BRKT-Floor Extrusion-MID RH | 1 | 200 | 62 | 53 | 0.001 | 9 | \$50 | 21 | 197 | \$9,850 |
| 49 | 7306-0840-011 Extrusion-Crossmeber Floor MID LH | 1 | 602 | 51 | 152 | 0.005 | 3 | \$360 | 314 | 13 | \$4,680 |
| 50 | 7306-0840-011 Extrusion-Crossmeber Floor MID RH | 1 | 602 | 51 | 152 | 0.005 | 3 | \$360 | 314 | 13 | \$4,680 |

| No. | Item | Amount/ car | length (mm) | width (mm) | height (mm) | rack vol. (m ³) | rack no. | price per rack | parts / rack | rack / 4132 units | costs of racks |
|-----|--|----------------|----------------|---------------|----------------|-----------------------------------|-------------|-------------------|--------------|----------------------|-------------------|
| 51 | 7306-0840-012 Transition-Crossmember Floor MID | 1 | 276 | 146 | 100 | 0.004 | 3 | \$360 | 364 | 11 | \$3,960 |
| 52 | 7306-1000-175 Riser-RR Seat -LH | 1 | 768 | 94 | 148 | 0.011 | 4 | \$200 | 113 | 37 | \$7,400 |
| 53 | 7306-1000-176 Riser-RR Seat -RH | 1 | 768 | 94 | 148 | 0.011 | 4 | \$200 | 113 | 37 | \$7,400 |
| 54 | 7306-1110-103 REINF- FLR- RR Seat _LH | 1 | 350 | 44 | 97 | 0.001 | 4 | \$200 | 814 | 5 | \$1,000 |
| 55 | 7306-1110-104 REINF- FLR- RR Seat _RH | 1 | 350 | 44 | 97 | 0.001 | 4 | \$200 | 814 | 5 | \$1,000 |
| 56 | 7306-1130-143 PNL-Dash | 1 | 1,501 | 587 | 785 | 0.692 | 5 | \$660 | 9 | 459 | \$302,940 |
| 57 | 7306-1200-113 PNL-Floor-RR Seat | 1 | 1,396 | 68 | 815 | 0.077 | 3 | \$360 | 19 | 217 | \$78,120 |
| 58 | 7306-1910-189 PNL-A-OTR -UPR-LH | 1 | 1,255 | 60 | 511 | 0.039 | 4 | \$200 | 31 | 133 | \$26,600 |
| 59 | 7306-1910-190 PNL-A-OTR -UPR-RH | 1 | 1,255 | 60 | 511 | 0.039 | 4 | \$200 | 31 | 133 | \$26,600 |
| 60 | 7306-1910-195 C PLR OTR LH | 1 | 1,392 | 163 | 863 | 0.196 | 7 | \$530 | 20 | 207 | \$109,710 |
| 61 | 7306-1910-196 C PLR OTR RH | 1 | 1,392 | 163 | 863 | 0.196 | 7 | \$530 | 20 | 207 | \$109,710 |
| 62 | 7306-1913-001 PNL-B PLR QTR-LH | 1 | 1,306 | 69 | 197 | 0.018 | 4 | \$200 | 67 | 62 | \$12,400 |
| 63 | 7306-1920-191 PNL Roof Side Rail-OTR-LH | 1 | 963 | 129 | 143 | 0.018 | 4 | \$200 | 68 | 61 | \$12,200 |
| 64 | 7306-1920-192 PNL Roof Side Rail-OTR-RH | 1 | 963 | 129 | 143 | 0.018 | 4 | \$200 | 68 | 61 | \$12,200 |
| 65 | 7306-1924-002 PNL-B PLR QTR-RH | 1 | 1,306 | 69 | 197 | 0.018 | 4 | \$200 | 67 | 62 | \$12,400 |
| 66 | 7306-2000-171 PNL-Roof Side Rail INR-LH | 1 | 1,203 | 48 | 470 | 0.027 | 2 | \$530 | 54 | 77 | \$40,810 |
| 67 | 7306-2000-172 PNL-Roof Side Rail INR-RH | 1 | 1,203 | 48 | 470 | 0.027 | 3 | \$360 | 54 | 77 | \$27,720 |
| 68 | 7306-2000-215 PNL-Roof Side Rail INR RR-LH | 1 | 951 | 155 | 186 | 0.027 | 3 | \$360 | 54 | 77 | \$27,720 |
| 69 | 7306-2000-216 PNL-Roof Side Rail INR RR-RH | 1 | 951 | 155 | 186 | 0.027 | 3 | \$360 | 33 | 125 | \$45,000 |
| 70 | 7306-2100-101 PNL-FRT Header | 1 | 1,344 | 179 | 183 | 0.044 | 7 | \$530 | 91 | 45 | \$23,850 |
| 71 | 7306-2100-103 PNL Roof BOW | 1 | 1,164 | 59 | 162 | 0.011 | 4 | \$200 | 109 | 38 | \$7,600 |
| 72 | 7306-2300-185 PNL-Body Side-OTR-LH | 1 | 3,289 | 380 | 1,340 | 1.675 | 6 | \$790 | 5 | 826 | \$652,540 |
| 73 | 7306-2300-186 PNL-Body Side-OTR-RH | 1 | 3,289 | 380 | 1,340 | 1.675 | 6 | \$790 | 5 | 826 | \$652,540 |
| 74 | 7306-2300-187 PNL-RR QTR Closeout LH | 1 | 292 | 143 | 247 | 0.010 | 4 | \$200 | 116 | 36 | \$7,200 |
| 75 | 7306-2300-188 PNL-RR QTR Closeout RH | 1 | 292 | 143 | 247 | 0.010 | 4 | \$200 | 116 | 36 | \$7,200 |
| 76 | 7306-2300-189 Liftgate Flange Channel to Body OTR-LH | 1 | 610 | 79 | 96 | 0.005 | 4 | \$200 | 257 | 16 | \$3,200 |
| 77 | 7306-2300-190 Liftgate Flange Channel to Body OTR-RH | 1 | 610 | 79 | 96 | 0.005 | 4 | \$200 | 257 | 16 | \$3,200 |
| 78 | 7306-2300-191 PNL-RR Body Tailamp Closeout-LH | 1 | 173 | 97 | 127 | 0.002 | 1 | \$270 | 317 | 13 | \$3,510 |
| 79 | 7306-2300-192 PNL-RR Body Tailamp Closeout-RH | 1 | 173 | 97 | 127 | 0.002 | 1 | \$270 | 317 | 13 | \$3,510 |
| 80 | 7306-2400-229 Panel-Floor CTR LH | 1 | 1,252 | 710 | 60 | 0.053 | 7 | \$530 | 75 | 55 | \$29,150 |
| 81 | 7306-2400-230 Panel-Floor CTR RH | 1 | 1,252 | 710 | 60 | 0.053 | 7 | \$530 | 75 | 55 | \$29,150 |
| 82 | 7306-2400-231 Crossmember-RR Compt | 1 | 934 | 185 | 155 | 0.027 | 3 | \$360 | 55 | 75 | \$27,000 |
| 83 | 7307-0900-141 Transition-RR Frame Rail-LH-Inr | 1 | 1,006 | 182 | 290 | 0.053 | 7 | \$530 | 75 | 55 | \$29,150 |
| 84 | 7307-0900-142 Transition-RR Frame Rail-RH-Inr | 1 | 1,006 | 182 | 290 | 0.053 | 7 | \$530 | 75 | 55 | \$29,150 |
| 85 | 7307-1000-139 Rail-RR Frame-LH | 1 | 700 | 70 | 129 | 0.006 | 1 | \$270 | 108 | 38 | \$10,260 |
| 86 | 7307-1000-140 Rail-RR Frame-RH | 1 | 700 | 70 | 129 | 0.006 | 1 | \$270 | 108 | 38 | \$10,260 |
| 87 | 7307-1020-135 Rail-FRT Frame-LH | 1 | 574 | 70 | 133 | 0.005 | 1 | \$270 | 127 | 33 | \$8,910 |
| 88 | 7307-1020-136 Rail-FRT Frame-RH | 1 | 574 | 70 | 133 | 0.005 | 1 | \$270 | 127 | 33 | \$8,910 |
| 89 | 7307-1020-223 Plate-Frame Rail MTG-LH | 1 | 236 | 20 | 134 | 0.001 | 8 | \$65 | 69 | 60 | \$3,918 |
| 90 | 7307-1020-224 Plate-Frame Rail MTG-RH | 1 | 236 | 20 | 134 | 0.001 | 8 | \$65 | 69 | 60 | \$3,918 |
| 91 | 7307-1200-217 Transition-RR Frame Rail-LH-Otr | 1 | 1,006 | 198 | 273 | 0.054 | 7 | \$530 | 74 | 56 | \$29,680 |
| 92 | 7307-1200-218 Transition-RR Frame Rail-RH-Otr | 1 | 1,006 | 198 | 273 | 0.054 | 7 | \$530 | 74 | 56 | \$29,680 |
| 93 | 7307-1400-163 PNL-Wheelhouse-RR INR-LH | 1 | 1,378 | 240 | 697 | 0.231 | 7 | \$530 | 17 | 243 | \$128,790 |
| 94 | 7307-1400-164 PNL-Wheelhouse-RR INR-RH | 1 | 1,378 | 240 | 697 | 0.231 | 7 | \$530 | 17 | 243 | \$128,790 |
| 95 | 7307-1500-111 PNL-RR -End-Otr | 1 | 1,396 | 290 | 405 | 0.164 | 7 | \$530 | 24 | 172 | \$91,160 |
| 96 | 7307-1500-167 REINF-Shock Tower RR-LH | 1 | 277 | 126 | 262 | 0.009 | 4 | \$200 | 132 | 31 | \$6,200 |
| 97 | 7307-1500-168 REINF-Shock Tower RR-RH | 1 | 277 | 126 | 262 | 0.009 | 4 | \$200 | 132 | 31 | \$6,200 |
| 98 | 7307-1510-117 PNL-RR End | 1 | 1,495 | 367 | 398 | 0.218 | 5 | \$660 | 29 | 142 | \$93,720 |
| 99 | 7307-1600-213PNL-RR Compt to Wheelhouse INR-LH | 1 | 529 | 20 | 300 | 0.003 | 4 | \$200 | 373 | 11 | \$2,200 |
| 100 | 7307-2110-105 PNL-D PLR INR-LH | 1 | 984 | 89 | 326 | 0.028 | 3 | \$360 | 52 | 79 | \$28,440 |

| No. | Item | Amount/ car | length (mm) | width (mm) | height (mm) | rack vol. (m ³) | rack no. | price per rack | parts / rack | rack / 4132 units | costs of racks |
|-----|--------------------------------------|----------------|----------------|---------------|----------------|-----------------------------------|-------------|-------------------|---------------------|----------------------|--------------------|
| 101 | 7307-2110-106 PNL-D PLR INR-RH | 1 | 984 | 89 | 326 | 0.028 | 3 | \$360 | 52 | 79 | \$28,440 |
| 102 | 7307-2110-177 PNL-RR Otr INR UPR-RH | 1 | 516 | 220 | 331 | 0.038 | 3 | \$360 | 39 | 106 | \$38,160 |
| 103 | 7307-2110-179 PNL-Liftgate REINF LH | 1 | 653 | 151 | 364 | 0.036 | 3 | \$360 | 41 | 101 | \$36,360 |
| 104 | 7307-2110-180 PNL-Liftgate REINF RH | 1 | 653 | 151 | 364 | 0.036 | 3 | \$360 | 41 | 101 | \$36,360 |
| 105 | 7307-2120-178 PNL-RR Otr UPR INR -LH | 1 | 516 | 220 | 331 | 0.038 | 3 | \$360 | 39 | 106 | \$38,160 |
| 106 | B-PLR Reinforcement-LH | 1 | 450 | 73 | 139 | 0.005 | 4 | \$200 | 263 | 16 | \$3,200 |
| 107 | B-PLR Reinforcement-RH | 1 | 450 | 73 | 139 | 0.005 | 4 | \$200 | 263 | 16 | \$3,200 |
| 108 | BRACE-B-PLR UPR-LH | 1 | 354 | 165 | 224 | 0.013 | 3 | \$360 | 112 | 37 | \$13,320 |
| 109 | BRACE-B-PLR UPR-RH | 1 | 354 | 165 | 224 | 0.013 | 3 | \$360 | 112 | 37 | \$13,320 |
| 110 | BRKT INR B PLR LH | 1 | 193 | 89 | 129 | 0.002 | 1 | \$270 | 305 | 14 | \$3,780 |
| 111 | BRKT INR B PLR RH | 1 | 193 | 89 | 129 | 0.002 | 1 | \$270 | 305 | 14 | \$3,780 |
| 112 | PNL-B -PLR-INR-LH | 1 | 1,152 | 130 | 504 | 0.076 | 7 | \$530 | 53 | 78 | \$41,340 |
| 113 | PNL-B -PLR-INR-RH | 1 | 1,152 | 130 | 504 | 0.076 | 7 | \$530 | 53 | 78 | \$41,340 |
| 114 | PNL-Floor-RR Compt | 1 | 932 | 126 | 714 | 0.084 | 7 | \$530 | 48 | 86 | \$45,580 |
| 115 | PNL-RR Compt to Wheelhouse INR-RH | 1 | 529 | 20 | 300 | 0.003 | 1 | \$270 | 211 | 20 | \$5,400 |
| 116 | Rein-Shock Tower RR-LH | 1 | 348 | 129 | 277 | 0.012 | 4 | \$200 | 96 | 43 | \$8,600 |
| 117 | Rein-Shock Tower RR-RH | 1 | 348 | 129 | 277 | 0.012 | 4 | \$200 | 96 | 43 | \$8,600 |
| 118 | 7305-2400-209 Module FRT | 1 | 1,200 | 507 | 250 | 0.152 | 7 | \$530 | 26 | 159 | \$84,270 |
| 119 | 7305-2410-000 Bumper Frt | 1 | 1,630 | 300 | 300 | 0.147 | 7 | \$530 | 27 | 153 | \$81,090 |
| 120 | 7305-2430-000 Bumper RR | 1 | 1,630 | 300 | 300 | 0.147 | 7 | \$530 | 27 | 153 | \$81,090 |
| | | | | | | | | | total | 13593 | \$5,880,522 |
| | | | | | | | | | +contingency | 20% | \$7,056,626 |
| 121 | Fork Truck | | | | | | | | | | \$800,000 |
| 122 | Other | | | | | | | | | | \$200,000 |
| | | | | | | | | | TOTAL | | \$8,056,626 |

Racks

| rack no. | price \$ | rack | rack vol. (m ³) |
|-------------|-------------|------------------------------|-----------------------------------|
| 1 | \$270 | Big box, Polyethylen | 0.677 |
| 2 | \$530 | solid-walled stackable boxes | 0.840 |
| 3 | \$360 | foldable big box | 1.464 |
| 4 | \$200 | foldable big box | 1.200 |
| 5 | \$660 | Special box roof | 6.250 |
| 6 | \$790 | Special box sides | 8.750 |
| 7 | \$530 | Special box | 4.000 |
| 8 | \$65 | small load carrier 43 ltr. | 0.043 |
| 9 | \$50 | small load carrier 14 ltr. | 0.014 |







7.2 Appendix B: Competitive Set Study









Table B.a: Competitive set study







| ARB PHASE 2 HD | | | EPA Class | Euro NCAP Class | Phase 2 Class |
|---|-------------|---------------|---------------------|-----------------|--|
|  | | | | | |
| Lightweight Vehicle Study | | | Minicompact car | A segment | Micro cars |
| | | | Subcompact car | B segment | Mini cars |
| | | | Compact car | C segment | Small cars |
| | | | Midsize car | D segment | Midsize/midsize luxury cars |
| | | | Fullsize/ large car | E segment | Large/large luxury cars |
| | | | SUV | J segment | Small SUV Midsize/midsize luxury SUV Large SUV |
| | | | Small truck | - | Small pickup |
| | | | Standard truck | - | Large pickup |
| | | | Minivan | M segment | Minivan |
| mm | | | | | |
| in | | | | | |
| Length | 4800.6 | 189.0 | | | |
| Width | 1905.0 | 75.0 | | | |
| Height | 1595.1 | 62.8 | | | |
| Wheelbase | 2931.2 | 115.4 | | | |
| Front Track | 1630.7 | 64.2 | | | |
| Rear Track | 1636.8 | 64.4 | | | |
| mm ² | | | | | |
| in ² | | | | | |
| NHTSA Footprint | 4,787,229.1 | 7687.2 | | | |
| NHTSA Footprint (ft ²) | | 53.45 | | | |
| Shadow (ft ²) | | 98.44 | | | |
| Volume (ft ³) | | 447.95 | | | |
| Density (lbs./ft ³) | | 5.60 | | | |
| Specific Density (unitless) | | 1.00 | | | |
| Weight (lbs.) | | 2530.0 | | | |
| Engine Type | | | | | |
| Engine Displacement (liters) | | | | | |
| Power (horsepower) | | | | | |
| Torque (pound-feet) | | | | | |
| Power-to-weight-ratio (lb./hp) | | | | | |
| IIHS Frontal Offset TARGET | | GOOD (target) | | | |







| Definitions | |
|---------------------------|--|
| Footprint = | Length*0.5*(Front Track + Rear Track) |
| Shadow = | Length*Width |
| Volume = | <i>Sedans:</i> ((Wheelbase*Height) + ((Length - Wheelbase)*0.5 *Height))*Width <i>SUVs and Hatchbacks:</i> ((0.33*(Length - Wheelbase)*Height) + (Wheelbase*Height) + (0.67*(Length - Wheelbase)*0.5*Height)) <i>Trucks:</i> ((Bed Length*0.5*Height) + (0.5*(Length - Bed Length)*Height) + (0.5*(Length - Bed Length)*0.5*Height)) |
| Density = | Weight/Volume |
| Specific Density = | Density/ARB Phase 2 Density |





| Averages | | | | | | | |
|----------------------------------|-------|------|---|------------------------------|------|------|---|
| Density (lbs./ft ³): | | | ± | Specific Density (unitless): | | | ± |
| Micro cars: | 7.91 | 0 | | Micro cars: | 1.40 | 0 | |
| Mini Cars: | 8.23 | 0.43 | | Mini Cars: | 1.46 | 0.08 | |
| Small Cars: | 8.61 | 0.53 | | Small Cars: | 1.52 | 0.09 | |
| Midsize Cars: | 9.19 | 0.24 | | Midsize Cars: | 1.63 | 0.04 | |
| Midsize Luxury Cars: | 10.17 | 0.28 | | Midsize Luxury Cars: | 1.80 | 0.05 | |
| Large Cars: | 9.75 | 0.38 | | Large Cars: | 1.73 | 0.07 | |
| Large Luxury Cars: | 10.25 | 0.46 | | Large Luxury Cars: | 1.81 | 0.08 | |
| Small SUVs: | 8.56 | 0.37 | | Small SUVs: | 1.52 | 0.07 | |
| Midsize SUVs: | 9.10 | 0.42 | | Midsize SUVs: | 1.61 | 0.07 | |
| Midsize Luxury SUVs: | 9.56 | 0.21 | | Midsize Luxury SUVs: | 1.69 | 0.04 | |
| Large SUVs: | 9.19 | 0.39 | | Large SUVs: | 1.63 | 0.07 | |
| Small Pickups: | 10.09 | 0.46 | | Small Pickups: | 1.79 | 0.08 | |
| Large Pickups: | 9.66 | 0.37 | | Large Pickups: | 1.71 | 0.07 | |
| Minivans: | 8.17 | 0.17 | | Minivans: | 1.45 | 0.03 | |





| | MICRO CARS | | | | MINI CARS | | | | | | | |
|------------------------------------|---|-----------------|---|-----------------|---|-----------------|--|-----------------|---|-----------------|---|-----------------|
| |  | |  | |  | |  | |  | |  | |
| | mm | in | mm | in | mm | in | mm | in | mm | in | mm | in |
| Length | 2692.4 | 106.0 | 4114.8 | 162.0 | 4292.6 | 169.0 | 3723.6 | 146.6 | 3987.8 | 157.0 | 4409.4 | 173.6 |
| Width | 1549.4 | 61.0 | 1701.8 | 67.0 | 1701.8 | 67.0 | 1684.0 | 66.3 | 1701.8 | 67.0 | 1696.7 | 66.8 |
| Height | 1542.0 | 60.7 | 1524.0 | 60.0 | 1460.5 | 57.5 | 1409.7 | 55.5 | 1651.0 | 65.0 | 1473.2 | 58.0 |
| Wheelbase | 1879.6 | 74.0 | 2489.2 | 98.0 | 2540.0 | 100.0 | 2466.3 | 97.1 | 2529.8 | 99.6 | 2489.2 | 98.0 |
| Front Track | 1283.0 | 50.5 | 1491.0 | 58.7 | 1480.8 | 58.3 | 1458.0 | 57.4 | 1475.7 | 58.1 | 1465.6 | 57.7 |
| Rear Track | 1385.1 | 54.5 | 1475.7 | 58.1 | 1470.7 | 57.9 | 1465.6 | 57.8 | 1480.8 | 58.3 | 1465.6 | 57.7 |
| | mm ² | in ² | mm ² | in ² | mm ² | in ² | mm ² | in ² | mm ² | in ² | mm ² | in ² |
| NHTSA Footprint | 2,507,401.4 | 3886.5 | 3,692,379.7 | 5723.2 | 3,748,379.6 | 5810.0 | 3,605,221.8 | 5593.0 | 3,739,811.9 | 5796.7 | 3,648,121.7 | 5654.6 |
| NHTSA Footprint (ft ²) | 26.99 | | 39.74 | | 40.35 | | 38.84 | | 40.26 | | 39.27 | |
| Shadow (ft ⁴) | 44.90 | | 75.38 | | 78.63 | | 67.50 | | 73.05 | | 80.53 | |
| Volume (ft ³) | 227.17 | | 327.00 | | 299.86 | | 276.86 | | 347.22 | | 304.48 | |
| Density (lbs./ft ³) | 7.91 | | 7.79 | | 7.93 | | 8.89 | | 8.20 | | 8.33 | |
| Specific Density (unitless) | 1.40 | | 1.38 | | 1.40 | | 1.57 | | 1.45 | | 1.48 | |
| Weight (lbs.) | 1797.0 | | 2546.0 | | 2377.0 | | 2460.0 | | 2846.0 | | 2537.0 | |
| Engine Type | I-3 | | NA I-4 | | NA I-4 | | NA I-4 | | NA I-4 | | NA I-4 | |
| Engine Displacement (liters) | 1.0 | | 1.5 | | 1.5 | | 1.6 | | 1.8 | | 1.6 | |
| Power (horsepower) | 70 | | 117 | | 106 | | 121 | | 122 | | 120 | |
| Torque (pound-feet) | 68 | | 106 | | 103 | | 114 | | 127 | | 112 | |
| Power-to-weight-ratio (lb./hp) | 25.7 | | 21.8 | | 22.4 | | 20.3 | | 23.3 | | 21.1 | |
| IIHS Frontal Offset | GOOD | | GOOD | | GOOD | | GOOD | | GOOD | | GOOD | |







| | SMALL CARS | | | | | | | | | | | | | | | |
|------------------------------------|---|-----------------|---|-----------------|---|-----------------|---|-----------------|--|-----------------|---|-----------------|---|-----------------|---|-----------------|
| |  | |  | |  | |  | |  | |  | |  | |  | |
| | mm | in | mm | in | mm | in | mm | in | mm | in | mm | in | mm | in | mm | in |
| Length | 4495.8 | 177.0 | 4521.2 | 178.0 | 4572.0 | 180.0 | 4241.8 | 167.0 | 4414.5 | 173.8 | 4627.9 | 182.2 | 4358.6 | 171.6 | 4368.8 | 172.0 |
| Width | 1752.5 | 69.0 | 1778.0 | 70.0 | 1752.5 | 69.0 | 1752.5 | 69.0 | 1739.9 | 68.5 | 1778.0 | 70.0 | 1823.7 | 71.8 | 1701.8 | 67.0 |
| Height | 1435.1 | 56.5 | 1460.5 | 57.5 | 1491.0 | 58.7 | 1610.4 | 63.4 | 1478.7 | 58.1 | 1452.9 | 57.2 | 1465.6 | 57.7 | 1427.5 | 56.2 |
| Wheelbase | 2682.4 | 106.0 | 2641.6 | 104.0 | 2641.6 | 104.0 | 2590.8 | 102.0 | 2618.7 | 103.1 | 2651.8 | 104.4 | 2649.2 | 104.3 | 2550.2 | 100.4 |
| Front Track | 1498.6 | 59.0 | 1557.0 | 61.3 | 1530.0 | 60.2 | 1524.0 | 60.0 | 1496.1 | 58.9 | 1541.8 | 60.7 | 1554.5 | 61.2 | 1491.0 | 58.7 |
| Rear Track | 1529.1 | 60.2 | 1564.6 | 61.6 | 1530.0 | 60.2 | 1518.9 | 59.8 | 1496.1 | 58.9 | 1539.2 | 60.6 | 1544.3 | 60.8 | 1475.7 | 58.1 |
| | mm ² | in ² | mm ² | in ² | mm ² | in ² | mm ² | in ² | mm ² | in ² | mm ² | in ² | mm ² | in ² | mm ² | in ² |
| NHTSA Footprint | 4,075,862.8 | 6317.6 | 4,123,088.5 | 6390.8 | 4,041,648.0 | 6264.6 | 3,941,798.6 | 6109.8 | 3,917,792.2 | 6072.6 | 4,085,062.8 | 6331.9 | 4,104,701.5 | 6362.3 | 3,782,805.3 | 5863.4 |
| NHTSA Footprint (ft ²) | 43.87 | | 44.38 | | 43.50 | | 42.43 | | 42.17 | | 43.97 | | 44.18 | | 40.72 | |
| Shadow (ft ⁴) | 84.81 | | 86.53 | | 86.25 | | 80.02 | | 82.68 | | 88.57 | | 85.56 | | 80.03 | |
| Volume (ft ³) | 319.23 | | 328.43 | | 332.84 | | 367.65 | | 345.74 | | 332.04 | | 357.36 | | 322.53 | |
| Density (lbs./ft ³) | 8.62 | | 8.54 | | 9.25 | | 8.46 | | 9.06 | | 8.44 | | 8.17 | | 8.44 | |
| Specific Density (unitless) | 1.53 | | 1.51 | | 1.64 | | 1.50 | | 1.60 | | 1.50 | | 1.45 | | 1.49 | |
| Weight (lbs.) | 2751.0 | | 2805.0 | | 3080.0 | | 3109.0 | | 3133.0 | | 2804.0 | | 2920.0 | | 2721.0 | |
| Engine Type | NA I-4 | | NA I-4 | | NA I-4 | | NA I-4 | | NA H-4 | | NA I-4 | | NA I-4 | | Hybrid I-4 | |
| Engine Displacement (liters) | 1.8 | | 2.0 | | 2.0 | | 2.4 | | 2.5 | | 2.0 | | 2.0 | | 1.3 | |
| Power (horsepower) | 140 | | 156 | | 148 | | 158 | | 170 | | 115 | | 160 | | 98 | |
| Torque (pound-feet) | 128 | | 144 | | 146 | | 162 | | 170 | | 125 | | 146 | | 123 | |
| Power-to-weight-ratio (lb./hp) | 19.7 | | 18.0 | | 20.8 | | 19.7 | | 18.4 | | 24.4 | | 18.3 | | 27.8 | |
| IIHS Frontal Offset | GOOD | | GOOD | | GOOD | | GOOD | | GOOD | | GOOD | | GOOD (2011) | | GOOD | |





| | SMALL CARS | | | | | | | | | | | | | |
|------------------------------------|---|-----------------|---|-----------------|---|-----------------|---|-----------------|--|-----------------|---|-----------------|---|-----------------|
| |  | |  | |  | |  | |  | |  | |  | |
| | mm | in | mm | in | mm | in | mm | in | mm | in | mm | in | mm | in |
| Length | 4528.8 | 178.3 | 4597.4 | 181.0 | 4292.6 | 169.0 | 4470.4 | 176.0 | 4597.4 | 181.0 | 4419.6 | 174.0 | 4554.2 | 179.3 |
| Width | 1775.5 | 69.9 | 1752.6 | 69.0 | 1701.8 | 67.0 | 1752.6 | 69.0 | 1795.8 | 70.7 | 1752.6 | 69.0 | 1762.8 | 69.4 |
| Height | 1435.1 | 56.5 | 1470.7 | 57.9 | 1534.2 | 60.4 | 1491.0 | 58.7 | 1475.7 | 58.1 | 1534.2 | 60.4 | 1465.6 | 57.7 |
| Wheelbase | 2700.0 | 106.3 | 2641.6 | 104.0 | 2590.8 | 102.0 | 2692.4 | 106.0 | 2684.8 | 105.7 | 2641.6 | 104.0 | 2601.0 | 102.4 |
| Front Track | 1541.8 | 61.5 | 1534.2 | 60.4 | 1480.8 | 58.3 | 1513.8 | 59.6 | 1491.0 | 60.7 | 1498.6 | 59.0 | 1516.4 | 59.7 |
| Rear Track | 1541.8 | 62.0 | 1518.9 | 59.8 | 1485.9 | 58.5 | 1508.8 | 59.4 | 1475.7 | 61.3 | 1498.6 | 59.0 | 1521.5 | 59.9 |
| | mm ² | in ² | mm ² | in ² | mm ² | in ² | mm ² | in ² | mm ² | in ² | mm ² | in ² | mm ² | in ² |
| NHTSA Footprint | 4,162,836.8 | 6564.0 | 4,032,508.1 | 6250.4 | 3,843,089.1 | 5956.8 | 4,069,024.1 | 6307.0 | 3,982,495.3 | 6447.7 | 3,958,701.8 | 6136.0 | 3,950,650.2 | 6123.5 |
| NHTSA Footprint (ft ²) | 45.58 | | 43.41 | | 41.37 | | 43.80 | | 44.78 | | 42.61 | | 42.52 | |
| Shadow (ft ⁴) | 86.55 | | 86.73 | | 78.63 | | 84.33 | | 88.87 | | 83.38 | | 86.41 | |
| Volume (ft ³) | 325.23 | | 329.46 | | 343.22 | | 357.57 | | 340.76 | | 363.10 | | 375.30 | |
| Density (lbs./ft ³) | 8.90 | | 9.62 | | 8.02 | | 8.57 | | 9.10 | | 8.46 | | 7.46 | |
| Specific Density (unitless) | 1.58 | | 1.70 | | 1.42 | | 1.52 | | 1.61 | | 1.50 | | 1.32 | |
| Weight (lbs.) | 2895.0 | | 3170.0 | | 2751.0 | | 3064.0 | | 3102.0 | | 3073.0 | | 2800.0 | |
| Engine Type | NA I-4 | | NA I-4 | | NA I-4 | | Hybrid I-4 | | NA I-4 | | NA I-4 | | NA I-4 | |
| Engine Displacement (liters) | 1.8 | | 2.0 | | 1.8 | | 1.8 | | 1.8 | | 2.4 | | 1.8 | |
| Power (horsepower) | 148 | | 148 | | 122 | | 134 | | 138 | | 172 | | 132 | |
| Torque (pound-feet) | 131 | | 135 | | 127 | | 105 | | 123 | | 165 | | 128 | |
| Power-to-weight-ratio (lb./hp) | 19.6 | | 21.4 | | 22.5 | | 22.9 | | 22.5 | | 17.9 | | 21.2 | |
| IIHS Frontal Offset | GOOD (2010) | | GOOD | | GOOD | | GOOD | | GOOD | | GOOD | | GOOD | |







| MIDSIZE MODERATE CARS | | | | | | | | | | | | |
|------------------------------------|---|-----------------|---|-----------------|---|-----------------|--|-----------------|---|-----------------|---|-----------------|
| |  | |  | |  | |  | |  | |  | |
| | Chevrolet Malibu | | Dodge Avenger | | Ford Fusion | | Hyundai Sonata | | Toyota Camry | | Honda Accord Sedan | |
| | mm | in | mm | in | mm | in | mm | in | mm | in | mm | in |
| Length | 4871.7 | 191.8 | 4851.4 | 191.0 | 4826.0 | 190.0 | 4826.0 | 190.0 | 4800.6 | 189.0 | 4927.6 | 194.0 |
| Width | 1778.0 | 70.0 | 1854.2 | 73.0 | 1828.8 | 72.0 | 1828.8 | 72.0 | 1828.8 | 72.0 | 1854.2 | 73.0 |
| Height | 1447.8 | 57.0 | 1496.1 | 58.9 | 1445.3 | 56.9 | 1470.7 | 57.9 | 1470.7 | 57.9 | 1475.7 | 58.1 |
| Wheelbase | 2844.8 | 112.0 | 2768.6 | 109.0 | 2717.8 | 107.0 | 2794.0 | 110.0 | 2768.6 | 109.0 | 2794.0 | 110.0 |
| Front Track | 1513.8 | 59.6 | 1569.7 | 61.8 | 1567.2 | 61.7 | 1587.5 | 62.5 | 1574.8 | 62.0 | 1590.0 | 62.6 |
| Rear Track | 1524.0 | 60.0 | 1569.2 | 61.8 | 1557.0 | 61.3 | 1587.5 | 62.5 | 1564.6 | 61.6 | 1590.0 | 62.6 |
| | mm ² | in ² | mm ² | in ² | mm ² | in ² | mm ² | in ² | mm ² | in ² | mm ² | in ² |
| NHTSA Footprint | 4,321,023.6 | 6697.6 | 4,345,207.0 | 6735.1 | 4,245,475.4 | 6580.5 | 4,435,475.0 | 6875.0 | 4,345,926.8 | 6736.2 | 4,442,571.8 | 6886.0 |
| NHTSA Footprint (ft ²) | 46.51 | | 46.77 | | 45.70 | | 47.74 | | 46.78 | | 47.82 | |
| Shadow (ft ²) | 93.24 | | 96.83 | | 95.00 | | 95.00 | | 94.50 | | 98.35 | |
| Volume (ft ³) | 350.74 | | 373.24 | | 352.07 | | 361.88 | | 359.46 | | 373.08 | |
| Density (lbs./ft ³) | 9.24 | | 8.88 | | 9.61 | | 9.14 | | 9.19 | | 9.08 | |
| Specific Density (unitless) | 1.64 | | 1.57 | | 1.70 | | 1.62 | | 1.63 | | 1.61 | |
| Weight (lbs.) | 3242.0 | | 3314.0 | | 3384.0 | | 3309.0 | | 3303.0 | | 3386.0 | |
| Engine Type | NA I-4 | | NA I-4 | | NA I-4 | | NA I-4 | | NA I-4 | | NA I-4 | |
| Engine Displacement (liters) | 2.4 | | 2.4 | | 2.5 | | 2.4 | | 2.5 | | 2.4 | |
| Power (horsepower) | 169 | | 173 | | 175 | | 198 | | 169 | | 177 | |
| Torque (pound-feet) | 160 | | 166 | | 172 | | 184 | | 167 | | 161 | |
| Power-to-weight-ratio (lb./hp) | 19.2 | | 19.2 | | 19.3 | | 16.7 | | 19.5 | | 19.1 | |
| IIHS Frontal Offset | GOOD | | GOOD | | GOOD | | GOOD | | GOOD | | GOOD | |





| MIDSIZE LUXURY/NEAR LUXURY CARS | | | | | | | | | | |
|------------------------------------|---|-----------------|---|-----------------|---|-----------------|---|-----------------|---|-----------------|
| |  | |  | |  | |  | |  | |
| | Audi A4 | | Mercedes C-Class | | Lexus HS 250h | | Acura TL | | BMW 3-Series | |
| | mm | in | mm | in | mm | in | mm | in | mm | in |
| Length | 4699.0 | 185.0 | 4622.8 | 182.0 | 4699.0 | 185.0 | 4953.0 | 195.0 | 4521.2 | 178.0 |
| Width | 1828.8 | 72.0 | 1778.0 | 70.0 | 1778.0 | 70.0 | 1879.6 | 74.0 | 1828.8 | 72.0 |
| Height | 1427.5 | 56.2 | 1445.3 | 56.9 | 1506.2 | 59.3 | 1452.9 | 57.2 | 1419.9 | 55.9 |
| Wheelbase | 2809.2 | 110.6 | 2768.6 | 109.0 | 2700.0 | 106.3 | 2768.6 | 109.0 | 2768.6 | 109.0 |
| Front Track | 1564.6 | 61.6 | 1541.8 | 60.7 | 1534.2 | 60.4 | 1606.0 | 63.2 | 1501.1 | 59.1 |
| Rear Track | 1551.9 | 61.1 | 1544.3 | 60.8 | 1529.1 | 60.2 | 1620.0 | 63.8 | 1513.8 | 59.6 |
| | mm ² | in ² | mm ² | in ² | mm ² | in ² | mm ² | in ² | mm ² | in ² |
| NHTSA Footprint | 4,377,610.6 | 6785.3 | 4,272,088.2 | 6621.8 | 4,135,404.6 | 6409.9 | 4,465,751.8 | 6921.9 | 4,173,636.8 | 6469.2 |
| NHTSA Footprint (ft ²) | 47.12 | | 45.98 | | 44.51 | | 48.07 | | 44.92 | |
| Shadow (ft ²) | 92.50 | | 88.47 | | 89.93 | | 100.21 | | 89.00 | |
| Volume (ft ³) | 346.10 | | 335.37 | | 349.88 | | 372.33 | | 334.24 | |
| Density (lbs./ft ³) | 10.36 | | 9.86 | | 10.56 | | 10.02 | | 10.06 | |
| Specific Density (unitless) | 1.84 | | 1.75 | | 1.87 | | 1.77 | | 1.78 | |
| Weight (lbs.) | 3587.0 | | 3307.0 | | 3695.0 | | 3730.0 | | 3362.0 | |
| Engine Type | Turbo I-4 | | NA V-6 | | Hybrid, I-4 | | NA V-6 | | NA I-6 | |
| Engine Displacement (liters) | 2.0 | | 3.0 | | 2.4 | | 3.5 | | 3.0 | |
| Power (horsepower) | 211 | | 228 | | 187 | | 280 | | 230 | |
| Torque (pound-feet) | 258 | | 221 | | 138 | | 254 | | 200 | |
| Power-to-weight-ratio (lb./hp) | 17.0 | | 14.5 | | 19.8 | | 13.3 | | 14.6 | |
| IIHS Frontal Offset | GOOD | | GOOD | | GOOD | | GOOD | | GOOD | |







| LARGE FAMILY CARS | | | | | | | | | | |
|------------------------------------|---|-----------------|---|-----------------|--|-----------------|---|-----------------|---|-----------------|
| |  | |  | |  | |  | |  | |
| | Buick LaCrosse | | Ford Taurus | | Toyota Avalon | | Chevrolet Impala | | Dodge Charger | |
| | mm | in | mm | in | mm | in | mm | in | mm | in |
| Length | 5003.8 | 197.0 | 5156.2 | 203.0 | 5003.8 | 197.0 | 5080.0 | 200.0 | 5077.5 | 199.9 |
| Width | 1854.2 | 73.0 | 1930.4 | 76.0 | 1854.2 | 73.0 | 1854.2 | 73.0 | 1905.0 | 75.0 |
| Height | 1503.7 | 59.2 | 1541.8 | 60.7 | 1485.9 | 58.5 | 1491.0 | 58.7 | 1483.4 | 58.4 |
| Wheelbase | 2844.8 | 112.0 | 2867.7 | 112.9 | 2819.4 | 111.0 | 2819.4 | 111.0 | 3053.1 | 120.2 |
| Front Track | 1567.2 | 61.7 | 1658.6 | 65.3 | 1579.9 | 62.2 | 1585.0 | 62.4 | 1610.4 | 63.4 |
| Rear Track | 1574.8 | 62.0 | 1663.7 | 65.5 | 1564.6 | 61.6 | 1562.1 | 61.5 | 1620.5 | 63.8 |
| | mm ² | in ² | mm ² | in ² | mm ² | in ² | mm ² | in ² | mm ² | in ² |
| NHTSA Footprint | 4,469,152.4 | 6927.2 | 4,763,642.1 | 7383.7 | 4,432,829.8 | 6870.9 | 4,436,410.5 | 6876.5 | 4,932,067.6 | 7644.7 |
| NHTSA Footprint (ft ²) | 48.11 | | 51.28 | | 47.71 | | 47.75 | | 53.09 | |
| Shadow (ft ²) | 99.87 | | 107.14 | | 99.87 | | 101.39 | | 104.11 | |
| Volume (ft ³) | 386.39 | | 421.68 | | 380.59 | | 385.61 | | 405.68 | |
| Density (lbs./ft ³) | 10.15 | | 10.09 | | 9.43 | | 9.30 | | 9.76 | |
| Specific Density (unitless) | 1.80 | | 1.79 | | 1.67 | | 1.65 | | 1.73 | |
| Weight (lbs.) | 3922.0 | | 4253.0 | | 3589.0 | | 3585.0 | | 3961.0 | |
| Engine Type | NA I-4 | | NA V-6 | | NA V-6 | | NA V-6 | | NA V-6 | |
| Engine Displacement (liters) | 2.4 | | 3.5 | | 3.5 | | 3.5 | | 3.6 | |
| Power (horsepower) | 182 | | 263 | | 268 | | 211 | | 292 | |
| Torque (pound-feet) | 172 | | 249 | | 248 | | 216 | | 260 | |
| Power-to-weight-ratio (lb./hp) | 21.5 | | 16.2 | | 13.4 | | 17.0 | | 13.6 | |
| IIHS Frontal Offset | GOOD | | GOOD | | GOOD | | GOOD | | GOOD | |





| LARGE LUXURY CARS | | | | | | | | | | | | | | |
|------------------------------------|--|-----------------|--|-----------------|--|-----------------|--|-----------------|--|-----------------|--|-----------------|--|-----------------|
| |  | |  | |  | |  | |  | |  | |  | |
| | BMW 5-Series | | Cadillac CTS | | Hyundai Genesis | | Infiniti M37/M56 | | Lincoln MKS | | Mercedes E-Class | | Lexus GS | |
| | mm | in | mm | in | mm | in | mm | in | mm | in | mm | in | mm | in |
| Length | 4904.7 | 193.1 | 4876.8 | 192.0 | 4978.4 | 196.0 | 4953.0 | 195.0 | 5181.6 | 204.0 | 4876.8 | 192.0 | 4843.8 | 190.7 |
| Width | 1859.3 | 73.2 | 1854.2 | 73.0 | 1879.6 | 74.0 | 1854.2 | 73.0 | 1930.4 | 76.0 | 1854.2 | 73.0 | 1821.2 | 71.7 |
| Height | 1483.0 | 57.6 | 1419.9 | 55.9 | 1475.7 | 58.1 | 1501.1 | 59.1 | 1564.6 | 61.6 | 1470.7 | 57.9 | 1424.9 | 56.1 |
| Wheelbase | 2969.3 | 116.9 | 2870.2 | 113.0 | 2946.4 | 116.0 | 2895.6 | 114.0 | 2870.2 | 113.0 | 2870.2 | 113.0 | 2849.9 | 112.2 |
| Front Track | 1600.2 | 63.0 | 1569.7 | 61.8 | 1620.5 | 63.8 | 1574.8 | 62.0 | 1648.5 | 64.9 | 1600.2 | 63.0 | 1534.2 | 60.4 |
| Rear Track | 1628.1 | 64.1 | 1597.7 | 62.9 | 1635.8 | 64.4 | 1574.8 | 62.0 | 1653.5 | 65.1 | 1618.0 | 63.7 | 1599.2 | 60.6 |
| | mm ² | in ² | mm ² | in ² | mm ² | in ² | mm ² | in ² | mm ² | in ² | mm ² | in ² | mm ² | in ² |
| NHTSA Footprint | 4,792,890.4 | 7429.0 | 4,545,507.0 | 7045.6 | 4,797,151.7 | 7435.6 | 4,559,990.9 | 7068.0 | 4,738,700.2 | 7345.0 | 4,618,410.1 | 7158.6 | 4,379,410.6 | 6788.1 |
| NHTSA Footprint (ft ²) | 51.59 | | 48.93 | | 51.64 | | 49.08 | | 51.01 | | 49.71 | | 47.14 | |
| Shadow (ft ²) | 98.16 | | 97.33 | | 100.72 | | 98.85 | | 107.67 | | 97.33 | | 94.95 | |
| Volume (ft ³) | 378.20 | | 360.13 | | 388.14 | | 385.74 | | 429.42 | | 373.02 | | 352.54 | |
| Density (lbs./ft ³) | 10.08 | | 11.10 | | 9.91 | | 10.33 | | 9.69 | | 10.12 | | 10.51 | |
| Specific Density (unitless) | 1.79 | | 1.97 | | 1.75 | | 1.83 | | 1.72 | | 1.79 | | 1.86 | |
| Weight (lbs.) | 3814.0 | | 3997.0 | | 3845.0 | | 3986.0 | | 4160.0 | | 3774.0 | | 3704.0 | |
| Engine Type | I-6 | | NA V-6 | | NA V-6 | | NA V-7 | | NA V-6 | | NA V-6 | | NA V-6 | |
| Engine Displacement (liters) | 3.0 | | 3.0 | | 3.8 | | 3.7 | | 3.7 | | 3.5 | | 3.5 | |
| Power (horsepower) | 240 | | 270 | | 290 | | 330 | | 273 | | 268 | | 303 | |
| Torque (pound-feet) | 230 | | 223 | | 264 | | 270 | | 270 | | 258 | | 274 | |
| Power-to-weight-ratio (lb./hp) | 15.9 | | 14.8 | | 13.3 | | 12.1 | | 15.2 | | 14.1 | | 12.2 | |
| IIHS Frontal Offset | GOOD | | GOOD | | GOOD | | GOOD | | GOOD | | GOOD | | GOOD | |





| SMALL SUVS | | | | | | | | | | |
|------------------------------------|---|-----------------|---|-----------------|--|-----------------|---|-----------------|---|-----------------|
| |  | |  | |  | |  | |  | |
| | Honda Element | | Hyundai Tucson | | Jeep Patriot | | Volkswagen Tiguan | | Toyota RAV4 | |
| | mm | in | mm | in | mm | in | mm | in | mm | in |
| Length | 4292.6 | 169.0 | 4394.2 | 173.0 | 4419.6 | 174.0 | 4419.6 | 174.0 | 4620.3 | 181.9 |
| Width | 1828.8 | 72.0 | 1828.8 | 72.0 | 1752.6 | 69.0 | 1803.4 | 71.0 | 1816.1 | 71.5 |
| Height | 1788.2 | 70.4 | 1656.1 | 65.2 | 1668.8 | 65.7 | 1684.0 | 66.3 | 1684.0 | 66.3 |
| Wheelbase | 2565.4 | 101.0 | 2641.6 | 104.0 | 2641.6 | 104.0 | 2616.2 | 103.0 | 2659.4 | 104.7 |
| Front Track | 1577.3 | 62.1 | 1585.0 | 62.4 | 1518.9 | 59.8 | 1569.7 | 61.8 | 1559.6 | 61.4 |
| Rear Track | 1582.4 | 62.3 | 1585.0 | 62.4 | 1518.9 | 59.8 | 1572.3 | 61.9 | 1559.6 | 61.4 |
| | mm ² | in ² | mm ² | in ² | mm ² | in ² | mm ² | in ² | mm ² | in ² |
| NHTSA Footprint | 4,053,024.2 | 6282.2 | 4,186,830.3 | 6489.6 | 4,012,379.1 | 6219.2 | 4,110,024.0 | 6370.6 | 4,147,462.7 | 6428.6 |
| NHTSA Footprint (ft ²) | 43.63 | | 45.07 | | 43.19 | | 44.24 | | 44.64 | |
| Shadow (ft ²) | 84.50 | | 86.50 | | 83.38 | | 85.79 | | 90.32 | |
| Volume (ft ³) | 428.91 | | 407.19 | | 394.96 | | 409.21 | | 428.06 | |
| Density (lbs./ft ³) | 8.15 | | 8.24 | | 8.65 | | 9.07 | | 8.67 | |
| Specific Density (unitless) | 1.44 | | 1.46 | | 1.53 | | 1.61 | | 1.54 | |
| Weight (lbs.) | 3494.0 | | 3357.0 | | 3415.0 | | 3713.0 | | 3713.0 | |
| Engine Type | NA I-4 | | NA I-4 | | NA I-4 | | Turbo I-4 | | NA I-4 | |
| Engine Displacement (liters) | 2.4 | | 2.0 | | 2 | | 2.0 | | 2.5 | |
| Power (horsepower) | 166 | | 165 | | 158 | | 200 | | 179 | |
| Torque (pound-feet) | 161 | | 146 | | 141 | | 207 | | 172 | |
| Power-to-weight-ratio (lb./hp) | 21.0 | | 20.3 | | 21.6 | | 18.6 | | 20.7 | |
| IIHS Frontal Offset | GOOD | | GOOD | | GOOD | | GOOD | | GOOD | |

| MIDSIZE SUV UNIBODY | | | | | | | | | | | | |
|------------------------------------|--|-----------------|--|-----------------|--|-----------------|---|-----------------|--|-----------------|--|-----------------|
| |  | |  | |  | |  | |  | |  | |
| | Chevrolet Equinox | | Dodge Journey | | Ford Explorer | | Subaru Tribeca | | Toyota Venza | | Jeep Grand Cherokee | |
| | mm | in | mm | in | mm | in | mm | in | mm | in | mm | in |
| Length | 4775.2 | 188.0 | 4876.8 | 192.0 | 5006.3 | 197.1 | 4826.0 | 190.0 | 4800.6 | 189.0 | 4826.0 | 190.0 |
| Width | 1828.8 | 72.0 | 1828.8 | 72.0 | 2004.1 | 78.9 | 1879.6 | 74.0 | 1905.0 | 75.0 | 1930.4 | 76.0 |
| Height | 1684.0 | 66.3 | 1691.6 | 66.6 | 1788.2 | 70.4 | 1686.6 | 66.4 | 1610.4 | 63.4 | 1729.7 | 68.1 |
| Wheelbase | 2844.8 | 112.0 | 2895.6 | 114.0 | 2860.0 | 112.6 | 2743.2 | 108.0 | 2768.6 | 109.0 | 2921.0 | 115.0 |
| Front Track | 1587.5 | 62.5 | 1569.7 | 61.8 | 1701.8 | 67.0 | 1579.9 | 62.2 | 1630.7 | 64.2 | 1623.1 | 63.9 |
| Rear Track | 1569.7 | 61.8 | 1582.4 | 62.3 | 1701.8 | 67.0 | 1577.3 | 62.1 | 1635.8 | 64.4 | 1628.1 | 64.1 |
| | mm ² | in ² | mm ² | in ² | mm ² | in ² | mm ² | in ² | mm ² | in ² | mm ² | in ² |
| NHTSA Footprint | 4,490,829.7 | 6960.8 | 4,563,668.3 | 7073.7 | 4,867,216.1 | 7544.2 | 4,330,443.0 | 6712.2 | 4,521,732.9 | 7008.7 | 4,748,377.6 | 7360.0 |
| NHTSA Footprint (ft ²) | 48.34 | | 49.12 | | 52.39 | | 46.61 | | 48.67 | | 51.11 | |
| Shadow (ft ²) | 94.00 | | 96.00 | | 107.99 | | 97.64 | | 98.44 | | 100.28 | |
| Volume (ft ³) | 449.02 | | 460.29 | | 542.57 | | 462.16 | | 446.33 | | 493.82 | |
| Density (lbs./ft ³) | 9.33 | | 9.32 | | 8.31 | | 9.00 | | 9.16 | | 9.49 | |
| Specific Density (unitless) | 1.65 | | 1.65 | | 1.47 | | 1.59 | | 1.62 | | 1.68 | |
| Weight (lbs.) | 4189.0 | | 4292.0 | | 4509.0 | | 4158.0 | | 4090.0 | | 4687.0 | |
| Engine Type | NA I-4 | | NA I-4 | | NA V-6 | | NA H-6 | | NA I-4 | | NA V-6 | |
| Engine Displacement (liters) | 2.4 | | 2.4 | | 3.5 | | 3.6 | | 2.7 | | 3.6 | |
| Power (horsepower) | 182 | | 173 | | 283 | | 256 | | 182 | | 290 | |
| Torque (pound-feet) | 172 | | 166 | | 252 | | 247 | | 182 | | 260 | |
| Power-to-weight-ratio (lb./hp) | 23.0 | | 24.8 | | 15.9 | | 16.2 | | 22.5 | | 16.2 | |
| IIHS Frontal Offset | GOOD | | GOOD | | GOOD | | GOOD | | GOOD | | GOOD | |

| MIDSIZE LUXURY SUVs | | | | | | | | | | |
|------------------------------------|---|-----------------|---|-----------------|--|-----------------|---|-----------------|---|-----------------|
| |  | |  | |  | |  | |  | |
| | Audi Q5 | | Cadillac SRX | | Lexus RX | | Volvo XC90 | | BMW X5 | |
| | mm | in | mm | in | mm | in | mm | in | mm | in |
| Length | 4622.8 | 182.0 | 4826.0 | 190.0 | 4775.2 | 188.0 | 4800.6 | 189.0 | 4851.4 | 191.0 |
| Width | 1879.6 | 74.0 | 1905.0 | 75.0 | 1879.6 | 74.0 | 1905.0 | 75.0 | 1930.4 | 76.0 |
| Height | 1653.5 | 65.1 | 1668.8 | 65.7 | 1719.6 | 67.7 | 1783.1 | 70.2 | 1775.5 | 69.9 |
| Wheelbase | 2819.4 | 111.0 | 2819.4 | 111.0 | 2743.2 | 108.0 | 2844.8 | 112.0 | 2921.0 | 115.0 |
| Front Track | 1618.0 | 63.7 | 1620.5 | 63.8 | 1630.7 | 64.2 | 1633.2 | 64.3 | 1643.4 | 64.7 |
| Rear Track | 1612.9 | 63.5 | 1610.4 | 63.4 | 1620.5 | 63.8 | 1623.1 | 63.9 | 1651.0 | 65.0 |
| | mm ² | in ² | mm ² | in ² | mm ² | in ² | mm ² | in ² | mm ² | in ² |
| NHTSA Footprint | 4,554,571.5 | 7059.6 | 4,554,571.5 | 7059.6 | 4,459,345.9 | 6912.0 | 4,631,732.7 | 7179.2 | 4,811,442.0 | 7457.8 |
| NHTSA Footprint (ft ²) | 49.03 | | 49.03 | | 48.00 | | 49.86 | | 51.79 | |
| Shadow (ft ²) | 93.53 | | 98.96 | | 96.61 | | 98.44 | | 100.81 | |
| Volume (ft ³) | 441.08 | | 466.33 | | 467.35 | | 497.27 | | 508.92 | |
| Density (lbs./ft ³) | 9.70 | | 9.68 | | 9.40 | | 9.28 | | 9.75 | |
| Specific Density (unitless) | 1.72 | | 1.71 | | 1.66 | | 1.64 | | 1.73 | |
| Weight (lbs.) | 4277.0 | | 4513.0 | | 4392.0 | | 4617.0 | | 4960.0 | |
| Engine Type | Turbo I-4 | | NA V-6 | | NA V-6 | | NA I-6 | | Turbo I-6 | |
| Engine Displacement (liters) | 2 | | 3.0 | | 3.5 | | 3.2 | | 3.0 | |
| Power (horsepower) | 211 | | 265 | | 275 | | 240 | | 300 | |
| Torque (pound-feet) | 258 | | 223 | | 257 | | 236 | | 300 | |
| Power-to-weight-ratio (lb./hp) | 20.3 | | 17.0 | | 16.0 | | 19.2 | | 16.5 | |
| IIHS Frontal Offset | GOOD | | GOOD | | GOOD | | GOOD | | GOOD | |

| LARGE SUVs - BODY ON FRAME | | | | | | | | | | | LARGE SUVs - UNIBODY | | | | | |
|------------------------------------|--|-----------------|--|-----------------|--|-----------------|---|-----------------|--|-----------------|--|-----------------|--|--|--|--|
| |  | |  | |  | |  | |  | |  | | | | | |
| | Audi Q7 | | Chevrolet Tahoe | | Ford Expedition | | GMC Acadia | | Mercedes R-Class | | Ford Flex | | | | | |
| | mm | in | mm | in | mm | in | mm | in | mm | in | mm | in | | | | |
| Length | 5080.0 | 200.0 | 5649.0 | 222.0 | 5245.1 | 206.5 | 5105.4 | 201.0 | 5156.2 | 203.0 | 5130.8 | 202.0 | | | | |
| Width | 1981.2 | 78.0 | 2009.1 | 79.0 | 2001.5 | 78.8 | 1981.2 | 78.0 | 1930.4 | 76.0 | 2032.0 | 80.0 | | | | |
| Height | 1737.4 | 68.4 | 1950.7 | 76.9 | 1960.9 | 77.2 | 1775.5 | 69.9 | 1922.8 | 75.7 | 1727.2 | 68.0 | | | | |
| Wheelbase | 2997.2 | 118.0 | 3302.0 | 116.0 | 3022.6 | 119.0 | 3022.6 | 119.0 | 3225.8 | 127.0 | 2997.2 | 118.0 | | | | |
| Front Track | 1651.0 | 65.0 | 1724.7 | 67.9 | 1704.3 | 67.1 | 1704.3 | 67.1 | 1663.7 | 65.5 | 1661.2 | 65.4 | | | | |
| Rear Track | 1676.4 | 66.0 | 1755.1 | 69.1 | 1704.3 | 67.1 | 1704.3 | 67.1 | 1658.6 | 65.3 | 1661.2 | 65.4 | | | | |
| | mm ² | in ² | mm ² | in ² | mm ² | in ² | mm ² | in ² | mm ² | in ² | mm ² | in ² | | | | |
| NHTSA Footprint | 4,986,441.6 | 7729.0 | 5,745,149.8 | 8905.0 | 5,151,538.1 | 7984.9 | 5,151,538.1 | 7984.9 | 5,358,569.9 | 8305.8 | 4,978,828.8 | 7717.2 | | | | |
| NHTSA Footprint (ft ²) | 53.67 | | 61.84 | | 55.45 | | 55.45 | | 57.68 | | 53.59 | | | | | |
| Shadow (ft ²) | 108.33 | | 110.82 | | 113.00 | | 108.88 | | 107.14 | | 112.22 | | | | | |
| Volume (ft ³) | 532.69 | | 608.88 | | 623.78 | | 547.52 | | 591.10 | | 547.34 | | | | | |
| Density (lbs./ft ³) | 9.66 | | 9.34 | | 9.37 | | 8.87 | | 8.76 | | 8.72 | | | | | |
| Specific Density (unitless) | 1.71 | | 1.65 | | 1.66 | | 1.57 | | 1.55 | | 1.54 | | | | | |
| Weight (lbs.) | 5148.0 | | 5684.0 | | 5847.0 | | 4857.0 | | 5176.0 | | 4773.0 | | | | | |
| Engine Type | Supercharged V-6 | | NA V-8 | | NA V-8 | | NA V-6 | | NA V-6 | | NA V-6 | | | | | |
| Engine Displacement (liters) | 3.0 | | 5.3 | | 5.4 | | 3.6 | | 3.5 | | 3.5 | | | | | |
| Power (horsepower) | 272 | | 320 | | 310 | | 288 | | 268 | | 262 | | | | | |
| Torque (pound-feet) | 295 | | 335 | | 365 | | 270 | | 258 | | 248 | | | | | |
| Power-to-weight-ratio (lb./hp) | 18.9 | | 17.8 | | 18.9 | | 16.9 | | 19.3 | | 18.2 | | | | | |
| IIHS Frontal Offset | GOOD | | UNTESTED | | UNTESTED | | GOOD | | GOOD | | GOOD | | | | | |

| | MINIVANS | | | | | | | |
|------------------------------------|---|-----------------|---|-----------------|--|-----------------|---|-----------------|
| |  | |  | |  | |  | |
| | Toyota Sienna | | Dodge Grand Caravan | | Honda Odyssey | | Kia Sedona | |
| | mm | in | mm | in | mm | in | mm | in |
| Length | 5085.1 | 200.2 | 5156.2 | 203.0 | 5153.7 | 202.9 | 5130.8 | 202.0 |
| Width | 1983.7 | 78.1 | 1955.8 | 77.0 | 2011.7 | 79.2 | 1981.2 | 78.0 |
| Height | 1765.3 | 69.5 | 1750.1 | 68.9 | 1737.4 | 68.4 | 1760.2 | 69.3 |
| Wheelbase | 3030.2 | 119.3 | 3073.4 | 121.0 | 2999.7 | 118.1 | 3022.6 | 119.0 |
| Front Track | 1719.6 | 67.7 | 1663.7 | 65.5 | 1729.7 | 68.1 | 1684.0 | 66.3 |
| Rear Track | 1719.6 | 67.7 | 1645.9 | 64.8 | 1732.3 | 68.2 | 1684.0 | 66.3 |
| | mm ² | in ² | mm ² | in ² | mm ² | in ² | mm ² | in ² |
| NHTSA Footprint | 5,210,705.7 | 8076.6 | 5,085,893.1 | 7883.2 | 5,192,579.9 | 8048.5 | 5,090,118.9 | 7889.7 |
| NHTSA Footprint (ft ²) | 56.09 | | 54.74 | | 55.89 | | 54.79 | |
| Shadow (ft ²) | 108.58 | | 108.55 | | 111.60 | | 109.42 | |
| Volume (ft3) | 543.73 | | 538.91 | | 547.03 | | 544.90 | |
| Density (lbs./ft3) | 7.99 | | 8.27 | | 8.07 | | 8.36 | |
| Specific Density (unitless) | 1.41 | | 1.46 | | 1.43 | | 1.48 | |
| Weight (lbs.) | 4342.0 | | 4456.0 | | 4412.0 | | 4555.0 | |
| Engine Type | NA I-4 | | NA V-6 | | NA V-6 | | NA V-6 | |
| Engine Displacement (liters) | 2.7 | | 3.6 | | 3.5 | | 3.5 | |
| Power (horsepower) | 187 | | 283 | | 248 | | 271 | |
| Torque (pound-feet) | 186 | | 260 | | 250 | | 248 | |
| Power-to-weight-ratio (lb./hp) | 23.2 | | 15.7 | | 17.8 | | 16.8 | |
| IIHS Frontal Offset | GOOD | | GOOD | | GOOD | | GOOD | |

| | SMALL TRUCKS BODY ON FRAME | | | | | | UNIBODY | | | | | |
|------------------------------------|---|-----------------|---|-----------------|---|-----------------|---|----------------------------------|--------------------|-----------------|-----------------|-----------------|
| |  | |  | |  | |  | | | | | |
| | Nissan Frontier | | Toyota Tacoma | | Ford Ranger - Ext. Cab | | Ram Dakota Crew-cab | Chevrolet Colorado - Ext.-cab | Honda Ridgeline | | | |
| | mm | in | mm | in | mm | in | mm | in | | | | |
| Length | 5232.4 | 206.0 | 5613.4 | 221.0 | 5156.2 | 203.0 | 5562.6 | 219.0 | 5257.8 | 207.0 | 5257.8 | 207.0 |
| Width | 1854.2 | 73.0 | 1905.0 | 75.0 | 1752.6 | 69.0 | 1879.6 | 74.0 | 1752.6 | 69.0 | 1976.1 | 77.8 |
| Height | 1745.0 | 68.7 | 1671.3 | 65.8 | 1719.6 | 67.7 | 1742.4 | 68.6 | 1648.5 | 64.9 | 1785.6 | 70.3 |
| Wheelbase | 3200.4 | 126.0 | 3581.4 | 141.0 | 3200.4 | 126.0 | 3327.4 | 131.0 | 3200.4 | 126.0 | 3098.8 | 122.0 |
| Front Track | 1569.7 | 61.8 | 1549.4 | 61.0 | 1485.9 | 58.5 | 1595.1 | 62.8 | 1460.5 | 57.5 | 1704.3 | 67.1 |
| Rear Track | 1569.7 | 61.8 | 1549.4 | 61.0 | 1455.4 | 57.3 | 1597.7 | 62.9 | 1460.5 | 57.5 | 1699.3 | 66.9 |
| | mm ² | in ² | mm ² | in ² | mm ² | in ² | mm ² | in ² | mm ² | in ² | mm ² | in ² |
| NHTSA Footprint | 5,023,731.9 | 7786.8 | 5,549,021.2 | 8601.0 | 4,706,700.3 | 7295.4 | 5,311,828.1 | 8233.4 | 4,674,184.2 | 7245.0 | 5,273,537.8 | 8174.0 |
| NHTSA Footprint (ft ²) | 54.08 | | 59.73 | | 50.66 | | 57.18 | | 50.31 | | 56.76 | |
| Shadow (ft ²) | 104.43 | | 115.10 | | 97.27 | | 112.54 | | 99.19 | | 111.84 | |
| Volume (ft3) | 396.16 | | 421.96 | | 362.92 | | 429.64 | | 355.68 | | 434.41 | |
| Density (lbs./ft3) | 10.66 | | 9.37 | | 9.76 | | 10.17 | | 10.21 | | 10.37 | |
| Specific Density (unitless) | 1.89 | | 1.66 | | 1.73 | | 1.80 | | 1.81 | | 1.84 | |
| Weight (lbs.) | 4222.0 | | 3953.0 | | 3541.0 | | 4370.0 | | 3631.0 | | 4504.0 | |
| Engine Type | NA I-4 | | NA I-4 | | NA I-4 | | NA V-6 | | NA I-4 | | NA V-6 | |
| Engine Displacement (liters) | 2.5 | | 2.7 | | 2.3 | | 3.7 | | 2.9 | | 3.5 | |
| Power (horsepower) | 152 | | 159 | | 143 | | 210 | | 185 | | 250 | |
| Torque (pound-feet) | 171 | | 180 | | 154 | | 235 | | 190 | | 247 | |
| Power-to-weight-ratio (lb./hp) | 27.8 | | 24.9 | | 24.8 | | 20.8 | | 19.6 | | 18.0 | |
| IIHS Frontal Offset | GOOD | | GOOD | | ACCEPTABLE | | GOOD | | GOOD | | GOOD | |





| FULLSIZE TRUCKS | | | | | | | | | | |
|------------------------------------|---|-----------------|---|-----------------|--|-----------------|---|-----------------|---|-----------------|
| |  | |  | |  | |  | |  | |
| | Ram 1500 | | Toyota Tundra | | Ford F-150 | | Nissan Titan | | Chevrolet Silverado | |
| | mm | in | mm | in | mm | in | mm | in | mm | in |
| Length | 5763.3 | 226.9 | 5809.0 | 228.7 | 5887.7 | 231.8 | 5704.8 | 224.6 | 5847.1 | 230.2 |
| Width | 2016.8 | 79.4 | 2029.5 | 79.9 | 2011.7 | 79.2 | 2019.3 | 79.5 | 2029.5 | 79.9 |
| Height | 1861.8 | 73.3 | 1920.2 | 75.6 | 1930.4 | 76.0 | 1945.6 | 76.6 | 1877.1 | 73.9 |
| Wheelbase | 3568.7 | 140.5 | 3700.8 | 145.7 | 3670.3 | 144.5 | 3550.9 | 139.8 | 3644.9 | 143.5 |
| Front Track | 1727.2 | 68.0 | 1724.7 | 67.9 | 1701.8 | 67.0 | 1724.7 | 67.9 | 1729.7 | 68.1 |
| Rear Track | 1714.5 | 67.5 | 1724.7 | 67.9 | 1701.8 | 67.0 | 1724.7 | 67.9 | 1701.8 | 67.0 |
| | mm ² | in ² | mm ² | in ² | mm ² | in ² | mm ² | in ² | mm ² | in ² |
| NHTSA Footprint | 6,141,197.4 | 9518.9 | 6,382,587.2 | 9893.0 | 6,246,116.5 | 9681.5 | 6,124,129.7 | 9492.4 | 6,253,810.1 | 9693.4 |
| NHTSA Footprint (ft ²) | 66.10 | | 68.70 | | 67.23 | | 65.92 | | 67.32 | |
| Shadow (ft ²) | 125.11 | | 126.90 | | 127.49 | | 124.00 | | 127.73 | |
| Volume (ft ³) | 512.54 | | 536.67 | | 542.88 | | 530.21 | | 528.44 | |
| Density (lbs./ft ³) | 9.13 | | 9.78 | | 8.83 | | 9.41 | | 9.28 | |
| Specific Density (unitless) | 1.62 | | 1.73 | | 1.56 | | 1.67 | | 1.64 | |
| Weight (lbs.) | 4677.0 | | 5250.0 | | 4795.0 | | 4987.0 | | 4904.0 | |
| Engine Type | NA V-6 | | NA V-6 | | NA V-6 | | NA V-8 | | NA V-6 | |
| Engine Displacement (liters) | 3.7 | | 4.0 | | 3.7 | | 5.6 | | 4.3 | |
| Power (horsepower) | 210 | | 270 | | 302 | | 317 | | 195 | |
| Torque (pound-feet) | 235 | | 278 | | 278 | | 385 | | 260 | |
| Power-to-weight-ratio (lb./hp) | 22.3 | | 19.4 | | 15.9 | | 15.7 | | 25.1 | |
| IIHS Frontal Offset | GOOD | | GOOD | | GOOD | | GOOD | | GOOD | |

Figure B.a below shows that the vehicle data collected for this analysis falls within the data range collected independently by the IIHS. The data used for this analysis is displayed in red while the IIHS' data is displayed in grey and blue.

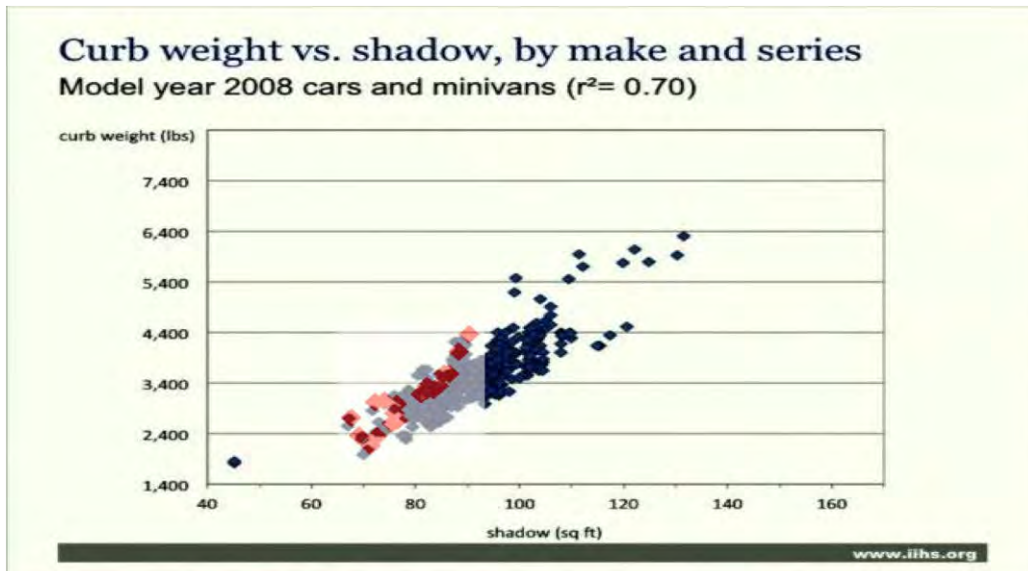

Figure B.a: IIHS and Lotus vehicle data, curb weight as a function of shadow

7.3 Appendix C: 2009 Toyota Venza and Phase 2 HD Piece Costs

Table C.a below shows the piece costs of the Toyota Venza per Intellicosting.

Table C.a: Toyota Venza piece costs

| | Material(\$) | Direct(\$) | Variable(\$) | Fixed (\$) | SG&A (\$) | Profit (\$) | Total Cost (\$) |
|---|--------------|------------|--------------|------------|-----------|-------------|-----------------|
| 2: BIW - Panel | | | | | | | |
| Roof (Item #46) | | | | | | | |
| | \$30.169 | \$0.352 | \$1.295 | \$1.126 | \$1.647 | \$2.635 | \$37.906 |
| 5: BIW - BIW - Panel - Panel | | | | | | | |
| Rear End, Outer (Item #20) | | | | | | | |
| | \$9.160 | \$0.169 | \$0.647 | \$0.658 | \$0.532 | \$0.851 | \$12.223 |
| 6: BIW - BIW - Panel - Bracket | | | | | | | |
| Mounting, Rear Bumper Cover, Lower, Lh (Item #143) | | | | | | | |
| | \$0.292 | \$0.023 | \$0.060 | \$0.044 | \$0.021 | \$0.034 | \$0.481 |
| 7: BIW - BIW - Panel - Bracket | | | | | | | |
| Mounting, Rear Bumper Cover, Lower, Rh (Item #143) | | | | | | | |
| | \$0.292 | \$0.023 | \$0.060 | \$0.044 | \$0.021 | \$0.034 | \$0.481 |
| 8: BIW - BIW - Panel - Bracket | | | | | | | |
| Mounting, Rear Bumper Cover, Upper, Lh (Item #144) | | | | | | | |
| | \$0.190 | \$0.015 | \$0.041 | \$0.030 | \$0.014 | \$0.022 | \$0.317 |
| 9: BIW - BIW - Panel - Bracket | | | | | | | |
| Mounting, Rear Bumper Cover, Upper, Rh (Item #144) | | | | | | | |
| | \$0.190 | \$0.015 | \$0.041 | \$0.030 | \$0.014 | \$0.022 | \$0.317 |
| 11: BIW - BIW - Panel - Support - Support | | | | | | | |
| Crash, Low Speed, Rear, Inboard, Lh (Item # 26a) | | | | | | | |
| | \$1.568 | \$0.109 | \$0.219 | \$0.084 | \$0.099 | \$0.159 | \$2.273 |
| 13: BIW - BIW - Panel - Support - Support - Support | | | | | | | |



LOTUS ARB LWV PROGRAM

| | | | | | | | | |
|---|--|---------|---------|---------|---------|---------|---------|---------|
| Crash, Low Speed, Rear, Outboard, Lh (Item # 26b) | | | | | | | | |
| | | \$1.468 | \$0.109 | \$0.219 | \$0.084 | \$0.094 | \$0.151 | \$2.158 |
| 17: BIW - BIW - Panel - Support - Support | | | | | | | | |
| Crash, Low Speed, Rear, Inboard, Rh (Item # 26a) | | | | | | | | |
| | | \$1.568 | \$0.109 | \$0.219 | \$0.084 | \$0.099 | \$0.159 | \$2.273 |
| 19: BIW - BIW - Panel - Support - Support - Support | | | | | | | | |
| Crash, Low Speed, Rear, Outboard, Rh (Item # 26b) | | | | | | | | |
| | | \$1.468 | \$0.109 | \$0.219 | \$0.084 | \$0.094 | \$0.151 | \$2.158 |
| 24: BIW - BIW - BIW - Header - Panel | | | | | | | | |
| Header, Front, Upper (Item #47) | | | | | | | | |
| | | \$1.412 | \$0.083 | \$0.166 | \$0.091 | \$0.088 | \$0.140 | \$2.015 |
| 25: BIW - BIW - BIW - Header - Panel | | | | | | | | |
| Header, Front, Lower (Item #48) | | | | | | | | |
| | | \$1.554 | \$0.087 | \$0.175 | \$0.097 | \$0.096 | \$0.153 | \$2.199 |
| 27: BIW - BIW - BIW - Header - Panel - Panel | | | | | | | | |
| Extension, Header, Front, Lower, Lh (Item #157) | | | | | | | | |
| | | \$0.658 | \$0.029 | \$0.069 | \$0.047 | \$0.040 | \$0.064 | \$0.924 |
| 30: BIW - BIW - BIW - Header - Panel - Panel | | | | | | | | |
| Extension, Header, Front, Lower, Rh (Item #157) | | | | | | | | |
| | | \$0.658 | \$0.029 | \$0.069 | \$0.047 | \$0.040 | \$0.064 | \$0.924 |
| 32: BIW - BIW - BIW - Header - Bracket | | | | | | | | |
| Overhead Console Mounting (Item #171) | | | | | | | | |
| | | \$0.567 | \$0.078 | \$0.165 | \$0.096 | \$0.045 | \$0.073 | \$1.040 |
| 34: BIW - BIW - BIW - Bow - Bow | | | | | | | | |
| Roof, "B" Pillar, Lower (Item #50) | | | | | | | | |
| | | \$7.846 | \$0.093 | \$0.200 | \$0.125 | \$0.413 | \$0.661 | \$9.518 |
| 35: BIW - BIW - BIW - Bow - Bow | | | | | | | | |

| | | | | | | | | |
|--|--|---------|---------|---------|---------|---------|---------|---------|
| Roof, "B" Pillar, Upper (Item #51) | | | | | | | | |
| | | \$2.594 | \$0.083 | \$0.166 | \$0.091 | \$0.147 | \$0.235 | \$3.376 |
| 37: BIW - BIW - BIW - Bow - Bow | | | | | | | | |
| Roof, #1 (Item #52) | | | | | | | | |
| | | \$1.203 | \$0.093 | \$0.187 | \$0.104 | \$0.079 | \$0.127 | \$1.824 |
| 39: BIW - BIW - BIW - Bow | | | | | | | | |
| Roof, #2 (Item #53) | | | | | | | | |
| | | \$0.804 | \$0.093 | \$0.187 | \$0.104 | \$0.059 | \$0.095 | \$1.364 |
| 40: BIW - BIW - BIW - Bow | | | | | | | | |
| Roof, #3 (Item #54) | | | | | | | | |
| | | \$1.774 | \$0.093 | \$0.187 | \$0.104 | \$0.108 | \$0.173 | \$2.482 |
| 41: BIW - BIW - BIW - Bow | | | | | | | | |
| Roof, #4 (Item #55) | | | | | | | | |
| | | \$0.779 | \$0.093 | \$0.187 | \$0.104 | \$0.058 | \$0.093 | \$1.335 |
| 43: BIW - BIW - BIW - Header - Panel | | | | | | | | |
| Extension, Header, Center, Lower, Liftgate Opening, Lh (Item #147) | | | | | | | | |
| | | \$3.968 | \$0.104 | \$0.370 | \$0.366 | \$0.240 | \$0.385 | \$5.523 |
| 44: BIW - BIW - BIW - Header - Panel | | | | | | | | |
| Header, Center, Lower, Liftgate Opening (Item #146) | | | | | | | | |
| | | \$1.737 | \$0.056 | \$0.153 | \$0.123 | \$0.103 | \$0.165 | \$2.380 |
| 45: BIW - BIW - BIW - Header - Panel | | | | | | | | |
| Extension, Header, Center, Lower, Liftgate Opening, Rh (Item #147) | | | | | | | | |
| | | \$3.968 | \$0.104 | \$0.370 | \$0.366 | \$0.240 | \$0.385 | \$5.523 |
| 47: BIW - BIW - BIW - Header - Panel - Panel | | | | | | | | |
| Header, Rear, Upper (Item #49) | | | | | | | | |
| | | \$2.044 | \$0.093 | \$0.187 | \$0.104 | \$0.121 | \$0.194 | \$2.793 |
| 51: BIW - BIW - BIW - BIW - Bodyside - Panel | | | | | | | | |



LOTUS ARB LWV PROGRAM

| | | | | | | | | |
|--|--|----------|---------|---------|---------|---------|---------|----------|
| Bodyside, Outer, Lh (Item #27) | | | | | | | | |
| | | \$45.293 | \$0.590 | \$2.331 | \$2.199 | \$2.521 | \$4.033 | \$58.001 |
| 52: BIW - BIW - BIW - BIW - Bodyside - Panel | | | | | | | | |
| "A" Pillar, Inner, Upper, Lh (Item #28) | | | | | | | | |
| | | \$4.757 | \$0.087 | \$0.324 | \$0.334 | \$0.275 | \$0.440 | \$6.324 |
| 53: BIW - BIW - BIW - BIW - Bodyside - Reinforcement | | | | | | | | |
| "A" Pillar, Lh (Item #30) | | | | | | | | |
| | | \$20.061 | \$0.121 | \$0.513 | \$0.536 | \$1.062 | \$1.699 | \$24.446 |
| 54: BIW - BIW - BIW - BIW - Bodyside - Panel | | | | | | | | |
| "B" Pillar, Inner, Lh (Item #31) | | | | | | | | |
| | | \$10.175 | \$0.132 | \$0.585 | \$0.650 | \$0.577 | \$0.923 | \$13.273 |
| 55: BIW - BIW - BIW - BIW - Bodyside - Reinforcement | | | | | | | | |
| "B" Pillar, Lh (Item #32) | | | | | | | | |
| | | \$13.915 | \$0.204 | \$0.560 | \$0.384 | \$0.753 | \$1.205 | \$17.336 |
| 56: BIW - BIW - BIW - BIW - Bodyside - Panel | | | | | | | | |
| Hinge Mounting, Rear Door, Lh (Item #33)(Hidden) | | | | | | | | |
| | | \$0.000 | \$0.000 | \$0.000 | \$0.000 | \$0.000 | \$0.000 | \$0.000 |
| 57: BIW - BIW - BIW - BIW - Bodyside - Reinforcement | | | | | | | | |
| Striker, Front Door, Lh (Item #34)(Hidden) | | | | | | | | |
| | | \$0.000 | \$0.000 | \$0.000 | \$0.000 | \$0.000 | \$0.000 | \$0.000 |
| 58: BIW - BIW - BIW - BIW - Bodyside - Panel | | | | | | | | |
| "C" Pillar, Inner, Upper, Lh (Item #35) | | | | | | | | |
| | | \$1.818 | \$0.088 | \$0.328 | \$0.336 | \$0.128 | \$0.206 | \$2.946 |
| 59: BIW - BIW - BIW - BIW - Bodyside - Reinforcement | | | | | | | | |
| Striker, Rear Door, Lh (Item #37)(Hidden) | | | | | | | | |
| | | \$0.000 | \$0.000 | \$0.000 | \$0.000 | \$0.000 | \$0.000 | \$0.000 |
| 60: BIW - BIW - BIW - BIW - Bodyside - Panel | | | | | | | | |

| | | | | | | | | |
|--|--|----------|---------|---------|---------|---------|---------|----------|
| Rear Quarter, Upper, Inner, Lh (Item #40) | | | | | | | | |
| | | \$3.009 | \$0.098 | \$0.344 | \$0.336 | \$0.189 | \$0.303 | \$4.347 |
| 62: BIW - BIW - BIW - BIW - Bodyside - Panel - Panel | | | | | | | | |
| Rear Wheelhouse, Inner, Lh (Item #41) | | | | | | | | |
| | | \$12.198 | \$0.173 | \$0.531 | \$0.459 | \$0.669 | \$1.069 | \$15.375 |
| 63: BIW - BIW - BIW - BIW - Bodyside - Panel - Bracket | | | | | | | | |
| Mounting, Rear Shock Tower, Upper, Lh (Item #18) | | | | | | | | |
| | | \$3.224 | \$0.095 | \$0.195 | \$0.086 | \$0.180 | \$0.288 | \$4.141 |
| 64: BIW - BIW - BIW - BIW - Bodyside - Panel - Reinforcement | | | | | | | | |
| Shock Tower, Rear, Upper, Lh (Item #44) | | | | | | | | |
| | | \$2.333 | \$0.045 | \$0.095 | \$0.058 | \$0.127 | \$0.203 | \$2.914 |
| 65: BIW - BIW - BIW - BIW - Bodyside - Panel | | | | | | | | |
| Rear Wheelhouse, Outer, Lh (Item #42) | | | | | | | | |
| | | \$12.801 | \$0.230 | \$0.581 | \$0.388 | \$0.700 | \$1.120 | \$16.111 |
| 66: BIW - BIW - BIW - BIW - Bodyside - Panel | | | | | | | | |
| Rear Wheelhouse, Front, Closeout, Lh (Item #43) | | | | | | | | |
| | | \$0.439 | \$0.036 | \$0.080 | \$0.052 | \$0.030 | \$0.049 | \$0.696 |
| 68: BIW - BIW - BIW - BIW - Bodyside - Panel - Panel | | | | | | | | |
| Roof Rail, Inner, Lh (Item #56) | | | | | | | | |
| | | \$7.553 | \$0.102 | \$0.363 | \$0.360 | \$0.419 | \$0.670 | \$9.638 |
| 69: BIW - BIW - BIW - BIW - Bodyside - Panel - Bracket | | | | | | | | |
| Mounting, Grab Handle (4 reqd.)(Sm. Part Batch) | | | | | | | | |
| | | \$0.000 | \$0.000 | \$0.000 | \$0.000 | \$0.000 | \$0.000 | \$0.000 |
| 72: BIW - BIW - BIW - BIW - Bodyside - Reinforcement | | | | | | | | |
| Roof Rail, Lh (Item #45) | | | | | | | | |
| | | \$11.576 | \$0.105 | \$0.372 | \$0.366 | \$0.621 | \$0.994 | \$14.296 |
| 73: BIW - BIW - BIW - BIW - Bodyside - Housing | | | | | | | | |

| | | | | | | | | |
|--|--|---------|---------|---------|---------|---------|---------|---------|
| Lamp, Rear, Lh (Item #38) | | | | | | | | |
| | | \$1.087 | \$0.098 | \$0.344 | \$0.336 | \$0.093 | \$0.149 | \$2.132 |
| 74: BIW - BIW - BIW - BIW - Bodyside - Panel | | | | | | | | |
| Closeout, Rear Wheelhouse, Lower, Rear, Lh (Item #138) | | | | | | | | |
| | | \$0.195 | \$0.026 | \$0.056 | \$0.033 | \$0.016 | \$0.025 | \$0.356 |
| 75: BIW - BIW - BIW - BIW - Bodyside - Bracket | | | | | | | | |
| Side Exhaust Hanger (Item #139) | | | | | | | | |
| | | \$0.323 | \$0.034 | \$0.082 | \$0.053 | \$0.025 | \$0.039 | \$0.565 |
| 76: BIW - BIW - BIW - BIW - Bodyside - Panel | | | | | | | | |
| Closeout, Sill Outer, Front, Lh (Item #140) | | | | | | | | |
| | | \$0.499 | \$0.084 | \$0.163 | \$0.050 | \$0.040 | \$0.064 | \$0.911 |
| 77: BIW - BIW - BIW - BIW - Bodyside - Panel | | | | | | | | |
| Sill, Outer, Lh (Item #141) | | | | | | | | |
| | | \$6.591 | \$0.120 | \$0.410 | \$0.392 | \$0.376 | \$0.601 | \$8.639 |
| 78: BIW - BIW - BIW - BIW - Bodyside - Panel | | | | | | | | |
| Closeout, Sill, Outer, Rear, Lh (Item #142) | | | | | | | | |
| | | \$3.232 | \$0.075 | \$0.300 | \$0.316 | \$0.196 | \$0.314 | \$4.518 |
| 79: BIW - BIW - BIW - BIW - Bodyside - Panel | | | | | | | | |
| "D" Pillar, Inner, Upper, Lh (Item #148) | | | | | | | | |
| | | \$2.979 | \$0.104 | \$0.370 | \$0.366 | \$0.191 | \$0.305 | \$4.383 |
| 80: BIW - BIW - BIW - BIW - Bodyside - Panel | | | | | | | | |
| "D" Pillar, Inner, Lower, Lh (Item #149) | | | | | | | | |
| | | \$2.180 | \$0.082 | \$0.339 | \$0.360 | \$0.148 | \$0.237 | \$3.396 |
| 81: BIW - BIW - BIW - BIW - Bodyside - Bracket | | | | | | | | |
| Trim Attach, Rear Compartment, Lh (Item #150) | | | | | | | | |
| | | \$0.515 | \$0.026 | \$0.070 | \$0.056 | \$0.033 | \$0.053 | \$0.767 |
| 82: BIW - BIW - BIW - BIW - Bodyside - Reinforcement | | | | | | | | |

| | | | | | | | | |
|--|--|----------|---------|---------|---------|---------|---------|----------|
| Rear Wheelhouse, Inner, Front, Lh (Item #153) | | | | | | | | |
| | | \$1.597 | \$0.093 | \$0.243 | \$0.163 | \$0.105 | \$0.168 | \$2.404 |
| 83: BIW - BIW - BIW - BIW - Bodyside - Panel | | | | | | | | |
| "C" Pillar, Inner, Mid, Lh (Item #154) | | | | | | | | |
| | | \$0.773 | \$0.062 | \$0.131 | \$0.050 | \$0.051 | \$0.081 | \$1.166 |
| 84: BIW - BIW - BIW - BIW - Bodyside - Panel | | | | | | | | |
| Transition, "A" Pillar Inner Lower to "A" Pillar Inner Upper, Lh (Item #158) | | | | | | | | |
| | | \$0.351 | \$0.018 | \$0.053 | \$0.043 | \$0.023 | \$0.037 | \$0.534 |
| 85: BIW - BIW - BIW - BIW - Bodyside - Bracket | | | | | | | | |
| Reinforcement, "A" Pillar, Lower, Lh (Item #159) | | | | | | | | |
| | | \$0.875 | \$0.049 | \$0.119 | \$0.087 | \$0.057 | \$0.090 | \$1.299 |
| 86: BIW - BIW - BIW - BIW - Bodyside - Panel | | | | | | | | |
| Trough, Outer, Upper, Liftgate, Lh (Item #172) | | | | | | | | |
| | | \$1.684 | \$0.092 | \$0.233 | \$0.160 | \$0.108 | \$0.173 | \$2.488 |
| 87: BIW - BIW - BIW - BIW - Bodyside - Panel | | | | | | | | |
| Trough, Outer, Lower, Liftgate, Lh (Item #173) | | | | | | | | |
| | | \$0.984 | \$0.069 | \$0.175 | \$0.132 | \$0.068 | \$0.109 | \$1.559 |
| 89: BIW - BIW - BIW - BIW - Bodyside - Panel | | | | | | | | |
| Bodyside, Outer, Rh (Item #27) | | | | | | | | |
| | | \$45.293 | \$0.590 | \$2.331 | \$2.199 | \$2.521 | \$4.033 | \$58.001 |
| 90: BIW - BIW - BIW - BIW - Bodyside - Panel | | | | | | | | |
| "A" Pillar, Inner, Upper, Rh (Item #28) | | | | | | | | |
| | | \$4.757 | \$0.087 | \$0.324 | \$0.334 | \$0.275 | \$0.440 | \$6.324 |
| 91: BIW - BIW - BIW - BIW - Bodyside - Reinforcement | | | | | | | | |
| "A" Pillar, Rh (Item #30) | | | | | | | | |
| | | \$20.061 | \$0.121 | \$0.513 | \$0.536 | \$1.062 | \$1.699 | \$24.446 |
| 92: BIW - BIW - BIW - BIW - Bodyside - Panel | | | | | | | | |

| | | | | | | | | |
|---|--|----------|---------|---------|---------|---------|---------|----------|
| "B" Pillar, Inner, Rh (Item #31) | | | | | | | | |
| | | \$10.175 | \$0.132 | \$0.585 | \$0.650 | \$0.577 | \$0.923 | \$13.273 |
| 93: BIW - BIW - BIW - BIW - Bodyside - Reinforcement | | | | | | | | |
| "B" Pillar, Rh (Item #32) | | | | | | | | |
| | | \$13.915 | \$0.204 | \$0.560 | \$0.384 | \$0.753 | \$1.205 | \$17.336 |
| 94: BIW - BIW - BIW - BIW - Bodyside - Panel | | | | | | | | |
| Hinge Mounting, Rear Door, Rh (Item #33)(Hidden) | | | | | | | | |
| | | \$0.000 | \$0.000 | \$0.000 | \$0.000 | \$0.000 | \$0.000 | \$0.000 |
| 95: BIW - BIW - BIW - BIW - Bodyside - Reinforcement | | | | | | | | |
| Striker, Front Door, Rh (Item #34)(Hidden) | | | | | | | | |
| | | \$0.000 | \$0.000 | \$0.000 | \$0.000 | \$0.000 | \$0.000 | \$0.000 |
| 96: BIW - BIW - BIW - BIW - Bodyside - Panel | | | | | | | | |
| "C" Pillar, Inner, Upper, Rh (Item #35) | | | | | | | | |
| | | \$1.818 | \$0.088 | \$0.328 | \$0.336 | \$0.128 | \$0.206 | \$2.946 |
| 97: BIW - BIW - BIW - BIW - Bodyside - Reinforcement | | | | | | | | |
| Striker, Rear Door, Rh (Item #37)(Hidden) | | | | | | | | |
| | | \$0.000 | \$0.000 | \$0.000 | \$0.000 | \$0.000 | \$0.000 | \$0.000 |
| 98: BIW - BIW - BIW - BIW - Bodyside - Panel | | | | | | | | |
| Rear Quarter, Upper, Inner, Rh (Item #40) | | | | | | | | |
| | | \$3.009 | \$0.098 | \$0.344 | \$0.336 | \$0.189 | \$0.303 | \$4.347 |
| 100: BIW - BIW - BIW - BIW - Bodyside - Panel - Panel | | | | | | | | |
| Rear Wheelhouse, Inner, Rh (Item #41) | | | | | | | | |
| | | \$12.198 | \$0.173 | \$0.531 | \$0.459 | \$0.669 | \$1.069 | \$15.375 |
| 101: BIW - BIW - BIW - BIW - Bodyside - Panel - Bracket | | | | | | | | |
| Mounting, Rear Shock Tower, Upper, Rh (Item #18) | | | | | | | | |
| | | \$3.224 | \$0.095 | \$0.195 | \$0.086 | \$0.180 | \$0.288 | \$4.141 |
| 102: BIW - BIW - BIW - BIW - Bodyside - Panel - Reinforcement | | | | | | | | |



LOTUS ARB LWV PROGRAM

| | | | | | | | | |
|---|--|----------|---------|---------|---------|---------|---------|----------|
| Shock Tower, Rear, Upper, Rh (Item #44) | | | | | | | | |
| | | \$2.333 | \$0.045 | \$0.095 | \$0.058 | \$0.127 | \$0.203 | \$2.914 |
| 103: BIW - BIW - BIW - BIW - Bodyside - Panel | | | | | | | | |
| Rear Wheelhouse, Outer, Rh (Item #42) | | | | | | | | |
| | | \$12.801 | \$0.230 | \$0.581 | \$0.388 | \$0.700 | \$1.120 | \$16.111 |
| 104: BIW - BIW - BIW - BIW - Bodyside - Panel | | | | | | | | |
| Rear Wheelhouse, Front, Closeout, Rh (Item #43) | | | | | | | | |
| | | \$0.439 | \$0.036 | \$0.080 | \$0.052 | \$0.030 | \$0.049 | \$0.696 |
| 106: BIW - BIW - BIW - BIW - Bodyside - Panel - Panel | | | | | | | | |
| Roof Rail, Inner, Rh (Item #56) | | | | | | | | |
| | | \$7.553 | \$0.102 | \$0.363 | \$0.360 | \$0.419 | \$0.670 | \$9.638 |
| 107: BIW - BIW - BIW - BIW - Bodyside - Panel - Bracket | | | | | | | | |
| Mounting, Grab Handle (4 reqd.)(In Hidden) | | | | | | | | |
| | | \$0.000 | \$0.000 | \$0.000 | \$0.000 | \$0.000 | \$0.000 | \$0.000 |
| 110: BIW - BIW - BIW - BIW - Bodyside - Reinforcement | | | | | | | | |
| Roof Rail, Rh (Item #45) | | | | | | | | |
| | | \$11.576 | \$0.105 | \$0.372 | \$0.366 | \$0.621 | \$0.994 | \$14.296 |
| 111: BIW - BIW - BIW - BIW - Bodyside - Housing | | | | | | | | |
| Lamp, Rear, Rh (Item #38) | | | | | | | | |
| | | \$1.087 | \$0.098 | \$0.344 | \$0.336 | \$0.093 | \$0.149 | \$2.132 |
| 112: BIW - BIW - BIW - BIW - Bodyside - Panel | | | | | | | | |
| Closeout, Rear Wheelhouse, Lower, Rear, Rh (Item #138) | | | | | | | | |
| | | \$0.195 | \$0.026 | \$0.056 | \$0.033 | \$0.016 | \$0.025 | \$0.356 |
| 113: BIW - BIW - BIW - BIW - Bodyside - Panel | | | | | | | | |
| Closeout, Sill Outer, Front, Rh (Item #140) | | | | | | | | |
| | | \$0.499 | \$0.084 | \$0.163 | \$0.050 | \$0.040 | \$0.064 | \$0.911 |
| 114: BIW - BIW - BIW - BIW - Bodyside - Panel | | | | | | | | |



LOTUS ARB LWV PROGRAM

| | | | | | | | | |
|--|--|---------|---------|---------|---------|---------|---------|---------|
| Sill, Outer, Rh (Item #141) | | | | | | | | |
| | | \$6.591 | \$0.120 | \$0.410 | \$0.392 | \$0.376 | \$0.601 | \$8.639 |
| 115: BIW - BIW - BIW - BIW - Bodyside - Panel | | | | | | | | |
| Closeout, Sill, Outer, Rear, Rh (Item #142) | | | | | | | | |
| | | \$3.232 | \$0.075 | \$0.300 | \$0.316 | \$0.196 | \$0.314 | \$4.518 |
| 116: BIW - BIW - BIW - BIW - Bodyside - Panel | | | | | | | | |
| "D" Pillar, Inner, Upper, Rh (Item #148) | | | | | | | | |
| | | \$2.979 | \$0.104 | \$0.370 | \$0.366 | \$0.191 | \$0.305 | \$4.383 |
| 117: BIW - BIW - BIW - BIW - Bodyside - Panel | | | | | | | | |
| "D" Pillar, Inner, Lower, Rh (Item #149) | | | | | | | | |
| | | \$2.180 | \$0.082 | \$0.339 | \$0.360 | \$0.148 | \$0.237 | \$3.396 |
| 118: BIW - BIW - BIW - BIW - Bodyside - Bracket | | | | | | | | |
| Trim Attach, Rear Compartment, Rh (Item #150) | | | | | | | | |
| | | \$0.515 | \$0.026 | \$0.070 | \$0.056 | \$0.033 | \$0.053 | \$0.767 |
| 119: BIW - BIW - BIW - BIW - Bodyside - Reinforcement | | | | | | | | |
| Rear Wheelhouse, Inner, Front, Rh (Item #153) | | | | | | | | |
| | | \$1.597 | \$0.093 | \$0.243 | \$0.163 | \$0.105 | \$0.168 | \$2.404 |
| 120: BIW - BIW - BIW - BIW - Bodyside - Panel | | | | | | | | |
| "C" Pillar, Inner, Mid, Rh (Item #154) | | | | | | | | |
| | | \$0.773 | \$0.062 | \$0.131 | \$0.050 | \$0.051 | \$0.081 | \$1.166 |
| 121: BIW - BIW - BIW - BIW - Bodyside - Panel | | | | | | | | |
| Transition, "A" Pillar Inner Lower to "A" Pillar Inner Upper, Rh (Item #158) | | | | | | | | |
| | | \$0.351 | \$0.018 | \$0.053 | \$0.043 | \$0.023 | \$0.037 | \$0.534 |
| 122: BIW - BIW - BIW - BIW - Bodyside - Bracket | | | | | | | | |
| Reinforcement, "A" Pillar, Lower, Rh (Item #159) | | | | | | | | |
| | | \$0.875 | \$0.049 | \$0.119 | \$0.087 | \$0.057 | \$0.090 | \$1.299 |
| 123: BIW - BIW - BIW - BIW - Bodyside - Panel | | | | | | | | |

| | | | | | | | | |
|---|--|---------|---------|---------|---------|---------|---------|---------|
| Trough, Outer, Upper, Liftgate, Rh (Item #172) | | | | | | | | |
| | | \$1.684 | \$0.092 | \$0.233 | \$0.160 | \$0.108 | \$0.173 | \$2.488 |
| 124: BIW - BIW - BIW - BIW - Bodyside - Panel | | | | | | | | |
| Trough, Outer, Lower, Liftgate, Rh (Item #173) | | | | | | | | |
| | | \$0.984 | \$0.069 | \$0.175 | \$0.132 | \$0.068 | \$0.109 | \$1.559 |
| 126: BIW - BIW - BIW - BIW - BIW - Panel | | | | | | | | |
| "A" Pillar, Inner, Lower, Lh (Item #29) | | | | | | | | |
| | | \$3.757 | \$0.093 | \$0.353 | \$0.366 | \$0.228 | \$0.365 | \$5.247 |
| 127: BIW - BIW - BIW - BIW - BIW - Panel | | | | | | | | |
| "A" Pillar, Inner, Lower, Rh (Item #29) | | | | | | | | |
| | | \$3.757 | \$0.093 | \$0.353 | \$0.366 | \$0.228 | \$0.365 | \$5.247 |
| 130: BIW - BIW - BIW - BIW - BIW - BIW - Panel - Panel | | | | | | | | |
| Rear End, Inner (Item #21) | | | | | | | | |
| | | \$4.449 | \$0.161 | \$0.634 | \$0.652 | \$0.295 | \$0.472 | \$6.764 |
| 131: BIW - BIW - BIW - BIW - BIW - BIW - Panel - Bracket | | | | | | | | |
| Reinforcement, ? (Hidden) | | | | | | | | |
| | | \$0.000 | \$0.000 | \$0.000 | \$0.000 | \$0.000 | \$0.000 | \$0.000 |
| 133: BIW - BIW - BIW - BIW - BIW - BIW - BIW - Panel | | | | | | | | |
| Reinforcement, Rear Rail, Upper, Lh (Item #145) | | | | | | | | |
| | | \$2.641 | \$0.068 | \$0.202 | \$0.150 | \$0.153 | \$0.245 | \$3.519 |
| 134: BIW - BIW - BIW - BIW - BIW - BIW - BIW - Panel | | | | | | | | |
| Reinforcement, Rear Rail, Upper, Rh (Item #145) | | | | | | | | |
| | | \$2.641 | \$0.068 | \$0.202 | \$0.150 | \$0.153 | \$0.245 | \$3.519 |
| 135: BIW - BIW - BIW - BIW - BIW - BIW - BIW - Panel | | | | | | | | |
| Extension, Crossmember, Front, Rear Compartment, Lh (Item #151) | | | | | | | | |
| | | \$1.721 | \$0.060 | \$0.127 | \$0.047 | \$0.098 | \$0.157 | \$2.249 |
| 136: BIW - BIW - BIW - BIW - BIW - BIW - BIW - Panel | | | | | | | | |

| | | | | | | | | |
|--|--|---------|---------|---------|---------|---------|---------|---------|
| Extension, Crossmember, Front, Rear Compartment, Rh (Item #151) | | | | | | | | |
| | | \$1.721 | \$0.060 | \$0.127 | \$0.047 | \$0.098 | \$0.157 | \$2.249 |
| 137: BIW - BIW - BIW - BIW - BIW - BIW - BIW - Reinforcement | | | | | | | | |
| Crossmember, Front, Rear Compartment, Lh (Item #152) | | | | | | | | |
| | | \$0.508 | \$0.013 | \$0.041 | \$0.034 | \$0.030 | \$0.048 | \$0.686 |
| 138: BIW - BIW - BIW - BIW - BIW - BIW - BIW - Reinforcement | | | | | | | | |
| Crossmember, Front, Rear Compartment, Rh (Item #152) | | | | | | | | |
| | | \$0.508 | \$0.013 | \$0.041 | \$0.034 | \$0.030 | \$0.048 | \$0.686 |
| 139: BIW - BIW - BIW - BIW - BIW - BIW - BIW - Panel | | | | | | | | |
| Reinforcement, Rail, Front, Upper, Lh (Item #160) | | | | | | | | |
| | | \$2.391 | \$0.046 | \$0.102 | \$0.065 | \$0.130 | \$0.208 | \$2.998 |
| 140: BIW - BIW - BIW - BIW - BIW - BIW - BIW - Panel | | | | | | | | |
| Extension, Front Seat Front Crossmember to Sill Inner, Lh (Item #161) | | | | | | | | |
| | | \$0.851 | \$0.029 | \$0.068 | \$0.046 | \$0.050 | \$0.080 | \$1.143 |
| 141: BIW - BIW - BIW - BIW - BIW - BIW - BIW - Panel | | | | | | | | |
| Extension, Front Seat Front Crossmember to Sill Inner, Rh (Item #161) | | | | | | | | |
| | | \$0.851 | \$0.029 | \$0.068 | \$0.046 | \$0.050 | \$0.080 | \$1.143 |
| 142: BIW - BIW - BIW - BIW - BIW - BIW - BIW - Reinforcement | | | | | | | | |
| Tunnel, at Front Seat Rear Crossmembers (Item #163) | | | | | | | | |
| | | \$1.582 | \$0.084 | \$0.189 | \$0.123 | \$0.099 | \$0.158 | \$2.274 |
| 143: BIW - BIW - BIW - BIW - BIW - BIW - BIW - Panel | | | | | | | | |
| Extension, Front Floor Pan, Rear (Item #175) | | | | | | | | |
| | | \$6.971 | \$0.180 | \$0.682 | \$0.646 | \$0.424 | \$0.679 | \$9.740 |
| 144: BIW - BIW - BIW - BIW - BIW - BIW - BIW - Panel | | | | | | | | |
| Extension, Reinforcement, Rail, Front, Upper, Front, Lh (Item #176) | | | | | | | | |
| | | \$1.095 | \$0.046 | \$0.102 | \$0.065 | \$0.065 | \$0.105 | \$1.504 |
| 146: BIW - BIW - BIW - BIW - BIW - BIW - BIW - Reinforcement - Reinforcement | | | | | | | | |



LOTUS ARB LWV PROGRAM

| | | | | | | | | |
|--|--|----------|---------|---------|---------|---------|---------|----------|
| Tunnel, Center, Upper (2 pc. Laser Welded Blank)(Item #7) | | | | | | | | |
| | | \$10.628 | \$0.240 | \$0.827 | \$0.676 | \$0.619 | \$0.990 | \$14.220 |
| 147: BIW - BIW - BIW - BIW - BIW - BIW - BIW - Reinforcement - Bracket | | | | | | | | |
| Front, Spacer (Sm. Part Batch) | | | | | | | | |
| | | \$0.000 | \$0.000 | \$0.000 | \$0.000 | \$0.000 | \$0.000 | \$0.000 |
| 149: BIW - BIW - BIW - BIW - BIW - BIW - BIW - Crossmember - Crossmember | | | | | | | | |
| Front, Seat, Front, Lh (Item #8) | | | | | | | | |
| | | \$2.878 | \$0.102 | \$0.320 | \$0.266 | \$0.178 | \$0.285 | \$4.105 |
| 153: BIW - BIW - BIW - BIW - BIW - BIW - BIW - Crossmember - Reinforcement - Reinforcement | | | | | | | | |
| ? (Hidden) | | | | | | | | |
| | | \$0.000 | \$0.000 | \$0.000 | \$0.000 | \$0.000 | \$0.000 | \$0.000 |
| 156: BIW - BIW - BIW - BIW - BIW - BIW - BIW - Crossmember - Crossmember | | | | | | | | |
| Front, Seat, Front, Rh (Item #8) | | | | | | | | |
| | | \$2.878 | \$0.102 | \$0.320 | \$0.266 | \$0.178 | \$0.285 | \$4.105 |
| 160: BIW - BIW - BIW - BIW - BIW - BIW - BIW - Crossmember - Reinforcement - Reinforcement | | | | | | | | |
| ? (Hidden) | | | | | | | | |
| | | \$0.000 | \$0.000 | \$0.000 | \$0.000 | \$0.000 | \$0.000 | \$0.000 |
| 163: BIW - BIW - BIW - BIW - BIW - BIW - BIW - Crossmember - Crossmember | | | | | | | | |
| Front, Seat, Rear, Lh (Item #9) | | | | | | | | |
| | | \$4.930 | \$0.065 | \$0.134 | \$0.080 | \$0.260 | \$0.417 | \$5.998 |
| 166: BIW - BIW - BIW - BIW - BIW - BIW - BIW - Crossmember - Extension - Panel | | | | | | | | |
| Extension, Front Seat Rear Crossmember to Sill Inner, Lh (Item #162) | | | | | | | | |
| | | \$1.792 | \$0.049 | \$0.111 | \$0.074 | \$0.101 | \$0.162 | \$2.331 |
| 169: BIW - BIW - BIW - BIW - BIW - BIW - BIW - Crossmember - Crossmember | | | | | | | | |
| Front, Seat, Rear, Rh (Item #9) | | | | | | | | |
| | | \$4.930 | \$0.065 | \$0.134 | \$0.080 | \$0.260 | \$0.417 | \$5.998 |
| 172: BIW - BIW - BIW - BIW - BIW - BIW - BIW - Crossmember - Extension - Panel | | | | | | | | |



LOTUS ARB LWV PROGRAM

| | | | | | | | | |
|--|--|----------|---------|---------|---------|---------|---------|----------|
| Extension, Front Seat Rear Crossmember to Sill Inner, Rh (Item #162) | | | | | | | | |
| | | \$1.792 | \$0.049 | \$0.111 | \$0.074 | \$0.101 | \$0.162 | \$2.331 |
| 175: BIW - BIW - BIW - BIW - BIW - BIW - BIW - Crossmember - Crossmember | | | | | | | | |
| Rear, Seat, Center (Item #10) | | | | | | | | |
| | | \$9.924 | \$0.149 | \$0.613 | \$0.631 | \$0.566 | \$0.905 | \$13.037 |
| 177: BIW - BIW - BIW - BIW - BIW - BIW - BIW - Crossmember - Reinforcement - Reinforcement | | | | | | | | |
| Crossmember, Rear, Seat, Center (Item #174) | | | | | | | | |
| | | \$12.273 | \$0.191 | \$1.152 | \$1.387 | \$0.750 | \$1.200 | \$17.232 |
| 179: BIW - BIW - BIW - BIW - BIW - BIW - BIW - Crossmember - Crossmember | | | | | | | | |
| Front, Rear Compartment (Item #16) | | | | | | | | |
| | | \$7.229 | \$0.149 | \$0.613 | \$0.631 | \$0.431 | \$0.690 | \$9.930 |
| 181: BIW - BIW - BIW - BIW - BIW - BIW - BIW - Crossmember - Bracket - Bracket | | | | | | | | |
| Nut Mounting (Hidden) | | | | | | | | |
| | | \$0.000 | \$0.000 | \$0.000 | \$0.000 | \$0.000 | \$0.000 | \$0.000 |
| 184: BIW - BIW - BIW - BIW - BIW - BIW - BIW - Crossmember - Bracket - Bracket | | | | | | | | |
| Nut Mounting (Hidden) | | | | | | | | |
| | | \$0.000 | \$0.000 | \$0.000 | \$0.000 | \$0.000 | \$0.000 | \$0.000 |
| 186: BIW - BIW - BIW - BIW - BIW - BIW - BIW - Panel | | | | | | | | |
| Closeout, Rear Compartment, Side, Inner, Lh (Item #17) | | | | | | | | |
| | | \$1.226 | \$0.202 | \$0.378 | \$0.106 | \$0.096 | \$0.153 | \$2.188 |
| 187: BIW - BIW - BIW - BIW - BIW - BIW - BIW - Panel | | | | | | | | |
| Closeout, Rear Compartment, Side, Inner, Rh (Item #17) | | | | | | | | |
| | | \$1.226 | \$0.202 | \$0.378 | \$0.106 | \$0.096 | \$0.153 | \$2.188 |
| 190: BIW - BIW - BIW - BIW - BIW - BIW - BIW - BIW - Dash - Panel | | | | | | | | |
| Dash (Item #57) | | | | | | | | |
| | | \$41.042 | \$0.332 | \$0.827 | \$0.568 | \$2.138 | \$3.422 | \$49.257 |
| 191: BIW - BIW - BIW - BIW - BIW - BIW - BIW - BIW - Dash - Reinforcement | | | | | | | | |

| | | | | | | | | |
|---|--|---------|---------|---------|---------|---------|---------|---------|
| Dash, Upper (Item #58) | | | | | | | | |
| | | \$3.182 | \$0.170 | \$0.678 | \$0.703 | \$0.237 | \$0.379 | \$5.421 |
| 193: BIW - BIW - BIW - BIW - BIW - BIW - BIW - BIW - Dash - Reinforcement - Reinforcement | | | | | | | | |
| Dash, Steering Column (Item #59) | | | | | | | | |
| | | \$1.343 | \$0.083 | \$0.223 | \$0.144 | \$0.090 | \$0.144 | \$2.062 |
| 196: BIW - BIW - BIW - BIW - BIW - BIW - BIW - BIW - Dash - Reinforcement - Reinforcement | | | | | | | | |
| Dash, Brake (Item #61) | | | | | | | | |
| | | \$0.493 | \$0.104 | \$0.196 | \$0.049 | \$0.042 | \$0.067 | \$0.963 |
| 198: BIW - BIW - BIW - BIW - BIW - BIW - BIW - BIW - Dash - Bracket | | | | | | | | |
| Mounting, Wiper Motor (Item #122) | | | | | | | | |
| | | \$0.313 | \$0.017 | \$0.050 | \$0.038 | \$0.021 | \$0.033 | \$0.481 |
| 199: BIW - BIW - BIW - BIW - BIW - BIW - BIW - BIW - Dash - Bracket | | | | | | | | |
| Reinforcement, Wind Shield, Center, Lower (Item #123) | | | | | | | | |
| | | \$0.127 | \$0.020 | \$0.058 | \$0.044 | \$0.013 | \$0.020 | \$0.286 |
| 200: BIW - BIW - BIW - BIW - BIW - BIW - BIW - BIW - Dash - Panel | | | | | | | | |
| Mounting, Plenum (Item #124) | | | | | | | | |
| | | \$0.776 | \$0.056 | \$0.123 | \$0.074 | \$0.051 | \$0.082 | \$1.183 |
| 201: BIW - BIW - BIW - BIW - BIW - BIW - BIW - BIW - Dash - Panel | | | | | | | | |
| Wind Shield, Lower (Item #125) | | | | | | | | |
| | | \$1.378 | \$0.074 | \$0.198 | \$0.160 | \$0.091 | \$0.145 | \$2.082 |
| 202: BIW - BIW - BIW - BIW - BIW - BIW - BIW - BIW - Dash - Reinforcement | | | | | | | | |
| Dash Panel Tunnel, Lower (Item #164) | | | | | | | | |
| | | \$1.490 | \$0.143 | \$0.284 | \$0.099 | \$0.101 | \$0.161 | \$2.311 |
| 203: BIW - BIW - BIW - BIW - BIW - BIW - BIW - BIW - Dash - Reinforcement | | | | | | | | |
| Dash Panel, Center (Item #165) | | | | | | | | |
| | | \$1.482 | \$0.143 | \$0.284 | \$0.099 | \$0.100 | \$0.161 | \$2.302 |
| 204: BIW - BIW - BIW - BIW - BIW - BIW - BIW - BIW - Dash - Reinforcement | | | | | | | | |

| | | | | | | | | |
|---|--|---------|---------|---------|---------|---------|---------|---------|
| Dash Panel, Upper, Lh (Item #166) | | | | | | | | |
| | | \$3.863 | \$0.095 | \$0.425 | \$0.461 | \$0.242 | \$0.388 | \$5.580 |
| 205: BIW - BIW - BIW - BIW - BIW - BIW - BIW - BIW - Dash - Reinforcement | | | | | | | | |
| Dash Panel, Wiper Motor (Item #167) | | | | | | | | |
| | | \$0.169 | \$0.025 | \$0.069 | \$0.052 | \$0.016 | \$0.025 | \$0.362 |
| 206: BIW - BIW - BIW - BIW - BIW - BIW - BIW - BIW - Dash - Reinforcement | | | | | | | | |
| Dash Panel, Rh (Item #170) | | | | | | | | |
| | | \$0.821 | \$0.143 | \$0.284 | \$0.099 | \$0.067 | \$0.108 | \$1.541 |
| 209: BIW - BIW - BIW - BIW - BIW - BIW - BIW - BIW - BIW - Module - Panel | | | | | | | | |
| Lower Radiator Support, Center (Item #100) | | | | | | | | |
| | | \$0.524 | \$0.043 | \$0.101 | \$0.066 | \$0.037 | \$0.059 | \$0.844 |
| 210: BIW - BIW - BIW - BIW - BIW - BIW - BIW - BIW - BIW - Module - Panel | | | | | | | | |
| Upper Radiator Support, Inner, Lh (Item #101) | | | | | | | | |
| | | \$0.880 | \$0.062 | \$0.136 | \$0.071 | \$0.058 | \$0.092 | \$1.319 |
| 211: BIW - BIW - BIW - BIW - BIW - BIW - BIW - BIW - BIW - Module - Panel | | | | | | | | |
| Upper Radiator Support, Inner, Rh (Item #101) | | | | | | | | |
| | | \$0.880 | \$0.062 | \$0.136 | \$0.071 | \$0.058 | \$0.092 | \$1.319 |
| 212: BIW - BIW - BIW - BIW - BIW - BIW - BIW - BIW - BIW - Module - Panel | | | | | | | | |
| Radiator Support/Headlamp, Inner, Upper, Lh (Item #102) | | | | | | | | |
| | | \$0.439 | \$0.068 | \$0.179 | \$0.125 | \$0.041 | \$0.065 | \$0.931 |
| 213: BIW - BIW - BIW - BIW - BIW - BIW - BIW - BIW - BIW - Module - Panel | | | | | | | | |
| Radiator Support/Headlamp, Inner, Upper, Rh (Item #102) | | | | | | | | |
| | | \$0.439 | \$0.068 | \$0.179 | \$0.125 | \$0.041 | \$0.065 | \$0.931 |
| 214: BIW - BIW - BIW - BIW - BIW - BIW - BIW - BIW - BIW - Module - Reinforcement | | | | | | | | |
| Upper Radiator Support, Inner, Front, Lower, Lh (Item #103) | | | | | | | | |
| | | \$0.166 | \$0.014 | \$0.041 | \$0.033 | \$0.013 | \$0.020 | \$0.292 |
| 215: BIW - BIW - BIW - BIW - BIW - BIW - BIW - BIW - BIW - Module - Reinforcement | | | | | | | | |

| | | | | | | | | |
|---|--|---------|---------|---------|---------|---------|---------|---------|
| Upper Radiator Support, Inner, Front, Lower, Rh (Item #103) | | | | | | | | |
| | | \$0.166 | \$0.014 | \$0.041 | \$0.033 | \$0.013 | \$0.020 | \$0.292 |
| 216: BIW - BIW - BIW - BIW - BIW - BIW - BIW - BIW - BIW - Module - Reinforcement | | | | | | | | |
| Upper Radiator Support, Inner, Front, Upper, Lh (Item #104) | | | | | | | | |
| | | \$0.171 | \$0.014 | \$0.042 | \$0.034 | \$0.013 | \$0.021 | \$0.301 |
| 217: BIW - BIW - BIW - BIW - BIW - BIW - BIW - BIW - BIW - Module - Reinforcement | | | | | | | | |
| Upper Radiator Support, Inner, Front, Upper, Rh (Item #104) | | | | | | | | |
| | | \$0.171 | \$0.014 | \$0.042 | \$0.034 | \$0.013 | \$0.021 | \$0.301 |
| 218: BIW - BIW - BIW - BIW - BIW - BIW - BIW - BIW - BIW - Module - Bracket | | | | | | | | |
| Mounting, Headlamp, Lower, Lh (Item #105) | | | | | | | | |
| | | \$0.058 | \$0.010 | \$0.030 | \$0.023 | \$0.006 | \$0.010 | \$0.140 |
| 219: BIW - BIW - BIW - BIW - BIW - BIW - BIW - BIW - BIW - Module - Bracket | | | | | | | | |
| Mounting, Headlamp, Lower, Rh (Item #105) | | | | | | | | |
| | | \$0.058 | \$0.010 | \$0.030 | \$0.023 | \$0.006 | \$0.010 | \$0.140 |
| 220: BIW - BIW - BIW - BIW - BIW - BIW - BIW - BIW - BIW - Module - Bracket | | | | | | | | |
| Mounting, Fascia, Front, Inner, Lower, Lh (Item #106) | | | | | | | | |
| | | \$0.187 | \$0.013 | \$0.037 | \$0.029 | \$0.013 | \$0.021 | \$0.306 |
| 221: BIW - BIW - BIW - BIW - BIW - BIW - BIW - BIW - BIW - Module - Bracket | | | | | | | | |
| Mounting, Fascia, Front, Inner, Lower, Rh (Item #106) | | | | | | | | |
| | | \$0.187 | \$0.013 | \$0.037 | \$0.029 | \$0.013 | \$0.021 | \$0.306 |
| 222: BIW - BIW - BIW - BIW - BIW - BIW - BIW - BIW - BIW - Module - Bracket | | | | | | | | |
| Mounting, Fascia, Front, Outer, Lower, Lh (Item #107) | | | | | | | | |
| | | \$0.213 | \$0.011 | \$0.032 | \$0.024 | \$0.014 | \$0.022 | \$0.321 |
| 223: BIW - BIW - BIW - BIW - BIW - BIW - BIW - BIW - BIW - Module - Bracket | | | | | | | | |
| Mounting, Fascia, Front, Outer, Lower, Rh (Item #107) | | | | | | | | |
| | | \$0.213 | \$0.011 | \$0.032 | \$0.024 | \$0.014 | \$0.022 | \$0.321 |
| 224: BIW - BIW - BIW - BIW - BIW - BIW - BIW - BIW - BIW - Module - Bracket | | | | | | | | |

| | | | | | | | | |
|---|--|---------|---------|---------|---------|---------|---------|---------|
| Mounting, Fascia, Front, Inner, Upper, Lh (Item #108) | | | | | | | | |
| | | \$0.222 | \$0.011 | \$0.032 | \$0.024 | \$0.014 | \$0.023 | \$0.332 |
| 225: BIW - BIW - BIW - BIW - BIW - BIW - BIW - BIW - BIW - Module - Bracket | | | | | | | | |
| Mounting, Fascia, Front, Inner, Upper, Rh (Item #108) | | | | | | | | |
| | | \$0.222 | \$0.011 | \$0.032 | \$0.024 | \$0.014 | \$0.023 | \$0.332 |
| 226: BIW - BIW - BIW - BIW - BIW - BIW - BIW - BIW - BIW - Module - Reinforcement | | | | | | | | |
| Headlamp, Lower, Lh (Item #109) | | | | | | | | |
| | | \$0.497 | \$0.065 | \$0.134 | \$0.080 | \$0.039 | \$0.062 | \$0.890 |
| 227: BIW - BIW - BIW - BIW - BIW - BIW - BIW - BIW - BIW - Module - Reinforcement | | | | | | | | |
| Headlamp, Lower, Rh (Item #109) | | | | | | | | |
| | | \$0.497 | \$0.065 | \$0.134 | \$0.080 | \$0.039 | \$0.062 | \$0.890 |
| 228: BIW - BIW - BIW - BIW - BIW - BIW - BIW - BIW - BIW - Module - Bracket | | | | | | | | |
| Mounting, Fascia, Outer, Lh (Item #110) | | | | | | | | |
| | | \$0.221 | \$0.012 | \$0.033 | \$0.025 | \$0.014 | \$0.023 | \$0.334 |
| 229: BIW - BIW - BIW - BIW - BIW - BIW - BIW - BIW - BIW - Module - Bracket | | | | | | | | |
| Mounting, Fascia, Outer, Rh (Item #110) | | | | | | | | |
| | | \$0.221 | \$0.012 | \$0.033 | \$0.025 | \$0.014 | \$0.023 | \$0.334 |
| 230: BIW - BIW - BIW - BIW - BIW - BIW - BIW - BIW - BIW - Module - Bracket | | | | | | | | |
| Brace, Front Wheelhouse, Lh (Item #111) | | | | | | | | |
| | | \$0.909 | \$0.084 | \$0.155 | \$0.059 | \$0.060 | \$0.097 | \$1.385 |
| 231: BIW - BIW - BIW - BIW - BIW - BIW - BIW - BIW - BIW - Module - Bracket | | | | | | | | |
| Brace, Front Wheelhouse, Rh (Item #111) | | | | | | | | |
| | | \$0.909 | \$0.084 | \$0.155 | \$0.059 | \$0.060 | \$0.097 | \$1.385 |
| 232: BIW - BIW - BIW - BIW - BIW - BIW - BIW - BIW - BIW - Module - Bracket | | | | | | | | |
| Mounting, Cradle, Front, Outer, Lh (Item #112) | | | | | | | | |
| | | \$1.294 | \$0.016 | \$0.048 | \$0.040 | \$0.070 | \$0.112 | \$1.609 |
| 233: BIW - BIW - BIW - BIW - BIW - BIW - BIW - BIW - BIW - Module - Bracket | | | | | | | | |

| | | | | | | | | |
|---|--|---------|---------|---------|---------|---------|---------|---------|
| Mounting, Cradle, Front, Outer, Rh (Item #112) | | | | | | | | |
| | | \$1.294 | \$0.016 | \$0.048 | \$0.040 | \$0.070 | \$0.112 | \$1.609 |
| 234: BIW - BIW - BIW - BIW - BIW - BIW - BIW - BIW - BIW - BIW - Module - Bracket | | | | | | | | |
| Mounting, Cradle, Front, Inner, Lh (Item #113) | | | | | | | | |
| | | \$1.316 | \$0.014 | \$0.041 | \$0.033 | \$0.070 | \$0.112 | \$1.618 |
| 235: BIW - BIW - BIW - BIW - BIW - BIW - BIW - BIW - BIW - BIW - Module - Bracket | | | | | | | | |
| Mounting, Cradle, Front, Inner, Rh (Item #113) | | | | | | | | |
| | | \$1.316 | \$0.014 | \$0.041 | \$0.033 | \$0.070 | \$0.112 | \$1.618 |
| 236: BIW - BIW - BIW - BIW - BIW - BIW - BIW - BIW - BIW - BIW - Module - Reinforcement | | | | | | | | |
| Headlamp, Outer, Lh (Item #114) | | | | | | | | |
| | | \$0.173 | \$0.092 | \$0.171 | \$0.054 | \$0.024 | \$0.039 | \$0.559 |
| 237: BIW - BIW - BIW - BIW - BIW - BIW - BIW - BIW - BIW - BIW - Module - Reinforcement | | | | | | | | |
| Headlamp, Outer, Rh (Item #114) | | | | | | | | |
| | | \$0.173 | \$0.092 | \$0.171 | \$0.054 | \$0.024 | \$0.039 | \$0.559 |
| 238: BIW - BIW - BIW - BIW - BIW - BIW - BIW - BIW - BIW - BIW - Module - Bracket | | | | | | | | |
| Mounting, Battery Tray (Item #115) | | | | | | | | |
| | | \$1.370 | \$0.143 | \$0.284 | \$0.099 | \$0.095 | \$0.152 | \$2.173 |
| 239: BIW - BIW - BIW - BIW - BIW - BIW - BIW - BIW - BIW - BIW - Module - Bracket | | | | | | | | |
| Mounting, Reservoir, Upper (Item #116) | | | | | | | | |
| | | \$1.271 | \$0.143 | \$0.282 | \$0.096 | \$0.090 | \$0.143 | \$2.053 |
| 240: BIW - BIW - BIW - BIW - BIW - BIW - BIW - BIW - BIW - BIW - Module - Bracket | | | | | | | | |
| Mounting, Reservoir, Lower (Item #117) | | | | | | | | |
| | | \$0.842 | \$0.110 | \$0.229 | \$0.075 | \$0.063 | \$0.100 | \$1.437 |
| 241: BIW - BIW - BIW - BIW - BIW - BIW - BIW - BIW - BIW - BIW - Module - Panel | | | | | | | | |
| Shotgun, Upper/Inner, (To "A" Pillar), Lh (Item #118) | | | | | | | | |
| | | \$0.965 | \$0.065 | \$0.232 | \$0.228 | \$0.075 | \$0.119 | \$1.715 |
| 242: BIW - BIW - BIW - BIW - BIW - BIW - BIW - BIW - BIW - BIW - Module - Panel | | | | | | | | |

| | | | | | | | | |
|---|--|---------|---------|---------|---------|---------|---------|---------|
| Shotgun, Upper/Inner, (To "A" Pillar), Rh (Item #118) | | | | | | | | |
| | | \$0.965 | \$0.065 | \$0.232 | \$0.228 | \$0.075 | \$0.119 | \$1.715 |
| 243: BIW - BIW - BIW - BIW - BIW - BIW - BIW - BIW - BIW - Module - Bracket | | | | | | | | |
| Mounting, Cowl, Lh (Item #119) | | | | | | | | |
| | | \$0.335 | \$0.012 | \$0.033 | \$0.025 | \$0.020 | \$0.032 | \$0.466 |
| 244: BIW - BIW - BIW - BIW - BIW - BIW - BIW - BIW - BIW - Module - Bracket | | | | | | | | |
| Mounting, Cowl, Rh (Item #119) | | | | | | | | |
| | | \$0.335 | \$0.012 | \$0.033 | \$0.025 | \$0.020 | \$0.032 | \$0.466 |
| 245: BIW - BIW - BIW - BIW - BIW - BIW - BIW - BIW - BIW - Module - Bracket | | | | | | | | |
| Transition, "A" Pillar to Shotgun, Lh (Item #120) | | | | | | | | |
| | | \$0.215 | \$0.010 | \$0.030 | \$0.023 | \$0.014 | \$0.022 | \$0.319 |
| 246: BIW - BIW - BIW - BIW - BIW - BIW - BIW - BIW - BIW - Module - Bracket | | | | | | | | |
| Transition, "A" Pillar to Shotgun, Rh (Item #120) | | | | | | | | |
| | | \$0.215 | \$0.010 | \$0.030 | \$0.023 | \$0.014 | \$0.022 | \$0.319 |
| 247: BIW - BIW - BIW - BIW - BIW - BIW - BIW - BIW - BIW - Module - Bracket | | | | | | | | |
| Mounting, Plenum, Outer, Lh (Item #121) | | | | | | | | |
| | | \$0.253 | \$0.065 | \$0.132 | \$0.045 | \$0.025 | \$0.040 | \$0.566 |
| 248: BIW - BIW - BIW - BIW - BIW - BIW - BIW - BIW - BIW - Module - Bracket | | | | | | | | |
| Mounting, Plenum, Outer, Rh (Item #121) | | | | | | | | |
| | | \$0.253 | \$0.065 | \$0.132 | \$0.045 | \$0.025 | \$0.040 | \$0.566 |
| 249: BIW - BIW - BIW - BIW - BIW - BIW - BIW - BIW - BIW - Module - Panel | | | | | | | | |
| Crush Rail, Front, Outer, Lh (Item #177) | | | | | | | | |
| | | \$5.193 | \$0.089 | \$0.378 | \$0.408 | \$0.303 | \$0.485 | \$6.989 |
| 250: BIW - BIW - BIW - BIW - BIW - BIW - BIW - BIW - BIW - Module - Panel | | | | | | | | |
| Crush Rail, Front, Outer, Rh (Item #177) | | | | | | | | |
| | | \$5.193 | \$0.089 | \$0.378 | \$0.408 | \$0.303 | \$0.485 | \$6.989 |
| 252: BIW - BIW - BIW - BIW - BIW - BIW - BIW - BIW - BIW - Module - Support - Support | | | | | | | | |

| | | | | | | | | |
|---|--|---------|---------|---------|---------|---------|---------|---------|
| Crash, Low Speed, Front, Lh (Item # 24) | | | | | | | | |
| | | \$2.098 | \$0.152 | \$0.294 | \$0.090 | \$0.132 | \$0.211 | \$3.023 |
| 256: BIW - BIW - BIW - BIW - BIW - BIW - BIW - BIW - BIW - Module - Support - Support | | | | | | | | |
| Crash, Low Speed, Front, Rh (Item # 24) | | | | | | | | |
| | | \$2.098 | \$0.152 | \$0.294 | \$0.090 | \$0.132 | \$0.211 | \$3.023 |
| 259: BIW - BIW - BIW - BIW - BIW - BIW - BIW - BIW - BIW - Module - Shotgun | | | | | | | | |
| Outer, Rear, Lh (Item #62) | | | | | | | | |
| | | \$1.236 | \$0.047 | \$0.115 | \$0.083 | \$0.074 | \$0.119 | \$1.704 |
| 260: BIW - BIW - BIW - BIW - BIW - BIW - BIW - BIW - BIW - Module - Shotgun | | | | | | | | |
| Outer, Rear, Rh (Item #62) | | | | | | | | |
| | | \$1.236 | \$0.047 | \$0.115 | \$0.083 | \$0.074 | \$0.119 | \$1.704 |
| 261: BIW - BIW - BIW - BIW - BIW - BIW - BIW - BIW - BIW - Module - Shotgun | | | | | | | | |
| Outer, Lh (Item #63) | | | | | | | | |
| | | \$0.974 | \$0.097 | \$0.294 | \$0.244 | \$0.081 | \$0.129 | \$1.840 |
| 262: BIW - BIW - BIW - BIW - BIW - BIW - BIW - BIW - BIW - Module - Shotgun | | | | | | | | |
| Outer, Rh (Item #63) | | | | | | | | |
| | | \$0.974 | \$0.097 | \$0.294 | \$0.244 | \$0.081 | \$0.129 | \$1.840 |
| 264: BIW - BIW - BIW - BIW - BIW - BIW - BIW - BIW - BIW - Module - Wheel House - Wheel House | | | | | | | | |
| Front, Lh (Item #64) | | | | | | | | |
| | | \$2.085 | \$0.185 | \$0.362 | \$0.114 | \$0.137 | \$0.220 | \$3.150 |
| 266: BIW - BIW - BIW - BIW - BIW - BIW - BIW - BIW - BIW - Module - Wheel House | | | | | | | | |
| Front, Rh Assembly | | | | | | | | |
| | | \$0.000 | \$0.000 | \$0.000 | \$0.000 | \$0.000 | \$0.000 | \$0.000 |
| 267: BIW - BIW - BIW - BIW - BIW - BIW - BIW - BIW - BIW - Module - Wheel House - Wheel House | | | | | | | | |
| Front, Rh (Item #64) | | | | | | | | |
| | | \$2.085 | \$0.185 | \$0.362 | \$0.114 | \$0.137 | \$0.220 | \$3.150 |
| 271: BIW - BIW - BIW - BIW - BIW - BIW - BIW - BIW - BIW - Module - Shock Tower - Shock Tower | | | | | | | | |

| | | | | | | | | |
|---|--|----------|---------|---------|---------|---------|---------|----------|
| Front, Lh (Item #66) | | | | | | | | |
| | | \$4.801 | \$0.116 | \$0.438 | \$0.432 | \$0.289 | \$0.463 | \$6.647 |
| 274: BIW - BIW - BIW - BIW - BIW - BIW - BIW - BIW - BIW - Module - Shock Tower - Shock Tower | | | | | | | | |
| Front, Rh (Item #66) | | | | | | | | |
| | | \$4.801 | \$0.116 | \$0.438 | \$0.432 | \$0.289 | \$0.463 | \$6.647 |
| 277: BIW - BIW - BIW - BIW - BIW - BIW - BIW - BIW - BIW - Module - Reinforcement - Reinforcement | | | | | | | | |
| Headlamp, Upper, Lh (Item #67) | | | | | | | | |
| | | \$0.845 | \$0.090 | \$0.239 | \$0.156 | \$0.066 | \$0.106 | \$1.521 |
| 280: BIW - BIW - BIW - BIW - BIW - BIW - BIW - BIW - BIW - Module - Reinforcement - Reinforcement | | | | | | | | |
| Headlamp, Upper, Rh (Item #67) | | | | | | | | |
| | | \$0.759 | \$0.090 | \$0.239 | \$0.156 | \$0.062 | \$0.099 | \$1.422 |
| 282: BIW - BIW - BIW - BIW - BIW - BIW - BIW - BIW - BIW - Module - Bracket | | | | | | | | |
| Mounting, Front Shock Upper, Lh (Item #68) | | | | | | | | |
| | | \$2.543 | \$0.091 | \$0.184 | \$0.077 | \$0.145 | \$0.232 | \$3.330 |
| 283: BIW - BIW - BIW - BIW - BIW - BIW - BIW - BIW - BIW - Module - Bracket | | | | | | | | |
| Mounting, Front Shock Upper, Rh (Item #68) | | | | | | | | |
| | | \$2.543 | \$0.091 | \$0.184 | \$0.077 | \$0.145 | \$0.232 | \$3.330 |
| 285: BIW - BIW - BIW - BIW - BIW - BIW - BIW - BIW - BIW - Module - Rail - Rail | | | | | | | | |
| Crush, Front, Inner, Lh (Item #69)(3 pc. Laser welded blank) | | | | | | | | |
| | | \$10.958 | \$0.246 | \$0.721 | \$0.453 | \$0.619 | \$0.990 | \$14.237 |
| 286: BIW - BIW - BIW - BIW - BIW - BIW - BIW - BIW - BIW - Module - Rail - Reinforcement | | | | | | | | |
| ?(Hidden) | | | | | | | | |
| | | \$0.000 | \$0.000 | \$0.000 | \$0.000 | \$0.000 | \$0.000 | \$0.000 |
| 289: BIW - BIW - BIW - BIW - BIW - BIW - BIW - BIW - BIW - Module - Rail - Rail | | | | | | | | |
| Crush, Front, Inner, Rh (Item #69)(3 pc. Laser welded blank) | | | | | | | | |
| | | \$10.958 | \$0.246 | \$0.721 | \$0.453 | \$0.619 | \$0.990 | \$14.237 |
| 290: BIW - BIW - BIW - BIW - BIW - BIW - BIW - BIW - BIW - Module - Rail - Reinforcement | | | | | | | | |

| | | | | | | | | |
|--|--|---------|---------|---------|---------|---------|---------|---------|
| ?(Hidden) | | | | | | | | |
| | | \$0.000 | \$0.000 | \$0.000 | \$0.000 | \$0.000 | \$0.000 | \$0.000 |
| 293: BIW - BIW - BIW - BIW - BIW - BIW - BIW - BIW - BIW - BIW - Module - Rail - Rail | | | | | | | | |
| Crush, Front, Outer, Front, Lh (Item #70) | | | | | | | | |
| | | \$0.719 | \$0.026 | \$0.064 | \$0.045 | \$0.043 | \$0.068 | \$0.982 |
| 294: BIW - BIW - BIW - BIW - BIW - BIW - BIW - BIW - BIW - BIW - Module - Rail - Reinforcement | | | | | | | | |
| (Sm. Part Batch) | | | | | | | | |
| | | \$0.000 | \$0.000 | \$0.000 | \$0.000 | \$0.000 | \$0.000 | \$0.000 |
| 297: BIW - BIW - BIW - BIW - BIW - BIW - BIW - BIW - BIW - BIW - Module - Rail - Rail | | | | | | | | |
| Crush, Front, Outer, Front, Rh (Item #70) | | | | | | | | |
| | | \$0.719 | \$0.026 | \$0.064 | \$0.045 | \$0.043 | \$0.068 | \$0.982 |
| 298: BIW - BIW - BIW - BIW - BIW - BIW - BIW - BIW - BIW - BIW - Module - Rail - Reinforcement | | | | | | | | |
| (Sm. Part Batch) | | | | | | | | |
| | | \$0.000 | \$0.000 | \$0.000 | \$0.000 | \$0.000 | \$0.000 | \$0.000 |
| 299: BIW - BIW - BIW - BIW - BIW - BIW - BIW - BIW - BIW - BIW - Module - Rail - Nut | | | | | | | | |
| Projection Weld | | | | | | | | |
| | | \$0.065 | \$0.000 | \$0.000 | \$0.000 | \$0.003 | \$0.000 | \$0.068 |
| 301: BIW - BIW - BIW - BIW - BIW - BIW - BIW - BIW - BIW - BIW - Module - Panel - Panel | | | | | | | | |
| Lower Radiator Support, Upper (Item #71) | | | | | | | | |
| | | \$3.499 | \$0.083 | \$0.166 | \$0.090 | \$0.192 | \$0.307 | \$4.418 |
| 305: BIW - BIW - BIW - BIW - BIW - BIW - BIW - BIW - BIW - BIW - Module - Panel - Panel | | | | | | | | |
| Lower Radiator Support, Lower, Lh (Item #72) | | | | | | | | |
| | | \$0.897 | \$0.056 | \$0.216 | \$0.227 | \$0.070 | \$0.112 | \$1.605 |
| 309: BIW - BIW - BIW - BIW - BIW - BIW - BIW - BIW - BIW - BIW - Module - Panel - Panel | | | | | | | | |
| Lower Radiator Support, Lower, Rh (Item #72) | | | | | | | | |
| | | \$0.897 | \$0.056 | \$0.216 | \$0.227 | \$0.070 | \$0.112 | \$1.605 |
| 315: BIW - BIW - BIW - BIW - BIW - BIW - BIW - BIW - BIW - BIW - Module - Member - Member - Member | | | | | | | | |

| | | | | | | | | |
|---|--|----------|---------|---------|---------|---------|---------|----------|
| Rail, Front, Lh (Item #1) | | | | | | | | |
| | | \$11.869 | \$0.173 | \$0.511 | \$0.361 | \$0.646 | \$1.033 | \$14.863 |
| 317: BIW - BIW - BIW - BIW - BIW - BIW - BIW - BIW - BIW - Module - Member - Member - Reinforcement - Reinforcement | | | | | | | | |
| Rail, Front, Lh (Hidden) | | | | | | | | |
| | | \$0.000 | \$0.000 | \$0.000 | \$0.000 | \$0.000 | \$0.000 | \$0.000 |
| 320: BIW - BIW - BIW - BIW - BIW - BIW - BIW - BIW - BIW - Module - Member - Member - Member | | | | | | | | |
| Rail, Mid, Lh (Item #128) | | | | | | | | |
| | | \$3.104 | \$0.068 | \$0.175 | \$0.137 | \$0.174 | \$0.279 | \$4.010 |
| 322: BIW - BIW - BIW - BIW - BIW - BIW - BIW - BIW - BIW - Module - Member - Member | | | | | | | | |
| Rail, Rear Cap, Lh (Item #129) | | | | | | | | |
| | | \$0.692 | \$0.057 | \$0.119 | \$0.041 | \$0.045 | \$0.073 | \$1.043 |
| 325: BIW - BIW - BIW - BIW - BIW - BIW - BIW - BIW - BIW - Module - Member - Member - Member | | | | | | | | |
| Rail, Front, Rh (Item #1) | | | | | | | | |
| | | \$11.869 | \$0.173 | \$0.511 | \$0.361 | \$0.646 | \$1.033 | \$14.863 |
| 327: BIW - BIW - BIW - BIW - BIW - BIW - BIW - BIW - BIW - Module - Member - Member - Reinforcement - Reinforcement | | | | | | | | |
| Rail, Front, Rh (Hidden) | | | | | | | | |
| | | \$0.000 | \$0.000 | \$0.000 | \$0.000 | \$0.000 | \$0.000 | \$0.000 |
| 330: BIW - BIW - BIW - BIW - BIW - BIW - BIW - BIW - BIW - Module - Member - Member - Member | | | | | | | | |
| Rail, Mid, Rh (Item #128) | | | | | | | | |
| | | \$3.104 | \$0.068 | \$0.175 | \$0.137 | \$0.174 | \$0.279 | \$4.010 |
| 332: BIW - BIW - BIW - BIW - BIW - BIW - BIW - BIW - BIW - Module - Member - Member | | | | | | | | |
| Rail, Rear Cap, Rh (Item #129) | | | | | | | | |
| | | \$0.692 | \$0.057 | \$0.119 | \$0.041 | \$0.045 | \$0.073 | \$1.043 |
| 334: BIW - BIW - BIW - BIW - BIW - BIW - BIW - BIW - BIW - Module - Crossmember - Member | | | | | | | | |
| Kickup, Front, Lh, Assembly | | | | | | | | |
| | | \$0.000 | \$0.000 | \$0.000 | \$0.000 | \$0.000 | \$0.000 | \$0.000 |

| | | | | | | | | |
|--|--|---------|---------|---------|---------|---------|---------|---------|
| 335: BIW - BIW - BIW - BIW - BIW - BIW - BIW - BIW - BIW - Module - Crossmember - Member - Member | | | | | | | | |
| Kickup, Front, Lh (Item #2) | | | | | | | | |
| | | \$3.027 | \$0.168 | \$0.353 | \$0.143 | \$0.185 | \$0.295 | \$4.240 |
| 337: BIW - BIW - BIW - BIW - BIW - BIW - BIW - BIW - BIW - Module - Crossmember - Member - Bracket - Bracket | | | | | | | | |
| Reinforcement, Kickup, Lh (Hidden) | | | | | | | | |
| | | \$0.000 | \$0.000 | \$0.000 | \$0.000 | \$0.000 | \$0.000 | \$0.000 |
| 339: BIW - BIW - BIW - BIW - BIW - BIW - BIW - BIW - BIW - Module - Crossmember - Crossmember - Crossmember | | | | | | | | |
| Toeboard, Lh (Item #6) | | | | | | | | |
| | | \$2.028 | \$0.081 | \$0.225 | \$0.155 | \$0.125 | \$0.199 | \$2.858 |
| 342: BIW - BIW - BIW - BIW - BIW - BIW - BIW - BIW - BIW - Module - Crossmember - Crossmember - Crossmember | | | | | | | | |
| Toeboard, Rh (Item #6) | | | | | | | | |
| | | \$2.588 | \$0.081 | \$0.225 | \$0.155 | \$0.153 | \$0.244 | \$3.504 |
| 344: BIW - BIW - BIW - BIW - BIW - BIW - BIW - BIW - BIW - Module - Crossmember - Member | | | | | | | | |
| Kickup, Front, Rh, Assembly | | | | | | | | |
| | | \$0.000 | \$0.000 | \$0.000 | \$0.000 | \$0.000 | \$0.000 | \$0.000 |
| 345: BIW - BIW - BIW - BIW - BIW - BIW - BIW - BIW - BIW - Module - Crossmember - Member - Member | | | | | | | | |
| Kickup, Front, Rh (Item #2) | | | | | | | | |
| | | \$2.273 | \$0.168 | \$0.353 | \$0.143 | \$0.147 | \$0.235 | \$3.371 |
| 347: BIW - BIW - BIW - BIW - BIW - BIW - BIW - BIW - BIW - Module - Crossmember - Member - Bracket - Bracket | | | | | | | | |
| Reinforcement, Kickup, Rh (Hidden) | | | | | | | | |
| | | \$0.000 | \$0.000 | \$0.000 | \$0.000 | \$0.000 | \$0.000 | \$0.000 |
| 348: BIW - BIW - BIW - BIW - BIW - BIW - BIW - BIW - BIW - Module - Panel | | | | | | | | |
| Sill, Side, Inner, Lh (Item #3) | | | | | | | | |



LOTUS ARB LWV PROGRAM

| | | | | | | | | |
|---|--|---------|---------|---------|---------|---------|---------|---------|
| | | \$6.837 | \$0.132 | \$0.420 | \$0.383 | \$0.389 | \$0.622 | \$8.937 |
| 349: BIW - BIW - BIW - BIW - BIW - BIW - BIW - BIW - BIW - Module - Panel | | | | | | | | |
| Sill, Side, Inner, Rh (Item #3) | | | | | | | | |
| | | \$6.837 | \$0.132 | \$0.420 | \$0.383 | \$0.389 | \$0.622 | \$8.937 |
| 351: BIW - BIW - BIW - BIW - BIW - BIW - BIW - BIW - BIW - Module - Extension - Extension | | | | | | | | |
| Rail to Sill Front, Lh (Item #4) | | | | | | | | |
| | | \$4.629 | \$0.116 | \$0.250 | \$0.114 | \$0.255 | \$0.409 | \$5.878 |
| 353: BIW - BIW - BIW - BIW - BIW - BIW - BIW - BIW - BIW - Module - Extension - Bracket - Bracket | | | | | | | | |
| Reinforcement, Tow Hook, Lh (Sm. Part Batch) | | | | | | | | |
| | | \$0.000 | \$0.000 | \$0.000 | \$0.000 | \$0.000 | \$0.000 | \$0.000 |
| 355: BIW - BIW - BIW - BIW - BIW - BIW - BIW - BIW - BIW - Module - Extension - Bracket | | | | | | | | |
| ?, Lh (Sm. Part Batch) | | | | | | | | |
| | | \$0.000 | \$0.000 | \$0.000 | \$0.000 | \$0.000 | \$0.000 | \$0.000 |
| 357: BIW - BIW - BIW - BIW - BIW - BIW - BIW - BIW - BIW - Module - Extension - Extension | | | | | | | | |
| Rail to Sill Front, Rh (Item #4) | | | | | | | | |
| | | \$4.629 | \$0.116 | \$0.250 | \$0.114 | \$0.255 | \$0.409 | \$5.878 |
| 359: BIW - BIW - BIW - BIW - BIW - BIW - BIW - BIW - BIW - Module - Extension - Bracket - Bracket | | | | | | | | |
| Reinforcement, Tow Hook, Rh (Sm. Part Batch) | | | | | | | | |
| | | \$0.000 | \$0.000 | \$0.000 | \$0.000 | \$0.000 | \$0.000 | \$0.000 |
| 361: BIW - BIW - BIW - BIW - BIW - BIW - BIW - BIW - BIW - Module - Extension - Bracket | | | | | | | | |
| ?, Rh (Sm. Part Batch) | | | | | | | | |
| | | \$0.000 | \$0.000 | \$0.000 | \$0.000 | \$0.000 | \$0.000 | \$0.000 |
| 363: BIW - BIW - BIW - BIW - BIW - BIW - BIW - BIW - BIW - Module - Crossmember - Crossmember | | | | | | | | |
| Rear Torquebox (Item #11) | | | | | | | | |
| | | \$6.142 | \$0.158 | \$0.625 | \$0.646 | \$0.379 | \$0.606 | \$8.694 |
| 366: BIW - BIW - BIW - BIW - BIW - BIW - BIW - BIW - BIW - Module - Panel | | | | | | | | |
| Floor, Front (Item #12) | | | | | | | | |

| | | | | | | | | |
|---|--|----------|---------|---------|---------|---------|---------|----------|
| | | \$17.962 | \$0.277 | \$0.753 | \$0.598 | \$0.980 | \$1.567 | \$22.544 |
| 368: BIW - BIW - BIW - BIW - BIW - BIW - BIW - BIW - BIW - Module - Panel - Panel | | | | | | | | |
| Floor, Mid (Rear Seat) (Item #13) | | | | | | | | |
| | | \$10.456 | \$0.226 | \$0.564 | \$0.387 | \$0.582 | \$0.931 | \$13.382 |
| 371: BIW - BIW - BIW - BIW - BIW - BIW - BIW - BIW - BIW - Module - Panel - Bracket - Bracket | | | | | | | | |
| Anchor, Seat Belt, Rear, Lh (Item #155) | | | | | | | | |
| | | \$0.696 | \$0.021 | \$0.068 | \$0.057 | \$0.042 | \$0.067 | \$0.969 |
| 374: BIW - BIW - BIW - BIW - BIW - BIW - BIW - BIW - BIW - Module - Panel - Bracket - Bracket | | | | | | | | |
| Anchor, Seat Belt, Rear, Rh (Item #156) | | | | | | | | |
| | | \$0.412 | \$0.020 | \$0.060 | \$0.045 | \$0.027 | \$0.043 | \$0.617 |
| 377: BIW - BIW - BIW - BIW - BIW - BIW - BIW - BIW - BIW - Module - Panel - Panel - Panel | | | | | | | | |
| Reinforcement, Rear Seat Panel (Item #133) | | | | | | | | |
| | | \$3.202 | \$0.050 | \$0.227 | \$0.221 | \$0.185 | \$0.296 | \$4.261 |
| 381: BIW - BIW - BIW - BIW - BIW - BIW - BIW - BIW - BIW - Module - Panel - Panel - Bracket - Bracket | | | | | | | | |
| Underbody Mounting Stud (Sm.Part Batch) | | | | | | | | |
| | | \$0.000 | \$0.000 | \$0.000 | \$0.000 | \$0.000 | \$0.000 | \$0.000 |
| 383: BIW - BIW - BIW - BIW - BIW - BIW - BIW - BIW - BIW - Module - Panel | | | | | | | | |
| Extension, Sill, Side, Inner, Front, Lh (Item #168) | | | | | | | | |
| | | \$1.278 | \$0.029 | \$0.081 | \$0.066 | \$0.073 | \$0.116 | \$1.674 |
| 384: BIW - BIW - BIW - BIW - BIW - BIW - BIW - BIW - BIW - Module - Panel | | | | | | | | |
| Extension, Sill, Side, Inner, Front, Rh (Item #168) | | | | | | | | |
| | | \$1.278 | \$0.029 | \$0.081 | \$0.066 | \$0.073 | \$0.116 | \$1.674 |
| 385: BIW - BIW - BIW - BIW - BIW - BIW - BIW - BIW - BIW - Module - Extension | | | | | | | | |
| Sill, Side, Rear, Lh (Item #14) | | | | | | | | |
| | | \$5.087 | \$0.072 | \$0.275 | \$0.282 | \$0.286 | \$0.457 | \$6.573 |
| 386: BIW - BIW - BIW - BIW - BIW - BIW - BIW - BIW - BIW - Module - Extension | | | | | | | | |
| Sill, Side, Rear, Rh (Item #14) | | | | | | | | |



LOTUS ARB LWV PROGRAM

| | | | | | | | | |
|---|--|----------|---------|---------|---------|---------|---------|----------|
| | | \$5.087 | \$0.072 | \$0.275 | \$0.282 | \$0.286 | \$0.457 | \$6.573 |
| 387: BIW - BIW - BIW - BIW - BIW - BIW - BIW - BIW - BIW - Module - Member | | | | | | | | |
| Rail, Rear, Lh (Item #15) | | | | | | | | |
| | | \$3.266 | \$0.064 | \$0.260 | \$0.280 | \$0.194 | \$0.310 | \$4.447 |
| 388: BIW - BIW - BIW - BIW - BIW - BIW - BIW - BIW - BIW - Module - Member | | | | | | | | |
| Rail, Rear, Rh (Item #15) | | | | | | | | |
| | | \$3.266 | \$0.064 | \$0.260 | \$0.280 | \$0.194 | \$0.310 | \$4.447 |
| 389: BIW - BIW - BIW - BIW - BIW - BIW - BIW - BIW - BIW - Module - Panel | | | | | | | | |
| Floor, Rear Compartment (Trunk) (Item #19) | | | | | | | | |
| | | \$12.716 | \$0.188 | \$0.467 | \$0.320 | \$0.685 | \$1.095 | \$15.758 |
| 390: BIW - BIW - BIW - BIW - BIW - BIW - BIW - BIW - BIW - Module - Reinforcement | | | | | | | | |
| Tunnel, Front Seat, Front Crossmember (Item #126) | | | | | | | | |
| | | \$4.444 | \$0.126 | \$0.384 | \$0.288 | \$0.262 | \$0.420 | \$6.025 |
| 391: BIW - BIW - BIW - BIW - BIW - BIW - BIW - BIW - BIW - Module - Panel | | | | | | | | |
| Mounting, 4 Wheel Drive Shifter (Item #127) | | | | | | | | |
| | | \$5.206 | \$0.120 | \$0.373 | \$0.288 | \$0.299 | \$0.479 | \$6.895 |
| 392: BIW - BIW - BIW - BIW - BIW - BIW - BIW - BIW - BIW - Module - Bracket | | | | | | | | |
| Mounting, Fuel Tank, Lh (Item #130) | | | | | | | | |
| | | \$1.470 | \$0.135 | \$0.273 | \$0.078 | \$0.098 | \$0.156 | \$2.244 |
| 393: BIW - BIW - BIW - BIW - BIW - BIW - BIW - BIW - BIW - Module - Bracket | | | | | | | | |
| Mounting, Fuel Tank, Rh (Item #130) | | | | | | | | |
| | | \$1.796 | \$0.136 | \$0.275 | \$0.079 | \$0.114 | \$0.183 | \$2.624 |
| 394: BIW - BIW - BIW - BIW - BIW - BIW - BIW - BIW - BIW - Module - Bracket | | | | | | | | |
| Support, Sill to Front Floor Rear, Lh (Item #131) | | | | | | | | |
| | | \$0.592 | \$0.014 | \$0.041 | \$0.031 | \$0.034 | \$0.054 | \$0.781 |
| 395: BIW - BIW - BIW - BIW - BIW - BIW - BIW - BIW - BIW - Module - Bracket | | | | | | | | |
| Support, Sill to Front Floor Rear, Rh (Item #131) | | | | | | | | |

| | | | | | | | | |
|---|--|---------|---------|---------|---------|---------|---------|----------|
| | | \$0.592 | \$0.014 | \$0.041 | \$0.031 | \$0.034 | \$0.054 | \$0.781 |
| 396: BIW - BIW - BIW - BIW - BIW - BIW - BIW - BIW - BIW - Module - Bracket | | | | | | | | |
| Jounce, Rear, Lh (Item #132) | | | | | | | | |
| | | \$1.786 | \$0.050 | \$0.158 | \$0.134 | \$0.106 | \$0.170 | \$2.451 |
| 397: BIW - BIW - BIW - BIW - BIW - BIW - BIW - BIW - BIW - Module - Bracket | | | | | | | | |
| Jounce, Rear, Rh (Item #132) | | | | | | | | |
| | | \$1.786 | \$0.050 | \$0.158 | \$0.134 | \$0.106 | \$0.170 | \$2.451 |
| 398: BIW - BIW - BIW - BIW - BIW - BIW - BIW - BIW - BIW - Module - Member | | | | | | | | |
| Rail, Rear/Front, Lh (Item #134) | | | | | | | | |
| | | \$8.787 | \$0.195 | \$0.522 | \$0.322 | \$0.492 | \$0.786 | \$11.304 |
| 399: BIW - BIW - BIW - BIW - BIW - BIW - BIW - BIW - BIW - Module - Member | | | | | | | | |
| Rail, Rear/Front, Rh (Item #134) | | | | | | | | |
| | | \$7.351 | \$0.195 | \$0.522 | \$0.322 | \$0.420 | \$0.671 | \$9.648 |
| 400: BIW - BIW - BIW - BIW - BIW - BIW - BIW - BIW - BIW - Module - Bracket | | | | | | | | |
| Mounting, Rear Axel, Front, Lh (Item #135) | | | | | | | | |
| | | \$0.850 | \$0.013 | \$0.047 | \$0.043 | \$0.048 | \$0.076 | \$1.098 |
| 401: BIW - BIW - BIW - BIW - BIW - BIW - BIW - BIW - BIW - Module - Bracket | | | | | | | | |
| Mounting, Rear Axel, Front, Rh (Item #135) | | | | | | | | |
| | | \$0.850 | \$0.013 | \$0.047 | \$0.043 | \$0.048 | \$0.076 | \$1.098 |
| 402: BIW - BIW - BIW - BIW - BIW - BIW - BIW - BIW - BIW - Module - Bracket | | | | | | | | |
| Mounting, Rear Axel, Rear, Lh (Item #136) | | | | | | | | |
| | | \$0.576 | \$0.013 | \$0.047 | \$0.043 | \$0.034 | \$0.054 | \$0.783 |
| 403: BIW - BIW - BIW - BIW - BIW - BIW - BIW - BIW - BIW - Module - Bracket | | | | | | | | |
| Mounting, Rear Axel, Rear, Rh (Item #136) | | | | | | | | |
| | | \$0.576 | \$0.013 | \$0.047 | \$0.043 | \$0.034 | \$0.054 | \$0.783 |
| 404: BIW - BIW - BIW - BIW - BIW - BIW - BIW - BIW - BIW - Module - Bracket | | | | | | | | |
| Shield Attach, Lh (Item #137) | | | | | | | | |



LOTUS ARB LWV PROGRAM

| | | | | | | | | |
|---|--------------|-----------|----------|----------|----------|----------|----------|-------------|
| | | \$0.251 | \$0.012 | \$0.033 | \$0.025 | \$0.016 | \$0.026 | \$0.368 |
| 405: BIW - BIW - BIW - BIW - BIW - BIW - BIW - BIW - BIW - Module - Bracket | | | | | | | | |
| Shield Attach, Rh (Item #137) | | | | | | | | |
| | | \$0.213 | \$0.012 | \$0.033 | \$0.025 | \$0.014 | \$0.023 | \$0.324 |
| 406: BIW - BIW | | | | | | | | |
| Hidden Stampings Batch Pricing (Approx. Qty. 60) | | | | | | | | |
| | | \$48.390 | \$1.944 | \$5.784 | \$4.284 | \$3.024 | \$4.836 | \$69.498 |
| 407: BIW - BIW | | | | | | | | |
| Small Stampings Batch Pricing (Qty. 15) | | | | | | | | |
| | | \$7.743 | \$0.452 | \$1.275 | \$0.879 | \$0.518 | \$0.828 | \$11.900 |
| | Total | \$894.764 | \$23.040 | \$67.340 | \$52.586 | \$51.890 | \$83.018 | \$1,193.483 |

Table C.b: Phase 2 HD vehicle piece costs

| Part Number | Part Name | Direct Cost | Fixed Cost | Variable Cost | Material Cost | SG&A | Profit | Freight | Total Cost |
|---|-------------------------------------|----------------|-----------------|-----------------|-------------------|----------------|-----------------|----------------|-------------------|
| Complete body - less bumpers and fenders | | \$37.71 | \$138.62 | \$135.63 | \$1,260.63 | \$78.63 | \$125.81 | \$25.01 | \$1,802.01 |
| Front End | | | | | | | | | |
| 7305-2400-209 | Front end module | \$1.36 | \$4.55 | \$5.03 | \$13.24 | \$1.21 | \$1.93 | \$0.00 | \$27.32 |
| 7305-2400-001 | Small crossmember reinforcement | \$0.03 | \$0.06 | \$0.08 | \$3.49 | \$0.18 | \$0.29 | \$0.08 | \$4.22 |
| 7305-2400-002 | Large crossmember reinforcement | \$0.03 | \$0.10 | \$0.11 | \$4.43 | \$0.23 | \$0.37 | \$0.10 | \$5.38 |
| Sub-total | | \$1.41 | \$4.72 | \$5.22 | \$21.15 | \$1.63 | \$2.60 | \$0.18 | \$36.92 |
| Left-side Bodyside Outer Assembly | | | | | | | | | |
| 7306-2300-185 | Rear panel | \$0.32 | \$1.87 | \$1.67 | \$51.88 | \$2.79 | \$4.46 | \$1.18 | \$64.17 |
| 7306-2300-183 | Front panel | \$0.10 | \$0.10 | \$0.23 | \$2.48 | \$0.15 | \$0.23 | \$0.06 | \$3.36 |
| 7306-2300-187 | Lower, rear, quarter panel closeout | \$0.08 | \$0.14 | \$0.22 | \$3.88 | \$0.22 | \$0.35 | \$0.09 | \$4.97 |
| 7306-2300-189 | Flange to body panel | \$0.02 | \$0.07 | \$0.08 | \$4.92 | \$0.25 | \$0.41 | \$0.11 | \$5.86 |
| 7306-2300-191 | Tail lamp close out panel | \$0.01 | \$0.03 | \$0.04 | \$0.77 | \$0.04 | \$0.07 | \$0.02 | \$0.98 |
| Sub-total | | \$0.54 | \$2.20 | \$2.25 | \$63.93 | \$3.45 | \$5.51 | \$1.46 | \$79.33 |
| Right-side Bodyside Outer Assembly | | | | | | | | | |
| 7306-2300-186 | Rear panel | \$0.32 | \$1.87 | \$1.67 | \$51.88 | \$2.79 | \$4.46 | \$1.18 | \$64.17 |
| 7306-2300-184 | Front panel | \$0.10 | \$0.10 | \$0.23 | \$2.48 | \$0.15 | \$0.23 | \$0.06 | \$3.36 |
| 7306-2300-188 | Lower, rear, quarter panel closeout | \$0.08 | \$0.14 | \$0.22 | \$3.88 | \$0.22 | \$0.35 | \$0.09 | \$4.97 |
| 7306-2300-190 | Flange to body panel | \$0.02 | \$0.07 | \$0.08 | \$4.92 | \$0.25 | \$0.41 | \$0.11 | \$5.86 |
| 7306-2300-192 | Tail lamp close out panel | \$0.01 | \$0.03 | \$0.04 | \$0.77 | \$0.04 | \$0.07 | \$0.02 | \$0.98 |
| Sub-total | | \$0.54 | \$2.20 | \$2.25 | \$63.93 | \$3.45 | \$5.51 | \$1.46 | \$79.33 |
| Roof and Header | | | | | | | | | |
| 7306-2200-109 | Roof panel | \$0.25 | \$0.83 | \$0.93 | \$48.12 | \$2.51 | \$4.01 | \$1.09 | \$57.74 |
| 7306-2000-215 | Rear roof side rail inner - left | \$0.10 | \$0.31 | \$0.35 | \$9.69 | \$0.52 | \$0.84 | \$0.22 | \$12.03 |
| 7306-2000-171 | Front roof side rail inner - left | \$0.10 | \$0.32 | \$0.36 | \$10.39 | \$0.56 | \$0.89 | \$0.24 | \$12.85 |
| 7306-2000-216 | Rear roof side rail inner - right | \$0.10 | \$0.31 | \$0.35 | \$9.69 | \$0.52 | \$0.84 | \$0.22 | \$12.03 |
| 7306-2000-172 | Front roof side rail inner - right | \$0.10 | \$0.32 | \$0.36 | \$10.39 | \$0.56 | \$0.89 | \$0.24 | \$12.85 |
| 7306-2100-101 | Front header | \$0.09 | \$0.67 | \$0.56 | \$15.41 | \$0.84 | \$1.34 | \$0.37 | \$19.28 |
| 7306-2100-103 | Center header | \$0.05 | \$0.08 | \$0.13 | \$8.33 | \$0.43 | \$0.69 | \$0.19 | \$9.89 |
| 7307-2100-104 | Rear header | \$0.15 | \$0.60 | \$0.63 | \$12.77 | \$0.71 | \$1.13 | \$0.29 | \$16.29 |
| Sub-total | | \$0.93 | \$3.45 | \$3.68 | \$124.78 | \$6.64 | \$10.63 | \$2.86 | \$152.97 |
| Left-side D-Pillar Assembly | | | | | | | | | |
| 7307-2110-179 | Liftgate reinforcement | \$0.11 | \$0.14 | \$0.27 | \$8.15 | \$0.43 | \$0.69 | \$0.18 | \$9.99 |
| 7307-2110-105 | D-pillar inner | \$0.15 | \$0.46 | \$0.53 | \$15.02 | \$0.81 | \$1.29 | \$0.34 | \$18.60 |
| 7307-2110-177 | Quarter panel inner | \$0.10 | \$0.38 | \$0.40 | \$11.83 | \$0.64 | \$1.02 | \$0.27 | \$14.63 |
| Sub-total | | \$0.36 | \$0.99 | \$1.20 | \$35.00 | \$1.88 | \$3.00 | \$0.79 | \$43.22 |

| Right-side D-Pillar Assembly | | | | | | | | | |
|-------------------------------------|--------------------------------|---------------|---------------|---------------|----------------|---------------|---------------|---------------|----------------|
| 7307-2120-180 | Liftgate reinforcement | \$0.11 | \$0.14 | \$0.27 | \$8.15 | \$0.43 | \$0.69 | \$0.18 | \$9.99 |
| 7307-2120-106 | D-pillar inner | \$0.15 | \$0.46 | \$0.53 | \$15.02 | \$0.81 | \$1.29 | \$0.34 | \$18.60 |
| 7307-2120-178 | Quarter panel inner | \$0.10 | \$0.38 | \$0.40 | \$11.83 | \$0.64 | \$1.02 | \$0.27 | \$14.63 |
| Sub-total | | \$0.36 | \$0.99 | \$1.20 | \$35.00 | \$1.88 | \$3.00 | \$0.79 | \$43.22 |
| Shotgun Closeouts | | | | | | | | | |
| 7305-1900-159 | Shotgun closeout panel - left | \$0.01 | \$0.01 | \$0.02 | \$0.38 | \$0.02 | \$0.03 | \$0.01 | \$0.48 |
| 7305-1900-160 | Shotgun closeout panel - right | \$0.01 | \$0.01 | \$0.02 | \$0.38 | \$0.02 | \$0.03 | \$0.01 | \$0.48 |
| Sub-total | | \$0.01 | \$0.03 | \$0.04 | \$0.75 | \$0.04 | \$0.07 | \$0.02 | \$0.96 |
| Lower Left A-Pillar Outer Assembly | | | | | | | | | |
| 7305-1930-169 | Shotgun outer panel | \$0.12 | \$0.34 | \$0.41 | \$7.95 | \$0.44 | \$0.71 | \$0.18 | \$10.15 |
| 7305-1930-187 | Lower panel | \$0.13 | \$0.36 | \$0.44 | \$35.99 | \$1.85 | \$2.95 | \$0.82 | \$42.54 |
| 7305-1930-171 | Upper hinge reinforcement | \$0.01 | \$0.01 | \$0.02 | \$0.20 | \$0.01 | \$0.02 | \$0.00 | \$0.27 |
| 7305-1930-173 | Lower hinge reinforcement | \$0.01 | \$0.01 | \$0.02 | \$0.18 | \$0.01 | \$0.02 | \$0.00 | \$0.24 |
| Sub-total | | \$0.27 | \$0.72 | \$0.89 | \$44.32 | \$2.31 | \$3.70 | \$1.01 | \$53.21 |
| Lower Right A-Pillar Outer Assembly | | | | | | | | | |
| 7305-1940-170 | Shotgun outer panel | \$0.12 | \$0.34 | \$0.41 | \$7.95 | \$0.44 | \$0.71 | \$0.18 | \$10.15 |
| 7305-1940-188 | Lower panel | \$0.13 | \$0.36 | \$0.44 | \$35.99 | \$1.85 | \$2.95 | \$0.82 | \$42.54 |
| 7305-1940-184 | Upper hinge reinforcement | \$0.01 | \$0.01 | \$0.02 | \$0.20 | \$0.01 | \$0.02 | \$0.00 | \$0.27 |
| 7305-1940-186 | Lower hinge reinforcement | \$0.01 | \$0.01 | \$0.02 | \$0.18 | \$0.01 | \$0.02 | \$0.00 | \$0.24 |
| Sub-total | | \$0.27 | \$0.72 | \$0.89 | \$44.32 | \$2.31 | \$3.70 | \$1.01 | \$53.21 |
| Right Door Aperature Assembly | | | | | | | | | |
| Right B-Pillar Sub-Assembly | | | | | | | | | |
| 7306-1920-190 | Upper A-pillar outer panel | \$0.10 | \$0.31 | \$0.35 | \$12.82 | \$0.68 | \$1.09 | \$0.29 | \$15.64 |
| 7306-1920-192 | Outer roof side rail | \$0.10 | \$0.31 | \$0.35 | \$9.47 | \$0.51 | \$0.82 | \$0.21 | \$11.77 |
| 7306-1920-194 | C-pillar striker reinforcement | \$0.01 | \$0.02 | \$0.03 | \$0.39 | \$0.02 | \$0.04 | \$0.01 | \$0.52 |
| 7306-1920-196 | C-pillar outer | \$0.17 | \$0.46 | \$0.57 | \$38.20 | \$1.97 | \$3.15 | \$0.87 | \$45.39 |
| Sub-total | | \$0.38 | \$1.11 | \$1.31 | \$60.87 | \$3.18 | \$5.09 | \$1.38 | \$73.32 |
| Right B-Pillar Outer Sub-Assembly | | | | | | | | | |
| 7306-1924-002 | Lower B-pillar outer | \$0.15 | \$0.57 | \$0.60 | \$13.87 | \$0.76 | \$1.22 | \$0.32 | \$17.48 |
| 7306-1924-004 | Upper B-pillar outer | \$0.07 | \$0.28 | \$0.29 | \$5.77 | \$0.32 | \$0.51 | \$0.13 | \$7.38 |
| 7306-1924-006 | Upper, inner reinforcement | \$0.02 | \$0.04 | \$0.05 | \$0.68 | \$0.04 | \$0.06 | \$0.02 | \$0.91 |
| 7306-1924-008 | Middle, inner reinforcement | \$0.01 | \$0.02 | \$0.03 | \$0.32 | \$0.02 | \$0.03 | \$0.01 | \$0.44 |
| 7306-1924-010 | Lower, inner reinforcement | \$0.02 | \$0.04 | \$0.05 | \$0.79 | \$0.05 | \$0.07 | \$0.02 | \$1.04 |
| Sub-total | | \$0.27 | \$0.95 | \$1.03 | \$21.43 | \$1.18 | \$1.89 | \$0.49 | \$27.25 |
| Right B-Pillar Inner Sub-Assembly | | | | | | | | | |
| 7306-1926-012 | Lower B-pillar inner | \$0.14 | \$0.44 | \$0.49 | \$10.40 | \$0.57 | \$0.92 | \$0.24 | \$13.20 |
| 7306-1915-001 | Beltline reinforcement plate | \$0.01 | \$0.01 | \$0.01 | \$0.09 | \$0.01 | \$0.01 | \$0.00 | \$0.13 |
| 7306-1926-014 | B-pillar, upper, inner | \$0.02 | \$0.03 | \$0.05 | \$1.73 | \$0.09 | \$0.15 | \$0.04 | \$2.11 |
| Sub-total | | \$0.16 | \$0.48 | \$0.55 | \$12.22 | \$0.67 | \$1.07 | \$0.28 | \$15.44 |
| Left Door Aperature Assembly | | | | | | | | | |
| Left B-Pillar Sub-Assembly | | | | | | | | | |
| 7306-1910-189 | Upper A-pillar outer panel | \$0.10 | \$0.31 | \$0.35 | \$12.82 | \$0.68 | \$1.09 | \$0.29 | \$15.64 |
| 7306-1910-191 | Outer roof side rail | \$0.10 | \$0.31 | \$0.35 | \$9.47 | \$0.51 | \$0.82 | \$0.21 | \$11.77 |

| | | | | | | | | | |
|---|---------------------------------|---------------|---------------|---------------|----------------|---------------|---------------|---------------|----------------|
| 7306-1910-193 | C-pillar striker reinforcement | \$0.01 | \$0.02 | \$0.03 | \$0.39 | \$0.02 | \$0.04 | \$0.01 | \$0.52 |
| 7306-1910-195 | C-pillar outer | \$0.17 | \$0.46 | \$0.57 | \$38.20 | \$1.97 | \$3.15 | \$0.87 | \$45.39 |
| Sub-total | | \$0.38 | \$1.11 | \$1.31 | \$60.87 | \$3.18 | \$5.09 | \$1.38 | \$73.32 |
| Left B-Pillar Outer Sub-Assembly | | | | | | | | | |
| 7306-1913-001 | Lower B-pillar outer | \$0.15 | \$0.57 | \$0.60 | \$13.87 | \$0.76 | \$1.22 | \$0.32 | \$17.48 |
| 7306-1913-003 | Upper B-pillar outer | \$0.07 | \$0.28 | \$0.29 | \$5.77 | \$0.32 | \$0.51 | \$0.13 | \$7.38 |
| 7306-1913-005 | Upper, inner reinforcement | \$0.02 | \$0.04 | \$0.05 | \$0.68 | \$0.04 | \$0.06 | \$0.02 | \$0.91 |
| 7306-1913-007 | Middle, inner reinforcement | \$0.01 | \$0.02 | \$0.03 | \$0.32 | \$0.02 | \$0.03 | \$0.01 | \$0.44 |
| 7306-1913-009 | Lower, inner reinforcement | \$0.02 | \$0.04 | \$0.05 | \$0.79 | \$0.05 | \$0.07 | \$0.02 | \$1.04 |
| Sub-total | | \$0.27 | \$0.95 | \$1.03 | \$21.43 | \$1.18 | \$1.89 | \$0.49 | \$27.25 |
| Left B-Pillar Inner Sub-Assembly | | | | | | | | | |
| 7306-1915-011 | Lower B-pillar inner | \$0.14 | \$0.44 | \$0.49 | \$10.40 | \$0.57 | \$0.92 | \$0.24 | \$13.20 |
| 7306-1915-001 | Beltline reinforcement plate | \$0.01 | \$0.01 | \$0.01 | \$0.09 | \$0.01 | \$0.01 | \$0.00 | \$0.13 |
| 7306-1915-013 | B-pillar, upper, inner | \$0.02 | \$0.03 | \$0.05 | \$1.73 | \$0.09 | \$0.15 | \$0.04 | \$2.11 |
| Sub-total | | \$0.16 | \$0.48 | \$0.55 | \$12.22 | \$0.67 | \$1.07 | \$0.28 | \$15.44 |
| Cowl | | | | | | | | | |
| 7305-1800-145 | Upper cowl panel | \$0.47 | \$2.98 | \$2.41 | \$15.34 | \$1.06 | \$1.70 | \$0.00 | \$23.95 |
| 7305-1700-147 | Cowl support | \$0.14 | \$0.61 | \$0.61 | \$15.99 | \$0.87 | \$1.39 | \$0.36 | \$19.98 |
| Sub-total | | \$0.61 | \$3.59 | \$3.02 | \$31.33 | \$1.93 | \$3.08 | \$0.36 | \$43.93 |
| Left Dash Transmission Assembly | | | | | | | | | |
| 7305-1530-221 | Dash-transmission reinforcement | \$0.24 | \$0.22 | \$0.55 | \$16.35 | \$0.87 | \$1.39 | \$0.37 | \$19.98 |
| 7305-1530-223 | Dash-transmission insert | \$0.02 | \$0.03 | \$0.05 | \$0.97 | \$0.05 | \$0.09 | \$0.02 | \$1.24 |
| Sub-total | | \$0.26 | \$0.25 | \$0.60 | \$17.32 | \$0.92 | \$1.47 | \$0.39 | \$21.23 |
| Right Dash Transmission Assembly | | | | | | | | | |
| 7305-1520-222 | Dash-transmission reinforcement | \$0.24 | \$0.22 | \$0.55 | \$16.35 | \$0.87 | \$1.39 | \$0.37 | \$19.98 |
| 7305-1520-224 | Dash-transmission insert | \$0.02 | \$0.03 | \$0.05 | \$0.97 | \$0.05 | \$0.09 | \$0.02 | \$1.24 |
| Sub-total | | \$0.26 | \$0.25 | \$0.60 | \$17.32 | \$0.92 | \$1.47 | \$0.39 | \$21.23 |
| Rear End Panel Assembly | | | | | | | | | |
| 7307-1510-111 | Outer panel | \$0.17 | \$0.55 | \$0.63 | \$18.46 | \$0.99 | \$1.58 | \$0.42 | \$22.80 |
| 7307-1510-117 | Inner panel | \$0.17 | \$0.55 | \$0.63 | \$27.63 | \$1.45 | \$2.32 | \$0.63 | \$33.37 |
| Sub-total | | \$0.35 | \$1.09 | \$1.25 | \$46.09 | \$2.44 | \$3.90 | \$1.05 | \$56.17 |
| Rear Crossmember Assembly | | | | | | | | | |
| 7307-1410-119 | Rear compartment crossmember | \$1.18 | \$4.59 | \$4.19 | \$13.30 | \$1.16 | \$1.86 | \$0.55 | \$26.80 |
| 7307-1410-120 | Hanger bracket extrusion | \$0.28 | \$0.49 | \$0.72 | \$0.54 | \$0.10 | \$0.16 | \$0.03 | \$2.33 |
| Sub-total | | \$1.45 | \$5.09 | \$4.92 | \$13.84 | \$1.26 | \$2.02 | \$0.58 | \$29.12 |
| Left Front Wheelhouse Assembly | | | | | | | | | |
| 7305-1310-151 | Front shock tower | \$0.50 | \$2.24 | \$1.90 | \$4.93 | \$0.48 | \$0.77 | \$0.00 | \$10.82 |
| 7305-1310-161 | Front wheelhouse panel | \$0.42 | \$2.41 | \$1.95 | \$12.54 | \$0.87 | \$1.39 | \$0.00 | \$19.58 |
| Sub-total | | \$0.92 | \$4.65 | \$3.85 | \$17.47 | \$1.34 | \$2.15 | \$0.00 | \$30.39 |
| Right Front Wheelhouse Assembly | | | | | | | | | |
| 7305-1320-152 | Front shock tower | \$0.50 | \$2.24 | \$1.90 | \$4.93 | \$0.48 | \$0.77 | \$0.00 | \$10.82 |
| 7305-1320-162 | Front wheelhouse panel | \$0.42 | \$2.42 | \$1.95 | \$12.54 | \$0.87 | \$1.39 | \$0.00 | \$19.59 |



LOTUS ARB LWV PROGRAM

| | | | | | | | | | |
|--|---|---------------|---------------|---------------|----------------|---------------|---------------|---------------|----------------|
| Sub-total | | \$0.92 | \$4.66 | \$3.85 | \$17.47 | \$1.35 | \$2.15 | \$0.00 | \$30.40 |
| Rear Seat Pan Assembly | | | | | | | | | |
| 7306-1200-113 | Rear seat panel floor | \$0.17 | \$0.39 | \$0.52 | \$23.52 | \$1.23 | \$1.97 | \$0.53 | \$28.32 |
| 7306-1200-111 | Seatbelt anchrage plate - right and left | \$0.01 | \$0.02 | \$0.04 | \$0.54 | \$0.03 | \$0.05 | \$0.01 | \$0.69 |
| 7307-1200-218 | Rear frame rail outer transition - right | \$0.57 | \$3.56 | \$2.80 | \$13.02 | \$1.00 | \$1.60 | \$0.00 | \$22.54 |
| 7307-1200-217 | Rear frame rail outer transition - left | \$0.57 | \$3.56 | \$2.80 | \$13.02 | \$1.00 | \$1.60 | \$0.00 | \$22.54 |
| Sub-total | | \$1.32 | \$7.52 | \$6.16 | \$50.08 | \$3.25 | \$5.21 | \$0.55 | \$74.09 |
| Rear Center Seat Riser Assembly | | | | | | | | | |
| 7306-1110-101 | Rear center seat riser | \$0.08 | \$0.24 | \$0.28 | \$9.84 | \$0.52 | \$0.84 | \$0.23 | \$12.03 |
| 7306-1110-103 | Rear seat floor reinforcement - left | \$0.03 | \$0.06 | \$0.08 | \$1.09 | \$0.06 | \$0.10 | \$0.03 | \$1.44 |
| 7306-1000-176 | Rear seat riser - right | \$0.12 | \$0.26 | \$0.36 | \$4.51 | \$0.26 | \$0.42 | \$0.10 | \$6.03 |
| 7306-1000-175 | Rear seat riser - left | \$0.12 | \$0.26 | \$0.36 | \$4.51 | \$0.26 | \$0.42 | \$0.10 | \$6.03 |
| Sub-total | | \$0.35 | \$0.81 | \$1.08 | \$19.95 | \$1.11 | \$1.78 | \$0.47 | \$25.54 |
| Rear Frame Rail Assembly | | | | | | | | | |
| 7307-1000-139 | Rear frame rail - right and left | \$1.39 | \$4.53 | \$4.45 | \$12.80 | \$1.16 | \$1.85 | \$0.50 | \$26.69 |
| 7307-1000-138 | Rear frame rail mounting plate - right and left | \$0.02 | \$0.03 | \$0.05 | \$1.79 | \$0.09 | \$0.15 | \$0.04 | \$2.18 |
| Sub-total | | \$1.41 | \$4.56 | \$4.50 | \$14.59 | \$1.25 | \$2.01 | \$0.54 | \$28.86 |
| Right Front Frame Rail Assembly | | | | | | | | | |
| 7307-1020-136 | Front frame rail | \$0.62 | \$2.08 | \$2.04 | \$4.72 | \$0.47 | \$0.76 | \$0.20 | \$10.89 |
| 7307-1020-224 | Front frame rail mounting plate | \$0.02 | \$0.03 | \$0.05 | \$1.29 | \$0.07 | \$0.11 | \$0.03 | \$1.60 |
| Sub-total | | \$0.63 | \$2.11 | \$2.09 | \$6.01 | \$0.54 | \$0.87 | \$0.23 | \$12.49 |
| Right Front Rail Mount Sub-Assembly | | | | | | | | | |
| 7307-1011-001 | Front rail mount | \$0.03 | \$0.06 | \$0.09 | \$0.86 | \$0.05 | \$0.08 | \$0.02 | \$1.20 |
| 7307-1011-003 | Front rail mount cvr - left and right | \$0.03 | \$0.05 | \$0.08 | \$1.29 | \$0.07 | \$0.12 | \$0.03 | \$1.66 |
| Sub-total | | \$0.06 | \$0.11 | \$0.16 | \$2.15 | \$0.12 | \$0.20 | \$0.05 | \$2.85 |
| Left Front Frame Rail Assembly | | | | | | | | | |
| 7307-1010-135 | Front frame rail | \$0.62 | \$2.08 | \$2.04 | \$4.72 | \$0.47 | \$0.76 | \$0.20 | \$10.89 |
| 7307-1010-223 | Front frame rail mounting plate | \$0.02 | \$0.03 | \$0.05 | \$1.29 | \$0.07 | \$0.11 | \$0.03 | \$1.60 |
| Sub-total | | \$0.63 | \$2.11 | \$2.09 | \$6.01 | \$0.54 | \$0.87 | \$0.23 | \$12.49 |
| Left Front Rail Mount Sub-Assembly | | | | | | | | | |
| 7307-1011-001 | Front rail mount | \$0.03 | \$0.06 | \$0.09 | \$0.86 | \$0.05 | \$0.08 | \$0.02 | \$1.20 |
| 7307-1011-003 | Front rail mount cvr - left and right | \$0.03 | \$0.05 | \$0.08 | \$1.29 | \$0.07 | \$0.12 | \$0.03 | \$1.66 |
| Sub-total | | \$0.06 | \$0.11 | \$0.16 | \$2.15 | \$0.12 | \$0.20 | \$0.05 | \$2.85 |
| Transitions | | | | | | | | | |
| 7305-1200-210 | Front frame rail outer transition - right | \$0.51 | \$2.92 | \$2.29 | \$9.44 | \$0.76 | \$1.21 | \$0.00 | \$17.14 |
| 7305-1200-209 | Front frame rail outer transition - left | \$0.51 | \$2.92 | \$2.29 | \$9.44 | \$0.76 | \$1.21 | \$0.00 | \$17.14 |
| 7305-0900-138 | Front frame rail inner transition - right | \$0.51 | \$2.92 | \$2.29 | \$9.34 | \$0.75 | \$1.20 | \$0.00 | \$17.02 |

| | | | | | | | | | |
|--|--|---------------|----------------|----------------|----------------|---------------|---------------|---------------|-----------------|
| 7305-0900-137 | Front frame rail inner transition - left | \$0.51 | \$2.92 | \$2.29 | \$9.34 | \$0.75 | \$1.20 | \$0.00 | \$17.02 |
| 7307-0900-142 | Rear frame rail inner transition - right | \$0.54 | \$3.21 | \$2.51 | \$10.36 | \$0.83 | \$1.33 | \$0.00 | \$18.78 |
| 7307-0900-141 | Rear frame rail inner transition - left | \$0.54 | \$3.21 | \$2.51 | \$10.36 | \$0.83 | \$1.33 | \$0.00 | \$18.78 |
| Sub-total | | \$3.11 | \$18.11 | \$14.18 | \$58.29 | \$4.68 | \$7.49 | \$0.00 | \$105.86 |
| Small Floor Crossmember Assembly | | | | | | | | | |
| 7306-0830-124 | Small outer extrusion - right and left | \$1.01 | \$1.24 | \$2.28 | \$1.94 | \$0.32 | \$0.52 | \$0.09 | \$7.40 |
| 7306-0830-125 | Small floor crossmember - right and left | \$4.72 | \$12.12 | \$13.41 | \$14.02 | \$2.21 | \$3.54 | \$0.83 | \$50.84 |
| 7306-0830-126 | Small inner extrusion - right and left | \$1.01 | \$1.24 | \$2.28 | \$1.74 | \$0.31 | \$0.50 | \$0.09 | \$7.18 |
| Sub-total | | \$6.74 | \$14.59 | \$17.98 | \$17.70 | \$2.85 | \$4.56 | \$1.01 | \$65.42 |
| Large Floor Crossmember Assembly | | | | | | | | | |
| 7306-0840-010 | Large outer extrusion - right and left | \$0.47 | \$0.96 | \$1.25 | \$1.55 | \$0.21 | \$0.34 | \$0.07 | \$4.85 |
| 7306-0840-011 | Large floor crossmember - right and left | \$1.64 | \$4.58 | \$4.93 | \$6.12 | \$0.86 | \$1.38 | \$0.33 | \$19.83 |
| 7306-0840-012 | Large inner extrusion - right and left | \$0.47 | \$0.96 | \$1.25 | \$1.39 | \$0.20 | \$0.33 | \$0.07 | \$4.67 |
| 7306-0850-000 | Fore and aft extrusion - right and left | \$1.44 | \$5.08 | \$4.77 | \$5.47 | \$0.84 | \$1.34 | \$0.36 | \$19.30 |
| 7306-0860-000 | Center tunnel bracket | \$0.08 | \$0.12 | \$0.20 | \$1.83 | \$0.11 | \$0.18 | \$0.05 | \$2.57 |
| Sub-total | | \$4.10 | \$11.68 | \$12.41 | \$16.36 | \$2.23 | \$3.56 | \$0.88 | \$51.23 |
| Dash Panel | | | | | | | | | |
| 7305-1400-143 | Upper dash panel | \$0.55 | \$3.98 | \$3.10 | \$24.26 | \$1.59 | \$2.55 | \$0.00 | \$36.04 |
| 7305-1400-144 | Lower dash panel | \$0.96 | \$5.56 | \$4.57 | \$33.89 | \$2.25 | \$3.60 | \$0.00 | \$50.82 |
| 7305-1600-149 | Dash panel reinforcement | \$0.50 | \$3.31 | \$2.64 | \$18.42 | \$1.24 | \$1.99 | \$0.00 | \$28.10 |
| Sub-total | | \$2.01 | \$12.86 | \$10.31 | \$76.57 | \$5.09 | \$8.14 | \$0.00 | \$114.96 |
| Miscellaneous Panels and Reinforcements | | | | | | | | | |
| 7307-1600-183 | Rear wheelhouse outer panel - left | \$0.46 | \$2.64 | \$2.17 | \$12.70 | \$0.90 | \$1.44 | \$0.00 | \$20.31 |
| 7307-1600-184 | Rear wheelhouse outer panel - right | \$0.44 | \$2.35 | \$1.97 | \$11.38 | \$0.81 | \$1.29 | \$0.00 | \$18.24 |
| 7307-1600-213 | Rear closeout panel - left | \$0.03 | \$0.08 | \$0.09 | \$3.64 | \$0.19 | \$0.31 | \$0.08 | \$4.42 |
| 7307-1600-214 | Rear closeout panel - right | \$0.03 | \$0.08 | \$0.09 | \$3.64 | \$0.19 | \$0.31 | \$0.08 | \$4.42 |
| 7305-1500-157 | Shotgun inner panel - left | \$0.12 | \$0.34 | \$0.41 | \$8.91 | \$0.49 | \$0.78 | \$0.20 | \$11.25 |
| 7305-1500-158 | Shotgun inner panel - right | \$0.12 | \$0.34 | \$0.41 | \$8.91 | \$0.49 | \$0.78 | \$0.20 | \$11.25 |
| 7305-1500-197 | A-pillar inner reinforcement panel - left | \$0.02 | \$0.07 | \$0.07 | \$1.73 | \$0.09 | \$0.15 | \$0.04 | \$2.17 |
| 7305-1500-198 | A-pillar inner reinforcement panel - right | \$0.02 | \$0.07 | \$0.07 | \$1.73 | \$0.09 | \$0.15 | \$0.04 | \$2.17 |
| 7305-1400-154 | Lower A-pillar inner - right | \$0.10 | \$0.12 | \$0.24 | \$4.60 | \$0.25 | \$0.40 | \$0.10 | \$5.81 |
| 7305-1400-153 | Lower A-pillar inner - left | \$0.10 | \$0.12 | \$0.24 | \$4.60 | \$0.25 | \$0.40 | \$0.10 | \$5.81 |
| 7307-1400-164 | Rear wheelhouse inner - right | \$0.14 | \$0.42 | \$0.49 | \$35.63 | \$1.83 | \$2.93 | \$0.81 | \$42.26 |
| 7307-1400-163 | Rear wheelhouse inner - left | \$0.14 | \$0.42 | \$0.48 | \$35.63 | \$1.83 | \$2.93 | \$0.81 | \$42.24 |
| 7305-1500-228 | Lower A-pillar inner reinforcement - right | \$0.02 | \$0.05 | \$0.07 | \$0.92 | \$0.05 | \$0.08 | \$0.02 | \$1.21 |
| 7305-1500-227 | Lower A-pillar inner reinforcement - left | \$0.02 | \$0.05 | \$0.07 | \$0.92 | \$0.05 | \$0.08 | \$0.02 | \$1.21 |



LOTUS ARB LWV PROGRAM

| | | | | | | | | | |
|---------------|-----------------------------------|----------------|-----------------|-----------------|-------------------|----------------|-----------------|----------------|-------------------|
| 7307-1500-168 | Shock tower reinforcement - right | \$0.12 | \$0.12 | \$0.28 | \$4.44 | \$0.25 | \$0.40 | \$0.10 | \$5.70 |
| 7307-1500-167 | Shock tower reinforcement - left | \$0.12 | \$0.12 | \$0.28 | \$4.44 | \$0.25 | \$0.40 | \$0.10 | \$5.70 |
| 7305-1300-156 | Upper A-pillar inner - right | \$0.10 | \$0.14 | \$0.25 | \$8.14 | \$0.43 | \$0.69 | \$0.18 | \$9.94 |
| 7305-1300-155 | Upper A-pillar inner - left | \$0.10 | \$0.14 | \$0.25 | \$8.14 | \$0.43 | \$0.69 | \$0.18 | \$9.94 |
| 7305-1300-166 | Rear shock tower - right | \$0.53 | \$2.47 | \$2.11 | \$6.53 | \$0.58 | \$0.93 | \$0.00 | \$13.16 |
| 7305-1300-165 | Rear shock tower - left | \$0.53 | \$2.47 | \$2.11 | \$6.53 | \$0.58 | \$0.93 | \$0.00 | \$13.16 |
| 7306-0820-124 | Rocker sill extension - right | \$1.49 | \$5.39 | \$5.42 | \$17.28 | \$1.48 | \$2.37 | \$0.63 | \$34.05 |
| 7306-0810-123 | Rocker sill extension - left | \$1.49 | \$5.39 | \$5.42 | \$17.28 | \$1.48 | \$2.37 | \$0.63 | \$34.05 |
| | Sub-total | \$6.23 | \$23.37 | \$23.01 | \$207.70 | \$13.02 | \$20.83 | \$4.35 | \$298.51 |
| | Totals | \$37.71 | \$138.62 | \$135.63 | \$1,260.63 | \$78.63 | \$125.81 | \$25.01 | \$1,802.01 |

7.1.1. Appendix D: Intellicosting Methodology

Intellicosting Process Steps:

Component Cost Analysis:

- Photograph and weigh total component or assembly
- Disassemble component and create Bill of Material structure
- Weigh and photograph individual parts
- Allocated components to cost analysts:
 - Mechanical: Plastic/Die Castings
 - Electronics: PCB/Sensors/Cameras
- Cost analysts will enter physical dimension and manufacturing location data into Intellicosting Cost modeling application
- Cost modeling (high-level) description:
 - **Plastic example:**
 - Cost analyst will determine material type
 - Part dimensions (wall thickness/overall projected area) will be entered into cost model
 - Production volume and manufacturing region will be entered into cost model
 - Cost analyst will select correct tonnage of machine to efficiently produce component
 - Machine level data resident in cost model (portion):
 - Machine cost
 - Machine installation costs
 - Cycle times
 - Efficiencies
 - # or % of operator required to man machine
 - Amount of regrind material
 - Manual or automate part handling
 - Cost analyst will determine the size of facility required to produce part based on entire manufacturing process
 - The cost model will analyze all the inputs and create a final report that will include:
 - Operational step, such as Op 10 Melting
 - Machine description: Name / Tonnage

- Geographic region: State or Country
- Cycle times
- Fixed/Variable costs
- Total costs for each Operational step and entire assembly
- Cost analyst will determine tooling requirement for component
- **Electronics:**
 - Cost Analyst will photograph and weigh printed circuit board
 - Cost Analyst will determine board population methodology
 - Cost Analyst will review type and functions of components
 - Cost Analyst will research costs for components based on volume and purchasing power
 - Cost Analyst will de-laminate integrated circuits to review silicone die, to determine die manufacturing yield rate.
 - Cost analyst will create virtual production line equipment:
 - Chip placement (shooters)
 - Component feeders
 - Soldering process
 - In-Line testing
 - End of line testing
 - Cost Analyst will determine Engineering Design and Development cost associate with each functional group required to develop Print Circuit Board over a determined period of time (ex: 4 years)
 - Facility size and manpower requirements are entered into cost model
 - Cost analyst will review preliminary final report with Quality Peer Review team
 - Upon approval Cost Analyst will submit Final Report to Client