

DRAFT – 3/18/2020

METHOD 310

**Determination of Volatile Organic Compounds (VOC) in
Consumer Products and Reactive Organic Compounds
(ROC) in Aerosol Coating Products**

(Including Appendix A)

Adopted: September 25, 1997

Amended: September 3, 1999

Amended: July 18, 2001

Amended: May 5, 2005

Amended: August 6, 2010

Amended: September 29, 2011

Amended: August 1, 2014

Amended: [TBD, follow OAL approval]

Amended: [PROPOSED CHANGES for 2020]

DRAFT – 3/18/2020

DRAFT – 3/18/2020

METHOD 310

DETERMINATION OF VOLATILE ORGANIC COMPOUNDS (VOC) IN CONSUMER PRODUCTS AND REACTIVE ORGANIC COMPOUNDS (ROC) IN AEROSOL COATING PRODUCTS

(Including Appendix A)

1 APPLICABILITY

1.1 This method (Method 310) applies to the determination of the percent by weight of:

(1) volatile organic compounds (VOC) in consumer products, ~~antiperspirant and deodorant products, as that term is~~ those terms are defined in Title 17, California Code of Regulations (CCR), Division 3, Chapter 1, Subchapter 8.5 Consumer Products (Consumer Products Regulations) (Consumer Products), commencing with Article 1, sections 94500 and Article 2, 94508, and

(2) ~~low vapor pressure volatile organic compounds (LVP-VOC), as that term is defined in the Consumer Products Regulation, Article 2, section 94508(a), and~~

(3) ~~volatile components of a product that do not meet the definition of a VOC or are exempted, per the Consumer Products Regulations, Article 1, sections 94501 and 94503; and Article 2, 94508 and 94510, and~~

(4) ~~specific components that are prohibited, per the Consumer Products Regulation, Article 2, section 94509, and~~

(5) ~~reactive organic compound (ROC), as that term is defined in the Consumer Products Regulations, Article 2, 94509; and Article 3, section 94520, for the purposes of calculating product weighted maximum incremental reactivity (PWMIR).~~

1.2 ~~Method 310 applies to the determination of product weighted maximum incremental reactivity (PWMIR) of aerosol coating products, as that term is defined in Title 17, CCR, Consumer Products section 94521.~~

1.3 ~~Method 310 determines the total volatile material in a product and the presence of any compounds prohibited by CARB regulations (“prohibited compounds”). Components of the product that do not meet the definition of a VOC or are exempted by CARB regulations for a specific product category (“exempt compounds”) are subtracted from the total volatile material to determine the final VOC content for the product. Method 310 is also used to determine the percent by weight of the reactive organic compounds (ROC).~~

DRAFT – 3/18/2020

4.41.2 Method 310 does not apply to the determination of the composition or concentration of fragrance components in products.

4.51.3 The term “Executive Officer” as used in this document means the Executive Officer of the California Air Resources Board (CARB) or ~~their~~his or her authorized representative.

2 REFERENCES METHODS

2.1 Reference Methods

Method 310 incorporates by reference the following ASTM International (ASTM), National Institute for Occupational Safety and Health (NIOSH), and United States Environmental Protection Agency (US EPA) analytical test methods:

2.1.1 ASTM D86-01, Standard Test Method for Distillation of Petroleum Products at Atmospheric Pressure (August 10, 2001).

2.1.2 ASTM D523-08, Standard Test Method for Specular Gloss (June 1, 2008).

2.1.3 ASTM D850-00, Standard Test Method for Distillation of Industrial Aromatic Hydrocarbons and Related Materials (December 10, 2000).

2.1.4 ASTM D859-00, Standard Test Method for Silica in Water (June 10, 2000).

2.1.5 ASTM D1078-01, Standard Test Method for Distillation Range of Volatile Organic Liquids (June 10, 2001).

2.1.6 ASTM D1426-98, Standard Test Methods for Ammonia Nitrogen in Water (December 10, 1998).

2.1.7 ASTM D1613-06, Standard Test Method for Acidity in Volatile Solvents and Chemical Intermediates Used in Paint, Varnish, Lacquer, and Related Products (April 1, 2006).

2.1.8 ASTM D2369-01, Standard Test Method for Volatile Content of Coatings (January 10, 2001).

2.1.9 ASTM D2879-97, Standard Test Method for Vapor Pressure-Temperature Relationship and Initial Decomposition Temperature of Liquids by Isoteniscope (April 10, 1997).

2.1.10 ASTM D2887-01, Standard Test Method for Boiling Range Distribution of Petroleum Fractions by Gas Chromatography (May 10, 2001).

DRAFT – 3/18/2020

- 2.1.11 ASTM D3063-94, Standard Test Method for Pressure in Glass Aerosol Bottles (November 15, 1994), with the modifications found in Appendix A to this Method 310.
- 2.1.12 ASTM D3064-97, Standard Terminology Relating to Aerosol Products (September 10, 1997).
- 2.1.13 ASTM D3074-94, Standard Test Methods for Pressure in Metal Aerosol Containers (November 15, 1994), with the modifications found in Appendix A to this Method 310.
- 2.1.14 ASTM D3257-06, Standard Test Methods for Aromatics in Mineral Spirits by Gas Chromatography (April 1, 2006).
- 2.1.15 ASTM D3606-07, Standard Test Method for Determination of Benzene and Toluene in Finished Motor and Aviation Gasoline by Gas Chromatography (November 1, 2007).
- 2.1.16 ASTM D3792-99, Standard Test Method for Water Content of Coatings by Direct Injection Into a Gas Chromatograph (May 10, 1999).
- 2.1.17 ASTM D4017-96a, Standard Test Method for Water in Paints and Paint Materials by the Karl Fisher Method (July 10, 1996).
- 2.1.18 ASTM D4057-12, Standard Practice for Manual Sampling of Petroleum and Petroleum Products (December 1, 2012).
- 2.1.19 ASTM D4177-16e1, Standard Practice for Automotive Sampling of Petroleum and Petroleum Products (October 1, 2016).
- 2.1.20 ASTM D4626-95(2015), Standard Practice for Calculation of Gas Chromatographic Response Factors (April 1, 2015).
- 2.1.21 ASTM D5381-93(2009), Standard Guide for X-Ray Fluorescence (XRF) Spectroscopy of Pigments and Extenders (February 1, 2009).
- 2.1.22 ASTM D5443-14, Standard Test Method for Paraffin, Naphthene, and Aromatic Hydrocarbon Type Analysis in Petroleum Distillates Through 200°C by Multi-Dimensional Gas Chromatography (June 15, 2014).
- 2.1.23 ASTM D5580-15, Standard Test Method for Determination of Benzene, Toluene, Ethylbenzene, p/m-Xylene, o-Xylene, C9 and Heavier Aromatics, and Total Aromatics in Finished Gasoline by Gas Chromatography (December 1, 2015).

DRAFT – 3/18/2020

- 2.1.24 ASTM D6730-01(2016), Standard Test Method for Determination of Individual Components in Spark Ignition Engine Fuels by 100-Metre Capillary (with Precolumn) High-Resolution Gas Chromatography (April 1, 2016).
- 2.1.25 ASTM E203-01, Standard Test Method for Water Using Volumetric Karl Fisher Titration (October 1, 2001).
- 2.1.26 ASTM E1719-97, Standard Test Method for Vapor Pressure of Liquids by Ebulliometry (March 10, 1997).
- 2.1.27 ASTM E1782-08, Standard Test Method for Determining Vapor Pressure by Thermal Analysis (March 1, 2008).
- 2.1.28 NIOSH Methods 1300, Ketones I, NIOSH Manual of Analytical Methods, Fourth Edition (August 15, 1994).
- 2.1.29 NIOSH Methods 1400, Alcohols I, NIOSH Manual of Analytical Methods, Fourth Edition (August 15, 1994).
- 2.1.30 NIOSH: Methods 1401, Alcohols II, NIOSH Manual of Analytical Methods, Fourth Edition (August 15, 1994).
- 2.1.31 NIOSH: Methods 1402, Alcohols III, NIOSH Manual of Analytical Methods, Fourth Edition (August 15, 1994).
- 2.1.32 NIOSH: Methods 1403, Alcohols IV, NIOSH Manual of Analytical Methods, Fourth Edition (March 15, 2003).
- 2.1.33 US EPA Method 18, Measurement of Gaseous Organic Compound Emissions by Gas Chromatography, Title 40 CFR Part 60, Appendix A (July 1, 1996).
- 2.1.34 US EPA Method 24, Determination of Volatile Matter Content, Water Content, Density, Volume Solids, and Weight Solids of Surface Coatings, Title 40 Code of Federal Regulations (CFR) Part 60, Appendix A (July 1, 1996).
- 2.1.35 US EPA Method 24A, Determination of Volatile Matter Content and Density of Printing Inks and Related Coatings, Title 40 CFR Part 60, Appendix A (July 1, 1994).
- 2.1.36 US EPA Method 300.7, Dissolved Sodium, Ammonium, Potassium, Magnesium, and Calcium in Wet Deposition by Chemically Suppressed Ion Chromatography, EPA Report # 600/4-86-024 (March 1, 1986).
- 2.1.37 US EPA Method 625, Base/Neutrals and Acids, Title 40 CFR 136 Appendix A, Method for Organic Chemical Analysis of Municipal and Industrial Wastewater (July 1, 2007).

DRAFT – 3/18/2020

- 2.1.38 US EPA Method 8240B, Revision 2, September 1994, Final Update IIA to the Third Edition of the Test Methods for Evaluating Solid Waste, Physical/Chemical Methods, Volatile Organic Compounds by Gas Chromatography/Mass Spectrometry (GC/MS), EPA publication SW-846.
- 2.1.39 US EPA Method 8260B, Revision 2, December 1996, Final Update III to the Third Edition of the Test Methods for Evaluating Solid Waste, Physical/Chemical Methods, Volatile Organic Compounds by Gas Chromatography/Mass Spectrometry (GC/MS), EPA publication SW-846.
- 2.1.40 US EPA Method 8270D, Revision 4, January 1998, Final Update IV to the Third Edition of the Test Methods for Evaluating Solid Waste, Physical/Chemical Methods, Semivolatile Organic Compounds by Gas Chromatography / Mass Spectroscopy (GC/MS), EPA publication SW-846.

2.2 Literature References

Method 310 incorporates by reference the following peer reviewed and published scientific literature source:

- 2.2.1 Project 801, Design Institute for Physical Properties (DIPPR) of the American Institute of Chemical Engineers (AIChE), 2018, and reproduced with permission of DIPPR/AIChE.

- ~~2.1 ASTM D2369-01, Standard Test Method for Volatile Content of Coatings (January 10, 2001).~~
- ~~2.2 ASTM D1426-98, Standard Test Methods for Ammonia Nitrogen in Water (December 10, 1998).~~
- ~~2.3 ASTM D4017-96a, Standard Test Method for Water in Paints and Paint Materials by the Karl Fisher Method (July 10, 1996).~~
- ~~2.4 ASTM D3792-99, Standard Test Method for Water Content of Coatings by Direct Injection Into a Gas Chromatograph (May 10, 1999).~~
- ~~2.5 ASTM D859-00, Standard Test Method for Silica in Water (June 10, 2000).~~
- ~~2.6 ASTM D3074-94, Standard Test Methods for Pressure in Metal Aerosol Containers (November 15, 1994), with the modifications found in Appendix A to this Method 310.~~
- ~~2.7 ASTM D3063-94, Standard Test Method for Pressure in Glass Aerosol Bottles (November 15, 1994), with the modifications found in Appendix A to this Method 310.~~

DRAFT – 3/18/2020

- ~~2.8 — ASTM D3064-97, Standard Terminology Relating to Aerosol Products (September 10, 1997).~~
- ~~2.9 — NIOSH Methods 1400, Alcohols I, NIOSH Manual of Analytical Methods, Fourth Edition, (August 1994).~~
- ~~2.10 — US EPA Method 8240B, Revision 2, September 1994, Final Update IIA to the Third Edition of the Test Methods for Evaluating Solid Waste, Physical/Chemical Methods, Volatile Organic Compounds by Gas Chromatography/Mass Spectrometry (GC/MS), EPA publication SW-846.~~
- ~~2.11 — US EPA Method 8260B, Revision 2, December 1996, Final Update III to the Third Edition of the Test Methods for Evaluating Solid Waste, Physical/Chemical Methods, Volatile Organic Compounds by Gas Chromatography/Mass Spectrometry (GC/MS), EPA publication SW-846.~~
- ~~2.12 — US EPA Method 24, Determination of Volatile Matter Content, Water Content, Density, Volume Solids, and Weight Solids of Surface Coatings, Title 40 Code of Federal Regulations (CFR) Part 60, Appendix A, (July 1, 1996).~~
- ~~2.13 — US EPA Method 24A, Determination of Volatile Matter Content and Density of Printing Inks and Related Coatings, Title 40 CFR Part 60, Appendix A, (July 1, 1994).~~
- ~~2.14 — US EPA Method 18, Measurement of Gaseous Organic Compound Emissions by Gas Chromatography, Title 40 CFR Part 60, Appendix A, (July 1, 1996).~~
- ~~2.15 — US EPA Method 300.7, Dissolved Sodium, Ammonium, Potassium, Magnesium, and Calcium in Wet Deposition by Chemically Suppressed Ion Chromatography, EPA Report # 600/4-86-024, (March 1, 1986).~~
- ~~2.16 — ASTM D86-01, Standard Test Method for Distillation of Petroleum Products at Atmospheric Pressure (August 10, 2001).~~
- ~~2.17 — ASTM D850-00, Standard Test Method for Distillation of Industrial Aromatic Hydrocarbons and Related Materials (December 10, 2000).~~
- ~~2.18 — ASTM D1078-01, Standard Test Method for Distillation Range of Volatile Organic Liquids (June 10, 2001).~~
- ~~2.19 — ASTM D2879-97, Standard Test Method for Vapor Pressure Temperature Relationship and Initial Decomposition Temperature of Liquids by Isoteniscope (April 10, 1997).~~
- ~~2.20 — ASTM D2887-01, Standard Test Method for Boiling Range Distribution of Petroleum Fractions by Gas Chromatography (May 10, 2001).~~
- ~~2.21 — ASTM E1719-97, Standard Test Method for Vapor Pressure of Liquids by Ebulliometry (March 10, 1997).~~

DRAFT – 3/18/2020

- ~~2.22 ASTM D3257-06, Standard Test Methods for Aromatics in Mineral Spirits by Gas Chromatography (April 1, 2006).~~
- ~~2.23 ASTM D3606-07, Standard Test Method for Determination of Benzene and Toluene in Finished Motor and Aviation Gasoline by Gas Chromatography (November 1, 2007).~~
- ~~2.24 ASTM D3710-95(2004), Standard Test Method for Boiling Range Distribution of Gasoline and Gasoline Fractions by Gas Chromatography (November 1, 2004).~~
- ~~2.25 ASTM D5443-04, Standard Test Method for Paraffin, Naphthene, and Aromatic Hydrocarbon Type Analysis in Petroleum Distillates Through 200°C by Multi-Dimensional Gas Chromatography (November 1, 2004).~~
- ~~2.26 ASTM D5580-02(2007), Standard Test Method for Determination of Benzene, Toluene, Ethylbenzene, p/m-Xylene, o-Xylene, C9 and Heavier Aromatics, and Total Aromatics in Finished Gasoline by Gas Chromatography (November 1, 2007).~~
- ~~2.27 ASTM E1782-08, Standard Test Method for Determining Vapor Pressure by Thermal Analysis (March 1, 2008).~~
- ~~2.28 US EPA Method 602, Purgeable Aromatics, Title 40 CFR 136 Appendix A, Method for Organic Chemical Analysis of Municipal and Industrial Wastewater (July 1, 2007).~~
- ~~2.29 US EPA Method 625, Base/Neutrals and Acids, Title 40 CFR 136 Appendix A, Method for Organic Chemical Analysis of Municipal and Industrial Wastewater (July 1, 2007).~~
- ~~2.30 US EPA Method 8015B, Revision 2, December 1996, Final Update III to the Third Edition of the Test Methods for Evaluating Solid Waste, Physical/Chemical Methods, Non-Halogenated Organics Using GC/FID, EPA publication SW-846.~~
- ~~2.31 US EPA Method 8020A, Revision 1, September 1994, Final Update II to the Third Edition of the Test Methods for Evaluating Solid Waste, Physical/Chemical Methods, Aromatic Volatile Organics by Gas Chromatography, EPA publication SW-846.~~
- ~~2.32 US EPA Method 8270D, Revision 4, January 1998, Final Update IV to the Third Edition of the Test Methods for Evaluating Solid Waste, Physical/Chemical Methods, Semivolatile Organic Compounds by Gas Chromatography / Mass Spectroscopy (GC/MS), EPA publication SW-846.~~
- ~~2.33 ASTM D5381-93(2009), Standard Guide for X-Ray Fluorescence (XRF) Spectroscopy of Pigments and Extenders (February 1, 2009).~~
- ~~2.34 ASTM D523-08, Standard Test Method for Specular Gloss (June 1, 2008).~~

DRAFT – 3/18/2020

- ~~2.35 ASTM D1613-06, Standard Test Method for Acidity in Volatile Solvents and Chemical Intermediates Used in Paint, Varnish, Lacquer, and Related Products (April 1, 2006).~~
- ~~2.36 ASTM D6730-01(2016), Standard Test Method for Determination of Individual Components in Spark Ignition Engine Fuels by 100-Metre Capillary (with Precolumn) High-Resolution Gas Chromatography, (April 1, 2016).~~
- ~~2.37 ASTM D4057-12, Standard Practice for Manual Sampling of Petroleum and Petroleum Products, (December 1, 2012).~~
- ~~2.38 ASTM D4177-16e1, Standard Practice for Automotive Sampling of Petroleum and Petroleum Products, (October 1, 2016).~~
- ~~2.39 ASTM D4626-95(2015), Standard Practice for Calculation of Gas Chromatographic Response Factors, (April 1, 2015).~~
- ~~2.40 ASTM E203-01, Standard Test Method for Water Using Volumetric Karl Fisher Titration, (October 1, 2001).~~

3 TESTING TO DETERMINE VOC

3.1 Testing begins when the Executive Officer selects a product for analysis by Method 310. The Executive Officer will maintain sample chain of custody throughout the selection and analytical process.¹

3.2 Initial Testing of Aerosol Products

If the sample is an aerosol product, the aerosol propellant is separated from the non-propellant portion of the product using ASTM D3074-94 (as modified in Appendix A for metal aerosol container) or ASTM D3063-94 (as modified in Appendix A for glass aerosol container). The propellant portion is analyzed for ~~exempt or prohibited compounds by using US EPA Method 18.~~ The remaining non-propellant portion of the product is then analyzed as specified in section 3.3.

3.3 Initial Testing of Non-Aerosol Products and the Non-Propellant Portion of Aerosol Products

The non-aerosol product or non-propellant portion of an aerosol product is analyzed to determine the total VOC content~~volatile material~~ present in the sample and to determine the presence of any components that are exempt, or prohibited, or volatile but do not meet the definition of a VOC compounds. This analysis is conducted by performing the following tests:⁴

¹ Alternative test methods may be used, as provided in Section 8.

⁴ Alternate test methods may be used, as provided in section 7.0.

DRAFT – 3/18/2020

- 3.3.1 ~~Gravimetric analysis of samples to determine the weight percent of t~~Total VOC content volatile material determination, using one or more of the following: US EPA Method 24, US EPA Method 24A, ASTM D2369-01.
- 3.3.2 ~~Determination of sample w~~Water content. For determination, using of water content either ASTM D4017-96a (including ASTM E203-01), or ASTM D3792-99 ~~may be used~~, or results from both procedures may be averaged and that value reported.
- 3.3.3 ~~Determination of a~~Ammonium content determination, using ASTM D1426-98 or US EPA Method 300.7.
- 3.3.4 ~~Determination of k~~Ketones and alcohol content determination, using one or more of the following: NIOSH Method 1300, NIOSH Method 1400, NIOSH Method 1401, NIOSH Method 1402, and NIOSH Method 1403.
- 3.3.5 ~~Analysis of e~~Exempt and/or prohibited compounds content determination, if present, using one or more of the following: (US EPA Method 18, US EPA Method 8240B, US EPA Method 8260B, ASTM D859-00, NIOSH Method 1400). Effective January 1, 2015, for non-aerosol “Multi-purpose Solvent” and “Paint Thinner” products sold, supplied, offered for sale, or manufactured for sale in the South Coast Air Quality Management District, analysis of exempt and prohibited compounds shall include analysis for methyl esters with 17 or more carbon atoms, if present.
- 3.3.6 ~~h~~LVP-VOC content determination, as defined in the Consumer Products Regulation, Article 2, section 94508. If an LVP-VOC status is claimed or the analysis indicates the presence of an LVP-VOC component and the percent VOC is not in compliance, the Executive Officer will request formulation data as specified in Section 3.4.2.
- 3.3.7 ~~For low level-VOC content samples, direct determination for products with low level VOC (<5%), using one or more of the following: US EPA Method 18, US EPA Method 8240B, US EPA Method 8260B, ASTM D859-00, NIOSH Method 1400, NIOSH Method 1401, NIOSH Method 1402, and NIOSH Method 1403.~~
- 3.3.8 ~~For h~~Hydrocarbon compound content determination, using one or more of the following: US EPA Method 602, US EPA SW-846 Method 8020A, US EPA Modified Method 8015, US EPA Method 625, US EPA Method SW-846 Method 8270D, ASTM D5443-14D5443-04, ASTM D3257-06, ASTM D3710-95, ASTM D3606-07, ASTM D5580-15D5580-02, ASTM D6730-01(2016), ASTM D4057-12, ASTM D4177-16e1, ASTM D4626-95(2015).
- 3.4 Initial Determination of VOC Content

DRAFT – 3/18/2020

The Executive Officer will determine the VOC content pursuant to sections 3.2 and 3.3. Only those components with concentrations equal to or greater than 0.1 percent by weight will be reported.

- 3.4.1 Using the appropriate ~~equation~~formula specified in section 4.0, the Executive Officer will make an initial determination of whether the product meets the applicable VOC standards specified in CARB regulations. If initial results show that the product does not meet the applicable VOC standards, the Executive Officer may perform additional testing to confirm the initial results.
- 3.4.2 If the results obtained under section 3.4.1 show that the product does not meet the applicable VOC standards, the Executive Officer ~~may~~will request the responsible party to supply product formulation data. The responsible party shall supply the requested information. Information submitted to the CARB Executive Officer may be claimed as confidential; such information will be handled in accordance with the confidentiality procedures specified in Title 17, CCR, Division 3, Chapter 1, Subchapter 4 (Disclosure of Public Records), sections 91000 to 91022.
- 3.4.3 If the information supplied by the responsible party shows that the product does not meet the applicable VOC standards, then the Executive Officer will take appropriate enforcement action.
- 3.4.4 If the responsible party fails to provide formulation data as specified in section 3.4.2, the initial determination of VOC content under this section 3.4 shall determine if the product is in compliance with the applicable VOC standards. This determination may be used to establish a violation of CARB regulations.
- 3.5 ~~Determination of the LVP-VOC content, as that term is defined in the Consumer Products Regulation, Article 2, section 94508~~status of compounds and mixtures. ~~This section does not apply to antiperspirants and deodorants or aerosol coating products. Effective January 1, 2015, this section also does not apply to non-aerosol "Multi-purpose Solvent" and "Paint Thinner" products sold, supplied, offered for sale, or manufactured for sale in the South Coast Air Quality Management District. There is no LVP-VOC exemption for these products.~~
- 3.5.1 Formulation data. If the vapor pressure ~~and/or boiling point are~~is unknown, the following ASTM methods, which are incorporated by reference herein, may be used to determine ~~the LVP-VOC content;~~status of compounds and mixtures: ~~ASTM D86-01 (August 10, 2001), ASTM D850-00 (December 10, 2000), ASTM D1078-01 (June 10, 2001), ASTM D2879-97 (April 10, 1997), ASTM D2887-01 (May 10, 2001), and ASTM E1719-97 (March 10, 1997).~~
- 3.5.1.1 Testing to determine the vapor pressure of a compound may be performed using one of the following ASTM methods: ASTM D2879-97, ASTM E1719-97, and ASTM E1782-08.

DRAFT – 3/18/2020

3.5.1.2 Testing to determine the boiling point of a consumer product may be performed using one of the following ASTM methods: ASTM D86-01, ASTM D850-00, ASTM D1078-01, and ASTM D2887-01.

3.5.2 ~~LVP-VOC determination of compounds or mixtures.~~ ~~status of “compounds” or “mixtures.”~~ The Executive Officer ~~may~~will ~~perform boiling point analysis, per ASTM 2887-01.~~ ~~test a sample of the LVP-VOC used in the product formulation to determine the boiling point for a compound or for a mixture.~~ ~~If the boiling point exceeds 216°C, the compound or mixture is an LVP-VOC.~~ ~~If the boiling point is less than 216°C, then the weight percent of the mixture which boils above 216°C is an LVP-VOC.~~ The Executive Officer will use the nearest 1 percent distillation cut that is greater than 216°C ~~as determined under 3.5.1~~ to determine the percentage of the mixture qualifying as an LVP-VOC.

3.6 Final Determination of VOC Content

If a product’s compliance status is not satisfactorily resolved under sections 3.4 and 3.5, the Executive Officer ~~may~~will conduct further analyses and testing as necessary to verify the formulation data.

3.6.1 If the accuracy of the supplied formulation data is verified and the product sample is determined to meet the applicable VOC standards, then no enforcement action for violation of the VOC standards will be taken.

3.6.2 If the Executive Officer is unable to verify the accuracy of the supplied formulation data, then the Executive Officer will request the responsible party to supply information to explain the discrepancy.

3.6.3 If there exists a discrepancy that cannot be resolved between the results of Method 310 and the supplied formulation data, then the results of Method 310 shall take precedence over the supplied formulation data. The results of Method 310 shall then determine if the product is in compliance with the applicable VOC standards, and may be used to establish a violation of CARB regulations.

4 CALCULATION OF VOC CONTENT

~~This section specifies the procedure for determining the final VOC content of a product, which is reported as percent by weight of VOC. Effective January 1, 2015, for non-aerosol “Multi-purpose Solvent” and “Paint Thinner” products sold, supplied, offered for sale, or manufactured for sale in the South Coast Air Quality Management District (SCAQMD) the final VOC content is reported as grams of VOC per liter of material (g/L) as set forth in section 4.2.4.~~

4.1 Article 1 Products

DRAFT – 3/18/2020

This section specifies the equations used for calculating the Medium Volatility Organic Compound (MVOC) and High Volatility Organic Compound (HVOC), as defined the Consumer Products Regulation, Article 1, sections 94501 and 94503, which are reported as percent by weight.

4.1.1 Aerosol Products

4.1.1.1 HVOC:

$$\% \text{ HVOC} = \left[\sum_{i=1}^h \left(\frac{\text{HV}}{\text{WL} + \text{WP}} \right)_i \right] \times 100$$

Where:

HV = weight of HVOC compound (g), in product.

WL = weight in grams (g) of a non-aerosol sample or the non-propellant portion of an aerosol sample, excluding container and packaging.

WP = weight (g) of propellant.

h = number of HVOC compounds identified.

4.1.1.2 MVOC:

$$\% \text{ MVOC} = \left[\sum_{i=1}^m \left(\frac{\text{MV}}{\text{WL} + \text{WP}} \right)_i \right] \times 100$$

Where:

MV = weight of MVOC compound (g), in products.

m = number of MVOC compounds identified.

4.1.2 Non-Aerosol Products

4.1.2.1 HVOC:

$$\% \text{ HVOC} = \left[\sum_{i=1}^h \left(\frac{\text{HV}}{\text{WL}} \right)_i \right] \times 100$$

4.1.2.2 MVOC:

DRAFT – 3/18/2020

$$\% \text{ MVOC} = \left[\sum_{i=1}^m \left(\frac{\text{MV}}{\text{WL}} \right)_i \right] \times 100$$

4.2 Article 2 Products

This section specifies the equations for calculating the VOC content, as defined in the Consumer Products Regulation, Article 2, sections 94508 and 94509, which are reported as percent by weight.

4.14.2.1 Aerosol Products

4.14.2.1.1 For aerosol products, except those containing LVP-VOC, the percent VOC content shall be calculated using the following equation:

$$\% \text{ VOC} = \frac{\text{WL} (\text{TV} - \text{A} - \text{H} - \text{EL}) + (\text{WP} - \text{EP})}{\text{WL} + \text{WP}} \times 100$$

$$\% \text{ VOC} = \left[\frac{\text{WL} (\text{TV} - \text{A} - \text{H} - \text{EL}) + (\text{WP} - \text{EP})}{\text{WL} + \text{WP}} \right] \times 100$$

Where²:

- WL = weight in grams (g), of a non-aerosol sample or the non-propellant portion of an aerosol sample, excluding container and packaging.
- TV = weight fraction of total volatile content material in a non-aerosol sample or in the non-propellant portion of an aerosol sample.
- A = weight fraction of ammonia (as NH_4^{\pm}) in a non-aerosol sample or in the non-propellant portion of an aerosol sample.
- H = weight fraction of water in a non-aerosol sample or in the non-propellant portion of an aerosol sample.
- EL = weight fraction of exempt compound(s) in a non-aerosol sample or in the non-propellant portion of an aerosol sample.
- WP = weight (g) of propellant.
- EP = weight (g) of exempt compound(s) compounds in propellant

DRAFT – 3/18/2020

4.1.24.2.1.2 For aerosol products containing LVP-VOC, the percent VOC shall be calculated using the following equation:

$$\% \text{ VOC} = \frac{WL [(1 - H) \times (1 - LVP) - EL] + (WP - EP)}{WL + WP} \times 100$$
$$\% \text{ VOC} = \left[\frac{WL [(1 - H) \times (1 - LVP) - EL] + (WP - EP)}{WL + WP} \right] \times 100$$

Where:

LVP = weight fraction of LVP-VOC compounds and/or mixtures in the non-propellant, non-aqueous portion.

~~1 - H = weight fraction of the non-propellant portion that does not contain water.~~

~~1 - LVP = weight fraction of the non-propellant, non-aqueous portion that is volatile.~~

² Alternate test methods, as provided in section 7.0.

4.24.2.2 Non-Aerosol Products

4.2.14.2.2.1 For non-aerosol products, except those containing LVP-VOC, the percent VOC content shall be calculated using the following equation:

$$\% \text{ VOC} = (TV - A - H - EL) \times 100$$

4.2.24.2.2.2 For non-aerosol products containing LVP-VOC, the percent VOC shall be calculated using the following equation:

$$\% \text{ VOC} = [(1 - H) \times (1 - LVP) - EL] \times 100$$

4.2.3 For consumer products with VOC embedded within a delivery substrate, for example Fabric Softener – Single Use Dryer Product, VOC is calculated as total weigh (g) VOC per use.~~the grams of VOC per sheet shall be calculated as follows:~~

4.2.3.1 For those products, except for those containing LVP-VOC:

$$\text{Total Grams VOC per Sheet} = (TV - A - H - EL) \times WS$$

$$\text{VOC per use (g)} = (TV - A - H - EL) \times TW$$

DRAFT – 3/18/2020

Where:

TW = total weight (g) of VOC and delivery substrate per use, excluding container and packaging.

4.2.3.2 For products containing LVP-VOC:

$$\text{VOC per use (g)} = [(1 - H) \times (1 - \text{LVP}) - \text{EL}] \times \text{TW}$$

$$\text{Total Grams VOC per Sheet with LVP} = [(1 - H) \times (1 - \text{LVP}) - \text{EL}] \times \text{WS}$$

Where:

WS = weight (g) of single dryer sheet.

4.2.4 Effective January 1, 2015, for non-aerosol “Multi-purpose Solvent” and “Paint Thinner” products sold, supplied, offered for sale, or manufactured for sale for use in the SCAQMD, grams of VOC per liter of material (g/L) shall be calculated using the following equation:

$$\text{g/L VOC} = \frac{\text{WM} \times (\text{TV} - \text{H} - \text{EL})}{\text{VM}}$$

Where:

WM = weight of the material in grams.

VM = volume of the material in liters.

EL = weight fraction of exempt compounds including the weight fraction of methyl esters with 17 or more carbon atoms in the total volatile material.

~~4.3.14.2.5~~ Consumer products subject to low VOC limits (~~below~~ 5.0%) may have their VOC content characterized by a low level direct determination.

~~4.3.14.2.5.1~~ For aerosol products the percent VOC content may be calculated using the following equation:

$$\% \text{ VOC} = \frac{\text{WL} [\sum V_n] + (\text{WP} - \text{EP})}{\text{WL} + \text{WP}} \times 100$$

DRAFT – 3/18/2020

$$\% \text{ VOC} = \left[\frac{\text{WL} \left(\sum_{i=1}^n V_i \right) + (\text{WP} - \text{EP})}{(\text{WL} + \text{WP})} \right] \times 100$$

Where:

- V = weight fraction of VOC compound~~non-exempted VOCs~~ in the non-propellant portion.
- n = number of VOC compounds~~non-exempted VOCs~~ in the non-propellant portion.

4.3.24.2.5.2 For non-aerosol products the percent VOC content shall be calculated using the following equation:

$$\% \text{ VOC} = \left(\sum_{i=1}^n V_i \right) \times 100$$

$$\% \text{ VOC} = \left[\sum V_n \right] \times 100$$

5 TESTING TO DETERMINE ROC

5.1 Testing begins when the Executive Officer selects a product for analysis. The Executive Officer will maintain sample chain of custody throughout the selection and analytical process. ~~When a product is selected for testing, the Executive Officer will request the responsible party to supply the product formulation data specified in Title 17, CCR, Consumer Products section 94526(b)(1). The responsible party shall supply the requested information within 25 working days. Information submitted to the Executive Officer may be claimed as confidential; such information will be handled in accordance with the confidentiality procedures specified in Title 17, CCR, Disclosure of Public Records sections 91000 to 91022.~~²

5.2 Initial Testing of Aerosol Products

If the sample is an aerosol product, the aerosol propellant is separated from the non-propellant portion of the product using ASTM D3074-94 (as modified in Appendix A for metal aerosol container) or ASTM D3063-94 (as modified in

² Alternative test methods may be used, as provided in Section 8.

³ ~~Alternate test methods may be used, as provided in section 7.0.~~

DRAFT – 3/18/2020

Appendix A for glass aerosol container). The propellant portion is analyzed for ROC(s)~~ROCs~~ and other compound(s)~~compounds~~ by using US EPA Method 18. The remaining non-propellant portion of the product is then analyzed as specified in section 5.3.

5.3 Initial Testing of Non-Aerosol Products or the Non-Propellant Portion of Aerosol Products

The non-aerosol product or non-propellant portion of the aerosol product is analyzed to determine the ROC(s) in the sample, including the presence of any prohibited compound(s)~~compounds~~. This analysis is conducted by performing the following tests:³

- 5.3.1 ~~Gravimetric analysis of samples to determine the weight percent of t~~Total volatile content~~material determination, using one or more of the following: US EPA Method 24, US EPA Method 24A, ASTM D2369-01.~~
- 5.3.2 ~~Determination of sample w~~Water content. For determination, using of water content either ASTM D4017-96a (including ASTM E203-01), or ASTM D3792-99 may be used, or results from both procedures may be averaged and that value reported.
- 5.3.3 ~~Determination of a~~Ammonium content determination, using ASTM D1426-98 or US EPA Method 300.7.
- 5.3.4 ~~Determination of k~~Ketones and alcohol content determination, using one or more of the following: NIOSH Method 1300, NIOSH Method 1400, NIOSH Method 1401, NIOSH Method 1402, and NIOSH Method 1403.
- 5.3.5 ~~Direct determination of ROC and, if present, p~~Prohibited component determination, if present, using one or more of the following: compounds (US EPA Method 18, US EPA Method 8240B, US EPA Method 8260B, ASTM D859-00, NIOSH Methods 1400, NIOSH Method 1401, NIOSH Method 1402, NIOSH Method 1403-1403, and modified-ASTM D5443-14D5443-04).
- 5.3.6 ~~Determination of metal content using ASTM D5381-93 (2009).~~
- 5.3.7 ~~Determination of specular gloss using ASTM D523-08 (2008).~~
- 5.3.8 ~~Determination of acid content using ASTM D1613-06 (2006).~~
- 5.3.9 ~~5.3.6 For h~~Hydrocarbon compound content determination using one or more of the following: ASTM D6730-01(2016), ASTM D4057-12, ASTM D4177-16e1, ASTM D4626-95(2015).

5.4 Initial Determination and Verification of ROC Content

DRAFT – 3/18/2020

The Executive Officer will determine the ROC content by verifying formulation data pursuant to sections 5.2 and 5.3. Only those components with concentrations equal to or greater than 0.1 percent by weight will be reported.

- 5.4.1 ~~Using the equation specified in section 6~~Based on formulation data and the analysis conducted under section 5, the Executive Officer will make an initial determination of whether the product meets the applicable requirements specified in CARB regulations. If initial results show that the product does not meet the applicable requirements, the Executive Officer may perform additional testing to confirm the initial results.
- 5.4.2 If the results obtained under section 5.4.1 show that the product does not meet the applicable limits set forth in the CARB regulations, the Executive Officer may request the responsible party to supply the product formulation data specified in section 94526. The responsible party shall supply the requested information. Information submitted to the Executive Officer may be claimed as confidential; such information will be handled in accordance with the confidentiality procedures specified in Title 17, CCR, Disclosure of Public Records sections 91000 to 91022.
- 5.4.3 If the information supplied by the responsible party shows that the product does not meet the applicable Reactivity Limit, then the Executive Officer will take appropriate enforcement action.
- 5.4.4 If the responsible party fails to provide formulation data as specified in section 5.4.2, the initial determination of ROC content under this section 5.4 shall determine if the product is in compliance with the applicable Reactivity Limit. This determination may be used to establish a violation of CARB regulations.

5.5 Final Determination of ROC Content

If a product's status is not satisfactorily resolved under section 5.1 - 5.4, the Executive Officer may conduct additional analyses and testing as necessary to verify the formulation data.

- 5.5.1 If the accuracy of the supplied formulation data is verified and the product sample is determined to meet the applicable Reactivity Limit, then no enforcement action for violation of the applicable standards will be taken.
- ~~5.5.1~~ 5.5.2 If the Executive Officer is unable to verify the accuracy of the supplied formulation data, then the Executive Officer will request the responsible party to supply additional information to explain the discrepancy.
- 5.5.2 ~~If the additional information supplied by the responsible party shows that the product does not meet the applicable requirements, then the Executive Officer will take appropriate enforcement action.~~

DRAFT – 3/18/2020

~~5.5.3~~ If the responsible party fails to provide additional information as specified in section 5.5.1, the initial determination of ROC content under section 5.1—5.4 shall determine if the product is in compliance with the applicable reactivity limits. This determination may be used to establish a violation of CARB regulations.

~~5.5.4~~ 5.5.3 If there exists a discrepancy that cannot be resolved between the results of Method 310 and the formulation data or additional information supplied by the responsible party, then the results of Method 310 shall take precedence over the supplied formulation data or additional information. The results of Method 310 shall then determine if the product is in compliance with the applicable requirements, and may be used to establish a violation of CARB regulations.

6 CALCULATION OF ROC CONTENT

ROC content is reported as Product-Weighted MIR (PWMIR) and calculated as follows:

$$\text{PWMIR} = \left[\sum_{i=1}^r \left(\frac{\text{RW}}{\text{WL} + \text{WP}} \right)_i \times \text{MIR}_i \right] \times 100$$

Where:

RW = weight of ROC compound (g) in products.

r = number of ROC compounds identified.

MIR = maximum incremental reactivity (MIR) value, as defined in section 94522.

WL = weight (g) of a non-aerosol sample or the non-propellant portion of an aerosol sample, excluding container and packaging.

WP = weight (g) of propellant.

6.7 METHOD PRECISION AND ACCURACY

6.7.1 The precision of Method 310 for determining VOC content was evaluated using seven representative products with known VOC contents ranging from 6.2 to 81.2 percent VOC by weight. Each sample was divided into six portions, and each portion was separately analyzed to determine the VOC content. Based on

DRAFT – 3/18/2020

the results of this analysis, the 95 percent confidence interval for Method 310 is 3.0 percent by weight.

6.27.2 For determining the percent by weight of the individual ingredients in aerosol coating products, the precision and accuracy of the determination for each ingredient is governed by the precision and accuracy of the test method used to ascertain the percent by weight of each ingredient.

78 ~~ALTERNATE~~ ALTERNATIVE TEST METHODS

Alternative test methods ~~which are shown to accurately determine the concentration of VOC or components in antiperspirant/deodorants, consumer products, or aerosol coating products (or their emissions)~~ may be used upon written approval of the Executive Officer, as described in the Consumer Products Regulations, sections 94506, 94515 and 94526, respectively.

DRAFT – 3/18/2020

Method 310 - Appendix A

PROPELLANT COLLECTION PROCEDURES

1 APPLICATION

The procedure applies to modify ASTM D3074-94 and D3063-94 to allow collection of the propellant for analysis and density measurement for metal aerosol containers and glass aerosol containers, respectively. These modified procedures also retain the aerosol standard terminology listed in ASTM D3064-97.

2 LIMITATIONS

Nitrogen analysis: Nitrogen may be used as a component of the propellant system. Ambient air is 78 percent nitrogen and may be present as a contaminant in the system prior to sample collection. This is eliminated by sweeping out any connecting lines to the propellant collection bag with product before starting sample collection. This procedure will eliminate or reduce nitrogen contamination to less than 0.1 percent by weight of the sample and the analysis of the propellant gas will be unaffected.

3 EQUIPMENT AND SUPPLIES~~APPARATUS AND MATERIALS~~

- 3.1 Propellant Collection System: See Figure 1 (metal containers) and Figure 3 (glass containers).
- 3.2 Propellant Collection Bags equipped with slip valve and septum.
- 3.3 Density Measurement
 - 3.3.1 250 mL gas dilution bulb, or
 - 3.3.2 Density/Specific gravity meter meeting the following minimum specifications:
 - 3.3.2.1 Measurement Range: 0 – 3 +/- 0.00001 g/cm³
 - 3.3.2.2 Measurement Temperature Range: 4°C ~ 70°C.
- 3.4 Balance, capable of accurately weighing to 0.1 mg
- 3.5 Sample Venting Platform. See Figure 2¹ (metal containers) and Figure 4² (glass containers).

¹ See SOP SAS05, Figures 3 and 4.

² See SOP SAS05, Figure 7.

DRAFT – 3/18/2020

3.6 Platform Shaker, equivalent to Thermolyne M49125

3.7 Cork Rings, 80 x 32 mm

4 PROCEDURE

4.1 Propellant Collection for Metal Aerosol Containers

4.1.1 Close valves on Propellant Collection System (see Figure 1).

4.1.2 Remove the actuator from valve on the aerosol can and weigh can to the nearest 0.01 g.

4.1.3 Place the can in an inverted position onto the Sample Venting Platform, stabilized by cork rings.

4.1.4 Slowly raise the hydraulic jack until the can is pierced.

4.1.5 Vent the can until propellant is seen flowing from output 1. Collect the propellant in the propellant collection bag from output 1. Density is determined from this same propellant collection bag, as necessary.

4.1.6 After the propellant is collected, close and remove the propellant collection bag and vent the remainder of the propellant.

4.1.7 After the flow ceases from the can, it is removed from the assembly and allowed to vent overnight on a platform shaker, to vent the remainder of the propellant.

4.1.8 Reweigh the can to the nearest 0.01 g and record weight loss (total grams propellant). The can may now be opened for analysis of the non-propellant portion of the sample.

4.2 Propellant Collection for Glass Aerosol Containers

4.2.1 Remove the actuator from valve of the aerosol glass container and weigh container to the nearest 0.01 g.

4.2.2 With container in an inverted position place the valve onto the tapered adaptor.

4.2.3 Pressurize the air cylinder to actuate the sample container valve onto the tapered adaptor.

4.2.4 Open the sample valve and collect propellant sample into the propellant collection bag. Density is determined from this same propellant collection bag, as necessary.

DRAFT – 3/18/2020

- 4.2.5 After the propellant is collected, close and remove the propellant collection bag and vent the remainder of the propellant.
- 4.2.6 Continue to vent the container on the platform assembly until no pressure registers on the sample gauge and there is no visible propellant flowing from the sampling tube.
- 4.2.7 Remove the container from the platform.
- 4.2.8 Punch a small hole into the container valve assembly.
- 4.2.9 Place the container on a platform shaker to vent the remainder of the propellant.
- 4.2.10 Reweigh the container and valve assembly to the nearest 0.01 g and record weight loss (total grams propellant). The non-propellant portion of the sample is ready to be analyzed.

DRAFT – 3/18/2020

FIGURE 1

PROPELLANT COLLECTION SYSTEM

METAL AEROSOL CONTAINER

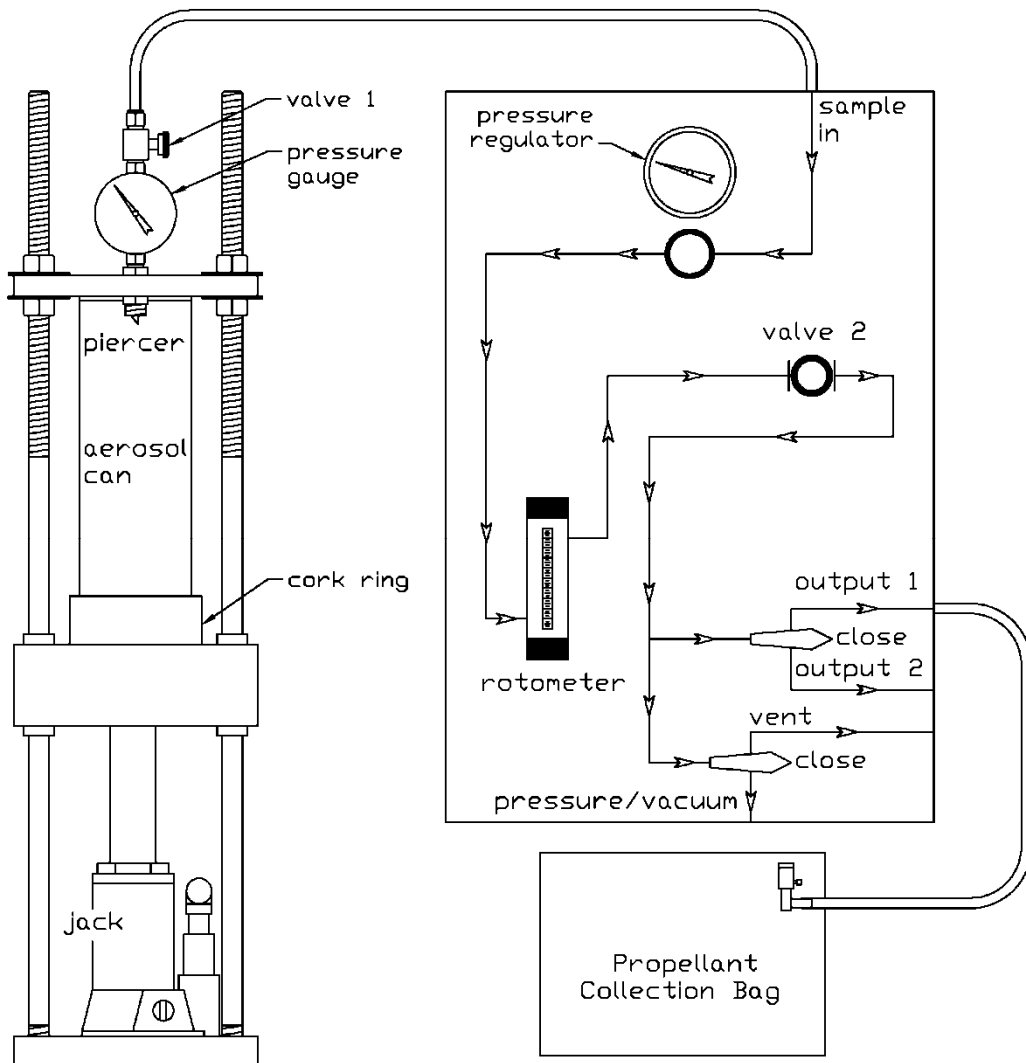

DRAFT – 3/18/2020

FIGURE 2

SAMPLE VENTING PLATFORM METAL AEROSOL CONTAINER

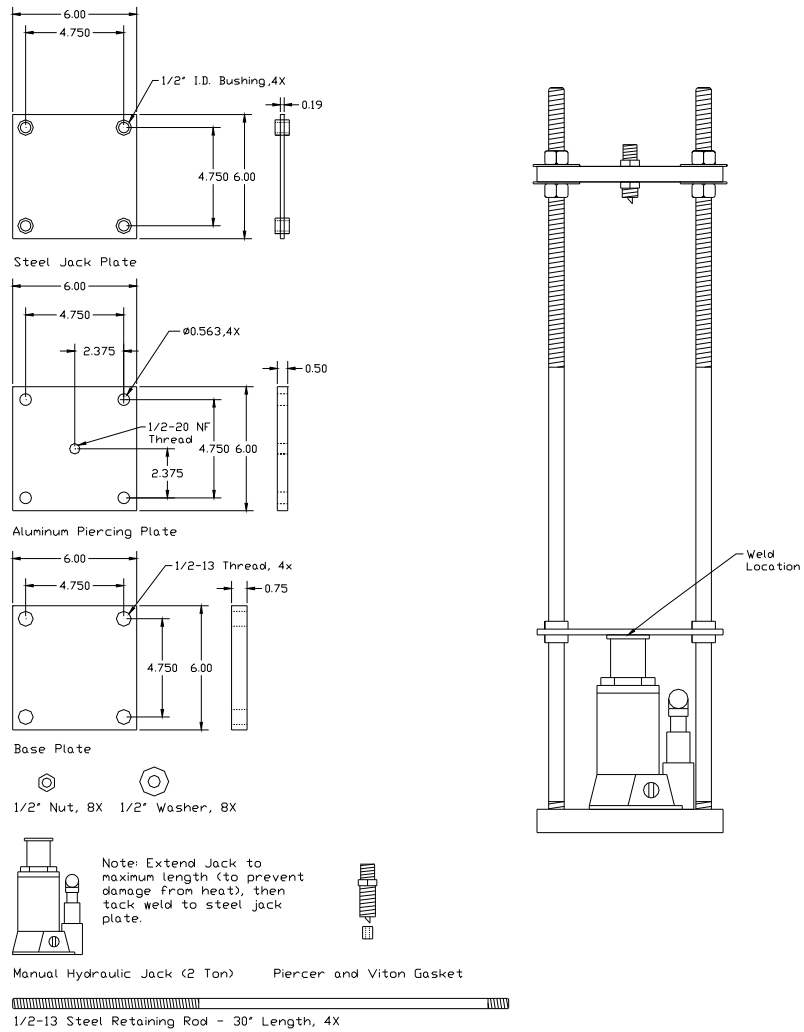

DRAFT – 3/18/2020

FIGURE 3

PROPELLANT COLLECTION SYSTEM

GLASS AEROSOL CONTAINER

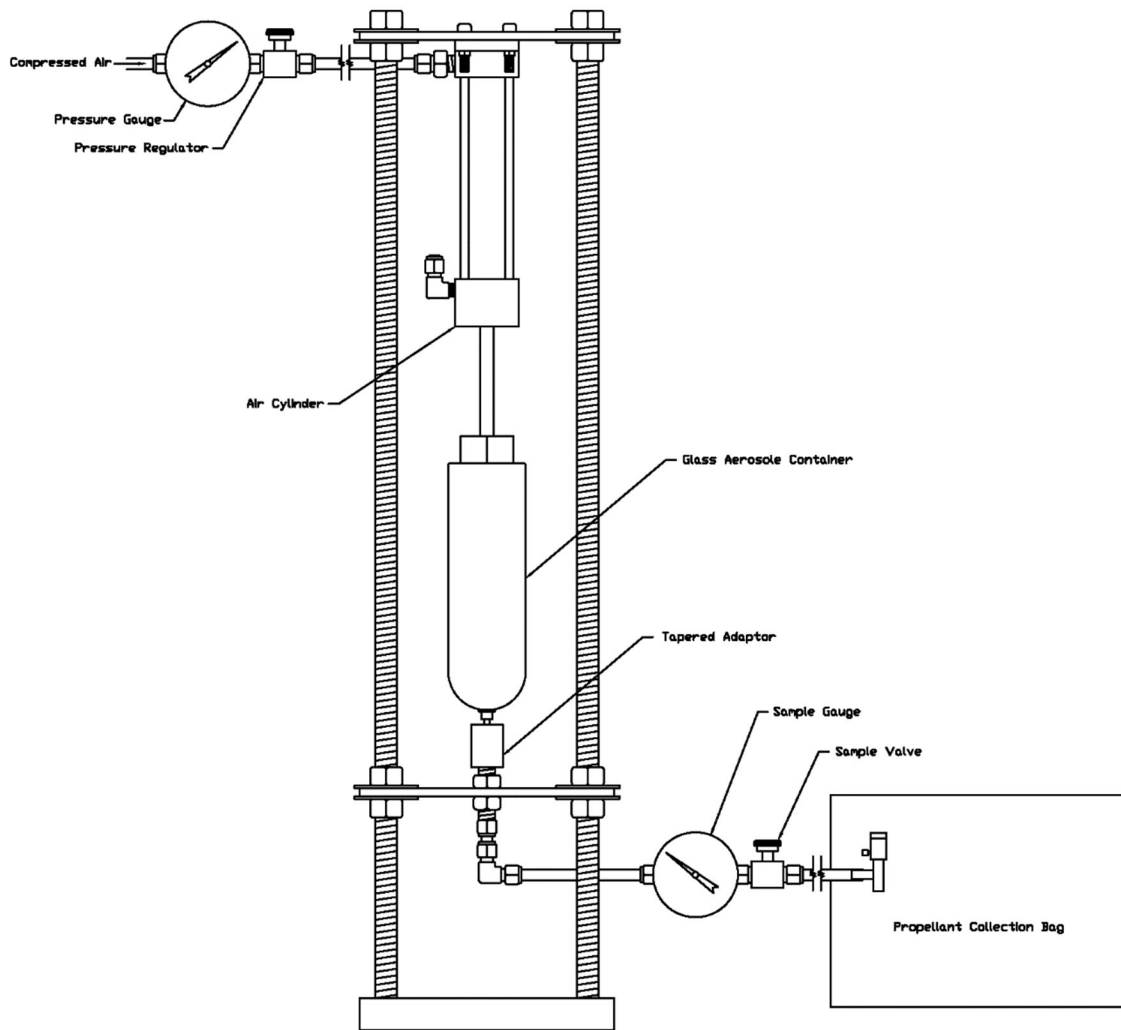

DRAFT – 3/18/2020

FIGURE 4

SAMPLE VENTING PLATFORM
GLASS AEROSOL CONTAINER

