

State of California
AIR RESOURCES BOARD

**SPECIFICATIONS FOR FILL PIPES AND OPENINGS OF
2015 AND SUBSEQUENT MODEL MOTOR VEHICLE FUEL TANKS**

Adopted: March 22, 2012
Amended: May 31, 2019

NOTE: This document is incorporated by reference in section 2235, title 13, California Code of Regulations (CCR). Additional requirements necessary to complete an application for certification of motor vehicles are contained in other documents that are designed to be used in conjunction with this document. These other documents include:

1. "California 2015 and Subsequent Model Criteria Pollutant Exhaust Emission Standards and Test Procedures and 2017 and Subsequent Model Greenhouse Gas Exhaust Emission Standards and Test Procedures for Passenger Cars, Light-Duty Trucks and Medium-Duty Vehicles" (incorporated by reference in section 1961.2 (d), title 13, CCR);
2. "California Exhaust Emission Standards and Test Procedures for 2009 and Subsequent Model Zero-Emission Vehicles and Hybrid Electric Vehicles, in the Passenger Car, Light-Duty Truck, and Medium-Duty Vehicle Classes" (incorporated by reference in section 1962.1(h), title 13, CCR);
3. "California Evaporative Emission Standards and Test Procedures for 2001 and Subsequent Model Motor Vehicles" (incorporated by reference in section 1976(c), title 13, CCR);
4. "Malfunction and Diagnostic System Requirements – 1994 and Subsequent Model-Year Passenger Cars, Light-Duty Trucks, and Medium-Duty Vehicles and Engines" (incorporated by reference in section 1968.1, title 13, CCR);
5. "Malfunction and Diagnostic System Requirements – 2004 and Subsequent Model-Year Passenger Cars, Light-Duty Trucks, and Medium-Duty Vehicles and Engines" (incorporated by reference in section 1968.2, title 13, CCR);
6. "California Refueling Emission Standards and Test Procedures for 2001 and Subsequent Model Motor Vehicles" (incorporated by reference in section 1978, title 13, CCR).

SPECIFICATIONS FOR FILL PIPES AND OPENINGS OF MOTOR VEHICLE FUEL TANKS

I. General

A. No new 2015 or later model year gasoline or alcohol fueled passenger car, light-duty truck, medium-duty vehicle, or heavy-duty vehicle may be sold, offered for sale, or registered in California unless such vehicle complies with the following specifications for fill pipes and openings of motor vehicles fuel tanks. The Executive Officer may exempt vehicles for which compliance with the specifications is found to be technologically infeasible, in accordance with Section XI.

B. Evidence to show compliance with these specifications shall be submitted to the Executive Officer of the Air Resources Board with the application of certification of new vehicles required by Chapter 3, Subchapter 1, Article 2, of Title 13 of the California Code of Regulations.

C. Sections IV through XII shall apply to new 2015 and later model year otto-cycle motor vehicles, except motorcycles.

II. Definitions

These test procedures incorporate by reference the definitions set forth in the International Organization for Standardization standard (ISO) "Road vehicles – Filler pipes and openings of motor vehicle fuel tanks – Vapour recovery system" (ISO-13331-1995(E)), as adopted June 1, 1995; the "California 2015 and Subsequent Model Criteria Pollutant Exhaust Emission Standards and Test Procedures and 2017 and Subsequent Model Greenhouse Gas Exhaust Emission Standards and Test Procedures for Passenger Cars, Light-Duty Trucks and Medium-Duty Vehicles;" and the "California Exhaust Emission Standards and Test Procedures for 2009 and Subsequent Model Zero-Emission Vehicles and Hybrid Electric Vehicles, in the Passenger Car, Light-Duty Truck, and Medium-Duty Vehicle Classes," including the incorporated definitions from the Code of Federal Regulations. In addition, the following definitions apply:

A. "Restriction device" means a fill pipe device installed by the vehicle manufacturer to prevent insertion by a leaded nozzle spout and to prevent fueling with leaded gasoline, pursuant to regulations of the United States Environmental Protection Agency.

B. "Vapor recovery nozzle", for the purpose of these specifications, means a nozzle, as appropriate for fueling vehicles, certified by the state board, pursuant to the latest version of the board's "CP-201 Certification Procedure for Vapor Recovery Systems at Gasoline Dispensing Facilities" established in Section 94011 of Title 17, California Code of Regulations together with an appropriate vapor hose.

- C. "Premature nozzle shut-off" means any automatic shut-off of the vapor recovery nozzle before the vehicle fuel tank is filled to either 90 percent of the nominal fuel tank capacity or to within two gallons less than the nominal tank capacity, whichever corresponds to the smaller quantity of gasoline in the fuel tank.
- D. "Liquid gasoline loss" means any liquid gasoline that leaves the fill pipe/nozzle interface during dispersing or after nozzle shut-off and includes any liquid gasoline on the ground, on the vehicle, or that enters the nozzle bellows, nozzle body vapor passage, or vapor hose, but does not include liquid gasoline in the nozzle spout.
- E. "Fill pipe head" means upper portion of the fill pipe which would interface with the vapor recovery nozzle during refueling. The following fill pipe characteristics shall be the same among fill pipe heads sharing the same design:
 - 1. The exterior of the fill pipe from the sealing surface to a plane perpendicular to the fill pipe centerline that is located 12 mm beyond the sealing surface. Fill pipe sealing surface is defined in III.A.a.
 - 2. The internal locking lip depth from the sealing surface.
 - 3. The fill pipe outer diameter.
 - 4. The occurrence of and size of any orifices opening the fill pipe head to atmosphere.

Any changes to portions of the fill pipe not in the areas defined above do not constitute a changed fill pipe head design.

III. General Design Specifications

The fill pipe and opening of the vehicle fuel tank shall conform to all specifications in the ISO standard "Road vehicles – Filler pipes and openings of motor vehicle fuel tanks – Vapour recovery system" (ISO-13331-1995(E)), as adopted June 1, 1995 and incorporated by reference herein, along with the modifications and additions below. For filler pipes with threaded-type caps, manufacturers may elect to use the alternate filler pipe sealing surface shape specified in the Society for Automotive Engineers (SAE) standard "Fuel Tank Filler Cap and Cap Retainer Threaded" (J1114), as amended August 4, 2005 and incorporated by reference herein. The alternate shape allowance would be used in lieu of section 3.1 of ISO-13331-1995(E); all other provisions of ISO-13331-1995(E) would need to be met by a manufacturer utilizing the SAE J1114 provision. If a manufacturer is changing the fill pipe head design on model year 2024 and subsequent model year vehicles, and is electing to use SAE J1114's alternate filler pipe sealing surface shape, the Alternate Shape 2 in Figure A below applies, along with the modifications in subsection (A) below, in lieu of the Alternate Shape of SAE J1114 as amended August 4, 2005. For the purpose of this section III, the manufacturer's vehicle fleet consists of the vehicles produced and delivered for sale by the manufacturer in California that are subject to this specification.

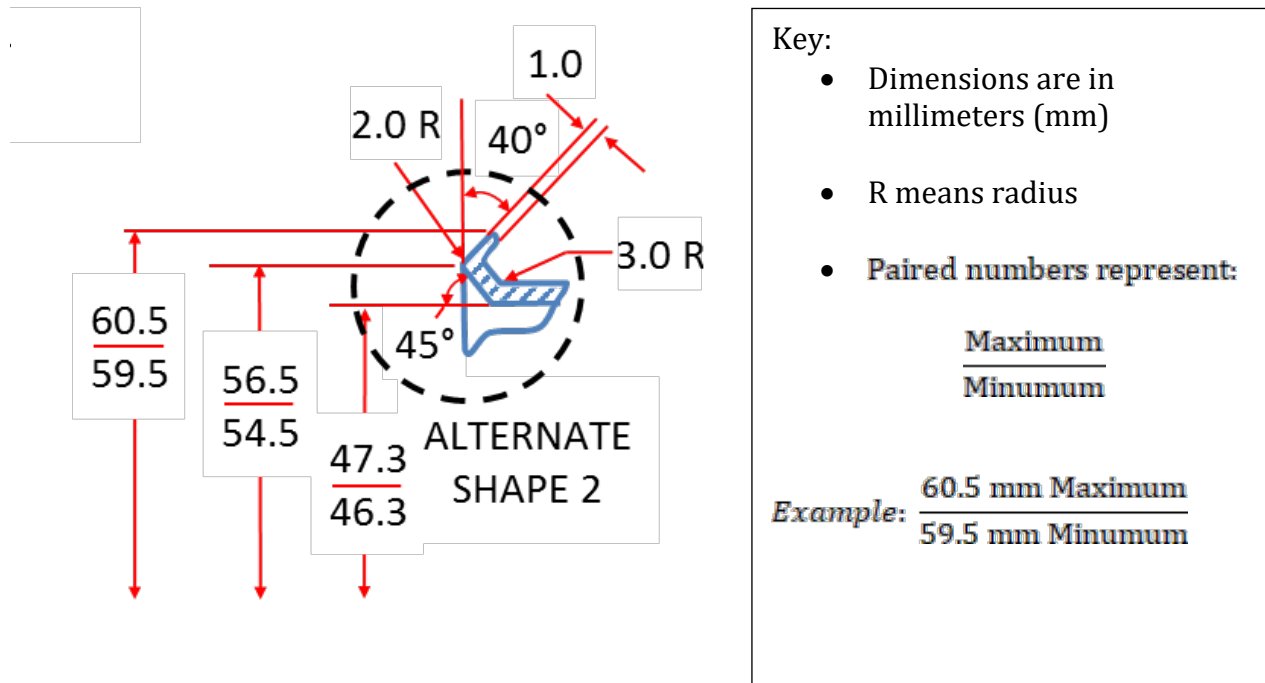
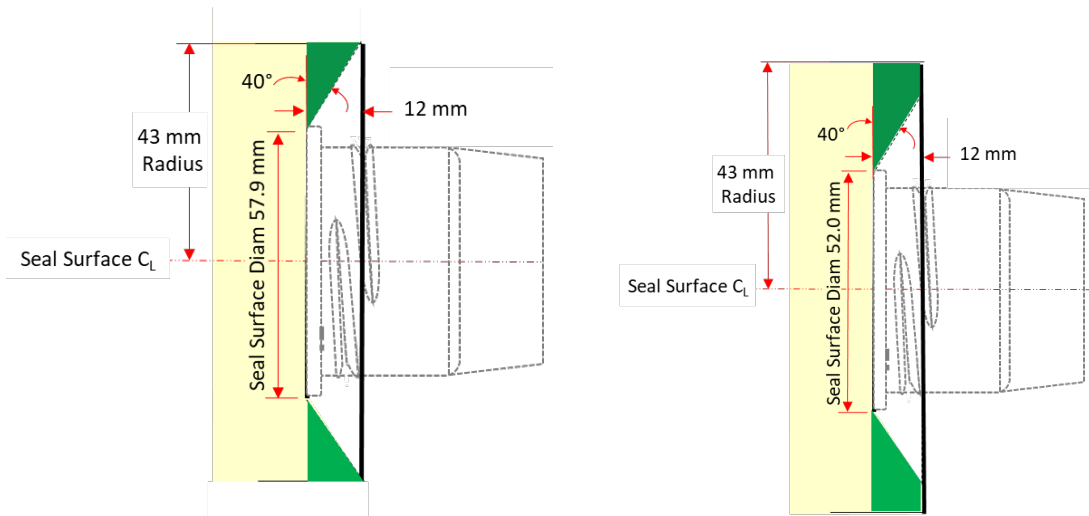

Figure A: Alternate Shape 2, cross-section of a vehicle fill pipe head.

- A. Fill pipe sealing surface, modifying or adding to ISO 13331-1995(E) Section 3.1 as adopted June 1, 1995:
- a. "Fill pipe sealing surface" means portion of the fill pipe face which would contact the vapor recovery nozzle boot face.
 - b. Diameter of the sealing surface of the fill pipe shall have a maximum diameter of 57.9 mm.
 - c. Fill pipe surfaces outside of the 57.9 mm diameter of the sealing surface are allowable so long as it does not infringe into the 40 degree tapered access zone, which extends to a depth of 12 mm back from the sealing surface of the fill pipe as described in Figure B.
 - d. These added provisions apply only when a manufacturer is changing the design of their vehicle's fill pipe head for model year 2024 and subsequent vehicle fleets.



Green shaded area: additional access zone

Yellow shaded area: for reference only, represents shape of nozzle boot

Figure B: Additional access zone, showing how the zone shape changes when applied to fill pipes with different sealing surface diameters.

- B. Modify internal locking lip depth, of ISO 13331-1995(E) Section 3.2 as adopted June 1, 1995:
- The depth of the lip shall not be less than 4 mm nor more than 11 mm into the filler pipe as measured in the reference plane, from the filler pipe sealing surface.
 - The depth of the locking lip shall be measured down to its deepest edge (edge facing the fuel tank).
 - This allowable depth range of the locking lip shall be maintained throughout at least 100 degrees of the inside circumference of the filler pipe, and extending to at least 35 degrees to either side of the reference plane.
 - This modification applies only when a manufacturer is changing the design of their vehicle's fill pipe head for model year 2024 and subsequent vehicle fleets.
- C. Modification to access zone, modifying ISO-13331-1995(E) Section 3.3:
- The fill pipe and any other vehicle parts shall not occupy space defined by the additional access zone shown in Figure B in green. The additional access zone is centered on the axis of the fill pipe sealing surface's outer diameter, and applies around the entire perimeter of the fill pipe. The additional access zone shall line up flush with the seal surface as shown in Figure B. The yellow shaded area represents the shape of a nozzle boot and is shown for reference only.
 - This modification replaces the 2.5 mm dimension of the portion of the access zone described in Figure 5, view X of ISO-13331-1995(E).
 - This modification applies only when a manufacturer is changing the design of their vehicle's fill pipe head for model year 2024 and subsequent vehicle fleets.

IV. Fill Rate Specifications

A. The fill pipe on 2015 and subsequent model year vehicles shall accept a fill rate of 10 gallons per minute using the test procedure described in Section VII.

B. There shall be no premature nozzle shut-off in 90 percent of the test repetitions for any test nozzle using the test procedures described in Section VII.

V. Spillage and Spitback Specifications

A. There shall be no more than 1 milliliter of liquid gasoline loss per test in 90 percent of the tests using the test procedures described in Section VII.

B. The nozzle shall remain in the normal resting position during dispensing and after nozzle shut-off using the test procedure described in Section VII.

VI. Bench Leak Rate Specification

A. Nozzle to Fill Pipe Interface Bench Leak Rate:

- a. Bench Leak Rate: At 500 +/- 25 Pascal vacuum, the maximum allowable leak rate is 2.5 standard liters per minute (SLPM), using the procedure described in Section VIII.
- b. The bench leak rate shall be implemented based on the phase-in schedule in Section XII.
- c. A separate test shall be performed on each individual fill pipe head configuration.
- d. Manufacturers shall either provide an attestation that vehicle fill pipe meets the Bench Leak Rate when certifying or provide actual test data.

VII. Test Procedures: Fill Rate, Spillage, and Spitback

The following test procedures and test conditions shall be used for determining compliance with the Fill Rate, Spillage, and Spitback specifications in Sections IV and V.

A. Each different fill pipe/tank configuration, as appropriate to represent adequately the manufacturer's product line, shall be tested with two vapor recovery nozzles. Each nozzle must be from a different manufacturer. At least one of the two nozzles shall be a balance-type. Each nozzle shall include a hold-open clip for hands-off dispensing. Upon the request of a vehicle manufacturer, the Executive Officer or his designate may approve alternate vapor recovery nozzles and hoses for use with the test procedures.

B. The fill pipe shall be tested as installed in the vehicle. Fuel system mock-ups sufficiently complete to demonstrate production vehicle compliance with these specifications may be used.

C. The vehicle shall be parked in a level attitude and oriented such that normal vapor and liquid hose loads are applied to the nozzle. Normal vapor and liquid hose loads may be represented by applying a retractor cable tension of approximately ten pounds to a hose clamp attached to the liquid hose approximately three feet from the nozzle as measured along the hose.

D. Gasoline used as fuel during the tests shall have a Reid vapor pressure of at least 8.5 pounds per square inch (psi) and be at a temperature of 21° plus or minus 5° Centigrade.

E. The pressure drop from the nozzle/fill pipe interface through the vapor passage shall be nominally 0.5 inch of water (gauge) as measured with a nitrogen gas flow of 60 cubic feet per hour through the vapor passage.

F. Each test shall be conducted as follows:

At the start of the test the fuel tank shall be approximately 10 percent of the nominal tank capacity. The nozzle to be used for dispensing gasoline shall be in the normal hands-off-latched position. The fill rate shall be the minimum rate necessary to demonstrate compliance with the applicable fill rate specification set forth in Section IV. The nozzle shall be allowed to dispense gasoline until automatic nozzle shut-off.

If a premature nozzle shut-off occurs, the nozzle shall be left in the fill pipe in the same position. Dispensing shall be resumed within 10 seconds at the fill rate specified in Section IV and dispensing shall continue until the fuel tank is filled to within 90 percent of the nominal fuel tank capacity or to within two gallons of the nominal fuel tank capacity, whichever corresponds to the smaller quantity of gasoline in the vehicle fuel tank.

G. A minimum of five tests with each chosen nozzle shall be completed to demonstrate compliance with the fill rate and spillage/spitback specifications. If there is any premature nozzle shut-off or instance of liquid gasoline loss greater than 1 milliliter during the first five tests with any chosen nozzle, a minimum of ten tests with that nozzle shall be completed to demonstrate compliance with the fill rate and spillage/ spitback specifications.

H. At the request of a manufacturer, the Executive Officer may approve the use of an alternative test procedure by the manufacturer upon a determination that the alternative test procedure is equivalent to the adopted test procedure. The manufacturer shall be responsible for demonstrating the equivalency of the alternative test procedure.

I. For fill pipe/tank configurations with fuel system designs unchanged from a prior model year, and which have been tested using the adopted test procedure or by

an equivalent test procedure acceptable to the Executive Officer as specified in Section VII.H, the test results from the prior model year may be used for determining compliance to these specifications.

VIII. Test Procedure: Bench Leak Rate

- A. Secure the test fill pipe into the fill pipe mounting fixture.
 - a. Fill pipe should be oriented such that:
 - i. Fill pipe opening, at center, is at a height of 37 +/- 2 inches above the ground.
 - ii. Pipe axis angle with respect to horizontal shall be 32 +/- 2 degrees.
 - iii. Internal locking lip degrees on each side of the vertical reference plane meet the vehicle manufacturer's specification, within +/- 5 degrees.
- B. Interconnect the fill pipe, flow meter, pressure gage, and vacuum source, as shown in Figure C.
 - a. Vacuum and pressure/flow measurement hose shall be routed inside the assist vapor recovery nozzle's (assist nozzle¹) boot.

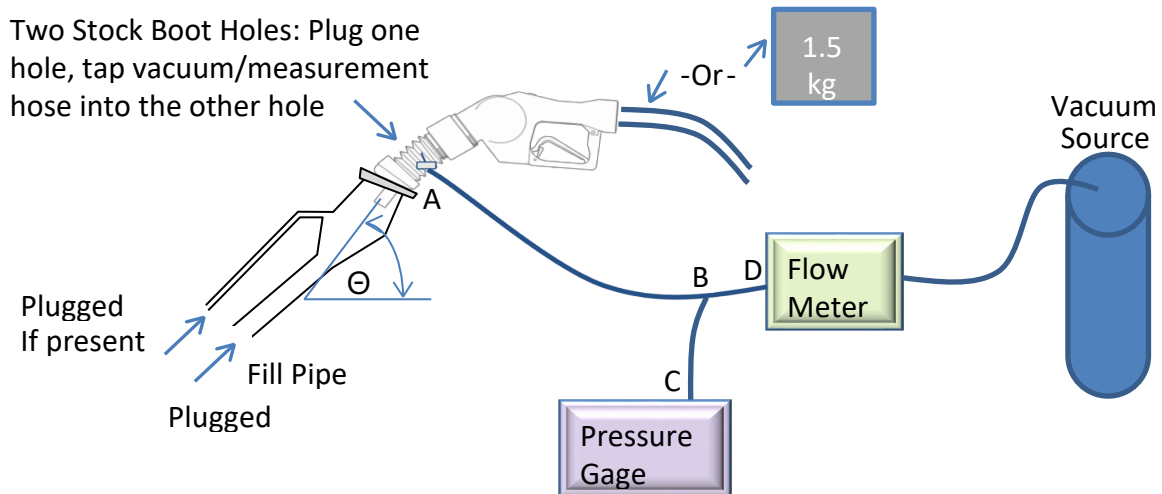

Figure C: Set-up of Testing Equipment

- C. The outlet of the fill pipe shall be plugged.
- D. If the fill pipe has a recirculation line, the recirculation line shall be plugged.
- E. One of the two pre-existing holes in the boot of the assist nozzle shall be used for routing the hose that connects the vacuum source, pressure gage, and flow meter into the nozzle, and the other hole shall be plugged.
- F. The hose dimensions shall be as indicated in Table 1.

Table 1: Hose dimensions for bench leak test

Location (between points in Figure C)	Hose Length (inches)	Hose Inner Diameter (inches)
A-B	128 +/-2	3/16 to 1/4
B-C	40 +/-2	3/16 to 1/4
B-D	16 +/-2	3/16 to 1/4

- G. Latch an assist nozzle into the fill pipe using a natural motion as you would when filling up your own car at a gas station.
- H. Hose should form a “U” shape, and be within 6-12 inches from the ground at its lowest point. As an alternative to the hose, attach a 1.5 kg weight to the nozzle, at the end where a hose would normally connect to.
- I. Adjust the vacuum source until a vacuum level is stabilized to vary no more than 500 +/- 50 Pascal over a two minute period during which no adjustments are made.
 - a. Record the flow rate at a vacuum of 500 +/- 25 Pascal.
- J. The above procedure shall be repeated with five more iterations with the same fill pipe head design.
- K. The average of the six flow rate measurements shall meet the specification as indicated in Section VI.

¹ For specifications for assist vapor recovery nozzles, see CARB Executive Order VR-202-X, Relating to Certification of Vapor Recovery Systems Assist Phase II Enhanced Vapor Recovery (EVR) System Including In-Station Diagnostics (ISD), Exhibit 1, p. 1. February 15, 2019, incorporated by reference herein.

IX. Specifications to Reduce Damage to Vapor Recovery Nozzles

To avoid damage to the bellows and faceplates of vapor recovery nozzles, there shall be no sharp projections or edges within the fill pipe access zone, along the surface of the fill pipe access zone, or along the surface of adjacent zones outside of the fill pipe access zone, which could foreseeably damage the bellows or faceplate of nozzles during nozzle insertion, latching, dispensing or removal. Fill pipe access doors, including license plate holders and license plates when used as access doors, and all associated door and license plate mounting brackets, screws, and other hardware shall stand free of the fill pipe access zone during nozzle insertion, latching, dispensing, and removal. This Section shall also apply to all factory installed accessories in the vicinity of the fill pipe and opening.

X. Fill Pipe Assembly and Restriction Device Durability and Other Specifications

A. The manufacturer of each motor vehicle shall warrant to the ultimate purchaser and each subsequent purchaser that he vehicle is: (1) designed, built, and

equipped so as to conform, at the time of sale, with the specifications in Sections IV, V, IX, X.B, and X.C herein, and (2) free from defects in materials and workmanship which cause the fill pipe assembly, including restriction device, to fail to conform to the specifications in Sections IV, V, IX, X.B, and X.C herein for the useful life of the vehicle as defined in Section 2035 of Title 13, California Code of Regulations. The provision of Sections 2037 (d) – (k), 2038, 2039, 2040, and 2041 of Title 13, California Code of Regulations, shall be applicable to the warranty. The fill pipe assembly, including restriction device, shall be subject to vehicle emissions related defects report and vehicle or engine recall procedures in Title 13, Chapter 3, Subchapter 2, Article 2, California Code of Regulations.

B. Any restriction device in a motor vehicle shall be sufficiently durable to withstand simple tampering and to prevent expansion of the restriction device diameter to 2.4 centimeters or removal of the restriction device without extraordinary effort.

C. The fill pipe assembly including fuel tank cap shall not expel liquid gasoline during normal driving maneuvers or parking attitudes for which the vehicle is designed irrespective of ambient temperature or tank level up to nominal capacity.

D. The fill pipe assembly of all methanol-fueled vehicles shall be designed to resist the insertion of flexible tubing of a diameter that is feasible for use in siphoning fuel. Manufacturers of methanol-fueled heavy-duty vehicles in excess of 14,000 pounds gross vehicle weight may request an exemption from this requirement. The request shall be submitted to the Executive Officer and shall be granted if the manufacturer demonstrates that compliance with this requirement is technically infeasible.

XI. Exemption of Vehicles

A. A manufacturer may apply for an exemption from the fill pipe and fuel tank opening specifications in Sections III through X for any of its vehicles by applying in writing to the Executive Officer. Application should be submitted at least 60 days prior to the manufacturer's date for final design commitment. The application shall set forth:

1. the specific models for which the exemption is sought;
2. for each such model all facts which demonstrate that compliance with the specifications is technologically infeasible; and
3. evidence showing what efforts have been and will be made by the manufacturer to overcome technological infeasibility, and what the state-of-art technology and problems consist of.

B. Upon receipt of an exemption application, together with sufficient supporting evidence, the Executive Officer may make a finding of technological infeasibility and grant an exemption. The exemption may be limited to specific models, specified body styles of any vehicle model, and/or specified model years. In

determining whether to grant an exemption, the Executive Officer shall consider technologies available to the motor vehicle industry as a whole. The Executive Officer may condition an exemption upon a commitment by the manufacturer to develop new technologies in accordance with a responsible compliance schedule approved by the Executive Officer. No exemption shall be granted unless the manufacturer has demonstrated a good faith effort to overcome technological infeasibility.

C. The manufacturer shall bear the responsibility for submitting evidence to the Executive Officer sufficient to justify the granting of an exemption.

XII. Phase-in schedule

A. This phase-in schedule only applies to the Bench Leak Rate Specification as indicated in Section VI. Otherwise, all requirements in this document are considered effective for the 2015 and subsequent model years or as otherwise indicated.

B. For each model year, a manufacturer shall certify, at a minimum, the specified percentage of its vehicle fleet to these standards according to the implementation schedule set forth below. For the purpose of this section XII, the manufacturer's vehicle fleet consists of the manufacturer's projected California sales volume of vehicles that are subject to this specification.

<u>Model Years</u>	<u>Minimum Percentage of Vehicle Fleet⁽¹⁾</u>
<u>2022</u>	<u>25</u>
<u>2023</u>	<u>50</u>
<u>2024 and subsequent</u>	<u>100</u>

⁽¹⁾ Small volume manufacturers are not required to comply with the phase-in schedule set forth in this table. Instead, they shall certify 100 percent of their 2024 and subsequent model year vehicle fleet to the specific requirements for which this document indicates to use a phase-in schedule.