

California Regulation for the
Mandatory Reporting of Greenhouse Gas Emissions

GHG Reporting Kickoff for 2013

Regulation Changes, Cal e-GGRT, Guidance,
Missing Data Substitution, Unit Aggregation

February 14, 2013

Presentation Slides Available Here:

<http://www.arb.ca.gov/cc/reporting/ghg-rep/ghg-rep.htm>

Outline

- Overview of 2011 Data Reported in 2012
- Preparing for 2012 Reporting
- Cal e-GGRT Reporting Tool
- Regulation Updates
- Guidance Documents
 - Missing Data Provisions
 - Unit Aggregation
- Resources
- Q&A following each main section

2011 Data Reporting Recap

- 581 reports submitted
 - 434 facilities, 55 suppliers, 92 electric power entities
- 491 subject to verification
 - 97% received positive emissions verification statements
 - 11 reports received adverse statements
- Summary data posted for all reports
 - http://www.arb.ca.gov/cc/reporting/ghg-rep/reported_data/ghg-reports.htm

Enforcement Summary

- ARB is currently undertaking enforcement action concerning several entities
- Issues that could lead to enforcement actions
 - Incorrect data submitted
 - Errors leading to a material misstatement
 - Failure to fix correctable errors
 - Late reports or failure to report
 - Late verification or no verification
- As completed, any case settlements will be posted here:
<http://www.arb.ca.gov/enf/casesett/casesett.htm>

Reporting Schedule

- **NO time EXTENSIONS** will be granted
- April 10, 2013
 - Reports due for everyone except those listed for June 3
- June 3, 2013
 - Reports due for electricity retail providers and marketers
 - Reports due for abbreviated reporters (<25k)
- Failure to submit a report by the required deadline is a violation of the regulation for each day the report remains unsubmitted
- Key Dates Reference Page:
<http://www.arb.ca.gov/cc/reporting/ghg-rep/ghg-rep-dates.htm>

Verification Schedule

- **NO time EXTENSIONS** will be granted
- September 3, 2013
 - Final Verification Statements due for all emissions and product data
- Start early to ensure on-time completion
- Provide adequate time to correct any issues identified during verification
- Verifiers must submit **ADVERSE** statement if verification not completed on time
- Failure to have a verification statement(s) submitted by the verification deadline is a violation of the regulation for each day the verification statement remains unsubmitted

Reporting Tips

- Start early, finish early
- Involve verifier as soon as possible
- Plan enough time to make verification revisions
- Update DR, ADR, Agents if needed
 - They have access to system until you remove them
- Contact ARB for any questions about requirements (ghgreport@arb.ca.gov)
 - Save and file any ARB responses as part of your GHG Monitoring Plan
- Check ARB guidance:
<http://www.arb.ca.gov/cc/reporting/ghg-rep/guidance/guidance.htm>

Reporting Tips

- Make sure to add natural gas and electricity purchases in Subpart A (required data)
 - New selection pull-downs added
- Fuel use must be entered even if using CEMS
- Review new unit aggregation requirements on guidance page
- Make sure you have a complete GHG Monitoring plan to avoid non-conformance
 - Must include all elements in §95105(c)(1-10)

Verification Tips

- Correctable Errors must be fixed
 - If not, verifier must provide **adverse** verification
- “Covered Emissions” and “Covered Product Data” must meet accuracy requirements
- If verifier and reporter disagree on requirements, always contact ARB for assistance
- Maintain all ARB clarifications in GHG Monitoring Plan

Cal e-GGRT Tool Availability



- February 13, 2013
 - 2012 data reporting activated
- Existing 2011 data configurations have been migrated to 2012 reports
 - Reduces setup workload
- Electric Power Entity module will be activated in late March

Cal e-GGRT for New Reporters



- If newly subject to GHG reporting, email name of company or entity, and Designated Representative email address to: ghgreport@arb.ca.gov
- ARB will create an account in the system and provide instructions for registration
- Archived training materials are available here: <http://www.arb.ca.gov/cc/reporting/ghg-rep/tool/ghg-tool.htm>
 - Registration, stationary combustion, sectors

AB 32 SF₆ Data Reporting



- SF₆ data must now be reported in separate Cal e-GGRT facility/entity account
 - Cannot be combined with main facility or entity
- If affected, a new account will be created and the Designated Representative will be notified
- System will not allow SF₆ module to be selected if other modules/subparts are selected
- Necessary to enforce strict data locking following mandatory reporting verification

AB 32 Fees Data Reporting



- Transportation Fuel Suppliers
 - Must report data to both Subpart MM and Fees Modules
 - Different data requirements for Fees and MM
- Do not report natural gas received in Fees module – This is for suppliers only
- Fees Billing Address is now entered on main Facility Management tab, not Fees module

Updates to the Regulation for 2012 Data Reporting

Regulation Updates

- Revisions went into effect January 1, 2013
- Regulation available here:
http://www.arb.ca.gov/cc/reporting/ghg-rep/regulation/mrr_regulation.htm
- Most updates relatively minor
- Majority of updates clarify preexisting requirements, and are applicable to 2012 data reporting in 2013
 - Accuracy requirements clarified for “covered” product and emissions data
 - Unit aggregation requirements
 - Meter calibration and accuracy requirements
 - Best available monitoring methods for the oil & gas sector
 - Verification applicability for “no-threshold” reporters

Regulation Updates

- A few updates are applicable for 2013 data reported in 2014
 - Oil and Gas Sector (§95153(c, g, v, y))
 - Reporting of process emissions for abbreviated reporters.
- See spreadsheet for listing of all regulation changes: <http://www.arb.ca.gov/cc/reporting/ghg-rep/guidance/guidance.htm>

Missing Data Provisions

Introduction

- Apply to 2012 data reported in 2013 and all future years
- Stationary fuel combustion and CEMS → Section 95129
- Process and fugitive emissions → see each industry-specific rule section
- New guidance published at:
<http://www.arb.ca.gov/cc/reporting/ghg-rep/guidance/guidance.htm>

Applicability

- Missing Data Period = a time period when a piece of data is:
 - Not collected
 - Invalid
 - Collected while the measurement device is not in compliance with the applicable quality-assurance requirements
- Not all missing data situations require the use of the procedures in §95129. Check before you apply the procedure.

Sources Not Subject to §95129

- Sources that are not required to meet the calibration and accuracy standards of §95103(k) may use best available estimate and are not subject to §95129:
 - Any emission sources in a facility that qualifies for abbreviated reporting
 - Emission units that combust only exempt biomass-derived fuels
 - De minimis sources

Missing Data: Fuel Characteristic Data

- For purposes of missing data, the data capture rate calculation excludes time periods when no fuels were combusted
- §95129(c) is triggered only after all the following alternatives have been exhausted:
 - (data acquired from these alternatives are not considered “missing”)
 - Reanalyze the original sample if it is still available
 - Analyze a backup sample from the same sampling period
 - If the sampling period has not passed, analyze a replacement sample
 - Get data from the fuel supplier

Missing Data: Fuel Consumption Data

- Data capture rate calculation excludes time periods when no fuels were combusted
- §95129(d) is triggered only when the *total* facility fuel consumption is not completely and accurately known
- Can use any combinations of upstream/downstream meters to demonstrate that the total facility fuel consumption is completely and accurately known for any time period
- However, all devices for such demonstration must *individually* meet the accuracy standard

Fuel Consumption Data (Situation 1)

Situation 1: *Total facility fuel consumption is completely and accurately known, but unit-level fuel use is missing*

- §95129(d)(1)-(3) is not triggered
- Options:
 - Use any combination of up/downstream meters to reconstruct the missing unit-level data
 - Triangulate the missing unit-level data using other fuel meters along the main fuel line or branches of the fuel line
 - If there is an accurate meter upstream, engineering estimate is acceptable for downstream units
 - Follow §95129(d)(1)-(3)

Fuel Consumption Data (Situation 1 Examples)

Example 1: Use any combination of up/downstream meters to reconstruct the missing unit-level data.

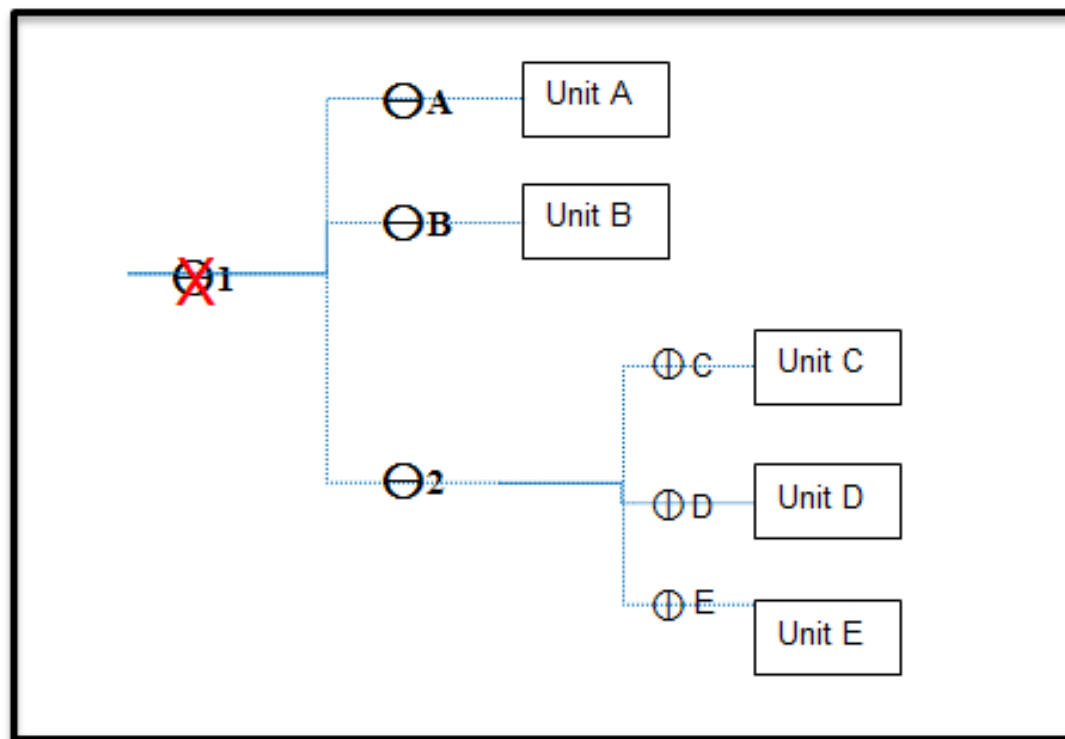

⊖ Accurate fuel meter

⊕ Fuel meter without accuracy demonstration

X Failed meter

— Fuel line

Fuel Consumption Data (Situation 1 Examples)

Example 2: Triangulate the missing unit-level data using other fuel meters along the main fuel line or branches of the fuel line

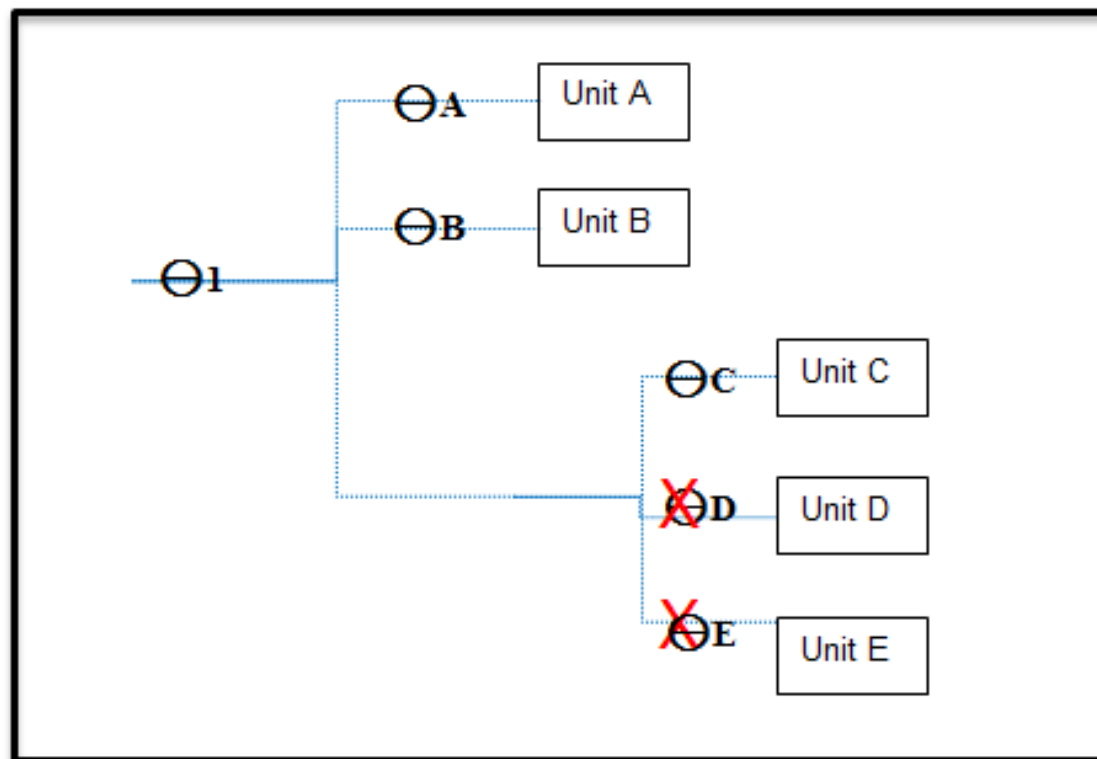

- ⊖ Accurate fuel meter
- ⊙ Fuel meter without accuracy demonstration
- X Failed meter
- Fuel line

Fuel Consumption Data (Situation 1 Examples)

Example 3: If there is an accurate meter upstream, engineering estimate is acceptable for downstream units

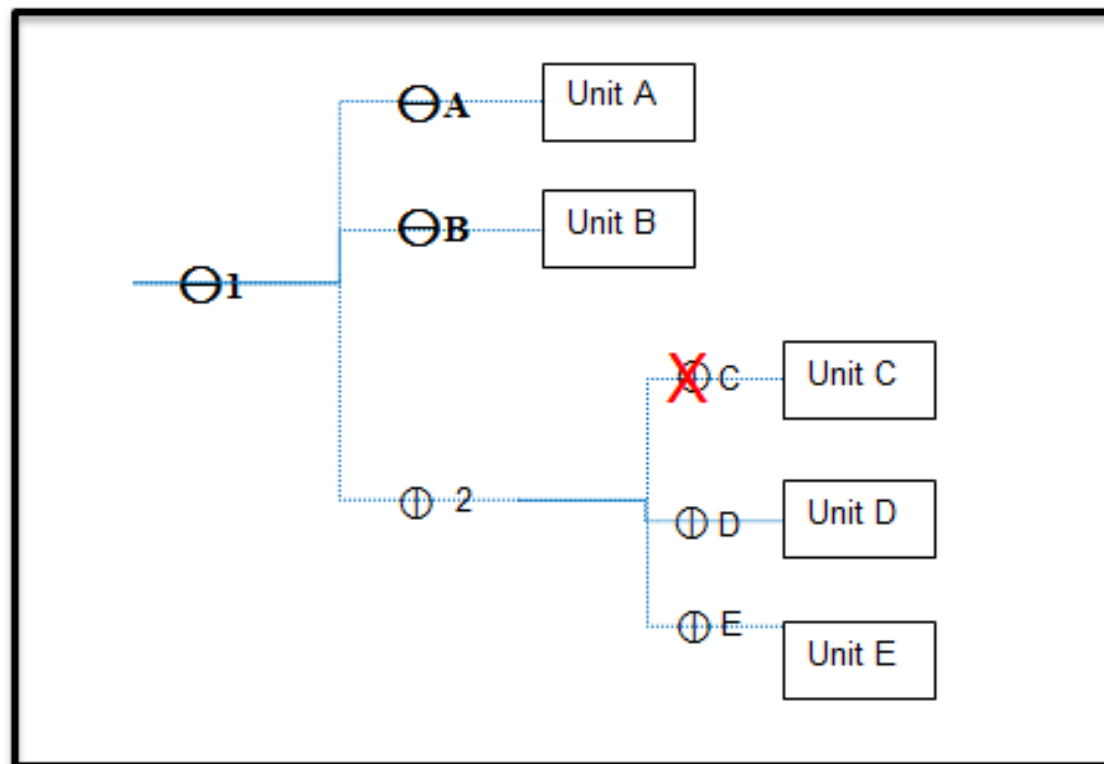

- ⊖ Accurate fuel meter
- ⊕ Fuel meter without accuracy demonstration
- X Failed meter
- Fuel line

Fuel Consumption Data (Situation 2)

Situation 2: *Total facility fuel consumption is NOT completely and accurately known, and it cannot be reconstructed from any combinations of other accurate meters*

- §95129(d)(1)-(3) is triggered
- Take immediate corrective action to end the missing data period
- Options:
 - Install accurate temporary meters
 - Calibrate any combinations of existing upstream/downstream meters

Fuel Consumption Data (Situation 2)

- However, §95129(d)(1)-(3) still applies during the time period *after* the failure of the original meter *and before*
 - the complete installation of temporary meters, OR
 - calibration of existing up/downstream meters
- GHG Monitoring Plan
- Keep all calibration records
- Must be able to demonstrate meter accuracy to the verifier. Otherwise, §95129(d)(1)-(3) is required.

Fuel Consumption Data (Situation 2 Examples)

Example 1

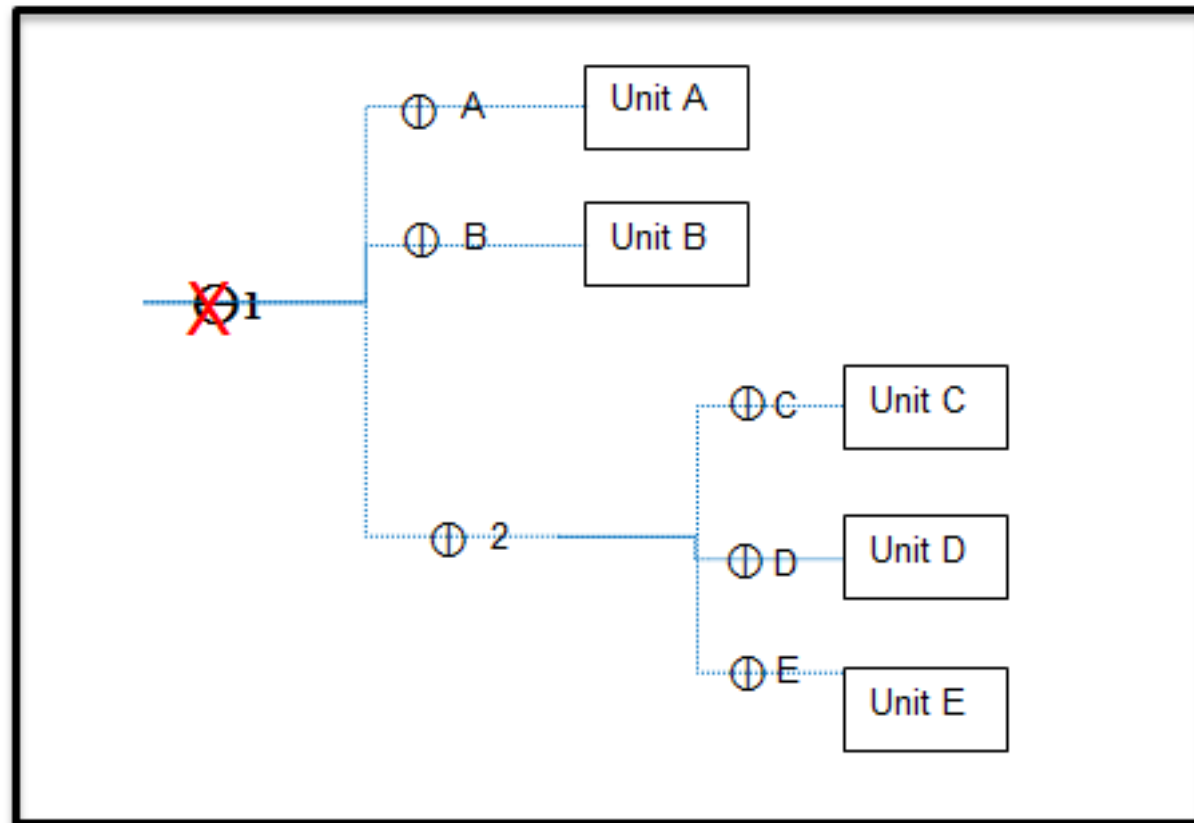

- ⊖ Accurate fuel meter
- ⊕ Fuel meter without accuracy demonstration
- X Failed meter
- Fuel line

Fuel Consumption Data (Situation 2 Examples)

Example 2

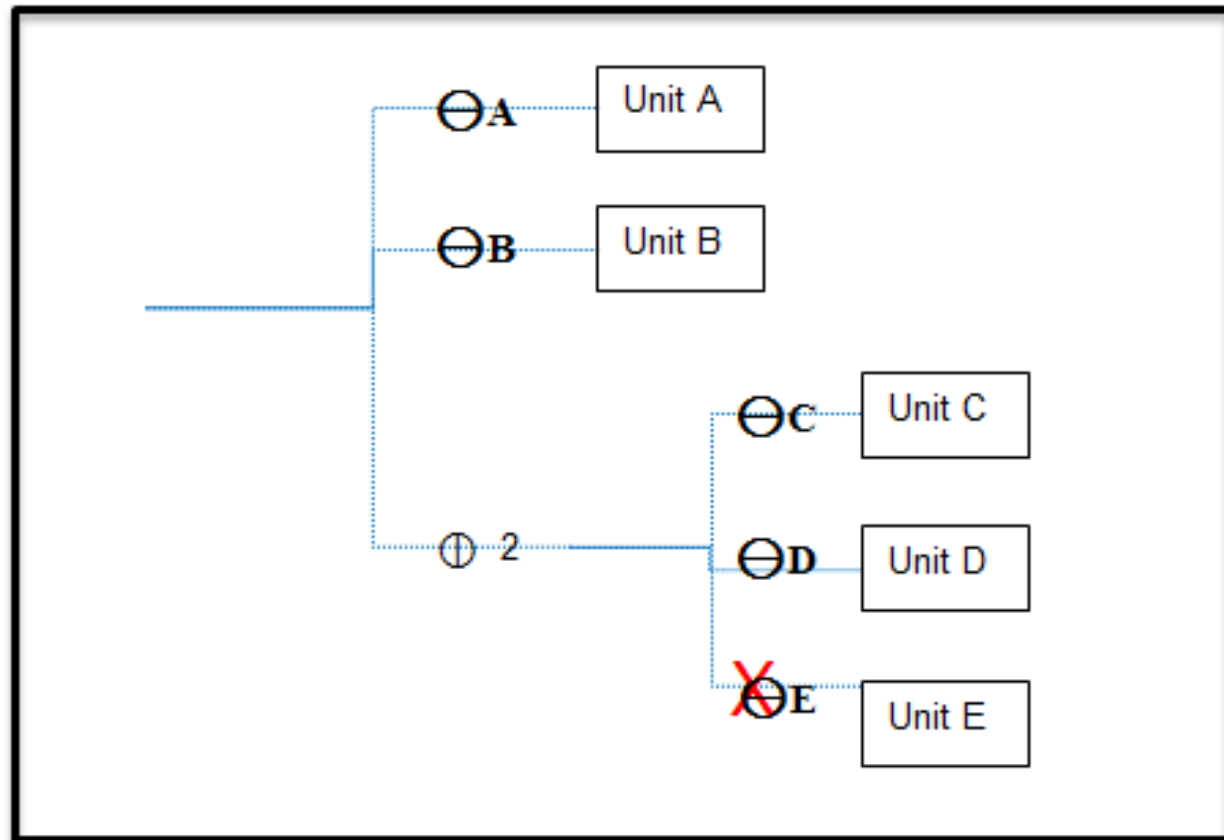

\ominus Accurate fuel meter

\oplus Fuel meter without accuracy demonstration

\otimes Failed meter

— Fuel line

Nonconformance Determination

- §95131(b)(13)(D): A nonconformance is automatically triggered if:
 - Data capture rate is <80% for any single data element, regardless of the amount of emissions that are affected, or
 - >5% of total facility emissions have been replaced due to missing data
- Data that are correctly substituted according to the regulation are accepted as accurate and not misreported in material misstatement evaluation
- See example in guidance

Unit Aggregation

Introduction

- Unit Aggregation Provisions: §95115(h) and §95112(b)
[aggregation of electricity generating units (EGU) will be discussed in more detail during the EGU webinar]
- Review the guidance in detail before making unnecessary changes to fuel metering practices and reporting tool configurations

Aggregation of Stationary Fuel Combustion (SFC) Units

- Aggregation by unit type:
 - Boiler
 - Reciprocating internal combustion engine (RICE)
 - Turbine
 - Process heater
 - Other (none of the above)
- Cannot aggregate if associated with different industries/ source categories [§95101(a)(1)(A)-(B) and 40 CFR Part 98 Tables A-3, A-4, A-5]
- Electricity generating units/systems (EGU/EGS) must always be separately reported from other SFCs

Engineering Estimation

If a facility has meters such that the total facility fuel use is completely and accurately known, but lacks lower-level meters to meet the unit aggregation limitations of the revised regulation:

- Engineering estimation is acceptable *as long as* the estimated lower-level fuel use values add up to the accurate total upstream emissions *and* the operator can demonstrate to the verifier that the chosen estimation method is reasonable

Entering Information In the Reporting Tool

- In most cases, reporters may maintain the existing unit configurations in the reporting tool
- If the existing unit configuration does not meet the revised rule requirements for unit aggregation, reporters must fill out a new table with disaggregated information by unit type

PERCENT OF FUEL GROUPED INTO THIS CONFIGURATION ATTRIBUTED TO EACH UNIT TYPE (If more than one unit type is aggregated into the group, the reporter is required to provide the following information (§95115(h)))

Fuel (pull-down menu)	Type of Unit (pull-down menu)	Percent of Fuel*
Natural gas	Boiler	60 %
Natural gas	Heater	40 %

*The percent of fuel must add up to 100% for each fuel type.

- Alternatively, reporters may create new unit configurations as long as they meet the revised requirements

Common Stack

- If an operator reports CO₂ emissions using “common stack” configuration per 40 CFR §98.36(c)(2)
- Complete the information in the tool the same way as before, but provide additional information in a new table

PERCENT OF FUEL GROUPED INTO THIS CONFIGURATION ATTRIBUTED TO EACH UNIT TYPE (If more than one unit type is aggregated into the group, the reporter is required to provide the following information (§95115(h))

Fuel (pull-down menu)	Type of Unit (pull-down menu)	Percent of Fuel*
Natural gas	Boiler	60 %
Natural gas	Heater	40 %

*The percent of fuel must add up to 100% for each fuel type.

Guidance Available

- New guidance is available for unit aggregation:

<http://www.arb.ca.gov/cc/reporting/ghg-rep/guidance/guidance-docs.htm>

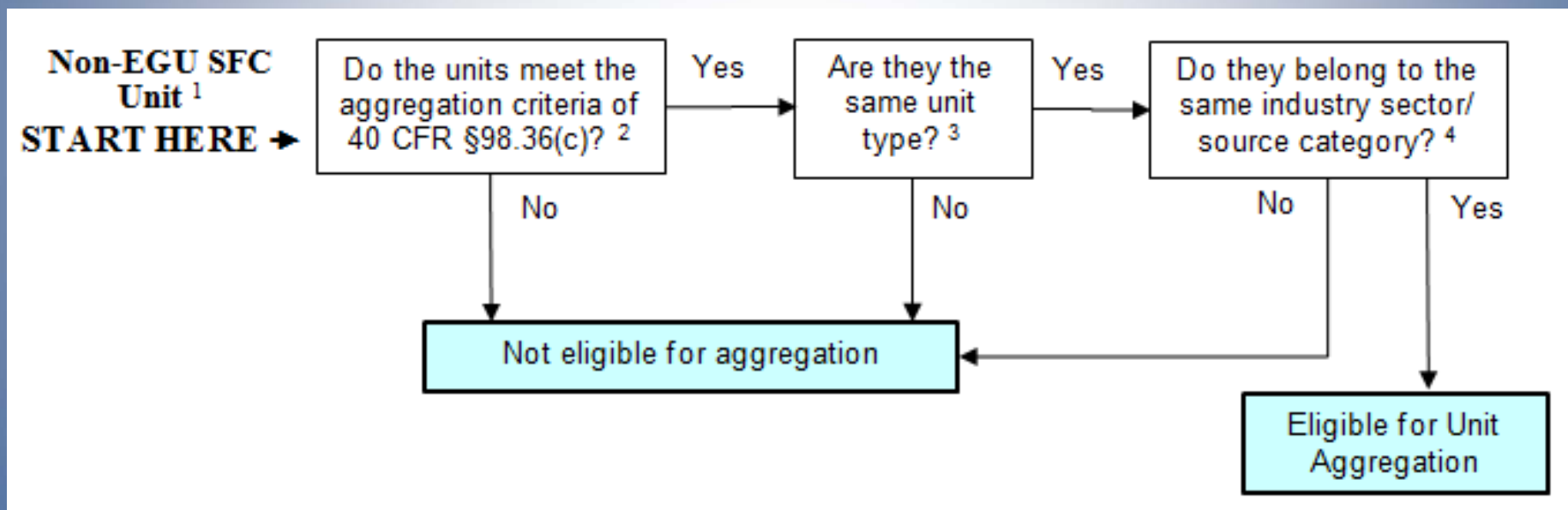

Resources

Additional Training Sessions

- ARB sector-specific training (check link for times)
<http://www.arb.ca.gov/cc/reporting/ghg-rep/guidance/guidance.htm>
 - February 14th - Electricity Generation and Cogeneration
 - February 20th - Petroleum and Natural Gas Systems
 - February 21th - Fuel Suppliers – Transportation, NG, etc.
 - February 28th - Refinery Product Data
 - March 26th - Electric Power Entities (tentative)
- Contact ARB staff as needed for questions

Verification Guidance Materials

- Includes check-lists and other resources used by verifiers during verification
- Identifies key data needed for successful verification and compliance with the regulation
- To be posted here (in March):
<http://www.arb.ca.gov/cc/reporting/ghg-ver/ghg-ver.htm>

Helpful Web Sites

- Email reporting questions to: ghgreport@arb.ca.gov
- Reporting Guidance: Applicability, Metering
<http://www.arb.ca.gov/cc/reporting/ghg-rep/guidance/guidance.htm>
- Cal e-GGRT Tool Training: Registration, Subparts
<http://www.arb.ca.gov/cc/reporting/ghg-rep/tool/ghg-tool.htm>
- Cal e-GGRT Main Help Page
<http://www.ccdsupport.com/confluence/display/calhelp/Home>

Key Reporting Dates

Date	Activity
February 1	Regulatory deadline: Due date for electric power entities to register specified facilities outside California
February 13	Public release of Cal e-GGRT
April 10	Regulatory deadline: Reporting deadline for facilities and suppliers of fuels and carbon dioxide, except when subject to abbreviated reporting
June 3	Regulatory deadline: Reporting deadline for electric power entities and those subject to abbreviated reporting
July 15	Regulatory deadline: Deadline for corrections to RPS Adjustment data required for electric power entity data reports
September 3	Regulatory deadline: Final verification statements due (emissions data and product data)

GHG Reporting Contacts

Subject Matter	Contact
GHG Mandatory Reporting (General)	Dave Edwards , Manager 916.323.4887
Reporting Requirements, Stationary Combustion, Other Sectors (cement, glass, pulp and paper, etc.)	Patrick Gaffney 916.322.7303
Reporting Tool Registration and General Questions	Karen Lutter 916.322.8620
Electricity Generation and Cogeneration Facilities	Anny Huang 916.323.8475
Electricity Retail Providers and Electricity Marketers	Wade McCartney 916.327.0822
Fuel and CO ₂ Suppliers - Transportation Fuels, Natural Gas, LPG, CO ₂	Syd Partridge 916.445.4292
Petroleum Refineries, Hydrogen Plants, Oil & Gas Production	Byard Mosher 916.323.1185
Product Data – Refineries, and Oil & Gas	Joelle Howe 916.322.6349
Greenhouse Gas Report Verification	Renee Lawver , Manager 916.322.7062
Chief – Greenhouse Gas Emission Inventory Branch	Richard Bode , Chief 916.323-8413

End