



**CALIFORNIA**  
AIR RESOURCES BOARD

**STANDARD OPERATING PROCEDURES  
FOR  
RM YOUNG 81000  
ULTRASONIC ANEMOMETER**

AQSB SOP 506

Third Edition

MONITORING AND LABORATORY DIVISION

February 2024

Disclaimer: Mention of any trade name or commercial product in this standard operating procedure does not constitute endorsement or recommendation of this product by the California Air Resources Board. Specific brand names and instrument descriptions listed in the standard operating procedure are for equipment used by the California Air Resources Board's laboratory. Any functionally equivalent instrumentation is acceptable.



# CALIFORNIA

## AIR RESOURCES BOARD

### Approval of Standard Operating Procedures

Title: RM Young Model 81000 Ultrasonic Anemometer

SOP: AQSB SOP 506, Third Edition

Section: Operations and Data Support

Branch: Air Quality Surveillance Branch (AQSB)

Division: Monitoring and Laboratory Division (MLD)

Prepared by: Operations and Data Support Section

Reviewed by:

*msingh*

Manisha Singh, Ph.D., Chief  
Quality Management Branch

6/13/2024

Date:

Approved by:

*Reginald Smith*

Reggie Smith, Manager  
Operations and Data Support  
Section

21 June 2024

Date:

*Kathleen Gill*

Kathleen Gill, Chief  
Air Quality Surveillance Branch

06/21/2024

Date:

## Table of Contents

<b>REVISION HISTORY .....</b>	<b>5</b>
<b>LIST OF ACRONYMS.....</b>	<b>6</b>
1.1 INTRODUCTION: .....	7
1.2 PRINCIPLE OF OPERATION: .....	7
1.3 DESCRIPTION OF RM YOUNG 81000 ULTRASONIC ANEMOMETERS:.....	7
1.4 INTERFERENCES AND SAFETY CONSIDERATIONS: .....	8
1.5 PERSONNEL QUALIFICATIONS: .....	9
<b>2.0 INSTALLATION PROCEDURE .....</b>	<b>11</b>
2.1 INSTALLATION OVERVIEW: .....	11
2.2 EQUIPMENT REQUIRED FOR INSTALLATION:.....	11
2.3 MOUNTING THE SENSOR TO AN EXISTING METEOROLOGICAL TOWER: .....	11
2.4 SENSOR ALIGNMENT TO TRUE NORTH: .....	13
2.5 CONNECTING TO DATA LOGGERS: .....	15
2.6 3D SONIC RS-232 SENSOR CABLE: .....	15
2.7 3D SONIC SENSOR CONFIGURATION:.....	19
<b>3.0 DATA ACQUISITION AND CONFIGURATION .....</b>	<b>22</b>
3.1 CARBLOGGER CONFIGURATION: .....	22
<b>4.0 SENSOR CERTIFICATION .....</b>	<b>24</b>
4.1 INTRODUCTION: .....	24
4.2 RM YOUNG 81000 CERTIFICATION AND CALIBRATION FREQUENCY:.....	24
4.3 SENSOR REPLACEMENT PROCESS: .....	26
4.4 FACTORY RETURN PROCESS:.....	27
<b>5.0 OPERATIONAL AND ROUTINE SERVICE CHECKS.....</b>	<b>29</b>
5.1 DAILY (OR EACH SITE VISIT) CHECKS: .....	29
5.2 WEEKLY CHECKS:.....	29
5.3 MONTHLY CHECKS: .....	29
5.4 SEMI-ANNUAL CHECKS: .....	29
5.5 ANNUAL CHECKS: .....	29
<b>6.0 MAINTENANCE PROCEDURES.....</b>	<b>30</b>
6.1 GENERAL INFORMATION: .....	30
<b>7.0 TROUBLESHOOTING.....</b>	<b>31</b>
7.1 GENERAL INFORMATION: .....	31
7.2 COMMON ISSUES: .....	31

**8.0 QUALITY CONTROL AND ASSURANCE..... 33**

8.1 GENERAL INFORMATION: ..... 33

8.2 QUALITY CONTROL: ..... 33

8.3 QUALITY ASSURANCE: ..... 33

**REFERENCES ..... 34**

**FIGURES**

Figure 1: RM Young 81000 3D Sonic Sensor..... 10

Figure 2: Sensor Installation View ..... 12

Figure 3: Alignment Sticker..... 13

Figure 4: Sensor Mounting Collar ..... 14

Figure 5: Checking 3D Sonic Input Voltage..... 16

Figure 6: RM Young 81000 RS232 Connections ..... 17

Figure 7: RM Young 81000 RS232 Wiring Diagram ..... 18

Figure 8: RM Young 81000 Set-up Menu ..... 20

Figure 9: CARBLogger "Query" Command ..... 23

Figure 10: CARBLogger Display..... 23

Figure 11: Certificate of Calibration and Testing ..... 25

**TABLES**

Table 1. Common Issues and Possible Solutions ..... 32

**APPENDICES**

Appendix A: Monthly Quality Maintenance Checksheet for Ultrasonic Anemometer 35

Appendix B: RM Young Calibration Frequency Memo ..... 36

## REVISION HISTORY

<b>Edition</b>	<b>Release Data</b>	<b>Changes</b>
First	April 2017	New Document
Second	July 2020	ADA Remediation Removed ESC data logger and analog connection references. Add sensor replacement process section.
Third	February 2024	Three-year review Add Section 4.4 Linked Appendices

## LIST OF ACRONYMS

3D	Three-Dimensional Space
3DST	Sonic Temperature
AMNS	Air Monitoring North Section
AMSS	Air Monitoring South Section
AQS	Air Quality System
AQSB	Air Quality Surveillance Branch
CARB	California Air Resources Board
CFR	Code of Federal Regulations
CL	CARBLogger
DAS	Data Acquisition System
DC	Direct Current
DMS	Data Management System
mA	milliamps
MET	Meteorological
MLD	Monitoring and Laboratory Division
NIST	National Institute of Standards and Technology
O.D.	Outside Diameter
ODSS	Operations and Data Support Section
PQAO	Primary Quality Assurance Organization
PST	Pacific Standard Time
QA	Quality Assurance
QAS	Quality Assurance Section
QA/QC	Quality Control/Quality Assurance
QMB	Quality Management Branch
SLAMS	State and Local Air Monitoring Stations
SOP	Standard Operating Procedure.
SOS	Speed of Sound
U.S. EPA	United States Environmental Protection Agency

## GENERAL INFORMATION

### 1.1 Introduction:

This standard operating procedure (SOP) describes procedures used by the California Air Resources Board (CARB) Air Quality Surveillance Branch (AQSB) to operate the RM Young Company 81000 Ultrasonic Anemometer for the measurement of meteorological parameters. This procedure was designed to supplement the manufacturer's instrument manual by describing any modifications in operating procedures, if any, implemented by CARB and is not intended to be a replacement for the instrument manual.

### 1.2 Principle of Operation:

The RM Young Company Model 81000 Ultrasonic Anemometer (hence referred to as 3D Sonic or sensor) measures three-dimensional wind speed, wind direction, and speed of sound based on the transit time of ultrasonic acoustic signals. These signals are used to calculate the meteorological parameters that are a known function of the air temperature and composition. Sonic temperature (or virtual temperature) is derived from speed of sound that is corrected for crosswind effects.

The 3D Sonic has no on-board data storage. Therefore, should the data acquisition system connected to the sensor fail or stop logging; there is no method to recover meteorological data. Electrical connections to the sensor are made via an easily accessible junction box. The unit mounts on standard 1-inch pipe, outside diameter 1 ¼" O.D.

### 1.3 Description of RM Young 81000 Ultrasonic Anemometers:

The 3D Sonic is a 3-axis, no moving parts wind sensor. It is well suited for applications requiring fast response with high resolution. The sensor features UV stabilized thermoplastic, stainless steel, and anodized aluminum components for excellent environmental resistance.

Measurement data are available as serial output using RS-232/485 or analog connections. Using serial connections (CARB standard), multiple output formats are available. The custom format allows the user to construct an ASCII-printable serial output string and is easily set by the user via a standard serial communication program.

The standard custom output string for CARB air monitoring operations is **"56789AB"** for UVW, 2D SPEED, 3D SPEED, Azimuth, Elevation, Speed of Sound, and Sonic Temperature where:

- UVW is the orthogonal u, v, and w wind velocities. Typically, the 3D Sonic is oriented with u-axis aligned East-West and v-axis aligned North-South. In this orientation, +u values = wind from the east, +v values = wind from the north. Wind from below (updraft) = +w.
- 2D SPEED is the wind magnitude in the u-v plane (the horizontal plane across the sensor).
- 3D SPEED is wind magnitude in three-dimensional space.
- AZIMUTH is the 0.0 - 359.9 degree wind direction angle in the u-v plane. Normal orientation is with the sensor's junction box facing South. (0.0 degrees = North, 90.0 degrees = East, 180.0 degrees = South, and 270.0 degrees = West).
- ELEVATION is the  $\pm 90.0$  degree wind elevation angle relative to the u-v plane. Values are positive when wind is from below (updraft) and negative when from above (downdraft). Effective elevation angle measurements are limited to  $\pm 60.0$  degrees.
- SOS is the speed of sound.
- Sonic Temperature (3DST) is the virtual temperature derived from SOS.

#### 1.4 Interferences and Safety Considerations:

##### High Wind Speed Measurements

For best measurement results, particularly at high wind speeds, always choose the lowest output rate possible. Lower output rates use a greater number of internal samples to generate results. If measuring for spectral content, carefully determine the needed sampling rate and use the lowest output rate necessary.

**NOTE: CARB standard configuration for the 3D Sonic is an output rate of two data points per minute. If the sensor's output rate is changed, CARBLogger may not properly process sub-minute data. Contact ODSS should the output rate need to be modified.**



### Rain and Snow

Anything that blocks the acoustic signal path will degrade the measurement. If the path is blocked sufficiently, measurements cannot be made. The 3D Sonic can make accurate measurements in driving rain even at high output rates, but light mist or heavy fog can allow droplets to accumulate on the transducer faces and block the measurement. Measurements may be made in driving snow although frost and snow that adheres to the transducer face may block the measurement. Similarly, freezing rain on the transducer face may block the measurement.

### Power Connections

Supply power must be in the range of 12 to 24 Volts DC at the sensor junction box terminals for the sensor to operate properly. For long cables, make sure to allow for voltage drop due to wire resistance.

### Met Tower Safety

Proper installation and siting of met towers determines the effectiveness of a system and ensures ease of maintenance and reliability. Climbing met towers to perform maintenance tasks is hazardous; use all necessary precautions as outlined in agency-specific Health and Safety Plans (HASPs).

#### 1.5 Personnel Qualifications:

Staff should be trained and familiar with basic air monitoring principles and procedures prior to operating any air monitoring equipment. Staff should complete any required safety training working in the field. Staff should review this SOP and complete any instrument related and air monitoring operations training required by their section manager prior to installing or working with the 3D sonic sensor.



*Figure 1: RM Young 81000 3D Sonic Sensor*

## **2.0 INSTALLATION PROCEDURE**

### 2.1 Installation Overview:

The 3D Sonic arrives from the factory calibrated and ready to use. Prior to field use, carefully unpack the sensor, inspect for physical damage, record the sensor's I.D. information, and date of last vendor calibration/test. Report any damage to the MLD stockroom or the ODSS Instrument Laboratory personnel.

### 2.2 Equipment Required for Installation:

- RM Young 81000 Ultrasonic Anemometer
- Power Supply, 12 to 24 Volt DC fixed output, and 500 mA minimum.
- Enough 18-to-24-gauge interconnect wiring to reach from the sensor mounting position to the power supply and data logger. The sensor interconnect will need an appropriate serial connector.
- Hand Tools, including, but not limited to the following:
  - Screwdrivers, flat and Philips, numbers 0, 1, and 2
  - Wrenches, fixed, and adjustable
  - Pliers, long nose
  - Pliers, diagonal cutting
  - Strippers, wire, 24 to 14 gauge
  - Bubble level
  - Magnetic Compass / Transit
- 1¼ inch O.D. pipe, to mount the 3D Sonic.
- Operator's Manual for the 3D Sonic.

### 2.3 Mounting the Sensor to an Existing Meteorological Tower:

Proper operation of any meteorological instrument is related to siting of the sensor. An ideal installation is one where the operator can safely access the sensor; perform tests adjacent to the electronics and recorder, and re-install the sensor, alone, within one hour. Site operators should review the U.S. Environmental Protection Agency (U.S. EPA), Quality Assurance Handbook for Air Pollution Measurement Systems, Volume IV to get a more detailed description of meteorological sensor siting requirements, installation procedures, and safety considerations.

Prior to mounting the sensor to the tower, procure a serial cable of enough length to allow the sensor to connect to the data logger. Secure a 1¼ inch O.D. alignment tube to the meteorological tower or sled assembly. Mount the 3D Sonic to a vertical piece of 1¼ inch diameter rigid tubing and attach it to the cross arm. If co-locating with another wind sensor, the center of the 3D Sonic should be at the same elevation as the other sensor. Maintain at least one-meter separation between sensors to minimize wake turbulence interference.



*Figure 2: Sensor Installation View*

## 2.4 Sensor Alignment to True North:

The 3D Sonic must be oriented to True North to accurately measure wind direction. The “**N**” indicator on the 3D Sonic alignment sticker must be facing True North to reference the sensor to True North. This can be accomplished when mounting the crossbar on which the sensor will be fixed onto the met mast. Mount the vertical stand to the crossbar, taking care to use a straight edge to align the 3D sonic mounting collar’s southern protuberance to the 90-degree mark on the orthogonal joint.

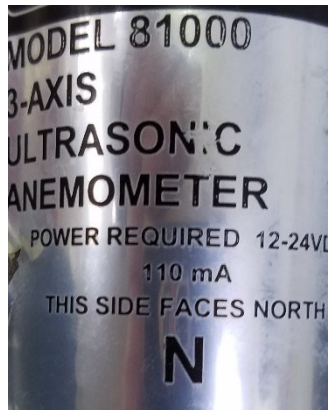

*Figure 3: Alignment Sticker*

Prior to installation, the station operator should be familiar with a site’s magnetic declination and operation of a surveying compass. U.S. EPA guidance requires that the sensors be aligned to  $\leq 2$  degrees with respect to the sensor mount ( $\leq 5$  degrees absolute error for the installed system).

**NOTE: Compass readings can be affected by metallic materials such as watches, belt buckles, knives, etc. All metallic materials must be kept away from the compass when alignment readings are taken.**



*Figure 4: Sensor Mounting Collar*

3D Sonic sensors should be oriented to True North as follows:

1. Adjust a compass or pocket transit for proper site magnetic declination. Attach the ball and socket head to a tripod and attach the compass to the socket, secure with clamp.
2. Position the tripod to get a clear and safe view of the sensor. **The best position is usually to the South of the met tower, in line with the mast, 10 to 30 meters from the mast facing North.**
3. Open the compass mirror to a 45-degree angle and set the front site perpendicular to the case. Level the compass by using the circular bubble level. The compass is correctly sighted on the sensor when the operator, while looking into mirror, sees the black centerline of the mirror bisecting both the front site and the cross arm or orientation vane. Check the bubble in the circular level to confirm that it is still level. The North seeking end of the needle should be pointing to  $0 \text{ degrees} \pm 0.5 \text{ degree}$ . If the correct declination is used and the compass is properly sited, the cross arm or alignment vane should be aligned to True North. To confirm that the sensor is properly aligned, it is

helpful to view the mast from the opposite side (180 degrees) of the orientation direction.

4. The use of an orientation pointer may make alignment of sensors to True North easier. If this is done, the pointer may appear parallel to the black bisecting centerline in the mirror.
5. Alignment of sensors is best done by two people, one person to orient the sensor and one person to read the compass.

## 2.5 Connecting to Data Loggers:

CARB standard configuration for the 3D sonic is to configure the instrument for digital output for the CARBLogger system. Section 2.7 and section 3.1 of this document discusses 3D sonic sensor configuration and connections to CARBLogger.

## 2.6 3D Sonic RS-232 Sensor Cable:

Prior to installing a 3D Sonic and connecting the sensor to CARBLogger, an RS-232 serial cable of enough length must be constructed. Sensor cables are typically assembled by the ODSS Instrument Lab at the request of field staff. Field staff should request a sensor cable with enough length to reach from the CARBLogger to the top of met tower with extra for a drip line.

RM Young 81000 sensors purchased by CARB do not include a power supply. A third-party adjustable 12 V DC power supply is used to provide power for the sensors. Power supplies for the 3D Sonics are configured prior to initial sensor deployment.

Some air monitoring sites in the network require long cable connections (greater than 100 feet). The voltage produced by power supplies at these sites may not be adequate to properly power the 3D Sonic. In these cases, it may require field staff to 1) measure the input voltage at the sensor and 2) adjust/increase the voltage output from the power supply.

To verify input voltage to the 3D Sonic, energize the power supply used to supply power to the sensor. Connect a digital voltmeter to the +PWR and PWR REF terminals of the 3D Sonic to check the input voltage. The input voltage should be at minimum 12 volts DC. If the voltage is too low, the sensor cable may be too long causing an excessive voltage to drop. An adjustment to the power supply output voltage may alleviate the problem.



*Figure 5: Checking 3D Sonic Input Voltage*



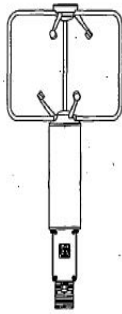

### RS-232 Connections

Factory default settings:

- 38400 baud, 1 start, 8 data, no parity, 1 stop bit, no flow control
- 789AB Custom ASCII Serial Output Format
  - 7 = 3D Wind Speed (m/s)
  - 8 = Wind Direction Angle (0-360°)
  - 9 = Wind Elevation Angle (-60 to +60°)
  - A = Speed of Sound (m/s)
  - B = Sonic Temperature (C°)
- Output Rate 4Hz
- Threshold 20 cm/s (0.2 m/s)
- Wake Correction Enabled
- Omit Invalid Data

See manual section 6.7 for SERIAL OUTPUT FORMAT options.

Verify shorting block jumpers at W5 and W6 as shown.

Use shielded cable. Connect cable shield to ground at one end only as shown. For maximum reliability, connect sensor Earth Ground as close to sensor as possible.

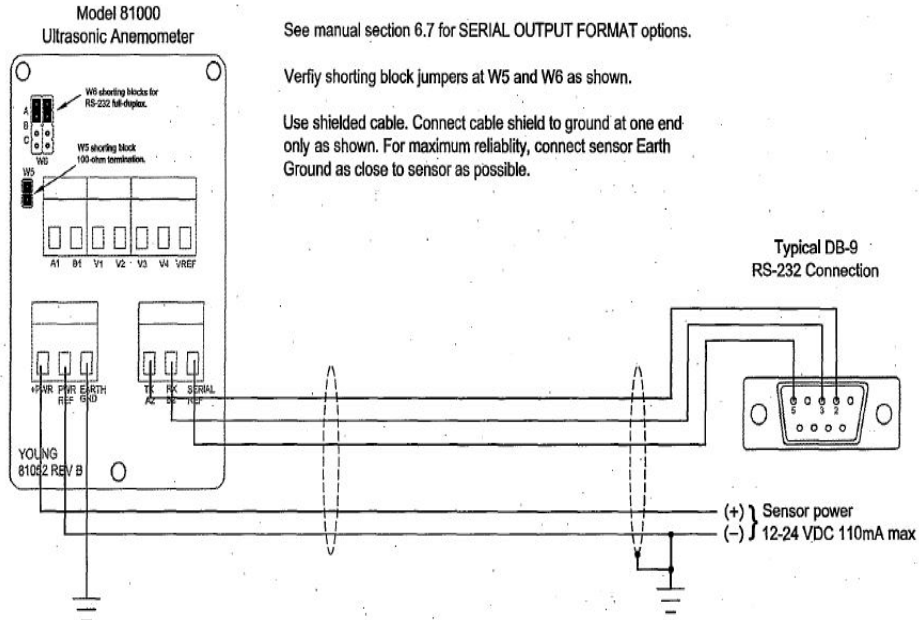

Figure 6: RM Young 81000 RS232 Connections

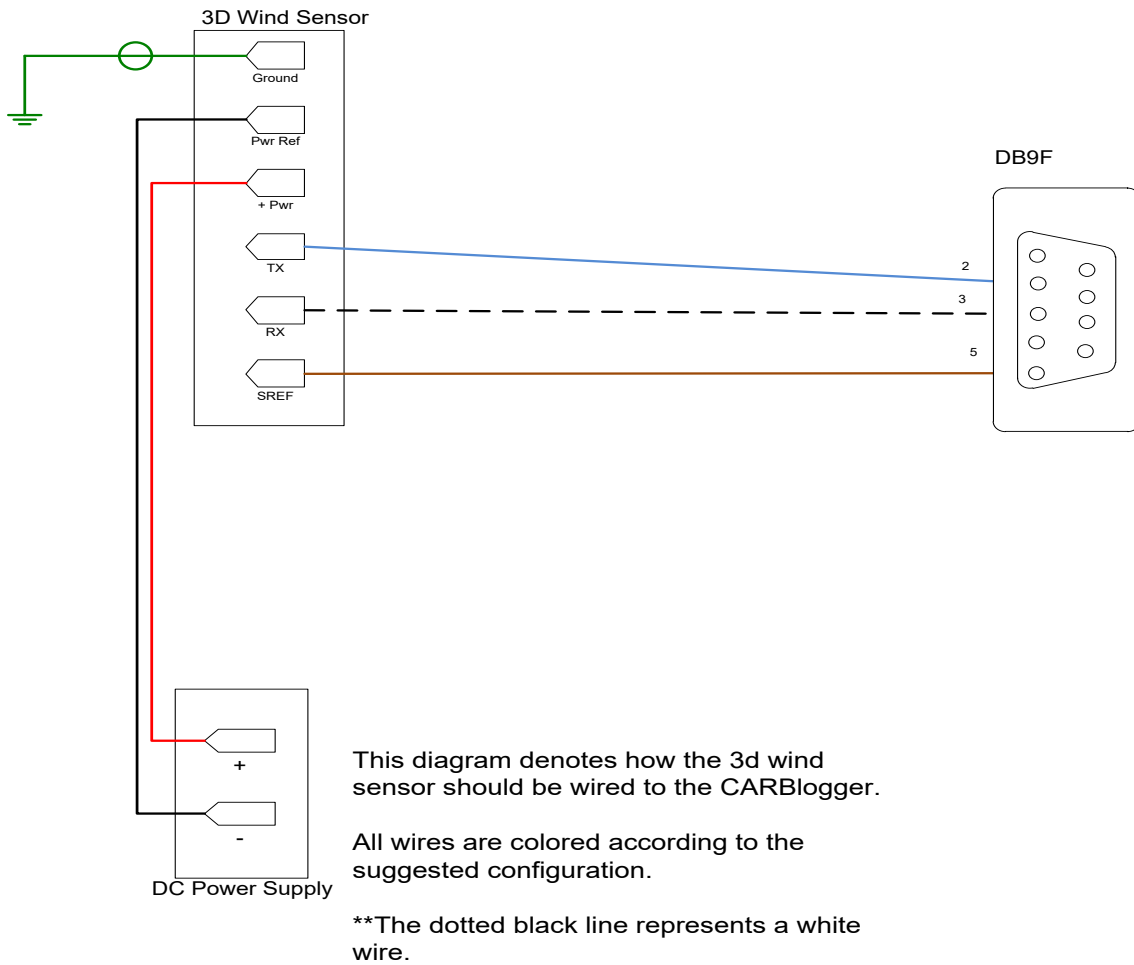

Figure 7: RM Young 81000 RS232 Wiring Diagram

## 2.7 3D Sonic Sensor Configuration:

Prior to connecting the 3D sonic to a CARBLogger, sensor parameters must be configured within the sensor using a communications application. These parameters are typically set by the ODSS Instrument Laboratory staff before deploying a sensor. However, should field staff need to configure a sensor or confirm a sensor setting, the steps below describe that process. The following sensor parameters must be set or configured in the sensor:

- Baud rate
- Output rate
- Serial out format
- Output data format
- Output units
- Error handling

Connect the 3D Sonic to a serial port of a laptop or computer and use a terminal program such as hyper-terminal, PuTTY, GtkTerm or similar application. This document illustrates using GtkTerm from the CARBLogger desktop. Set the terminal program to connect to the appropriate serial port using the default settings of 9600 baud, 8 data bits, no parity, and 1 stop bit. If you see data streaming onto the monitor or if the 3D Sonic displays a stream of unreadable characters after connecting, then you have found the right port. If there is a stream of unreadable characters, try switching the baud rate to 4800 or 19200 baud. If there are still unreadable characters, contact ODSS for assistance.

1. Press the [Esc] key, three times in rapid succession. This will cause a menu to appear.

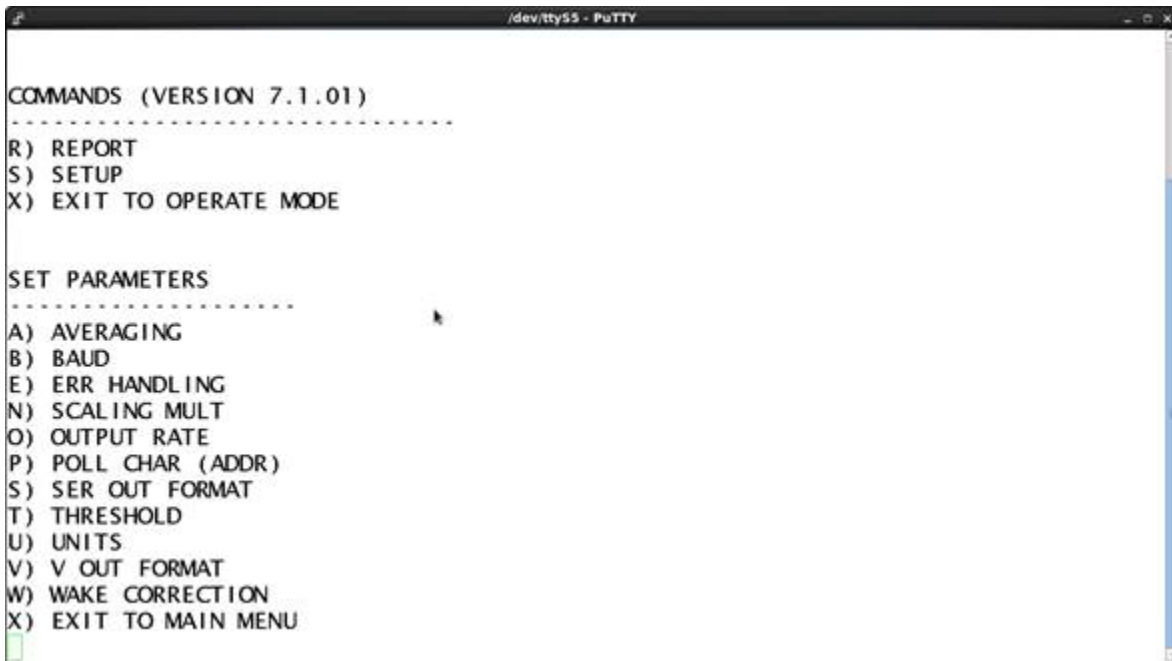

*Figure 8: RM Young 81000 Set-up Menu*

2. Next select [Setup] by typing "S."
3. Select "Averaging" by typing "A." Type "120" followed by enter to set an averaging interval of 120 samples.
4. Select "Baud Rate" by typing "B," and subsequently select 9600 by typing "D". The sensor will respond by requesting a duplex setting, select "2" for FULL Duplex.
5. Select "Output Rate" by typing "O," and subsequently select 4 Hz by typing "A".
6. Set the "Serial Out Format" by selecting "S," followed by "1" for "Custom".
7. Choose the following options: "56789AB" for UVW, 2D SPEED, 3D SPEED, Azimuth, Elevation, Speed of Sound, Sonic Temp.
8. Select "Units" by typing "U" and select "5" for knots, followed by enter.
9. Finally select "Err Handling" by typing "E," then select "2" to omit invalid data.

The CARBLogger RM Young 81000 driver was programmed to accept data and correct for line/signal errors while omitting invalid sub minute data points. Should transmission be malformed (based on data observed to date), CARBLogger should drop that line of data.

Under optimal conditions, the following string is a complete line of sub minute data that contains a check sum of "13" for the following values:

- two-digit hour
- two-digit minute
- two-digit second
- Nano-second stamp (where 0 would be the bottom of the second, and  $1 \times 10^9$  would be the top)
- U, V, W, 2D Speed, 3D Speed, Azimuth, Elevation, Speed of Sound, and Sonic temperature

13 14 55 33 609001231 2.0 -1.2 0.9 2.4 2.6 122.0 20.9 670.9 72.98

If the checksum does not equal 13, or the speed of sound token is less than 600, that line will be discarded from the one-minute average. If one to three sub-minute values are collected for any single minute, the average of all values will be recorded in the CARBLogger data record for that minute. The above file would be located at the following location:

**`"/home/aqdms/CARBLog/resources/RMYOUNG30SEC_drv/14/55.dat"`**

If no valid data points are collected for a single minute, no minute data is recorded to the CARBLogger data file, and an error is reported to the site operator letting them know why they missed data.

If the CARBLogger is configured incorrectly, the driver may be unable to remove data files, hence causing too many lines of sub-m data to be collected. In this case, no minute data value is recorded, and an error is reported to the operator letting them know why they missed data.

**NOTE: If the CARBLogger is misconfigured or no valid data is received, CARBLogger will notify the operator with the following message *"The RMYoung data was not aggregated for this minute because of too few valid data points."***

### 3.0 DATA ACQUISITION AND CONFIGURATION

#### 3.1 CARBLogger Configuration:

Prior to using the 3D Sonic, the RM Young 81000 driver must be enabled on the CARBLogger. To add or verify the proper 3D sonic driver, select “Add Driver” from the CARBLogger user interface. Verify the proper driver is installed or add the “RMYOUNG30SEC\_drv” driver.

**NOTE: The driver labeled “RMYOUNG81000\_drv” is a legacy driver and is incompatible with the current CARB 3D sensor configuration. If the “RMYOUNG81000\_drv” is active, it must be removed from the CARBLogger and the “RMYOUNG30SEC\_drv” driver must be added.**

The RM Young driver was developed by evaluating various RS232 serial cable lengths and baud rates. For most, if not all, CARB installations, a sensor output interval of two points per minute and 9600 baud rate are optimal. Normally configured, the 3D Sonic ideally collects two valid data points per minute. The following steps will allow operators to evaluate standard sensor configurations for their monitoring stations. This test should be performed prior to installing the sensor to the met tower.

1. Connect the 3D Sonic to an available serial port on the CARBLogger.
2. Start the CARBLogger with the 3D Sonic configured as discussed in Section 2.7 “3D Sonic Sensor Configuration” to an output rate of two data points per minute.

**NOTE: AQSB standard configuration for the 3D Sonic is for an output rate of two (2) points per minute. If the sensor output rate is changed to something other than two (2) points per minute, the CARBLogger may not properly process sub-minute data. Contact ODSS should the sensor output rate need to be modified.**

3. Open a shell terminal by clicking on the menu button and choosing the “Terminal” icon.
4. Once in the terminal window, type the following command replacing [HH] with the present two-digit military hour (in PST). For instance, we ran this at 3:00 PM, so we replaced [HH] with “15”:

```
wc -l /home/aqdms/CARBLog/resources/RMYOUNG30SEC/[HH]/*.dat
```

*Figure 9: CARBLogger "Query" Command*

5. The output is a series of line count numbers adjacent to .dat file names as shown below.

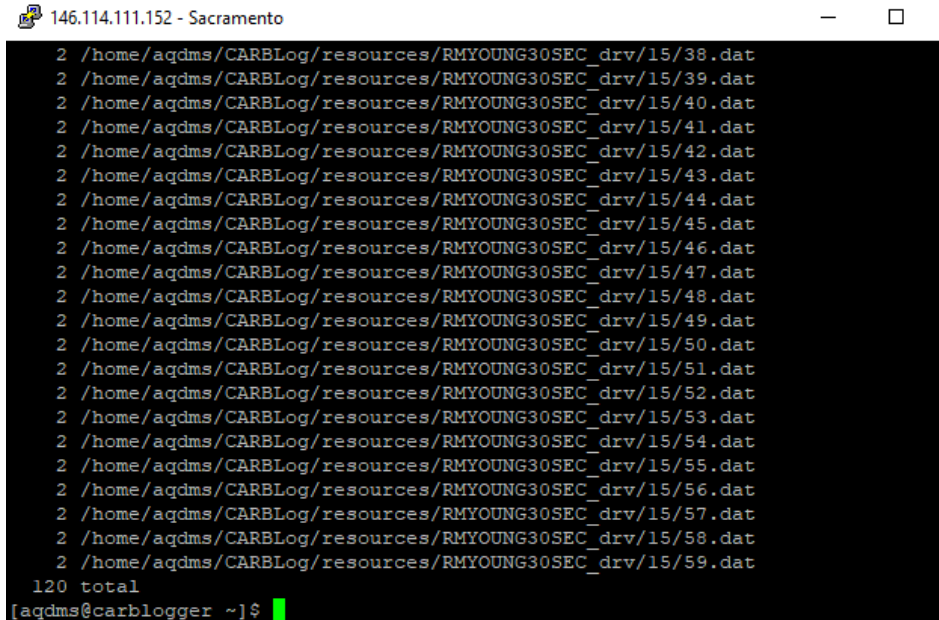

```
146.114.111.152 - Sacramento
2 /home/aqdms/CARBLog/resources/RMYOUNG30SEC_drv/15/38.dat
2 /home/aqdms/CARBLog/resources/RMYOUNG30SEC_drv/15/39.dat
2 /home/aqdms/CARBLog/resources/RMYOUNG30SEC_drv/15/40.dat
2 /home/aqdms/CARBLog/resources/RMYOUNG30SEC_drv/15/41.dat
2 /home/aqdms/CARBLog/resources/RMYOUNG30SEC_drv/15/42.dat
2 /home/aqdms/CARBLog/resources/RMYOUNG30SEC_drv/15/43.dat
2 /home/aqdms/CARBLog/resources/RMYOUNG30SEC_drv/15/44.dat
2 /home/aqdms/CARBLog/resources/RMYOUNG30SEC_drv/15/45.dat
2 /home/aqdms/CARBLog/resources/RMYOUNG30SEC_drv/15/46.dat
2 /home/aqdms/CARBLog/resources/RMYOUNG30SEC_drv/15/47.dat
2 /home/aqdms/CARBLog/resources/RMYOUNG30SEC_drv/15/48.dat
2 /home/aqdms/CARBLog/resources/RMYOUNG30SEC_drv/15/49.dat
2 /home/aqdms/CARBLog/resources/RMYOUNG30SEC_drv/15/50.dat
2 /home/aqdms/CARBLog/resources/RMYOUNG30SEC_drv/15/51.dat
2 /home/aqdms/CARBLog/resources/RMYOUNG30SEC_drv/15/52.dat
2 /home/aqdms/CARBLog/resources/RMYOUNG30SEC_drv/15/53.dat
2 /home/aqdms/CARBLog/resources/RMYOUNG30SEC_drv/15/54.dat
2 /home/aqdms/CARBLog/resources/RMYOUNG30SEC_drv/15/55.dat
2 /home/aqdms/CARBLog/resources/RMYOUNG30SEC_drv/15/56.dat
2 /home/aqdms/CARBLog/resources/RMYOUNG30SEC_drv/15/57.dat
2 /home/aqdms/CARBLog/resources/RMYOUNG30SEC_drv/15/58.dat
2 /home/aqdms/CARBLog/resources/RMYOUNG30SEC_drv/15/59.dat
120 total
[aqdms@carblogger ~]$
```

*Figure 10: CARBLogger Display*

6. If the line count numbers you receive are from 1-3, then two (2) points per minute and 9600 baud are the appropriate output rate and baud rate for your installation. If the line count number is greater than three or less than one (in which case the CARBLogger display shows that no data was received), then contact ODSS staff. The use of a shorter RS232 cable or adjustment to the sensor's baud may be required.

## 4.0 SENSOR CERTIFICATION

### 4.1 Introduction:

All 3D Sonic sensors used in the CARB's ambient monitoring network must be returned to the manufacturer periodically to ensure and maintain proper operation of the sensor. The sensor is calibrated and evaluated at the factory utilizing a wind tunnel and proprietary algorithms to compensate for certain inefficiencies in sampling. Wind tunnel calibrations are conducted at different wind speeds utilizing a NIST traceable wind speed standard.

### 4.2 RM Young 81000 Certification and Calibration Frequency:

Upon receipt of a new sensor or after return from factory for calibration, a Certificate of Calibration and Testing (Figure 11) is received. The Certificate of Calibration and Testing will display a date of certification. This date is the actual date of sensor calibration and testing by the manufacturer. Based on past sensor performance, amount of sensor usage, acceptable tolerance, and manufacturer's recommendations: RM Young has stated CARB may establish a policy that the RM Young Model 81000 3D Sonic Certificate of Calibration and Testing for CARB operated sensors is effective for **two** years after the date of certification. However, RM Young recommends that sensors only be actively deployed to field locations for a period of **one** year (Appendix B).

Upon receiving a new or recently calibrated sensor, operators should check the certification and testing date on the associated Certificate of Calibration and Testing document. The 3D sonic may be installed in the field anytime during the two-year certification period but must not be used more than one year from the date of sensor installation. The one-year field use period must be bracketed by the sensor's two-year certification window.





**CERTIFICATE OF CALIBRATION AND TESTING**

**SERIAL NUMBER:** UA00003805

**CUSTOMER:** CALIFORNIA AIR RESOURCES BOARD  
**P.O. NUMBER:** ARB125232  
**INV NUMBER:** 121899  
**MODEL:** 81000 ULTRASONIC ANEMOMETER - 3 AXIS

We hereby certify that the sensor serial number specified above has been calibrated, tested, and found to comply with the following Wind Speed Accuracy Specification from 0 to 30 m/s.

Average wind speed plus standard deviation of wind speed are within 1% +/- 0.5 m/s of a wind speed reference. Data are collected at nominal speeds of 6 and 30 m/s.

Standards established by R. M. Young Company for calibrating the measuring and test equipment used in controlling product quality are traceable to the National Institute of Standards and Technology (NIST).

Date of Certification: 17 May 2013

R. M. Young Company  
*E Chemosky*  
Ed Chemosky  
Quality Assurance

**R. M. YOUNG COMPANY** 2801 Aero Park Drive, Traverse City Michigan 49686-9171 USA  
TEL: (231) 946-3980 FAX: (231) 946-4772 Email: met.sales@youngusa.com

Figure 11: Certificate of Calibration and Testing

#### 4.3 Sensor Replacement Process:

The U.S. EPA Quality Assurance Handbook for Air Pollution Measurement Systems, Volume IV: Meteorological Measurements states an annual requirement for the calibration/verification frequency for wind measurement system used at SLAMS sites. To meet this requirement, CARB has set a policy that 3D sonic sensors used in the ambient air monitoring network are replaced within one year from installation or before sensor certification expiration, whichever date comes first.

The following steps outline the process for sensor replacement at CARB air monitoring sites:

- a. Site operators must notify their ODSS contact 4 - 6 weeks prior to needing a replacement sensor. This request can be via e-mail, phone, or in person. During data review, the second level data reviewer should review monthly QC forms and monitor the sensor replacement date. If noted that the sensor replacement date is approaching, confirm with the site operator that a new sensor has been requested.
- b. ODSS staff will prioritize replacements based on expiration dates and operator's compliance with 4 - 6 weeks notification, NOT on "first requested first served".
- c. ODSS staff will contact the site operator when a replacement sensor will be shipped.
  - i. If a sensor is available when a replacement is requested, the sensor will be shipped as soon as possible after receiving the request and no less than three weeks prior to field unit expiration date.
  - ii. If no sensors are available at the time a request is made, an estimated date of shipment should be given. ODSS staff must keep a "waiting list" prioritized on field unit expiration dates. ODSS staff must contact the operator when a new certified unit is available for shipment.
- d. Site operators must commit to install replacement sensors within two weeks of receipt. If replacement is not possible, the sensor should be returned to ODSS for re-deployment to another location. A new shipment date will be scheduled for the original request.

- e. Site operators should coordinate with their supervisor to arrange for any assistance or special equipment (i.e., boom truck) they may need to remove an expired sensor and install a new sensor.
- f. Site operators must return the expired sensor to ODSS within one week of installing a replacement sensor. Monitoring managers should monitor sensor replacement status to ensure sensors are returned in a timely manner.
- g. Site operators must note on the weekly status report that the new sensor has been installed. In addition, site operators should notify designated ODSS contact of sensor installation dates for tracking purposes. It is recommended that site operators use Outlook Calendar to notify all necessary parties.
- h. Site operators must document the installation and expiration dates on AQSB QC Form 506 (Appendix A).

#### 4.4 Factory Return Process:

Certification and repair service for RM Young 3D sonic sensors is now covered via the Department of General Services Equipment Maintenance Management Insurance Program (EMMP). The Remi Group (hence referred to as REMI) administers this service. The following steps describes the process for AQSB staff to return 3D sonic sensors for certification. The REMI contract covers one (1) certification per year for each RM Young 3D sonic sensor owned by AQSB.

The following steps outline the process for returning the 3D sonic sensors for certification/repair service:

- a. Site operators must notify the ODSS REMI contract lead, 6 - 8 weeks prior to needing a replacement sensor. This request can be via e-mail, phone, or in person. Upon request for a replacement sensor, include the following information for the sensor you are returning:
  - Sensor serial number (SN) or CARB RFID/Barcode
  - Type of service requested (certification or repair and certification)
  - If repair is requested, a brief description of the sensors malfunction, or problem.
- b. ODSS REMI contract lead will submit a request for certification/repair

service to REMI dispatch email ([Dispatch@theremigroup.com](mailto:Dispatch@theremigroup.com)). This request should use the REMI asset number of the sensor and list RM Young as the vendor.

- c. REMI will contact the ODSS REMI contract lead and provide the return merchandise authorization number (RMA), a blank RM Young RMA Form, and a REMI Contract Service Request (CSR).
- d. ODSS REMI contract lead will complete the RM Young RMA form. The contract lead will forward the completed RMA form to ODSS instrument lab staff and MLD Admin stockroom personnel to coordinate shipping of the 3D sonic sensor.
- e. Upon completion of certification/repair, the sensor will be returned to CARB via the MLD Admin stockroom. MLD Admin stockroom personnel will return the sensor the ODSS contract lead or ODSS stockroom staff. Sensors will be stored by ODSS until needed for field use.

## **5.0 OPERATIONAL AND ROUTINE SERVICE CHECKS**

### 5.1 Daily (or each site visit) Checks:

Review RM Young sensor data on DMS from previous day(s) for accuracy and completeness.

### 5.2 Weekly Checks:

Visually check the sensor and/or sensor's transducers for physical damage or sensor orientation/alignment changes.

### 5.3 Monthly Checks:

Perform a visual check of current wind parameters. Measure wind speed and direction using a portable wind sensor and compare observations to data logger results. Results should be comparable with no more than 10% of difference. If results are not comparable, the sensor should be checked for obstructions or damage and all cables and connections should be checked for problems. If no problems are observed, the sensor should be replaced and/or sent to the manufacturer for repairs.

### 5.4 Semi-Annual Checks:

Sensor alignment with respect to True North should be checked. Alignment should be within +/- 5 degrees of True North. If not, the sensor should be re-aligned. Clean sensor with a clean dry cloth and water.

### 5.5 Annual Checks:

Replace 3D Sonic with certified sensor and return "old" sensor to ODSS. The new sensor's expiration date is TWO years from the date indicated on the Certificate of Certification and Testing or one year from installation, whichever comes first.

## **6.0 MAINTENANCE PROCEDURES**

### 6.1 General Information:

Ultrasonic sensors should be checked periodically for any dirt or debris (aviary or insect) and gently cleaned, if necessary, using a clean dry cloth and water. The sensors should be checked for physical damage to the array assembly, cable, and cable connections. All transducers should be inspected to insure they are securely fastened.

## 7.0 TROUBLESHOOTING

### 7.1 General Information:

The 3D Sonic, having no moving parts, when properly configured, is typically problem free and requires little if any maintenance. Most problems associated with the sensor manifest themselves as problems with the data (no data reported, data gaps, or abnormal data readings). Most data related problems with the 3D Sonic are the result of improper configurations within the CARBLogger and/or DMS. Refer to AQSB SOP 605 and/or 606 to address data issues relating to CARBLogger or DMS.

Before starting any troubleshooting procedure, refer to the 3D Sonic operating manual for specific information pertaining to troubleshooting. Record malfunctions, repairs, and actions taken to prevent recurrence of any malfunction on the Monthly Quality Maintenance Checksheet (Appendix A).

Troubleshooting should attempt to isolate the source of the malfunction and reduce maintenance time. The following items should be checked if a problem exists:

1. Visually inspect sensor alignment and sensor condition.
2. Check for signs of birds, insects, or wildlife.
3. Verify that there is no damage to the transducer assembly.
4. Check for loss of voltage supply.
5. Verify that the cable connections are secure.
6. Compare visual estimates of wind parameters with outputs from the data logger.
7. Verify proper CARBLogger initialization.

### 7.2 Common Issues:

Common sensor issues typically encountered are shown in the table below. In general, the solutions to these issues are to:

- Inspect the sensor to verify that transducers are clean.
- Check that all wires and connections are secure.

- Ensure power to the sensor is adequate.

A review of CARBLogger diagnostic e-mails will indicate whether the sensor is generating enough sub-minute data to properly report meteorological data. Contact ODSS staff for additional support to identify a cause of a 3D Sonic issue.

<b>Issue</b>	<b>Problem(s)</b>
Random missing 1-minute WS, WD, or 3DST data	<ul style="list-style-type: none"> <li>• Obstructions to sensor’s transducers</li> <li>• Poor power to sensor</li> <li>• Loose connections in sensor</li> <li>• Malfunctioning sensor</li> </ul>
Large blocks of missing data	<ul style="list-style-type: none"> <li>• Obstructions to sensor’s transducers</li> <li>• Look for evidence of birds on sensor</li> </ul>
Momentary or sudden drops in 3DST data	<ul style="list-style-type: none"> <li>• Obstructions to sensor’s transducers</li> <li>• Look for evidence of birds on sensor</li> </ul>
Abnormal daily increases in wind speed or 3DST data	<ul style="list-style-type: none"> <li>• Malfunctioning sensor</li> </ul>

*Table 1. Common Issues and Possible Solutions*



## **8.0 QUALITY CONTROL AND ASSURANCE**

### 8.1 General Information:

CARB has established a robust QA/QC assurance program. The program ensures that ambient air monitoring data collected by CARB is high quality and complies with procedures and regulations set forth by the U.S. EPA.

More guidance regarding meteorological measurements can be found in the U.S. EPA QA Handbook for Pollution Measurement Systems Volume IV (Meteorological Measurements).

CARB staff should refer to AQSB SOP 606 Data Validation and Review for more detailed guidance regarding data validation and review. Data review and validation for meteorological parameters should parallel procedures used to validate gaseous and PM continuous parameters.

### 8.2 Quality Control:

The procedures outlined in this document set forth procedures to ensure that 3D sonic operations are conducted consistently and in accordance with federal requirements. QC maintenance checks for the 3D Sonics should be documented on monthly QC sheets and station logbooks.

### 8.3 Quality Assurance:

When instruments are found to be operating outside CARB's Performance Criteria, a corrective action notification (CAN) or Air Quality Data Action (AQDA) request may be issued.

## **REFERENCES**

RM Young Model 81000 Ultrasonic Anemometer (Rev F012407) Operating Manual.  
Prepared by R.M. Young Company

U.S. EPA, (2008) Quality Assurance Handbook for Air Pollution Measurement Systems, Volume IV: Meteorological Measurements (Version 2.0). Prepared by Office of Air Quality Planning and Standards

California Air Resources Board, (2018) CARBLogger Standard Operating Procedures, AQSB SOP 605, Prepared by the Operations and Data Support Section

California Air Resources Board, (2019) Data Validation and Review Standard Operating Procedures, AQSB SOP 606, Prepared by the Operations and Data Support Section

California Air Resources Board, (2020) Corrective Action Notification Standard Operating Procedures, Prepared by the Quality Management Section

**Appendix A: Monthly Quality Maintenance Checksheet for Ultrasonic Anemometer**

CALIFORNIA AIR RESOURCES BOARD  
 MONTHLY QUALITY MAINTENANCE CHECKSHEET  
 ULTRASONIC ANEMOMETERS

Location: \_\_\_\_\_ Month/Year: \_\_\_\_\_  
 Station Number: \_\_\_\_\_ Operator: \_\_\_\_\_  
 Property Number: \_\_\_\_\_ Agency: \_\_\_\_\_

OPERATOR'S INSTRUCTIONS:

- 1) Daily Checks: Review data logger results from previous day for consistency.
- 2) Weekly Checks: Visually check sensor, cables, met tower etc. for physical damage. Visually inspect sensor orientation/alignment.
- 3) Monthly Checks: Perform a visual check of current wind parameters. Estimate wind speed and direction and compare observations to data logger results. If results not within reason, then check for obstructions or damage. Check cables and connections for problems.
- 4) Semi-Annual Checks: Check sensor for alignment with respect to true north. If alignment is not within +/- 5 degrees of True, re-align sensor.
- 5) Annual Checks: Replace sensor and return to Operations and Data Support.

Sensor certification and testing date: \_\_\_\_\_

Sensor certification expiration date: \_\_\_\_\_

Sensor site installation date: \_\_\_\_\_

Sensor site replacement date: \_\_\_\_\_

Date	Comments or Maintenance Performed

Reviewed by: \_\_\_\_\_

Date: \_\_\_\_\_

## Appendix B: RM Young Calibration Frequency Memo



**R.M. Young Company**  
2801 Aero Park Drive  
Traverse City, Michigan 49686 USA

1 October 2016

To Whom It May Concern

**Subject: Frequency of Calibration for R.M. Young Company Manufactured Products**

Unless otherwise stated in instruction manuals R.M. Young Company recommends a calibration frequency of one year from the date of previous calibration or from sensor installation date for all sensors manufactured/calibrated at our facility. This calibration frequency may be affected due to local governing bodies, amount of sensor usage, and the acceptable tolerance based on customer's requirements. We suggest that a recalibration not exceed one year from the date of installation or two years from the date of previous calibration.

Please feel free to contact us should you have further questions.

Sincerely,

A handwritten signature in black ink, appearing to read "A. Oliver", is written over a light blue horizontal line.

Andy Oliver  
Sales Manager

METEOROLOGICAL INSTRUMENTS

Tel: 231-946-3980 Fax: 231-946-4772 Email: [met.sales@youngusa.com](mailto:met.sales@youngusa.com) Website: [www.youngusa.com](http://www.youngusa.com)