

**Executive Order VR-203-AD and VR-204-AD
Balance Phase II EVR System**

EXHIBIT 14

**Franklin Fueling Systems Healy Clean Air Separator
Static Pressure Performance Test Procedure**

Definitions common to all certification and test procedures are in:

D-200 Definitions for Vapor Recovery Procedures

For the purpose of this procedure, the term "ARB" refers to the California Air Resources Board, and the term " ARB Executive Officer" refers to the ARB Executive Officer or his or her authorized representative or designate.

1. PURPOSE AND APPLICABILITY

This test procedure is used to quantify the vapor tightness of the Healy Clean Air Separator (CAS) pressure management system installed as part of a gasoline dispensing facility (GDF) under Executive Order VR-203 and VR-204.

2. PRINCIPLE AND SUMMARY OF TEST PROCEDURE

- 2.1. The Clean Air Separator, while isolated from the vapor recovery system, is evaluated for vapor integrity using a vacuum decay procedure. The vacuum decay after 5 minutes is compared with an allowable value. The allowable value is based upon the initial vacuum level when conducting the test using the table provided in this test procedure.
- 2.2. A positive pressure decay procedure is included that conducts the same evaluation as the vacuum decay but with positive pressure. This test is conducted if there is insufficient vacuum (not greater than - 2.00" wc) to conduct the vacuum decay. Districts have the authority to specify in the permit conditions that this positive pressure test is to be conducted even if the vacuum test has been conducted.

3. RANGE

The full-scale range of the electronic measuring device shall not exceed 0-20.00"wc with a minimum accuracy of not less than 0.25 percent of full-scale.

4. INTERFERENCES

- 4.1. Leaks in the piping for the Clean Air Separator could bias the test results toward non-compliance.
- 4.2. Introduction of gaseous nitrogen into the system at flow rates exceeding 4 CFM (240 CFH) may bias the results of the test toward non-compliance. Only gaseous nitrogen shall be used to conduct this test.

4.3. Pressurizing the Clean Air Separator bladder greater than 14.00" wc could damage the bladder, biasing the test toward non-compliance.

4.4. Thermal Bias for Electronic Manometers

Electronic manometers shall have a warm-up period of at least 15 minutes followed by a drift check of 5 minutes. If the drift exceeds 0.01" wc, the instrument should not be used.

5. APPARATUS

5.1. Nitrogen

Use commercial grade gaseous nitrogen in a high pressure cylinder, equipped with a two-stage pressure regulator.

5.2. Pressure Measurement Device

A digital (electronic) manometer with 0.01 inches WC, or better resolution. The sensor must have a minimum measuring range of +/- 10 inches WC. The sensor must also be accurate to 0.05 inches WC for any pressure measurement made during the prescribed tests. For a manometer with a +/- 10 inches WC measurement range, this requires a 0.25% basic accuracy.

5.3. Test Port Assembly

Use a test port assembly constructed similar to the one in Figure 14-1. The assembly should have an 8 oz. Pressure Relief valve, to ensure that the Clean Air Separator is not over pressurized. The Model 9968 Clean Air Separator Test Port Assembly can be purchased from Healy Systems, Inc.

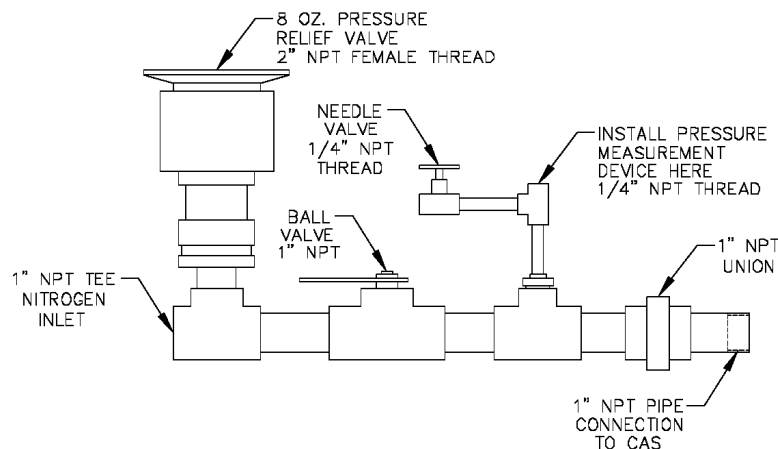

FIGURE 14- 1

Clean Air Separator Test Port Assembly

5.4. Stopwatch

Use a stopwatch accurate to within 0.2 seconds.

5.5. Flow Meter

Use a flow meter to determine the required pressure setting of the delivery pressure gauge on the nitrogen supply pressure regulator. This pressure shall be set such that the nitrogen flow rate is between 2.0 CFM (120 CFH) and 4.0 CFM (240 CFH).

5.6. Leak Detection Solution

Any liquid solution designed to detect vapor leaks may be used to verify the pressure integrity of the test equipment prior to conducting the test.

5.7. Condensate Collection Vessel

A container approved for use with gasoline that can hold at least a half gallon of material.

5.8. Graduated Cylinder

A graduated cylinder that is suitable for use with gasoline and capable of measuring to the nearest ounce or ml.

6. PRE-TEST PROCEDURE

6.1. The following safety precautions shall be followed:

6.1.1 Only gaseous nitrogen shall be used to pressurize the system.

6.1.2 An 8 oz. pressure relieve valve shall be installed on the Test Port Assembly to prevent the possible over-pressurizing of the Clean Air Separator.

6.1.3 A ground strap should be employed during the introduction of nitrogen into the system.

6.2. There shall be no Phase I bulk product deliveries into or out of the gasoline storage tank(s) within the three (3) hours prior to the test or during the performance of this test procedure.

6.3. A copy of the most current calibration shall be kept with all equipment. All electronic pressure measuring devices shall be bench tested for accuracy using a reference gauge, incline manometer or National Institute of Standards and Technology (NIST) traceable standard at least once every 180 consecutive days. Accuracy checks shall be performed at a minimum of three (3) points (e.g., 20, 50 and 80 percent of full scale) each for both

positive and negative pressure readings. Accuracy shall meet the requirements of Section 4.

- 6.4. Use the flow meter to determine the nitrogen regulator delivery pressures that correspond to nitrogen flow rates of 2.0 CFM (120 CFH) and 4.0 CFM (240 CFH). These pressures define the allowable range of delivery pressures acceptable for this test procedure. The flow meter shall be connected in-line between the nitrogen supply regulator and the Test Port Assembly during pressurization. The flow meter may be connected in-line between the nitrogen supply regulator and the Test Port Assembly during the test.
- 6.5. The electronic pressure measurement device shall be subject to warm-up and drift check before use; see Section 4.5.
- 6.6. The four ball valves used in the installation of the Clean Air Separator are lockable and shall be locked in the position shown in Figure 14-2 or Figure 14-2H of this Exhibit during normal operation. Figure 14-2 applies to vertical CAS installations and Figure 14-2H applies to horizontal CAS installations. The four padlocks provided by Healy Systems, Inc. in their installation kit are keyed the same. However, it is possible that one or more of the padlocks on the Clean Air Separator could have been replaced (seizing, damage, broken key, etc.). Conducting this test will require a set of keys necessary to unlock all padlocks.
- 6.7. Verify that the Clean Air Separator is in its normal operating configuration by confirming that all components are as indicated (See Figure 14-2 or Figure 14-2H):

- Valve "A" - Open
- Valve "B, C and D" - Closed
- Pipe End "E" - Plugged
- Tee Branch "F" - Plugged

FIGURE 14-2

Normal Clean Air Separator Operating Configuration

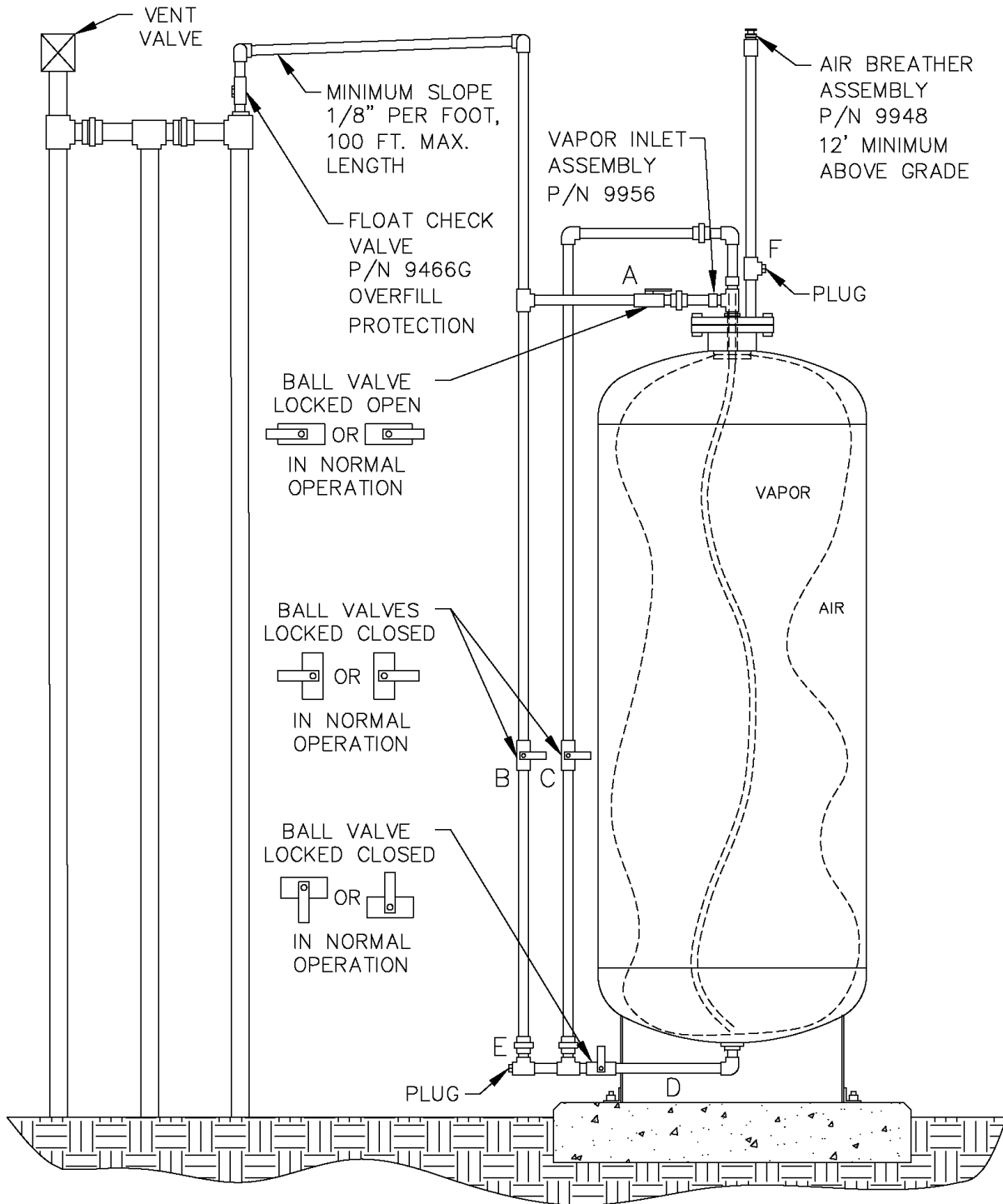
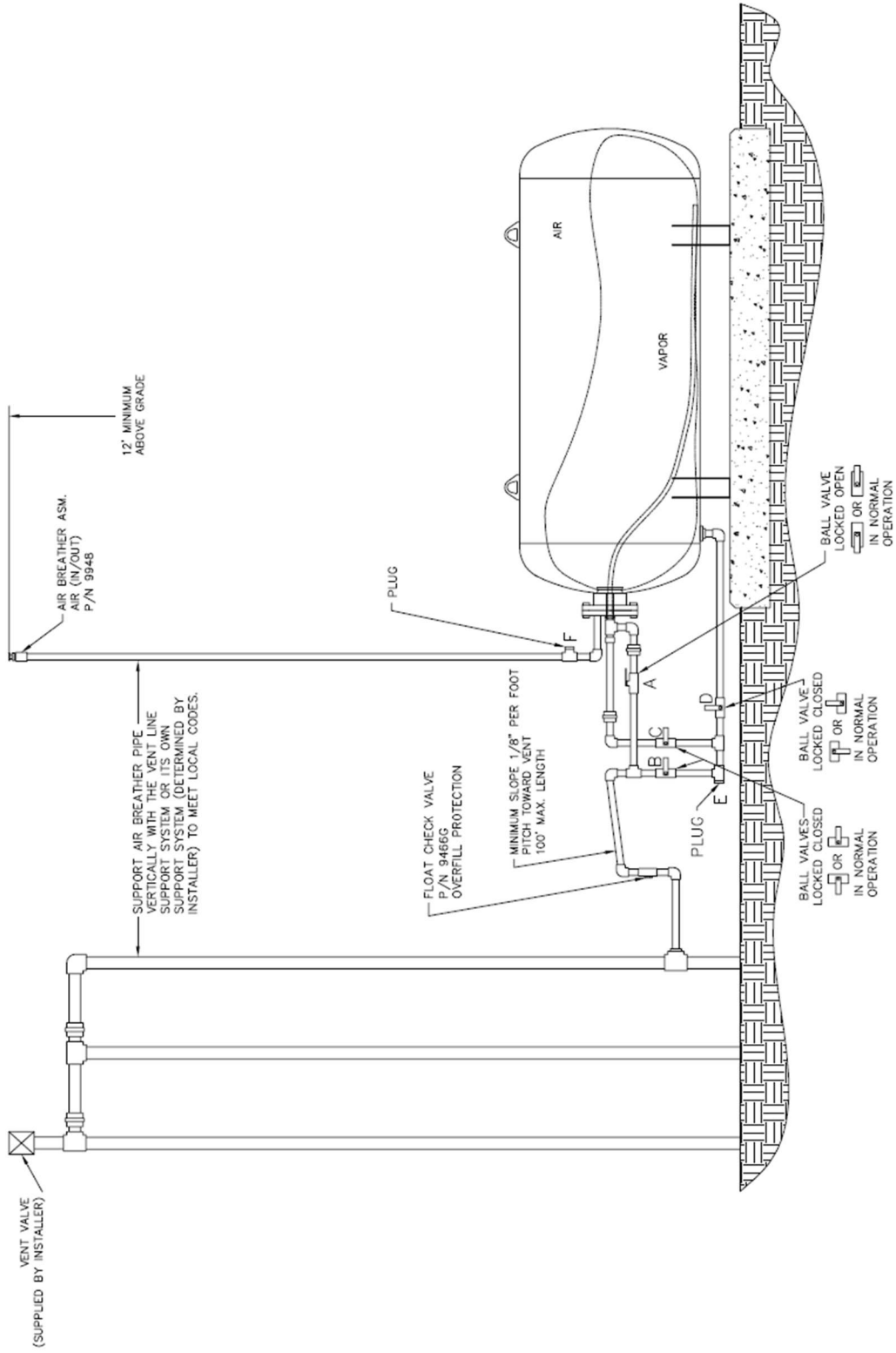

FIGURE 14-2H
Normal Clean Air Separator Operating Configuration



6.8. Installing the Test Port Assembly

- 6.8.1 Open the ball valve marked "B", shown in Figure 14-2 or Figure 14-2H. This ensures that if there is any condensate in the primary connection line to the Clean Air Separator it will drop down into the lower section of the piping configuration, so that it can be measured. Close the valve after approximately 30 seconds.
- 6.8.2 Position the condensate collection vessel below plug "E" prior to removing it. Remove the 1" plugs from locations "E" and "F" from Figure 14-2 or Figure 14-2H. Transfer the collected condensate into the graduated cylinder. If there is more than 16 oz. (473 mL) of liquid condensate, the bladder and vapor processor vessel must be drained. Conduct the bladder and vessel draining procedures from the Clean Air Separator section of the **ARB Approved Installation, Operation and Maintenance Manual**.

NOTE: Depending upon the size of the graduated cylinder and the amount of condensate, it may take multiple transfers from the condensate collection vessel to get the total condensate measurement.
- 6.8.3 Install the Test Port Assembly to the Clean Air Separator at location "E". See Figure 14-3 or Figure 14-32H. Figure 14-3 applies to vertical CAS installations and Figure 14-3H applies to horizontal CAS installations.
- 6.8.4 Connect the gaseous nitrogen supply to the Test Port Assembly. See Figure 14-3 or Figure 14-3H.
- 6.8.5 Check the test equipment and piping isolated from normal Clean Air Separator operation by the ball valves "B, C and D" by pressurizing with nitrogen to a pressure of 4" wc \pm 1" wc and closing the ball valve on the Test Port Assembly. Use leak detection solution. Tighten as necessary. The test equipment shall have no leaks.
- 6.8.6 Open the needle valve on the Test Port Assembly to bleed the pressure off the equipment. Keep ball valve on Test Port Assembly closed.

FIGURE 14-3

Normal Clean Air Separator Operating Configuration

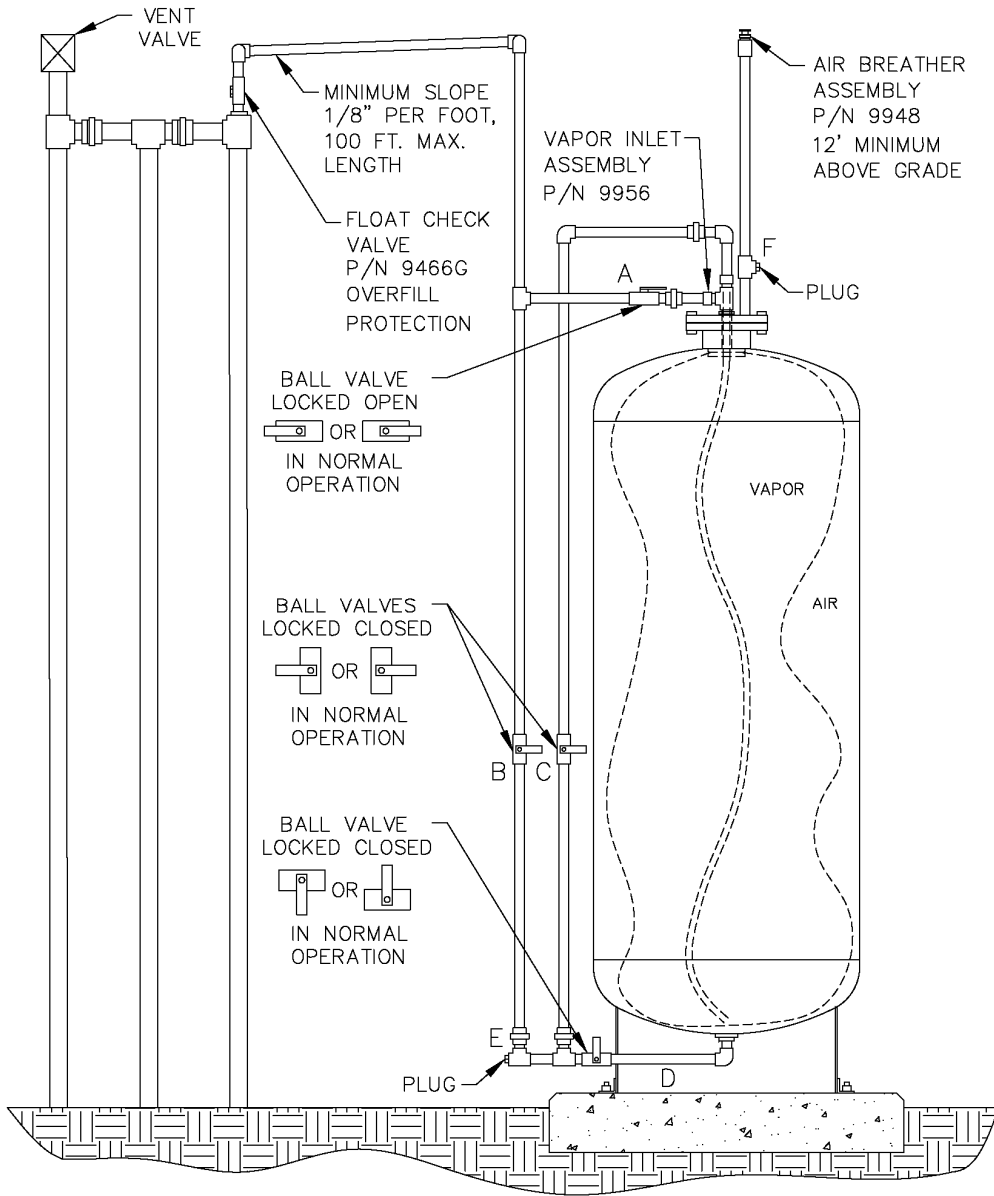

FIGURE 14-3H
Normal Clean Air Separator Operating Configuration

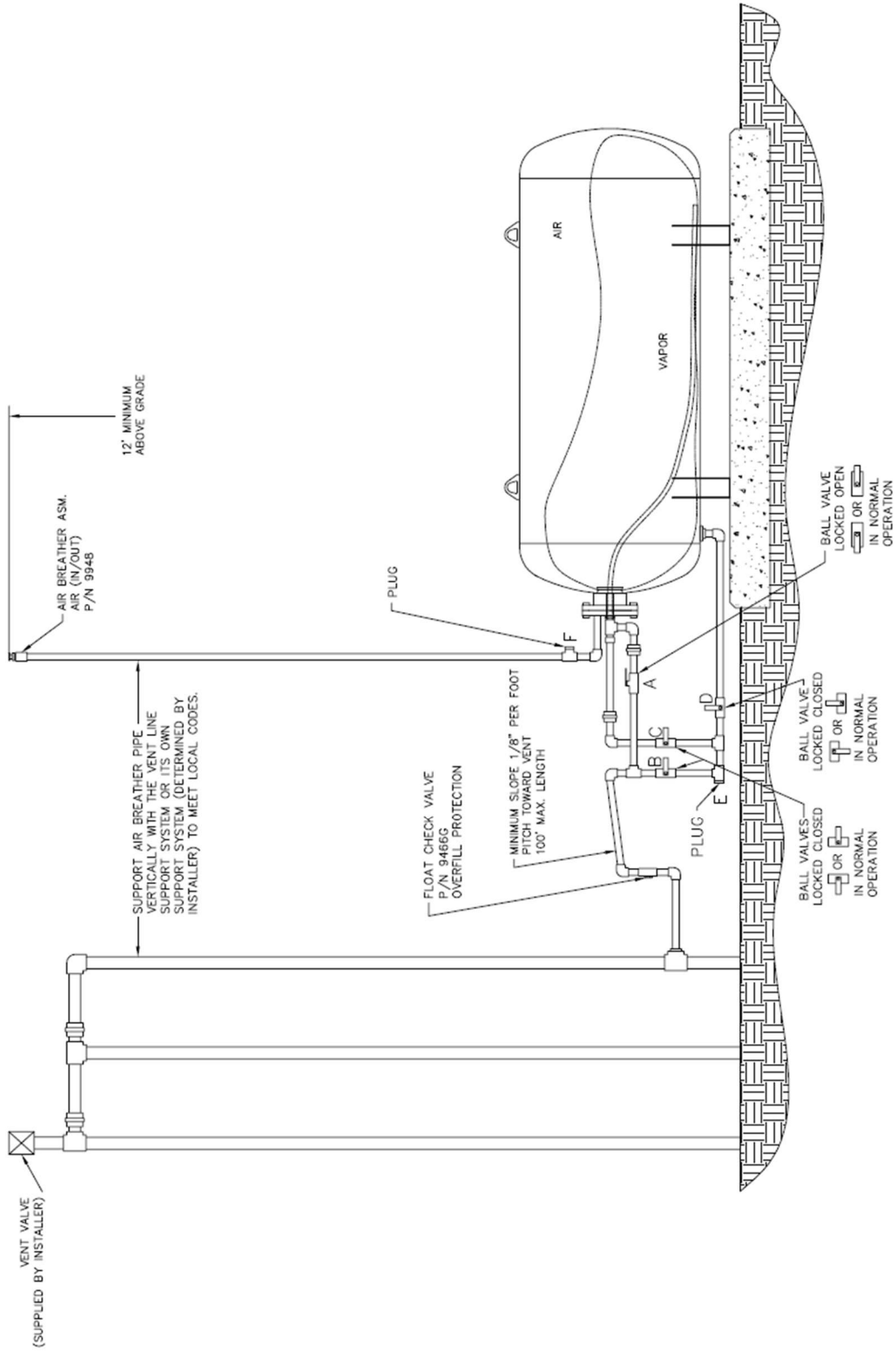

FIGURE 14-4

Clean Air Separator in Configuration to Conduct Test

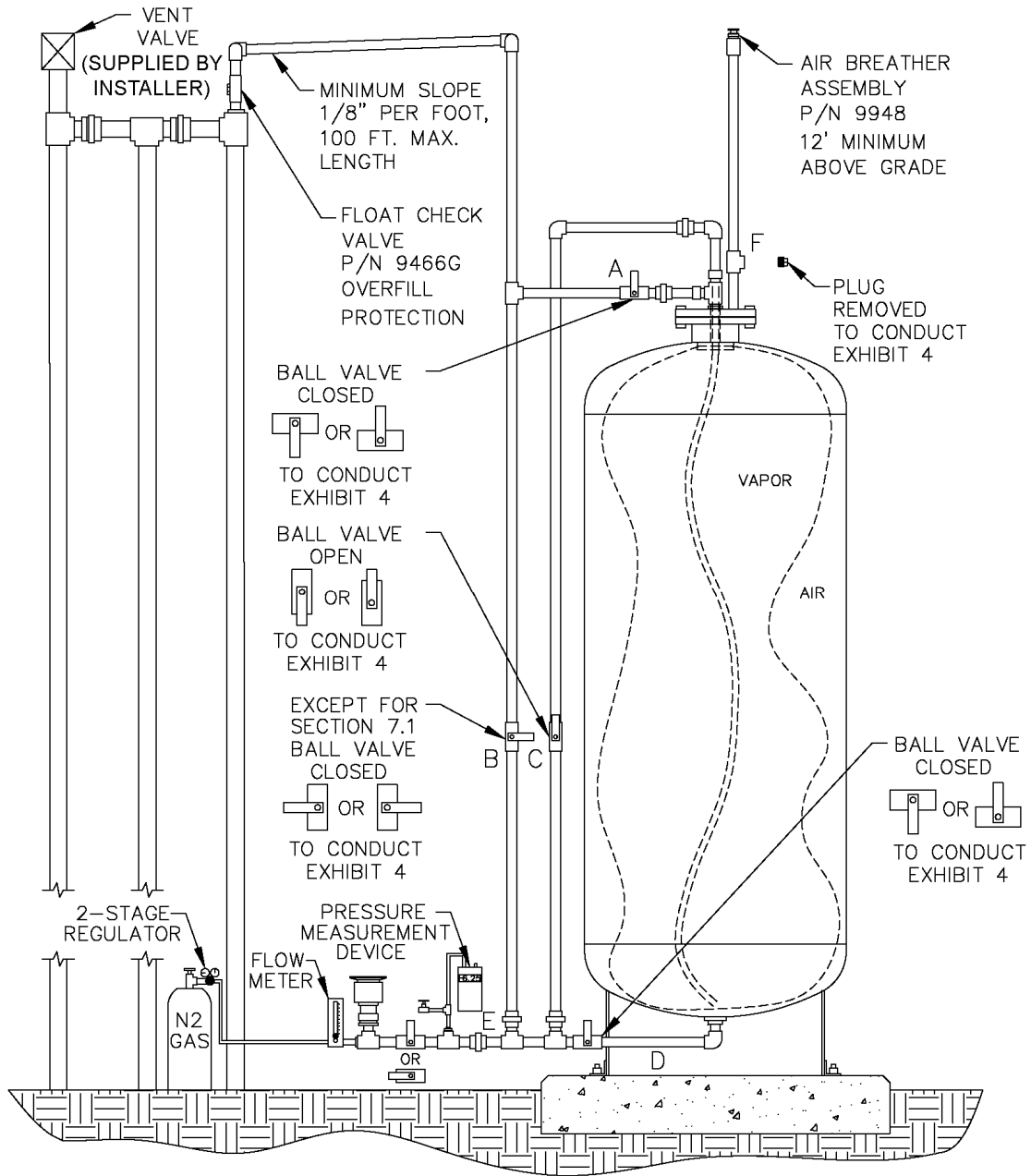
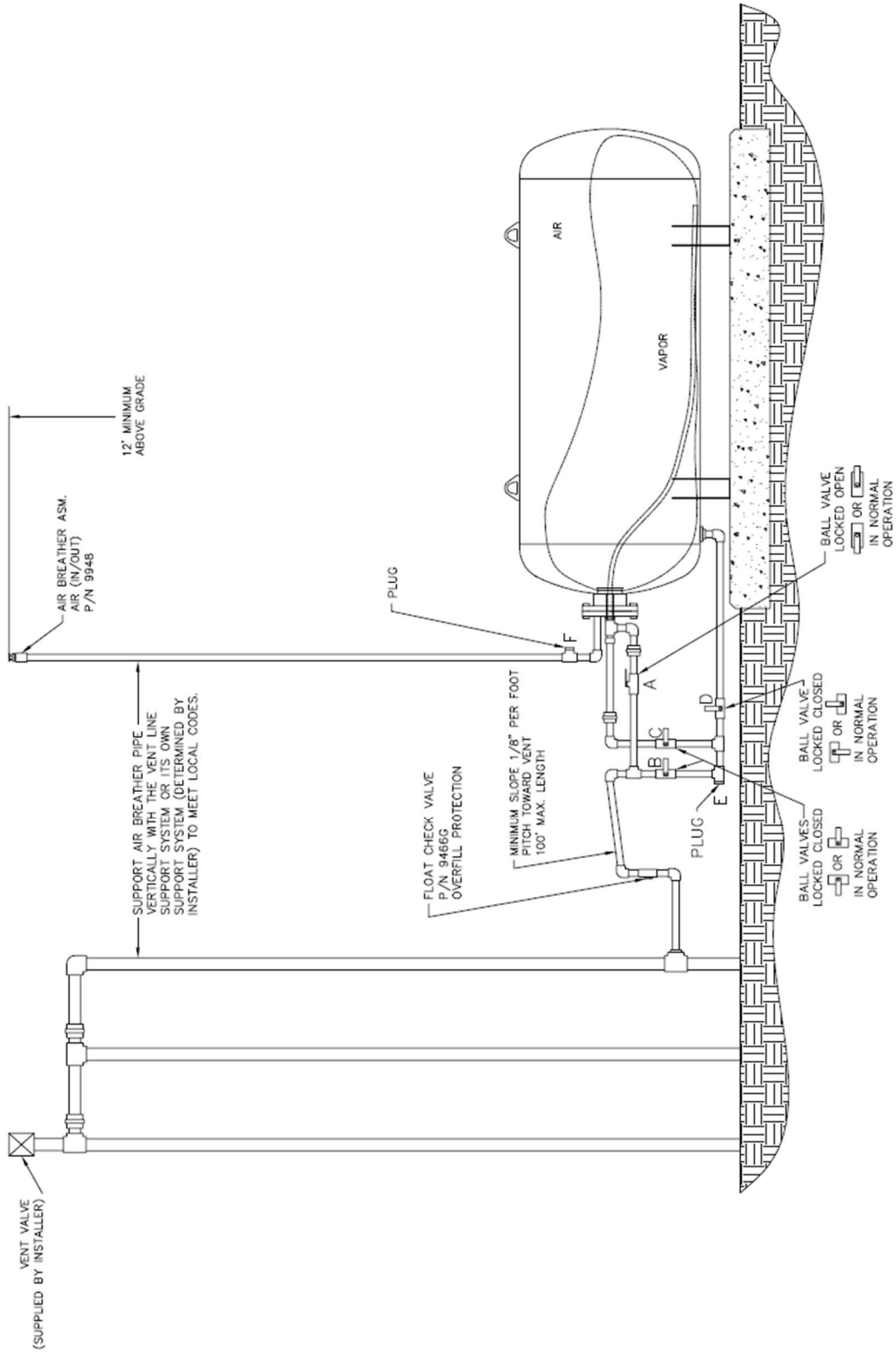

FIGURE 14-4H
Clean Air Separator in Configuration to Conduct Test



7. TEST PROCEDURE

- 7.1. Open the ball valve marked "B" from Figure 14-3 or Figure 14-3H. The pressure measurement device installed on the Test Port Assembly should now be reading UST and Clean Air Separator ullage pressure (or vacuum).
- 7.2. If the station vacuum is greater than (more negative) than -2.00" wc, then proceed to Section 7.2.1. If less than -2.00" wc, then proceed to Section 7.3:
 - 7.2.1 Close the ball valves marked "A" and "B" from Figure 14-3.
 - 7.2.2 Open the ball valve marked "C" from Figure 14-3 and wait one minute.
 - 7.2.3 If necessary, use the needle valve on the Test Port Assembly to bleed air into the bladder until the vacuum level reaches as close to a whole number on the pressure measurement device as the accuracy of the device will provide (ie. -2.00, -3.00, -4.00, -5.00, -6.00, -7.00, -8.00). Make sure the needle valve is closed. Record this vacuum and start the stop watch to begin a 5 minute decay.
 - 7.2.4 Record the vacuum at one-minute increments up to 5 minutes.
 - 7.2.5 Using the information from Table 14-1, verify that the vacuum after 5 minutes is equal to or greater than the allowable minimum for the initial vacuum recorded from Section 7.2.3.
 - 7.2.6 If the vacuum is greater than the allowable minimum, the Clean Air Separator passed the test.
 - 7.2.7 If the vacuum is less than the allowable minimum, the Clean Air Separator failed the test.

TABLE 14-1

Allowable 5 Minute Vacuum Decay for Clean Air Separator

Vacuum at Start of Test (inches wc)	Allowable Minimum Vacuum after 5 min. (inches wc)
8.0	5.5
7.0	4.7
6.0	3.8
5.0	3.0
4.0	2.2
3.0	1.5
2.0	0.8

- 7.3. If the station vacuum is less than -2.00" wc (from Section 7.2), or at the direction of district (refer to Section 2.2), conduct the following:
- 7.3.1 Close the ball valves marked "A" and "B" from Figure 14-3.
 - 7.3.2 Open the ball valve marked "C" from Figure 14-3.
 - 7.3.3 Open the ball valve of the Test Port Assembly and flow nitrogen into the Clean Air Separator bladder at a flow rate between 2 and 4 CFM until the pressure in the bladder reaches 2.20" wc.
 - 7.3.3.1. Depending upon the nitrogen flow rate used, the bladder could take up to 30 minutes to fill completely.
 - 7.3.3.2. Because of the close proximity of the pressure measurement device to the nitrogen inlet of the Test Port Assembly, the pressure measurement device may read a higher pressure when nitrogen is flowing. The pressure measurement device is usually steady, but will start to increase rapidly when the bladder is getting full. Periodically stopping nitrogen flow will provide an accurate reading of the pressure in the bladder.
 - 7.3.4 Once the pressure reaches 2.20" wc, shut off the flow of nitrogen to the Clean Air Separator bladder and close the ball valve of the Test Port Assembly.
 - 7.3.5 Wait 5 minutes or until pressure stabilizes above 2.00" wc. If the pressure does not stabilize, repeat steps 7.3.3 and 7.3.4.

- 7.3.6 Use the needle valve on the Test Port Assembly to bleed off the nitrogen until the pressure reaches 2.00" wc. Make sure the needle valve is closed. Record the pressure.
- 7.3.7 Start the stop watch to begin a 5 minute decay.
- 7.3.8 Record the pressure in one-minute increments up to 5 minutes.
- 7.3.9 If the pressure in the bladder is greater than 1.77" wc at the end of 5 minutes, then the Clean Air Separator passed the test.
- 7.3.10 If the pressure in the bladder is less than 1.77" wc at the end of 5 minutes, then the Clean Air Separator failed the test.
- 7.4. If the bladder was evaluated using the vacuum procedure (Section 7.2), close the ball valve "C" to keep it in a vacuum condition. If the bladder was evaluated using the pressure procedure (Section 7.3), open the needle valve on the Test Port Assembly to bleed off all pressure from the bladder.
- 7.5. Close the ball valve marked "C", if not already done.
- 7.6. Remove the Test Port Assembly from location "E" and install the 1" pipe plug. Use a pipe sealant approved for use with gasoline on the threads and tighten to 60 ft-lbs.
- 7.7. Install the 1" pipe plug to location "F". Use a pipe sealant approved for use with gasoline on the threads and tighten to 60 ft-lbs.
- 7.8. Open the ball valve marked "A". Lock all ball valves using the padlocks.
- 7.9. The Clean Air Separator should now be in normal operation configuration. Verify this by using the outline from Section 6.7 and Figure 14-2 or Figure 14-2H

8. REPORTING

Record test data on the form shown in Figure 14-4. Districts may require the use of an alternate form, provided that the alternate form includes the same minimum parameters as in Form 1.

Form 1

**Data Form for Determination of Static Pressure Performance of the
Healy Clean Air Separator for Executive Order VR-203 and VR-204**

SOURCE INFORMATION		
GDF Name and Address <hr/> <hr/> <hr/>	GDF Representative and Title <hr/> <hr/> GDF Phone No. <hr/>	
Date and Time of Last Fuel Drop to GDF: <hr/> Date of Last Calibration of Pressure Measurement Device: _____	P/O #: _____ A/C#: _____ District Test Witness: _____	
VACUUM TEST (Section 7.1 through 7.2.7)		
Vacuum at start of test, inches water column (7.2.3)	_____	_____
Vacuum at one minute, inches water column	_____	_____
Vacuum at two minutes, inches water column	_____	_____
Vacuum at three minutes, inches water column	_____	_____
Vacuum at four minutes, inches water column	_____	_____
Final vacuum at five minutes, inches water column	_____	_____
Allowable minimum vacuum, inches water column (from Table 1)	_____	_____
POSITIVE PRESSURE TEST (Section 7.3 through 7.3.9)		
Pressure at start of test, inches water column (7.3.6)	_____	_____
Pressure at one minute, inches water column	_____	_____
Pressure at two minutes, inches water column	_____	_____
Pressure at three minutes, inches water column	_____	_____
Pressure at four minutes, inches water column	_____	_____
Final pressure at five minutes, inches water column	_____	_____
Allowable final pressure, inches water column (7.3.9)	_____	1.77
Healy Certified Technician Name, Certification Number and Expiration Date	Test Company	Date Test Conducted