

Port of Richmond

Port Plan for Ocean-Going Vessels



Richmond, California
April 2022 (Original December 2021)



Alan Wolken and Robert Stevens
Contract Port Director/ Contract Port Engineer
1322 Canal Boulevard
Richmond, CA 94802

I am the Port of Richmond's Responsible Official. This terminal plan was prepared under my supervision.

Alan Wolken

Signature

04.19.2022

Date

Alan Wolken
Interim Contract Port Director
awolken@ci.richmond.ca.us
707.410.6299

Submitted to: shorepower@arb.ca.gov

CONTENTS

INTRODUCTION 1

POINT POTRERO MARINE TERMINAL 2

TERMINAL 2 4

TERMINAL 3 5

FIGURES

Figure 1 – Point Potrero Marine Terminal
Drawing E1– PPMT Shore Power Service

INTRODUCTION

The Port of Richmond is a department of the City of Richmond that operates dry bulk, liquid bulk, break-bulk, and automobile processing facilities on the City's southern waterfront. The Port's property includes the Point Potrero Marine Terminal (Shipyard Number 3) as well as Terminals 2, and 3.

The land use of Richmond's southern waterfront specifically along the Harbor Channel and Santa Fe Channel are regulated by the City of Richmond's General Plan and Zoning Code in association with Metropolitan Transportation Commission and the Bay Conservation and Development Commission (BCDC) the San Francisco Bay Area Seaport Plan as Amended January 2012. BCDC reserves these areas for Port Priority Use.

Areas with Port Priority Use have excellent access to deep navigable waters as in 1996 Congress authorized deepening of the Harbor and Santa Fe channels from (-)35 to (-)38 feet at Mean Lower Low Water allowing for large vessels to enter. In addition, the Port has strong connectivity to both Union Pacific and the Burlington Northern Santa Fe railroads as well as roadways and interstates.

As described in the Seaport Plan, the Port of Richmond includes both the public and private terminals as Port Priority Use. The public terminals include the Point Potrero Marine Terminal as well as Terminals 2 and 3. There are nine other privately owned facilities along the Santa Fe Channel.

As required by the California Code of Regulations, terminal operators such as the Port of Richmond are required to submit a terminal plan that discusses how the terminal will comply with the requirements for ocean-going vessels to reduce oxides of nitrogen (NOx), reactive organic gases (ROG), particulate matter (PM), diesel particulate matter (DPM), and greenhouse gas (GHG) emissions from ocean-going vessels while docked at berth.

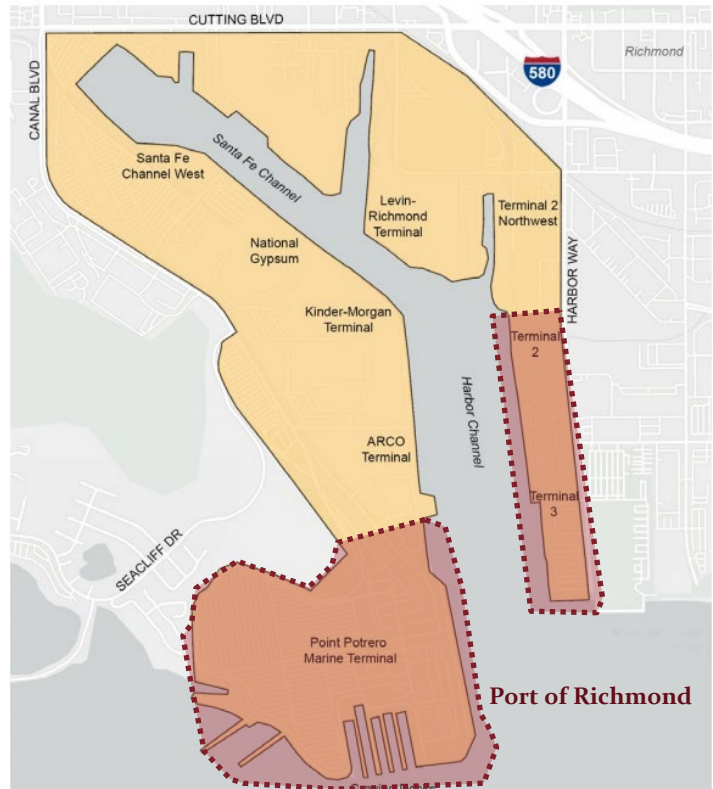

Figure 1. The Port of Richmond as described in the BCDC Sea Port Plan.

POINT POTRERO MARINE TERMINAL

Point Potrero Marine Terminal (PPMT) is the former Historic Shipyard Number 3 developed to construct Liberty and Victory Ships during World War II. The facility is located at the end of Canal Boulevard as shown in **Figure 1**. Its current configuration is similar to as constructed for the war effort as the graving basins, wharf, and several buildings still exist. PPMT has several tenants with the majority of the site occupied by Auto Warehousing Company (AWC).

AWC imports automobiles from Japan and China using the berth also known as piers 7 and 8 fronting the Harbor Channel. Based upon data from AWC, they received the following total number of ships over the last five years:

Year	Total Number of Vessels
2016	71
2017	88
2018	100
2019	92
2020	68

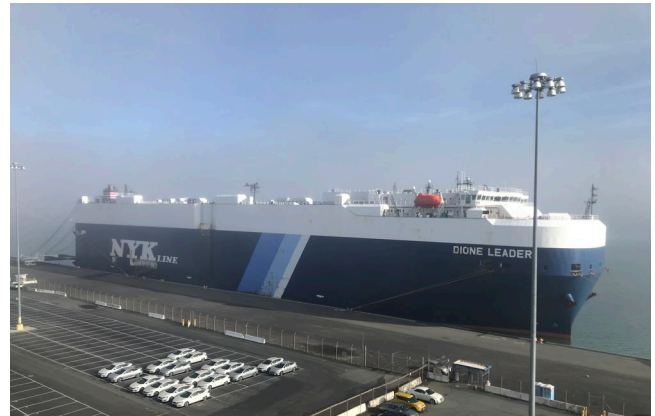

Typical vessel that calls on PPMT about 1 to 2 times each week. Pictured here is the Dionne Leader, which is almost 700 feet in length.

The geographic location of the berth is at 37°54'26.76"N and 122°21'50.65"W.

The remaining tenants of the PPMT are marine construction and towing and do not export or import cargo.

A vessel calling the AWC facility requires about 1,800 KW of electrical power at berth to maintain the ship’s operations. Thus, the Port plans to construct a shore power service as shown in **Drawing E1**. This will include conductors that plug into the vessel and connect to the Port’s electrical system. AWC will reimburse the Port for the electricity used consistent with its current tariff.

To fund the improvements, the Port applied to the Bay Area Air Quality Management District’s Volkswagen Environmental Mitigation Trust for funding of shore power at the terminal. The Port estimates the cost of this project will be about \$1.3 million.

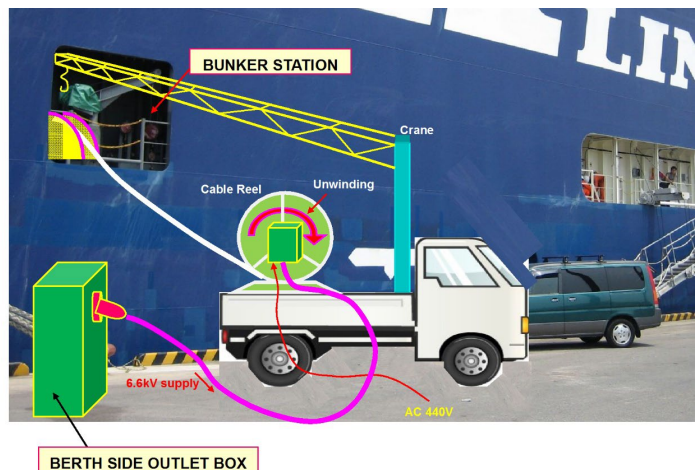

Proposed shore power connection at PPMT.

The Port is responsible for installing the electrical equipment. AWC will operate and maintain the electrical equipment installed by the Port at PPMT.

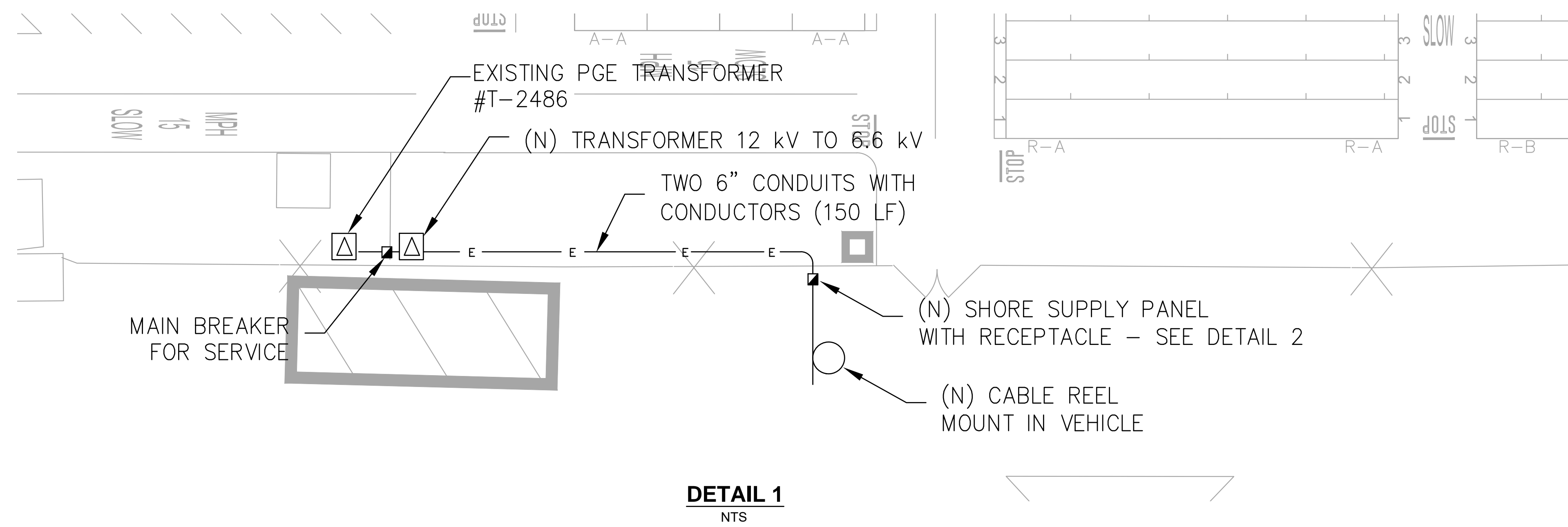
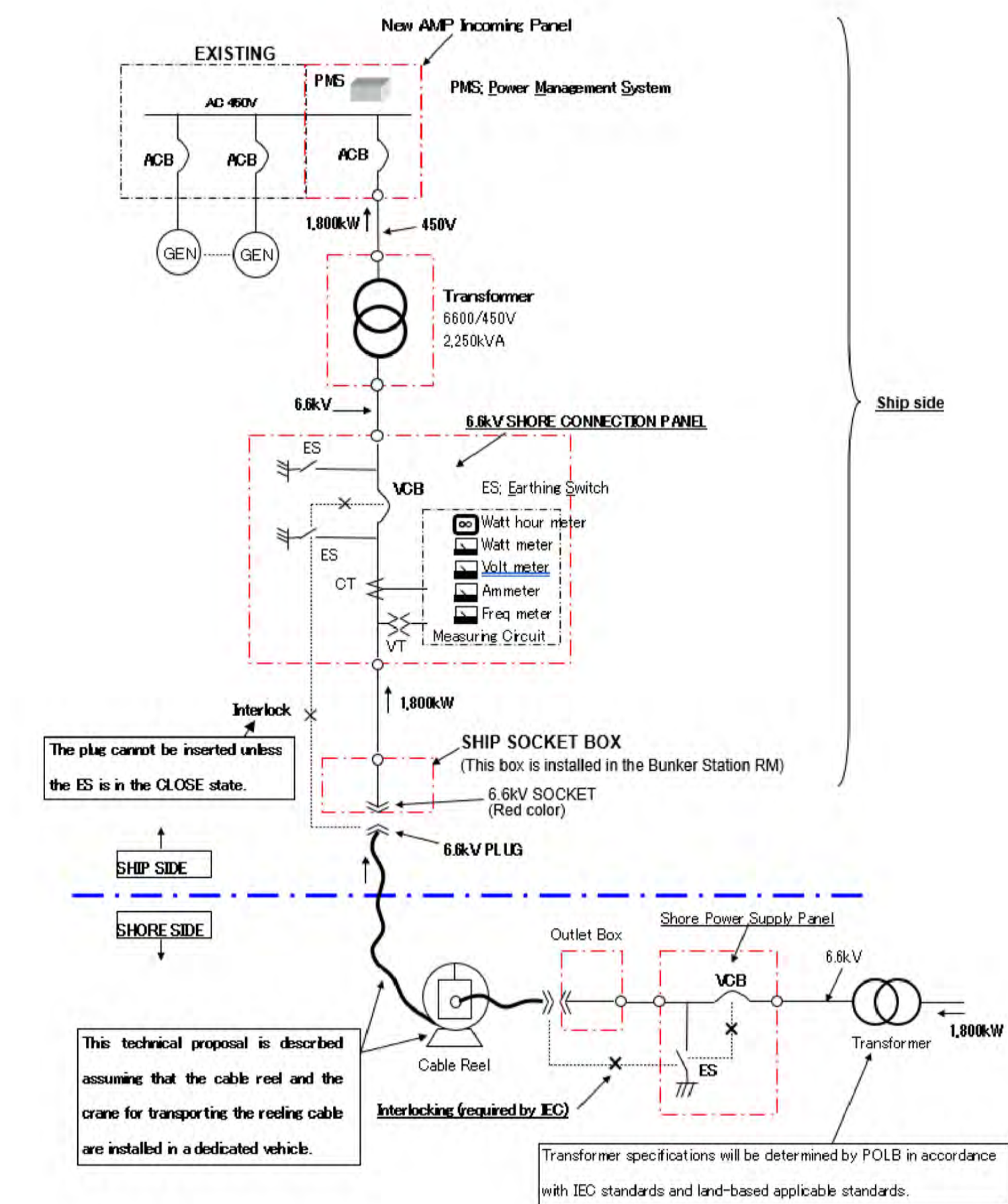
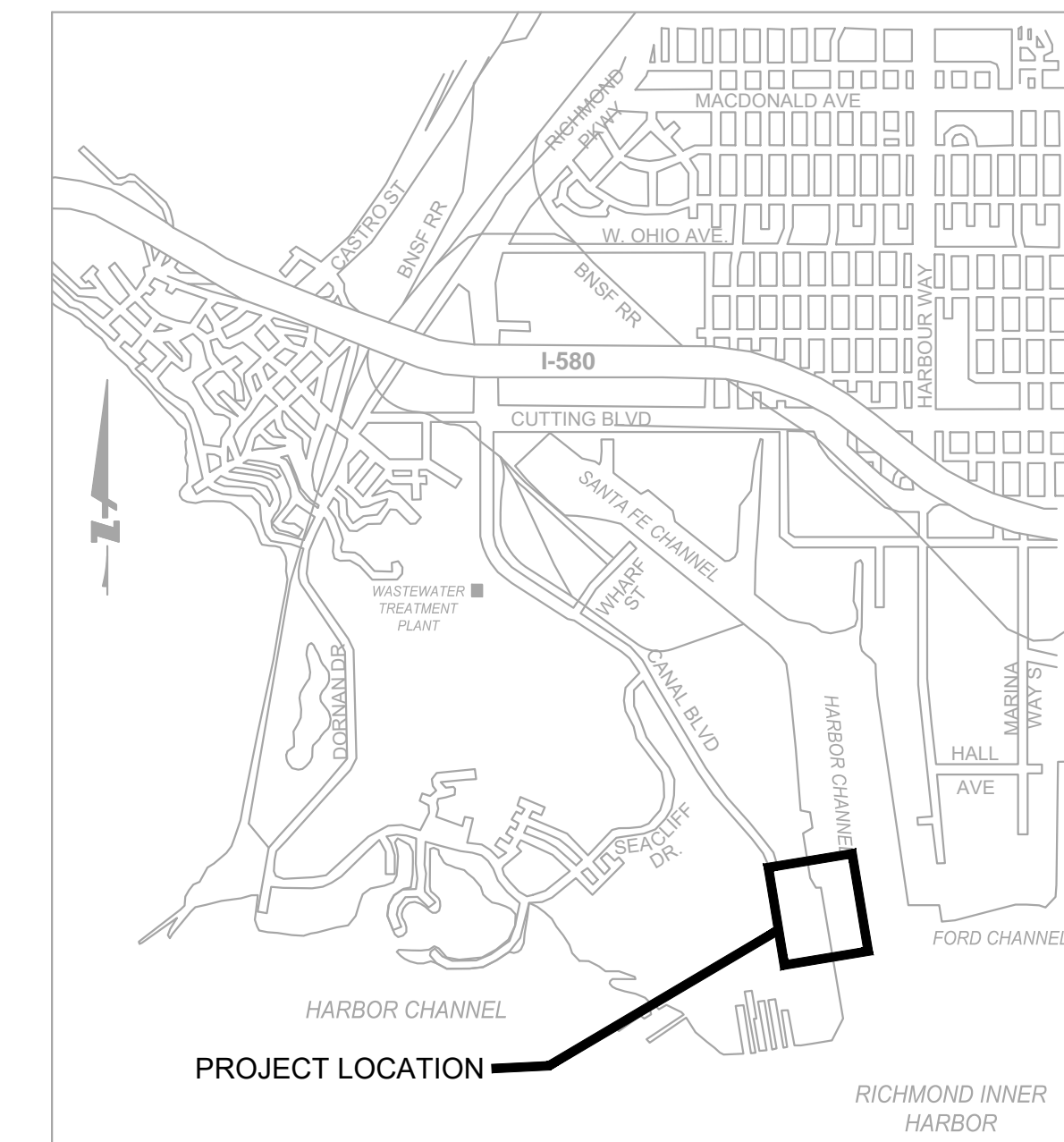
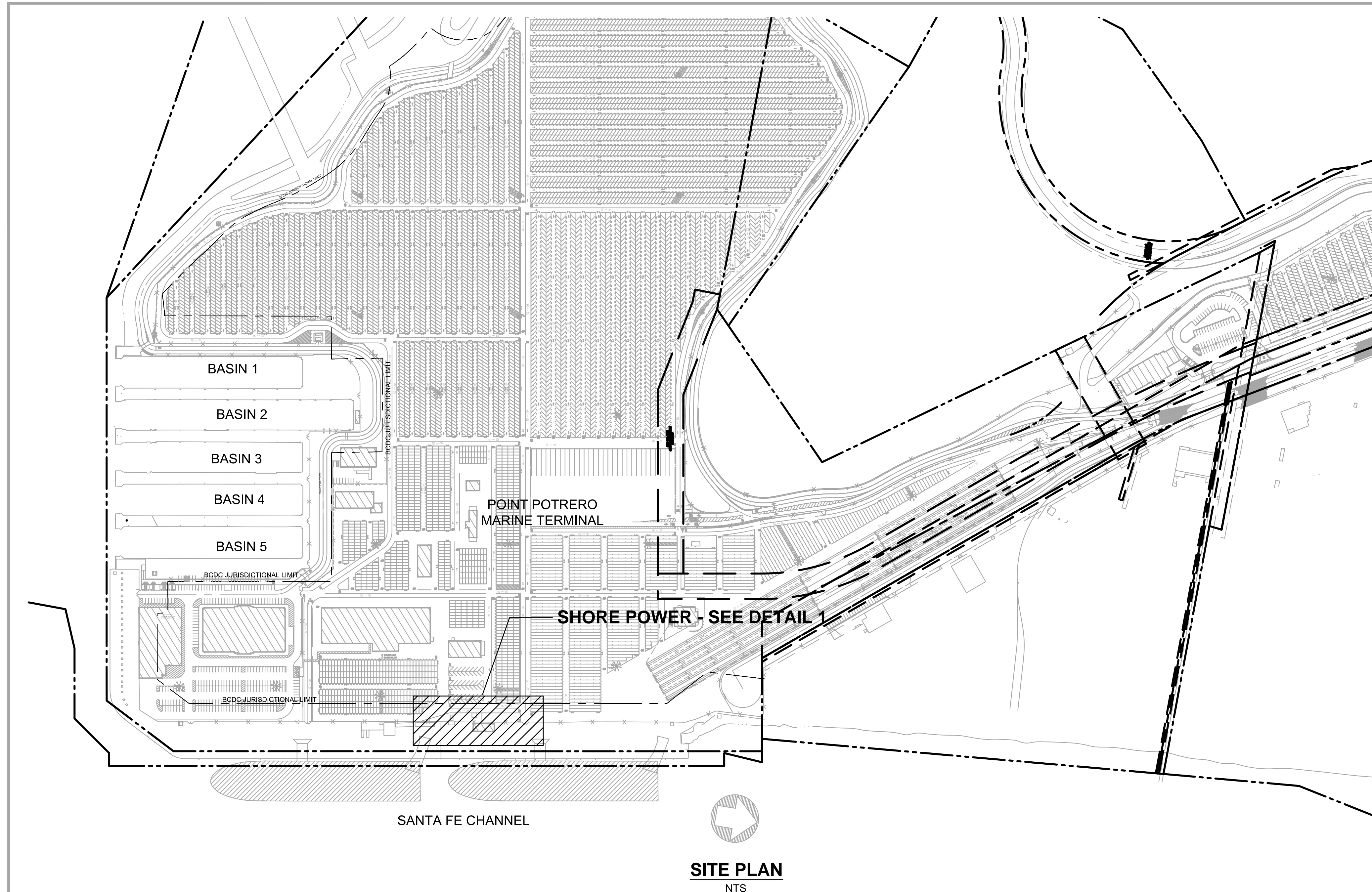

NO.	DESCRIPTION	BY	DATE	APP'VD

CSW | ST 2
 210 WASHINGTON AVENUE SUITE G
 RICHMOND, CA 94801

PORT OF RICHMOND
 POINT POTRERO MARINE TERMINAL
 SHORE POWER

DATE	07.15.21	SCALE	NONE
JOB NO.	NONE		
COUNTY NO.			
SHEET NO.			
FILE NO.	E-1		

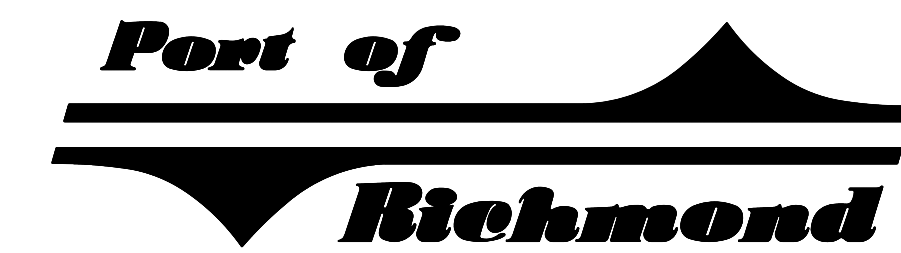

Once funding is identified, the Port anticipates implementing the project over a two year period that includes the following elements:

Item	Duration
Detailed Design	3 months
PG&E Coordination	9 months
Bidding and Council Approval	2 months
Procurement of Materials and Construction	4 months

TERMINAL 2

Terminal 2 is generally shown in **Figure 1** and is located to the north of Terminal 3 on the east side of the Harbor Channel. The geographic location is 37°54'56.90"N 122°21'42.65"W. The berth length is about 650 feet.

The Port has leased this terminal to AAK (formerly California Oils) since the 1990s. The key infrastructure is the berth that allows vessels to discharge liquid bulk cargo. In the case of AAK, this is vegetable oil, which occurs about once per month. I

In general, one vessel per month calls Terminal 2 and stays at berth for a period of about one day. The following is a summary of vessels arriving at the terminal over the last several years.

Year	Total Number of Vessels	Quantity Metric Tons
2018	12	84,437
2019	11	66,196
2020	12	80,220



Typical vegetable oil vessel (Azalea Galaxy) that calls Terminal 2.

While we are working with AAK to determine the electrical load required by their vessels, we believe it to be about 2,000 KW of electrical power at berth to maintain the ship’s operations. The Port plans to construct a shore power service similar to the system shown in **Drawing E1**. However, this system is more complex than PPMT as there is limited electrical infrastructure at the berth. The ultimate installation will include conductors that plug into the vessel and connect to the Port’s electrical system. The AAK will reimburse the Port for the electricity used consistent with its current tariff.

Once funding is identified, the Port anticipates implementing the project over a two year period that includes the following elements:

Item	Duration
Detailed Design	3 months
PG&E Coordination	9 months
Bidding and Council Approval	2 months
Procurement of Materials and Construction	4 months

The Port is responsible for installing the electrical equipment. AWC will operate and maintain the electrical equipment installed by the Port at Terminal 2.

TERMINAL 3

Terminal 3 is generally shown in **Figure 1** and is located along Harbour Way South on the east side of the Harbor Channel. The geographic location of the facility is 37°54'47.55"N 122°21'41.49"W.

The total area is approximately 15 acres. There is an existing concrete wharf that is 1,000 linear feet in length and generally serves lay berthing of vessels.

The existing terminal has the capacity for shore power at 480V/400A services. The Port has leased this facility to Terminal 3 Partners who is responsible for management of vessels at the site. Vessels typically dock at the facility for periods of up to two weeks.



The Port of Richmond's Terminal 3 looking toward the west.



Terminal 3 had 480V/400A shore power available for docked vessels.

Terminal 3 Partners is responsible for installing and operating the electrical equipment at Terminal 3.