

Hydrogen Infrastructure for Fuel Cell Electric Trucks (FCETs/FCEVs)

Presentation by
Chris Kretz

February 25, 2019



Getting Started – Fuel Cell Electric Trucks

- Engage the experts
 - **Fuel cell**
 - **(Fuel cell electric) Truck OEMs**
 - **Hydrogen fuel & infrastructure providers**
 - Non-profits/trucking organizations
 - Funding agencies
- Consider different scenarios
- Truck options: 1-3, 5-10 or more trucks

Getting Started – Hydrogen Supply

Temporary Fueling

- Days, weeks, or months
- Minimal site preparation
- Outdoor fueling
- Ideal for early days, start-up
 - ie. – 1-3 trucks
 - AC Transit



Scaling Hydrogen Supply

- Various Options
 - Liquid hydrogen
 - Making hydrogen
 - Reforming – natural gas, biogas
 - Electrolyzer
 - Tri-generation (H₂ & power)
 - Pipeline hydrogen



Orange County Transportation Authority Station (2019)

- Delivered liquid hydrogen (AP LHY)
- Air Products design & key equipment
 - Air Products proprietary dual-phase compressors
 - 6-10 min. fills
- 10 buses initially
 - Similar tank size to Class 8 trucks
 - Can scale to 30, 50, or more trucks; additive not multiplicative
- Two dispensers
- Planned on-stream Spring 2019



SmartFuel[®] Liquid Hydrogen Truck Fueling Infrastructure

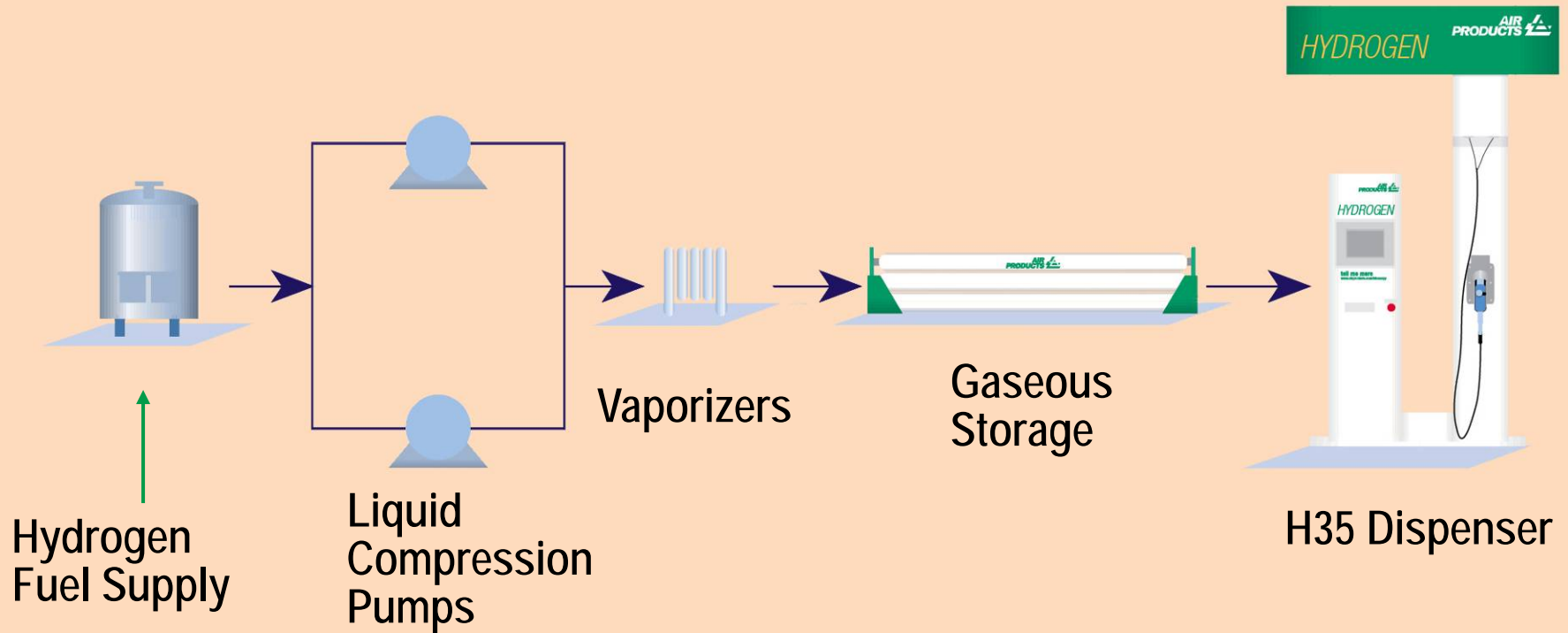

- Readily expandable to 30, 50 or more trucks
- Additive not multiplicative

Pipeline Hydrogen Station (25, 50, 100 Trucks or more)

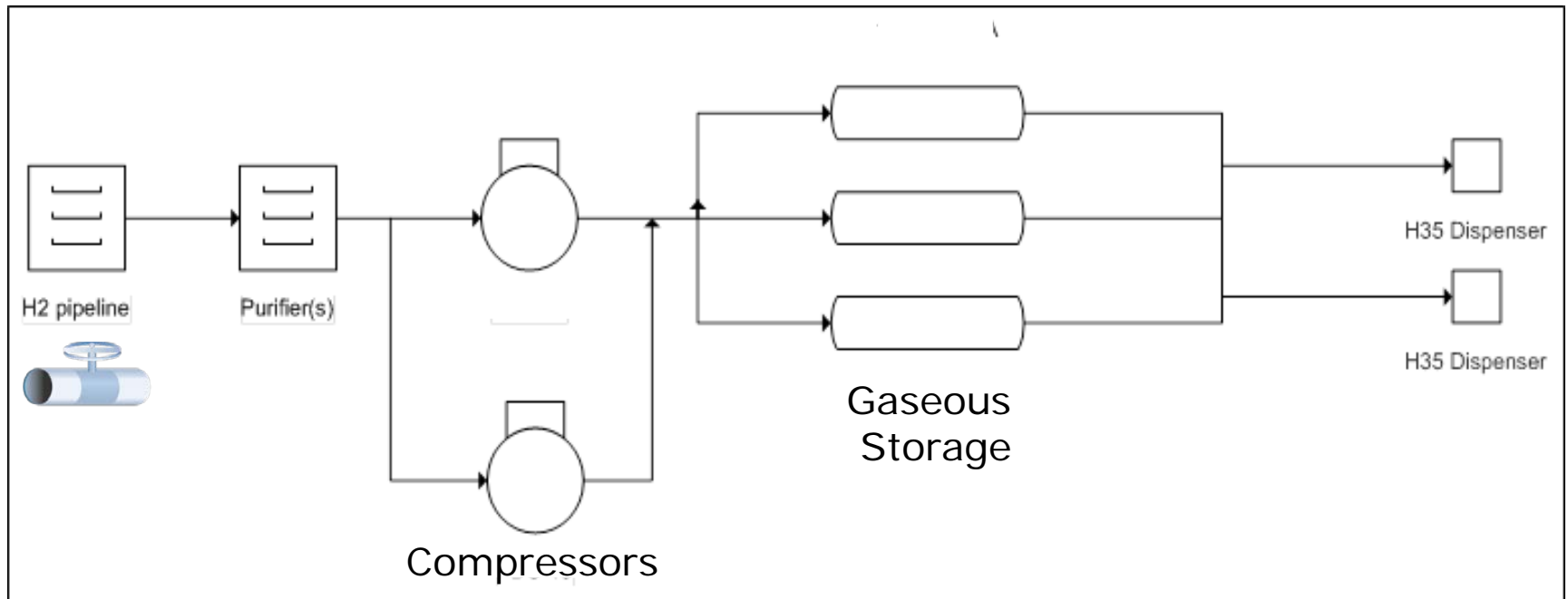

-Similar basic building blocks/pieces of equipment

Full Scale Deployment Option 2- On-Site Generation

- Air Products SmartFuel® H2 Generation Technology
 - 500kg/day (20 Class 8 trucks)
 - 1000kg/day (40 trucks)
 - 1600kg/day (60 trucks)
- One or more H₂ dispensers
- Installation in as little as 6-8 weeks
- More infrastructure & utilities needed
- Can be done via electrolysis as well

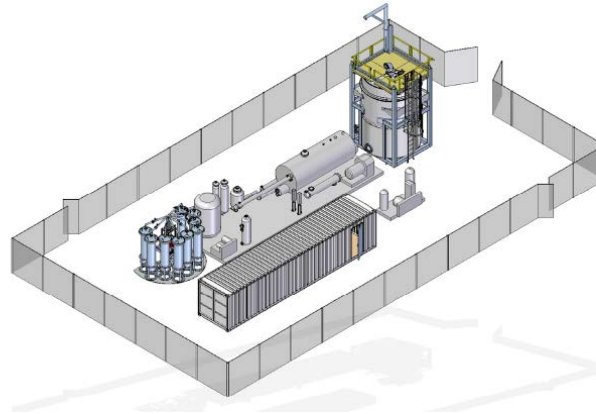

Hydrogen Supply Options and Key Framing Conditions

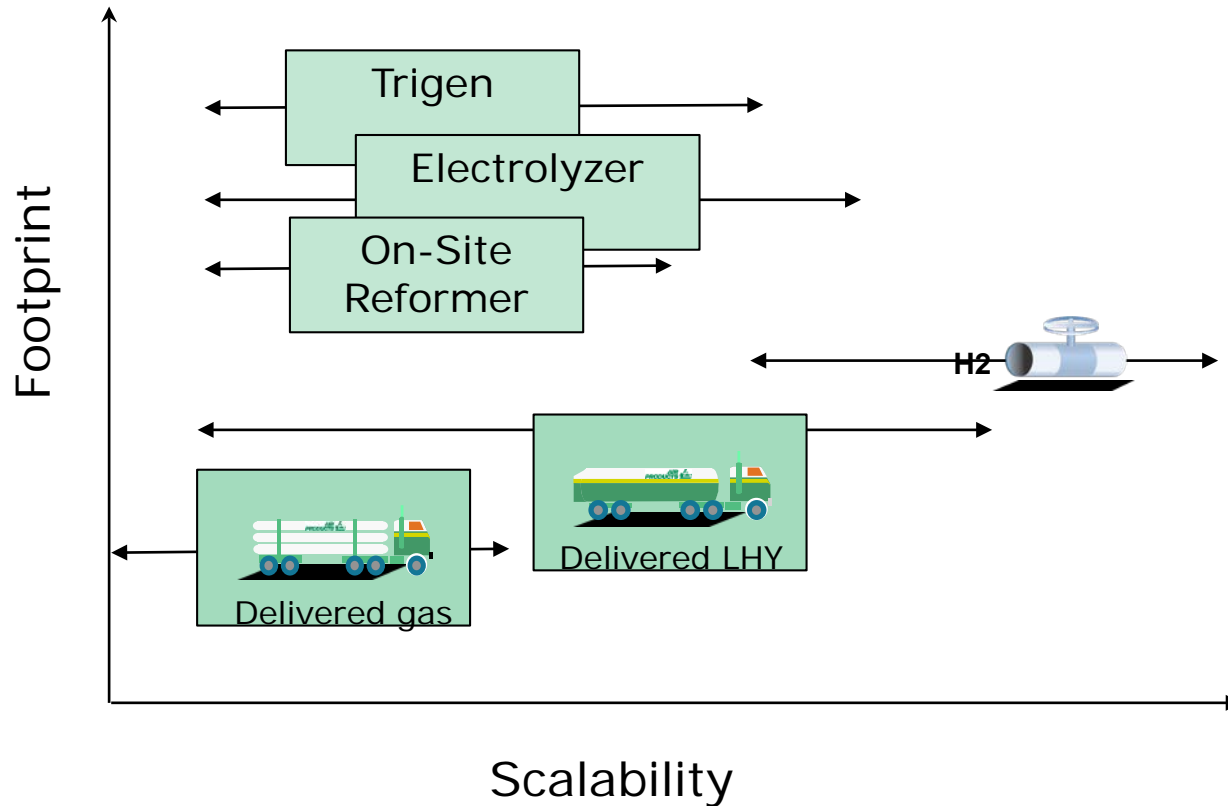

Thank you
tell me more

Chris Kretz
Business Development Manager
kretzcm@apci.com
610-481-5570



Full Scale Deployment Option 1- Liquid H2

- Liquid hydrogen delivery
- One or more H₂ dispensers
- Installation in as little as 6-8 weeks
- Good for 10-100 or more trucks
- Can lease, buy or do a mixed lease/buy

